

Owner's Manual for BMW Electric Ride On

BMW

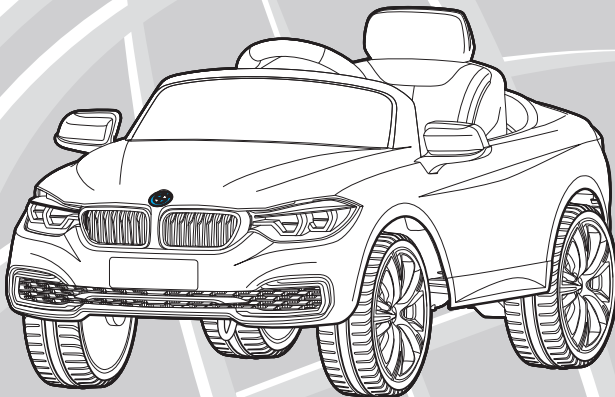

**This manual contains important safety, assembly, operation
and maintenance information.**

**Please read and fully understand this manual
before operation.**

Save this manual for future reference.

Date Code Label
Here



Owner's Manual Index

Safety

- Warnings.....3-4
- Vehicle Information 5

Assembly

- Parts Assembly View6-7
- Drive Motor and Wheel Installation..... 8
- Installing Steering Wheel, Power Supply and Seat 9
- Installing Windshield and Mirrors..... 10

Operation

- Operation and Features..... 11

Maintenance and Service

- General..... 12
- Drive Battery and Fuse..... 13
- Battery Re-charge Interval and Time..... 14
- Charging the Drive Battery 15
- Battery replacement and disposal 16
- Battery Storage..... 16
- Troubleshooting Guide17/18

Huffy Warranty

- Huffy Corporation Limited Warranty 19

WARNING

The user must follow all safety rules and guidelines below or serious injury or death may occur to the user.

- Always use common sense and safe practices when using the vehicle. This vehicle is unsuitable for children under 3 years. The user must be 3 to 5 years, and weigh no more than 65 lbs (30kgs).
- This product contains small parts that are for adult assembly only. Keep small children away when assembling. Remove and dispose of all protective material and poly bags before assembly. Be sure to remove all packaging materials and parts from underneath the vehicle body.
- Always use the vehicle in a safe, secure environment with continuous adult supervision.
- Body parts such as hands, legs, hair and clothing can get caught in moving parts. Never place a body part near a moving part or wear loose clothing while using the vehicle. Always wear shoes when using vehicle.
- Use on flat, smooth paved surfaces only.
- Using the vehicle on or near streets, motor vehicle, drop-offs such as: steps, water (swimming pools), sloped surfaces, hills, wet areas, flammable vapors, in alleys, at night or in the dark could result in an accident.
- Do not use the vehicle in unsafe conditions such as snow, rain, loose dirt, mud sand or fine gravel. This may result in unexpected action such as tip over and skidding.
- This vehicle has no brakes. Motor friction will gradually stop the unit.
- Do not use the vehicle in an unsafe manner. Examples include but are not limited to:
 - Pulling the vehicle with another vehicle or similar device.
 - Allowing more than one rider.
 - Pushing the vehicle.
 - Traveling at an unsafe speed.
- There are additional hazards of using the vehicle in areas other than private grounds.
- Not to be used in traffic.
- The vehicle shall be used with caution since skill is required to avoid falls or collisions.
- Do not overload the vehicle.
- Do not tow anything behind the vehicle.
- Do not drive up steep slopes.
- Do not drive into fixed objects, which may cause the wheels to spin, causing the motor to overheat.
- Do not drive in very hot weather, components may overheat.
- Do not allow water or other liquids to come in contact with the battery or other electric components.
- Do not tamper with the electrical system. Doing so may create a short, causing the fuse to trip or other damage including fire.
- Child should always wear an approved helmet when using this product.

WARNING - Charging the Drive Motor Battery

The following safety hazards may result in serious injury or death to the user of the vehicle:



- Use of a battery or charger other than the supplied rechargeable battery and charger may cause a fire or explosion. Only use the supplied rechargeable battery (or suitable replacement) and charger with the vehicle.



- Using the rechargeable battery and charger for any other product may result in overheating, fire or explosion. Never use the rechargeable battery and charger with another product.
- Explosion. Gases are created during charging. Charge the battery in a well ventilated area. Do not charge the battery near heat or flammable materials.



- Contact between the positive and negative terminals may result in fire or explosion. Avoid direct contact between the terminals. Picking up the battery by the wires or charger can cause damage to the battery and may result in a fire. Always pick up the battery by its case or handles.



- Battery must be handled by adults only. Liquids on the battery may cause fire or electric shock. Always keep all liquids away from the battery and keep the battery dry.
- Contact or exposure to battery leakage (lead acid) may cause serious injury. If contact or exposure occurs immediately call your physician. If the chemical is on the skin or in the eyes, flush with cool water for 15 minutes. If the chemical was swallowed, immediately give the person water or milk. Do not give water or milk if the patient is vomiting or has a decreased level of alertness. Do not induce vomiting.
- Battery Posts, terminals and related accessories contain lead and lead compounds (acid), chemicals known to cause cancer, reproductive harm and are toxic and corrosive. Never open the battery.
- Tampering or modifying the electric circuit system may cause a shock, fire or explosion and permanently damage the system. Exposed wiring and circuitry in the charger may cause electric shock. Always keep the charger housing closed.

Important! Before using the unit for the first time the battery needs to be charged for 10 to 12 hours, Only an adult who has read and understands the safety warnings should handle, charge or recharge of the battery (see Maintenance).

NOTE: It is not necessary to remove the battery from the vehicle for charging. However, if the adapter cord will not safely reach a 110-120 volt wall outlet, the battery can be removed for charging.

Vehicle Information

Applicable age	3-5 years old
Weight limit	65 lbs (30kg)
Power supply	Chargeable type (supplied)
Battery specifications	DC 6V/7AH
Charging source	Input: AC 100V-240V 50Hz/60Hz Output: DC 8V/750mA
Battery charging time	Charging time: 9-10 hours

Tools Needed for Assembly:

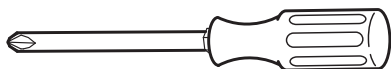

Phillips Screwdriver



Wrench Set

Radio Frequency Information

Caution: Changes or modifications not expressly approved by the party responsible for compliance could void the user's authority to operate the equipment.

NOTE: This equipment has been tested and found to comply with the limits for the Class B digital device, pursuant to Part 15 of the FCC Rules. These limits are designed to provide reasonable protection against harmful interference in a residential installation. This equipment generates uses and can radiate radio frequency energy and, if not installed and used in accordance with the instructions, may cause harmful interference to radio communications. However, there is no guarantee that interference will not occur in a particular installation. If this equipment does cause harmful interference to radio or television reception, which can be determined by turning the equipment off and on, the user is encouraged to try to correct the interference by one or more of the following measures:

- Reorient or relocate the receiving antenna.
- Increase the separation between the equipment and receiver.
- Connect the equipment into an outlet on a circuit different from that to which the receiver is connected.
- Consult the dealer or an experienced radio/TV technician for help.

User Requirements

The suitable age range for a child using the vehicle is 3 to 5 years. The maximum weight of the child is 65 lbs (30 kg).

Before using the vehicle the child must understand the controls and safety issues.

They must also demonstrate the capability to handle the vehicle and operate its controls.







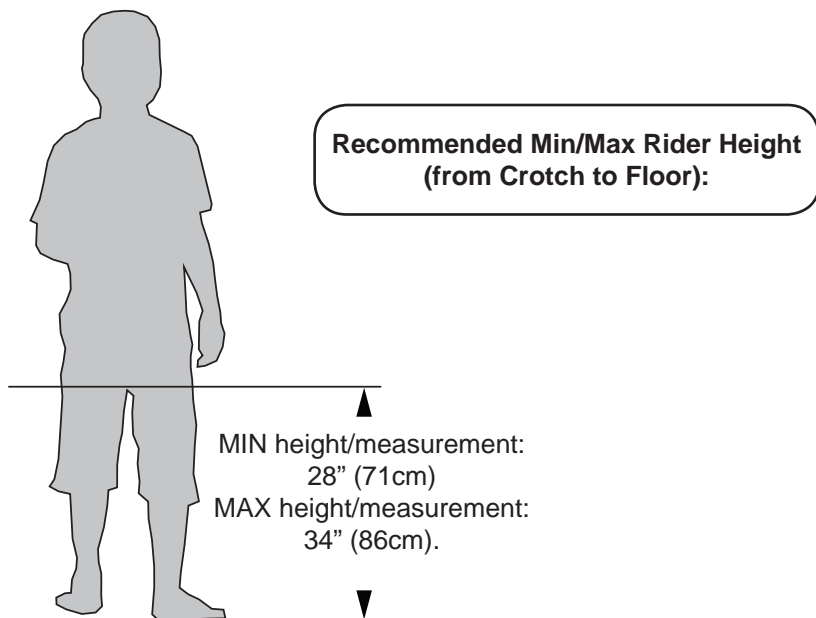



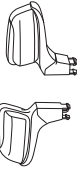



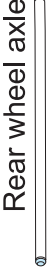
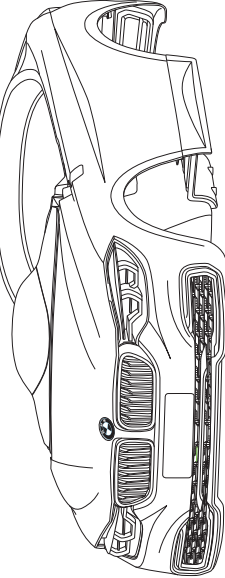

It is the responsibility of the adult to educate the child, determine if they are fit to operate the vehicle, and supervise use.

Here are basic safe riding rules you should read aloud to your child and anyone who may use the vehicle:

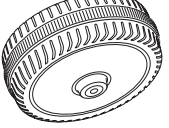
- An adult must always supervise a child that is using the vehicle.
- Always sit in the seat when using the vehicle.
- Keep your hands, hair and clothes away from moving parts. Always wear shoes when using in the vehicle.
- Do not use the vehicle on streets or near cars.
- Children under three years old should not be allowed use the vehicle.
- Only drive on level ground. Don't go near water, drop-offs or up and down steep slopes.
- Don't drive the vehicle in loose dirt, mud, sand or fine gravel. Using the vehicle in loose dirt, mud, sand, or fine gravel may damage the electronics and gear box inside the vehicle.

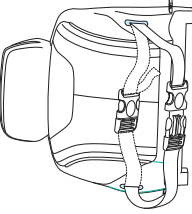

Parts List

 3. Steering wheel	 4. Rearview mirrors	 17 Washer x4
 2. Windshield	 7. Wheel cover x4	 18 Rear wheel axle
 1. Car body	 12 Front-wheel frame connecting -rod Nut x 2	 19 Rear wheel Spacer
 6. Driving wheel (with rubber wheel tread)	 13 J-shaped stick	 20 Buckle spring x4
 5. Car wheel x3	 14 Steering wheel screw	 21 Dash board accessory
 8. Backrest	 15 Steering Wheel Nut	 22 Charger
 9. Seat	 16 Seat & Backrest screw x4	

Installing the Drive Motor and Wheels

Installation of the front-wheel frame connecting-rod and wheel

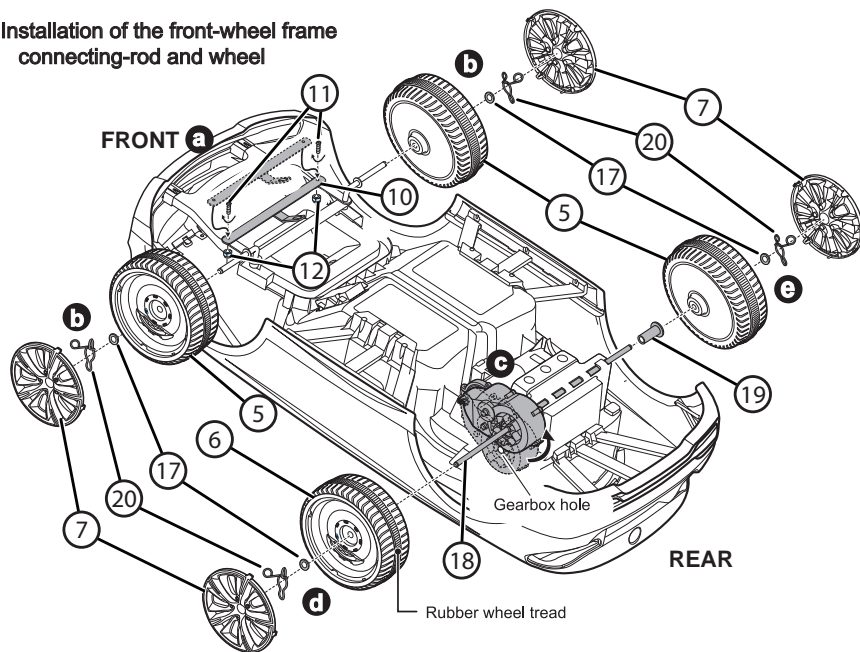

- a** • Install the front-wheel frame connecting-rod (10) as shown (may be pre-installed), and install screw (11) and locknut (12). Tighten securely, then loosen just enough so you can turn screw/nut by hand. **Screw threads must still be fully engaged into locknut.**
- b** • Insert the car wheel (5), washer (7) into the front wheel axle as shown. Insert the buckle spring (20) into the slot of wheel axle and snap wheel cover (7) in place. Repeat for opposite side.
- c** • Rotate the motor gearbox upward along with the direction of arrow, until the motor gearbox is aimed at car body axle hole.
- d** • Insert the rear wheel axle (18) as shown. Insert driving wheel (part 6, with rubber wheel tread) and washer (17) into the rear wheel axle as shown. Insert the buckle spring (20) into the slot of wheel axle and snap wheel cover (7) in place.
- e** • Insert the rear wheel spacer (19), wheel (5), washer (17) onto the front wheel axle as shown. Insert the buckle spring (20) into the slot of wheel axle and snap wheel cover (7) in place.

Installation of J - Steering Rod

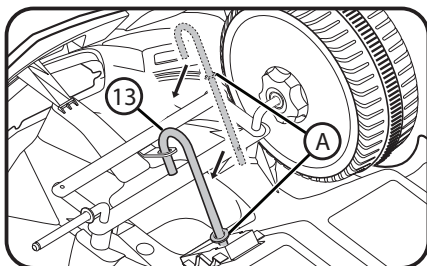

With the vehicle upside down, insert the long end of the J-shaped Steering Rod (13) into the body opening so that short end fits into the axle slot as shown and the fixed washer (A) sits against the car body.

Installing Steering Wheel, Power Supply and Seat

Installation of steering wheel:

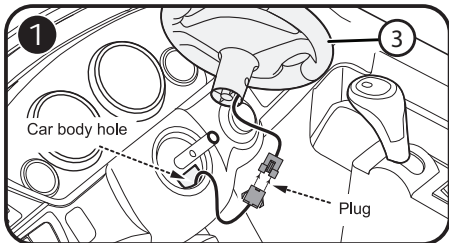

- Connect the steering wheel wire plug to the plug extending out of the car body hole.
- Put the connected plugs and wires down into the car body hole.

NOTE: Ensure wires are not pinched or bound up.

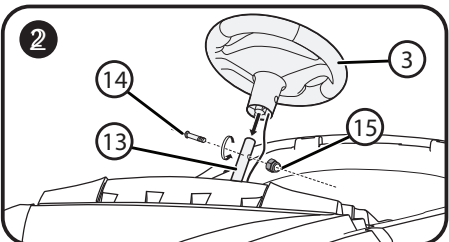

- With J-shaped Steering Rod held (13) in place, put the steering wheel (3) onto the Steering Rod end, and install the steering wheel screw (14) and nut (15)

Installation of power supply, seat and backrest:

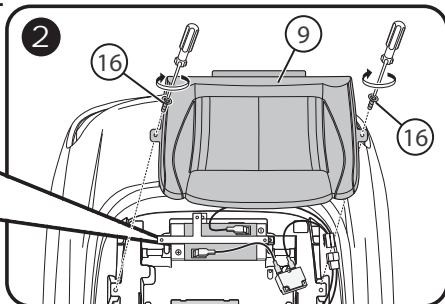
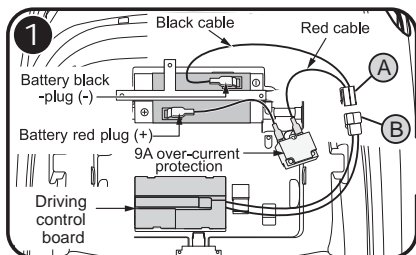

- When battery is installed or replaced, insert the Red cable terminal into the Red battery positive pole and the Black terminal into the Black battery negative pole.
- Connect Plug (A) to Connector (B) firmly.

After the power supply is installed, put the seat (9) into place as shown, and install seat screws (16).

⚠ WARNING: Connecting incorrectly will cause a short circuit.

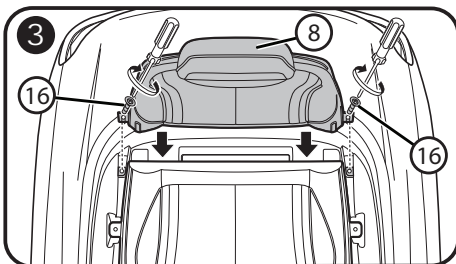

Insert the backrest (8) into place as shown and install the backrest screws (16) securely.

Installing Windshield and Mirrors

Installation of windshield and rearview mirrors

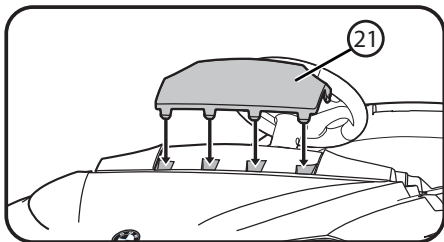

Insert the dashboard accessory (21) into the tab holes until they 'snap' securely.

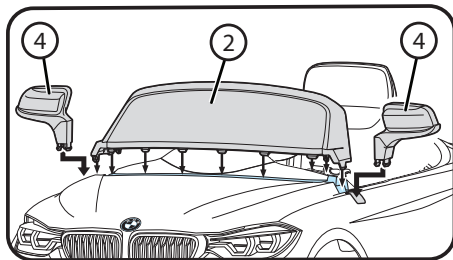

Install the windshield (2) and rearview mirrors (4) by inserting the tabs into the vehicle slots as shown. Press tabs in until a "snap" is heard.

Completed Assembly

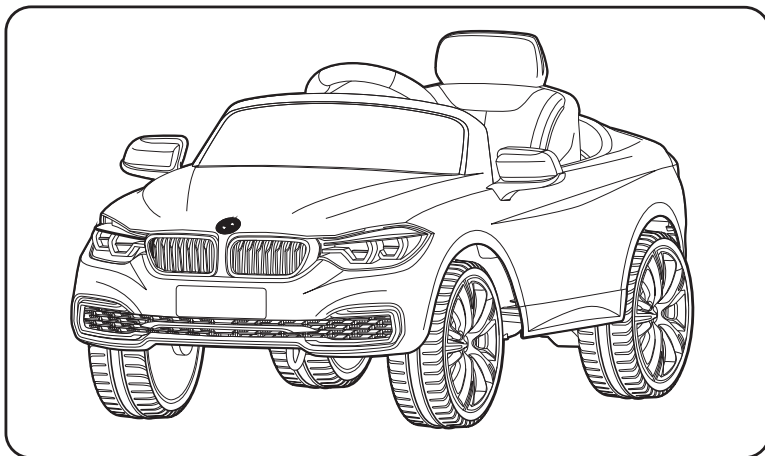

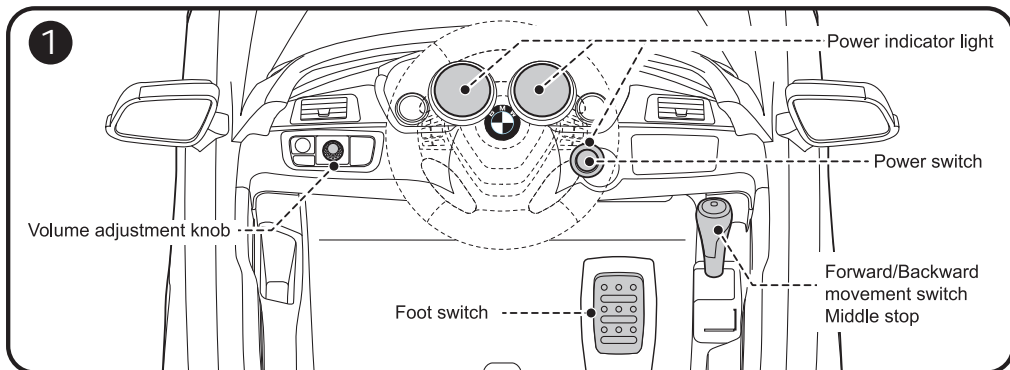

To Operate the vehicle:

1. **Power Button:** Push IN to turn on. Push in again to turn OFF. Leave OFF when not in use.
2. **Steering wheel:** Use to steer the vehicle in the direction you want to move.
3. **Sound Effects:** Press the Horn button on the steering wheel to play the Horn sound. Press the other buttons for additional sounds.
4. **Shift Lever:** Changes the direction the vehicle moves from forward to reverse.
 - To move the car forward, move the lever forward.
 - To move the car backward, move the lever backward.
 - Shift the lever in the middle, the car will stop and not run.

CAUTION: To avoid damaging the motors and gears, DO NOT shift the lever when the car is moving.

5. **Foot pedal:** Applies power (speed) to the vehicle.
 - To move the car, press the pedal down.
 - To brake or slow down, release pressure from the pedal.

⚠ WARNING: Use on level ground ONLY - This Unit Has NO Brakes. Motor friction will gradually stop the unit. **Vehicle may roll down a steep incline, even when turned off.**

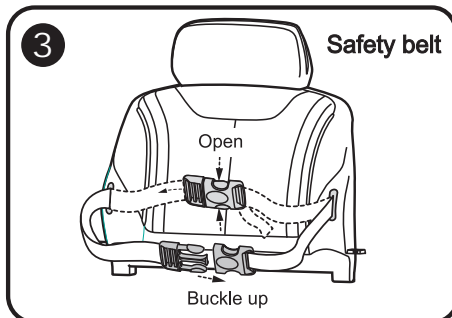
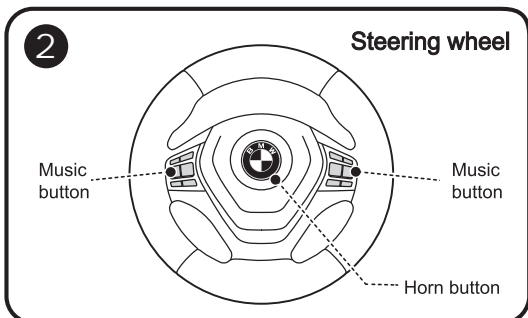

Maintenance

The vehicle should be checked for damage, missing or badly worn parts before each use.

- Check the tightness of the fasteners before each use.
- Check the tightness of the wheels:
 - **Note:** If the drive wheel is not tight, it will not engage the gears and the vehicle will not run.
 - Use a flat head screwdriver to remove the hubcaps.
 - Ensure the axle is fully engaged in the lock nut.
 - Replace the hubcaps.
- Ensure the battery bracket is securely in place before use.
- Store the vehicle indoors. Keep it away from sources of heat, such as stoves and heaters.
- Clean the vehicle with a soft, dry cloth. To restore shine to plastic parts, use a non-wax furniture polish. Do not use automotive wax, abrasive cleaners or wash the vehicle with soap and water.

 **WARNING:** Water will damage the motor, electrical system and battery.

Drive Battery

Only an adult who has read and understands the safety warnings should handle, charge or recharge the battery. Failure to comply with all safety warnings may result in serious injury or death.

Battery Fuse

The drive motor circuit features a thermal fuse that will automatically trip and cut all power to the vehicle if the motor, electric system or battery is overloaded. The fuse will reset and power will be restored after waiting for approximately five minutes. If the thermal fuse trips repeatedly during normal use, the vehicle may need repair.

DO NOT BYPASS THE FUSE - RISK OF FIRE. This may overload and damage the electrical system.

Battery Fuse is located under the seat.

To avoid losing power, follow these guidelines:

- Do not overload the vehicle.
- Do not tow anything behind the vehicle.
- Do not drive up steep slopes.
- Do not drive into fixed objects, which may cause the wheels to spin, causing the motor to overheat.
- Do not drive in very hot weather, components may overheat.
- Do not allow water or other liquids to come in contact with the battery or other electric components.
- Do not tamper with the electrical system. Doing so may create a short, causing the fuse to trip.

Re-charge Interval and Time

Important!

Check the drive battery and charger (supply cord, connector) for wear and damage before charging. Do not charge the battery if damage has occurred. Only replace with the same type 6V rechargeable battery and charger supplied by the manufacturer.

- Only use the rechargeable battery (or equivalent replacement) and charger supplied with your vehicle.
- Before first use, charge battery 10 to 12 hours - never longer than 15 hours.
- Once battery is depleted, recharge for 9 to 10 hours - never longer than 15 hours.
- Do not short circuit the battery: Do NOT connect red and black wires together or connect positive and negative terminals on the battery together.
- When battery is fully charged, un-plug charger from the wall outlet and disconnect from charger port.

The drive battery should be charged when depleted, or if not used regularly, once a month. Failure to charge the battery as directed will cause permanent damage to the battery and will void the warranty.

Charging the Drive Battery

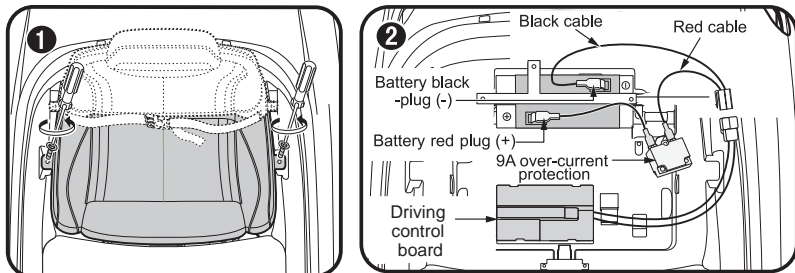

⚠ WARNING: Risk of fire.
Do not bypass or tamper.

Charging Port

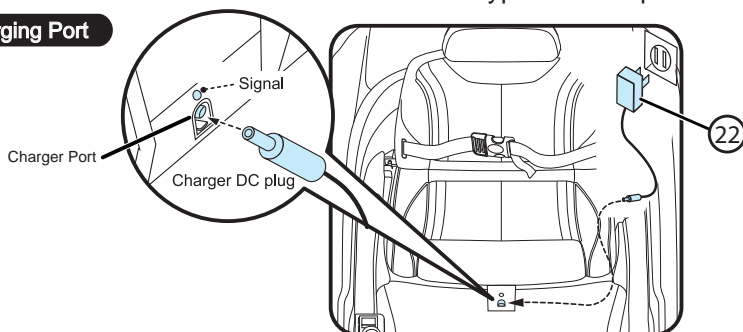

NOTE: Before first use, charge battery 10 to 12 hours.

1. Charge Drive Battery after 1-2 hours of use or when the vehicle does not move at its normal speed.
2. **Ensure Power Switch is OFF.**
3. The Charging Port is located below the front edge of the seat bottom as shown.
4. First insert the Charger DC plug into the Charging Port and then insert the charger into the wall socket.
5. After charging is complete (at least 8 hours, but not more than 15 hours) unplug the Charger from the wall outlet.
6. Unplug the Charger from the Charging Port.

NOTE: The charger may feel warm during the charging. This is normal and not a cause for concern. If excessively hot, unplug and replace.

Drive Battery Replacement and Disposal

The drive battery will eventually lose the ability to hold a charge. Depending on the amount of use, and varying conditions, the battery should operate for one to three years. Follow these steps to replace and dispose the battery:

1. Remove the seat.
2. Disconnect the battery connectors.
3. Remove the metal battery bracket.
4. Carefully lift the battery.
 - Depending on the condition of the battery (i.e.: leakage) you may want to wear protective rubber gloves before removal.
 - Do not lift the battery by its connectors or cables.
5. Place the dead battery in a plastic bag.

Important!

- The sealed lead-acid battery must be recycled or disposed of in an environmentally sound manner.
- Do not dispose of battery in a fire. The battery may explode or leak acid.
- Do not dispose of the battery in household trash. The incineration, land filling or mixing of sealed lead-acid batteries with household trash is prohibited by law.
- Return an exhausted battery to a federal or state approved lead-acid battery recycler, such as a local seller of automotive batteries (check local battery disposal regulations).

NOTE: Replacement batteries are available at most battery supply stores. Document battery size and type (found on battery).

6. Install replacement battery and reconnect the connectors.
7. Replace the metal battery bracket.
8. Replace the seat.

Battery storage

The drive battery should be charged when depleted, or if not used regularly, once a month. Failure to charge the battery as directed will cause permanent damage to the battery and will void the warranty.

Follow these guidelines if the battery is removed:

- Do not store battery in extreme hot or cold temperatures.
- Do not place the battery on cement floors for extended periods. This will result in battery discharge. Store the battery on a wood surface.
- Wipe the battery clean with a dry cloth prior to storage. Wash cloth separate from other clothes.

Troubleshooting Guide

The following are examples of potential problems. Completely read through this manual and the troubleshooting guide table before calling. If you still need help resolving the problem please contact Customer Service.

Problem	Possible Cause	Solution
Vehicle does not run	Battery low on power	Recharge battery (see Battery: Recharge interval and time)
	Thermal fuse has tripped	Let Fuse reset (approx. 5 minutes)
	Battery connector or wires are loose	Check that the battery connectors are firmly plugged into each other. If wires are loose around the motor call Customer Service.
	Battery is dead	Replace battery (see Battery: Replacement and Disposal)
	Electrical system is damaged	Call Customer Service.
	Motor is damaged	Call Customer Service.
Vehicle does not run very long	Battery is under charged.	Check that the battery connectors are firmly plugged into each other when recharging (see Battery: Recharge interval and Time)
	Battery is old	Replace battery (see Battery: Replacement and Disposal)
Vehicle runs sluggishly	Battery low on power	Recharge battery (see Battery: Replacement and Disposal)
	Battery is old	Replace battery (see Battery: Replacement and Disposal)
	Vehicle is overload	Reduce weight on vehicle (see user requirements and Safety Warnings)
	Vehicle is being used in harsh conditions	Avoid using vehicle in harsh conditions (see User Requirements and Safety Warnings)

continued >>

Troubleshooting Guide - continued

Problem	Possible Cause	Solution
Vehicle will not run when foot pedal is pressed and shift lever is in the forward or backward position	Poor contact of wires or connectors	Check that the battery connectors are firmly plugged into each other. If wires are loose around the motor call Customer Service.
	“Dead Spot” on motor	A dead spot means the electric power is not being delivered to the terminal connection and the vehicle needs repair. Call Customer Service.
Difficult shifting from forward to reverse or vice-versa	Attempting to shift while the vehicle is in motion	Completely stop the vehicle and shift (see Use: Manual Operation)
Loud grinding or clicking noises coming from motor or gear box	Motor or gears are damaged	Call Customer Service.
	Drive Wheel is partially engaged	Check drive wheel - to motor engagement.
Drive Battery will not recharge	Battery connector or adapter connector is loose	Check that the battery connectors are firmly plugged into each other.
	Charger not plugged in	
	Charger is not working	Check that the battery charger is plugged into a working wall outlet.
	Battery is dead	Replace battery.
Charger feels warm when re-charging	This is normal and not a cause for concern	If excessively hot, unplug and replace.

Limited Warranty

Your purchase includes the following limited warranty, which is in lieu of all other express warranties. This warranty is extended to the initial purchaser only. Warranty registration is not required. This warranty gives you specific legal rights: you may have other rights, which vary from state to state.

The Vehicle and its component parts are under warranty to be free from faulty materials and workmanship from the date of the original purchase as follows:

- Drive Battery - 30 days
- Electronics - 90 days
- All other Components - 6 months
- All parts are subject to the Conditions of Warranty below.

Conditions Of Warranty

- It is the responsibility of the original consumer to ensure all parts included in the factory sealed carton are properly installed and that all functional parts are working properly.
- This Vehicle has been designed for general transportation and recreational use. This warranty shall become immediately null and void if you do any of the following:
 - Rent the Vehicle
 - Sell the Vehicle
 - Give away the Vehicle
 - Use Vehicle in ways conflicting with use and warnings described in this manual.
- The user assumes all risk of personal injuries, damage to, or failure of the Vehicle and any other losses if the Vehicle is altered in any way or if the Vehicle is used for stunt riding, ramp jumping, acrobatics or similar activities, or is towed by another person or vehicle.
- This warranty does not cover ordinary wear and tear, damage caused by improper storage of the Vehicle, shipping damage, damage caused either accidentally or deliberately by you or another, and damage caused as a result of using the Vehicle other than for its intended purpose.

How do you get service?

Contact Huffy Consumer Service.

See included list for Customer Contact information.

This product meets ASTM F963 and CPSIA requirements for electric vehicles.



WARNING: ALWAYS WEAR YOUR HELMET WHEN RIDING THIS PRODUCT!

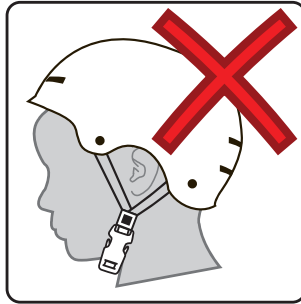
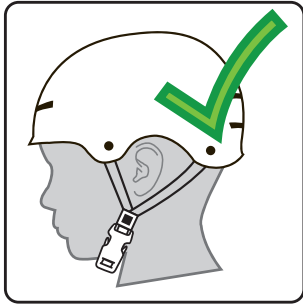

- Helmet should sit level on your head and low on your forehead
- Adjust the strap sliders below the ear on both sides.
- Buckle the chin strap. Adjust strap until it is snug.
- No more than two fingers should fit between the strap and your chin.
- A proper fitting helmet should be comfortable and not rock forward/backward or side to side.
- Always read the user manual that comes with your helmet to make sure it is fitted and attached properly to the wearer's head according to the fitting instructions described in the user manual.

HUFFY