

Dimplex®

2KW CERAMIC HEATER

DHCER20

User Manual



Please read the instructions carefully before using the product and keep this user manual for future reference.

1. PRODUCT FEATURES

- 2kW heat output
- Choice of heat settings
- Tip over safety protection
- Oscillating function
- Manual controls
- IP21 rated for bathroom use
- 12 month warranty

2. SAFETY WARNINGS

- Please operate the heater on a dry even surface.
- This appliance is not intended for use by persons (including children) with reduced physical, sensory or mental capabilities, or lack of experience and knowledge, unless they have been given supervision or instructions concerning the use of the appliance by a person responsible for their safety.
- Disconnect the heater from mains when not in use or cleaning.
- Do not operate the appliance with a damaged cord or plug. If the power supply cord is damaged, it must be replaced by the manufacturer or its service agent or a similarly qualified person in order to avoid a hazard.
- It is not recommended to use an extension cord or power board on this appliance.
- Do not immerse cord, plug or any part of the appliance in water or any other liquid.
- Do not place the heater on or near any other source of heat.
- **WARNING: do not cover the heater. This may cause the unit to overheat.**
- A fire may occur if the heater is covered with or touches flammable material, including curtains, drapes, bedding etc. When in operation KEEP THE HEATER AWAY FROM SUCH MATERIALS.
- Do not use the heater in the immediate surroundings of bathtubs, showers, washing stands or swimming pools.
- Do not use the heater outdoors.
- When the heater is turned on for the first time, it may release a slight, harmless odor. This odor is a normal occurrence caused by the initial heating of the internal heating elements and should not occur again.
- Do not operate the heater in areas where flammable liquids are stored.
- Do not operate the heater in close proximity to curtains or other combustible materials. Keep any combustible materials at least 1.0m away from the heater.

3. PARTS DESCRIPTION

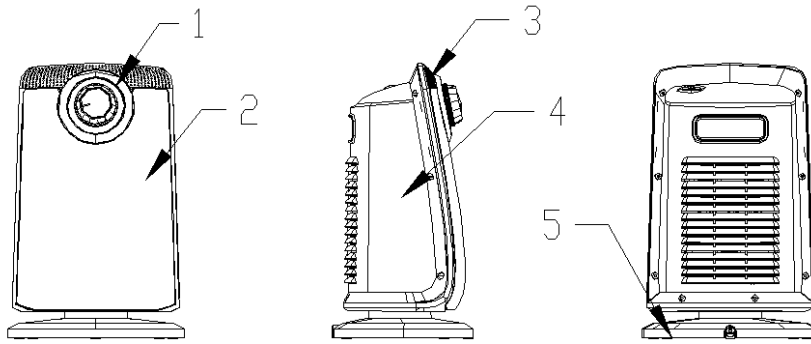

- | | | | |
|----|---------------|----|-------------|
| 1. | Control Panel | 2. | Heat Outlet |
| 3. | Front Cover | 4. | Back Cover |
| 5. | Base | | |

4. OPERATING INSTRUCTIONS

First, connect the power cord to the correct power supply (220-240V~/50Hz/ 10 amps).

Display Panel

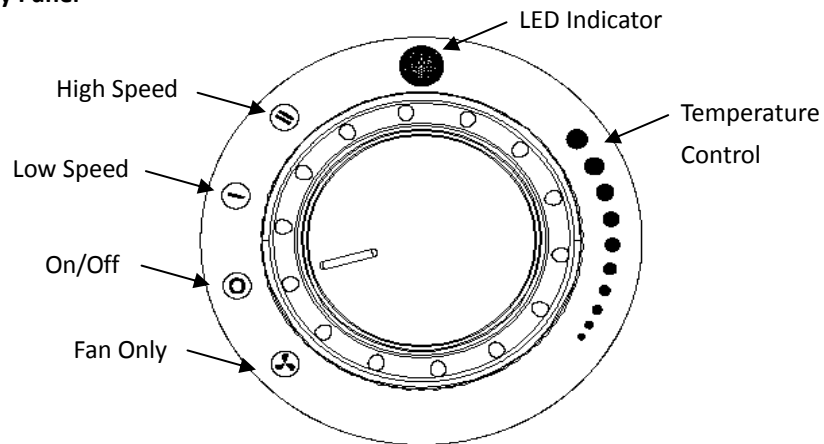

Power Setting Knob

- Rotate the knob to the "Power" position to turn the unit on or off.
- Rotate the knob to the "Low Speed" position to turn the unit on at low heat.
- Rotate the knob to the "High Speed" position to turn the unit on at high heat.
- Rotate the knob the "Fan Only" position to provide fan only operation.

Operational Panel

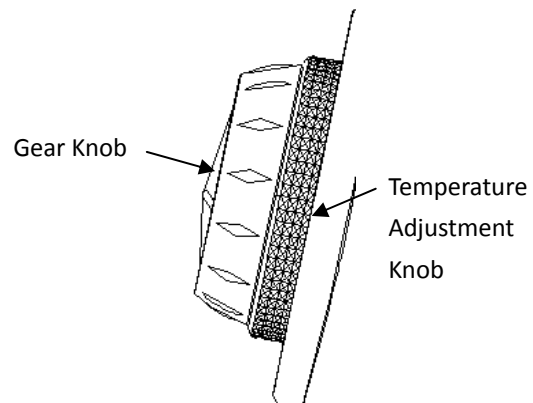

Temperature Adjustment Knob

- Rotate the temperature adjustment knob to set your desired temperature.
- Turn in counterclockwise direction for higher temperatures.
- Alternatively, turn clockwise for cooler temperatures.

5. CLEANING AND MAINTENANCE

Make sure the power switch is turned off and the plug is disconnected from the socket before cleaning or maintenance. Otherwise, it may cause an electric shock.

Cleaning the unit's surface:

Clean the surface with a damp cloth (or add some detergent). Do not use corrosive detergent or solvent to clean, such as Petrol/ Turpentine etc. Do not wash the unit directly with water.

Cleaning the air filter monthly:

Dirt and dust may get caught in the filter during operation. Cleaning is required to avoid any damage to the unit. This should be done at least once a month.

- Use a soft cloth to wipe the dust/dirt. If you use water for cleaning, please make sure the air filter is dry before reinstalling it.
- Do not use chemicals for cleaning.

• 7. SPECIFICATION

Model No.	DHCER20
Product name	2kW Ceramic Heater
Voltage/Frequency	220-240V~/50Hz
Power	1300/2000W
Noise	≤50dB
Product size	347h x 222w x 177d (mm)
N.W.	2kg
G.W.	2.75kg
	 5336



DISPOSAL: Do not dispose this product as unsorted municipal waste.
Collection of such waste is required to be disposed of separately.

Glen Dimplex Australia Pty Ltd

Unit 1, 21 Lionel Road

Mount Waverley VIC 3149

Phone: 1300 556 816

Fax: 1800 058 900

Email: sales@glendimplex.com.au

Glen Dimplex Australasia Ltd

38 Harris Road

East Tamaki, Auckland

Phone: 09 274 8265

Fax: 09 274 8472

Email: sales@glendimplex.co.nz