

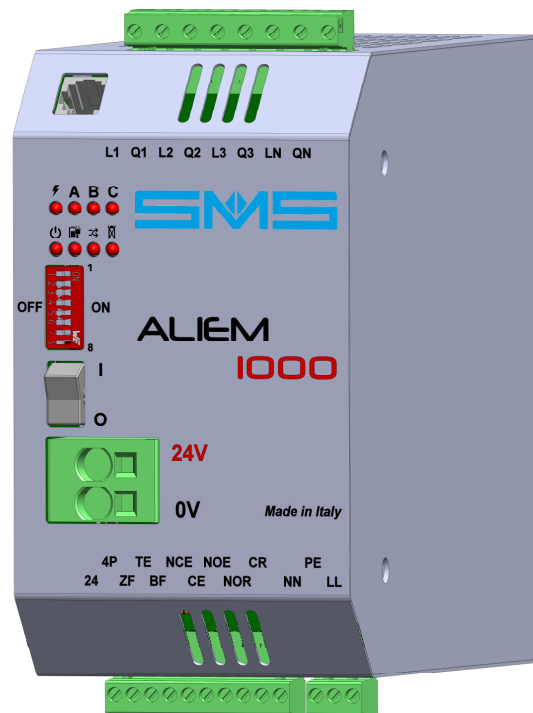

# ALIEM 1000

## USER MANUAL



Draft_04	08-10-2015	D. Cavalli
REV.	DATE	Checked and Approved R. T.

PAGE INTENTIONALLY LEFT BLANK

# 1 – INTRODUCTION

**ALIEM 1000** is an emergency power supply able to reproduce the THREE-PHASE voltage 400V 50/60Hz, by using the voltage 24Vdc supplied by 2 batteries.

As an alternative to this, that its specific use, it's possible also the SINGLE-PHASE operation (input and output 1~230Vac), as described in Chapter 5.1.

**ALIEM 1000** installation then makes possible to move the lift even in the absence of mains voltage.

During the stand-by phase, in addition to recharging the batteries, **ALIEM 1000** checks their efficiency.

It is available in a single size, **1000VA** (see Section 3 ).

# 2 - IMPORTANT SAFETY WARNINGS

Read this manual carefully before proceeding with installation or maintenance.

Safety warnings do not cover all the causes of device failure, but provide information on the most common causes:

The following symbols appear in this document or on the equipment to warn the user on potential hazards and require special attention.



THIS SYMBOL INDICATES AN ELECTRICAL SHOCK HAZARD.



THIS SYMBOL INDICATES TO PAY CLOSE ATTENTION .

	If the device is visibly damaged, if components are missing, or if the power required is greater than the power provided by the device, do NOT proceed with the installation.
	When the device is connected to the line, it is subjected to dangerous voltages. Installation, inspection and maintenance of the device must be performed by authorized personnel adequately trained and must be carried out only when it is isolated from the mains and from the batteries. Improper installation may result in malfunction of the equipment, injury or even death. <i>Carefully</i> follow the safety regulations in force
	The device must be connected to the GROUND and the circuits must be protected adequately, in accordance with the regulations in force.
	To ensure the correct operation of the device and to prevent the risk of fire, use cables with appropriate cross section in accordance with the current and the connection length.
	Make sure no external object enters the device as it can lead to the malfunction <i>of the product</i> or hazardous conditions <i>when connecting</i> to the mains or the batteries. Make sure that the control terminals of the device are not subjected to voltage with powers referred to the electrical network. The control and power conductors must be carefully isolated from each other.

**The examples and the diagrams contained in this manual are for demonstration purposes only.**

**The contents of this manual is subject to change without notice.**

**The manufacturer declines all liability for damages, either indirect or consequential, arising from the use or application of the device.**

### 3 – TECHNICAL SPECIFICATIONS

Rated Power	1000VA
Maximum Power Peak	1500VA
Allowed mains voltage	400V 50Hz (380-10% ÷ 400 +10%)
Batteries	N°2 12V 18Ah
Rated current (DC)	50A (*)
Maximum rated current (DC)	75A (*)
Operating Voltage	>19V <27,5V
Room temperature	0 ÷ 50°C
Degrees of Protection	IP20

(\*) At maximum output power

#### 3.1 – ALIEM 1000 CODE FORMAT

The code shown on the label describes some technical features that uniquely identify the product.

**ALM 1000 S. 4 T 2**

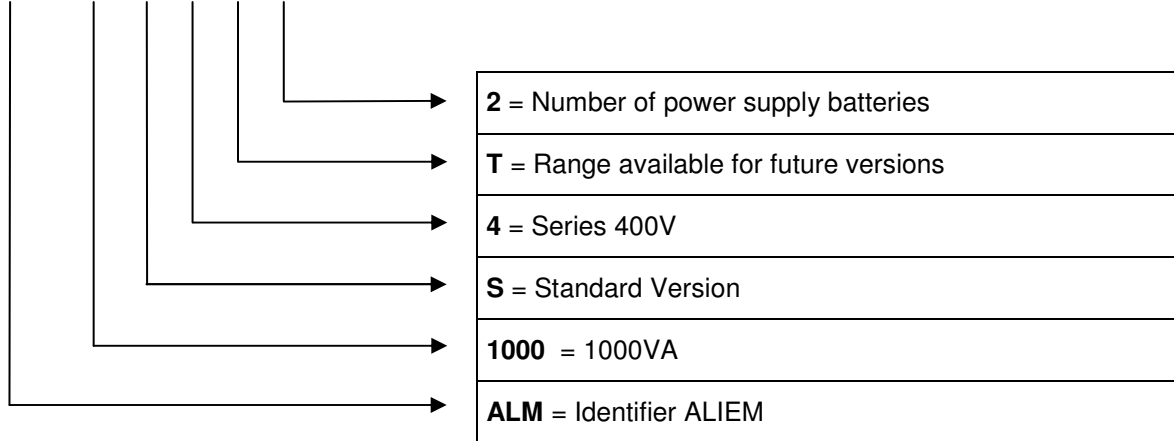

#### 3.2 – PROTECTION FUSES



In order to protect the circuits connected to the network and prevent hazardous conditions in the event of external short circuit, it is recommended to insert upstream of the power line (L1-L2-L3) 3 fuses type gG with trigger current below 4A

### 4 – WIRING

The electrical connections to the device **ALIEM 1000** must be performed by respecting the insulation and the maximum temperatures allowed for the cables.

The Table shows the minimum cross sections referred to cable type N07V-K.

Terminals <b>L1-L2-L3-LN - Q1-Q2-Q3-QN</b> (Line)	1.5mm <sup>2</sup>
Terminals <b>NN-PE-LL</b> (Battery charger)	16mm <sup>2</sup>
Terminals <b>0 – 24</b> (Batteries)	16mm <sup>2</sup>
Terminals <b>24-4P-ZF-TE-BF</b> (Control inputs/outputs)	1 mm <sup>2</sup>
Terminals <b>NCE-CE-NOE-NOR-CR</b> (Relay outputs)	1.5mm <sup>2</sup>

## 4.1 – CONNECTION TO THE MAINS

On the upper part of the device are fitted 8 terminals labelled **L1-L2-L3-LN-Q1-Q2-Q3-QN**, through which **ALIEM 1000** is placed between the mains power supply (input L1-L2-L3) and the primary circuit of the operating transformer (output Q1-Q2-Q3).

Inside the device are fitted relay contacts which, during normal operation, transfer the power of the network to the load.

In case of main power failure, these contacts open automatically to isolate the electrical network, and **ALIEM 1000** generates a THREE-PHASE voltage with neutral on Q1-Q2-Q3-QN, for powering the operating transformer even in this condition.

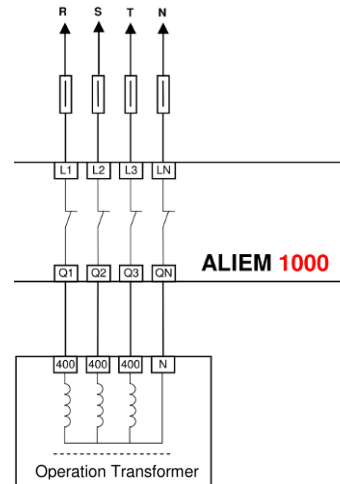

The maximum current that can circulate on terminals L1-L2-L3-LN-Q1-Q2-Q3-QN is **4A**. Greater currents can cause hazardous conditions and damage to the device.

## 4.2 – CONNECTING THE BATTERY CHARGER

**ALIEM 1000** comes with an internal charger, which must be supplied with a voltage of 230V 50/60Hz (+ / -10 %) on terminals **LL-NN**.

This power does not necessarily have to be interrupted during the emergency cycle and can, therefore, be directly connected to the mains.

No external fuses are required, because the device is already equipped with appropriate protections.

## 4.3 – BATTERY CONNECTION

On the front panel are fitted the terminals **0-24** for the battery connection.

External fuses are not required, because **ALIEM 1000** is equipped with appropriate protections, including protection against connection with reversed polarity.

## 4.4 – CONNECTION OF CONTROL CIRCUITS

### INPUTS

The controls for the inputs of **ALIEM 1000** must be provided with dry contacts, referred to the 24Vdc voltage, present on terminal 24 of the device.

**Minimum operating current = 3mA.**



By connecting the inputs at voltages higher than 30Vdc or with power referring to different voltages, they may be damaged.

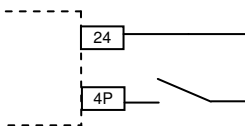

### 4th POLE Input (4P) :

With active input (contact closed) the device is enabled to function.  
With input inactive (contact open), the device is not enabled for operation.  
The opening of the contact during the emergency operation immediately cuts off voltage supply, bringing the device in standby condition.

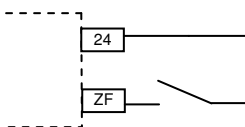

### EMERGENCY END input (ZF):

The input is only checked during the emergency cycle and the user can choose, via a switch, if the end of the emergency cycle corresponds to the contact that opens (N.C.) or that closes (N.O.).  
When the "emergency end" option is inactive, the device provides the emergency power supply continuously.  
When the above option is active, **ALIEM 1000** waits for a time programmable via Dip-switch and then stops the emergency cycle, returning to stand-by mode.

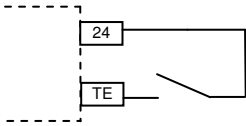

### MANUAL OPERATION (TE) input:

The input allows **ALIEM 1000** to start an emergency cycle even in the presence of network voltage.

When the input is active (closed contact), the emergency cycle is enabled.

When the input is inactive (open contact) the device returns to standby mode.

## OUTPUTS

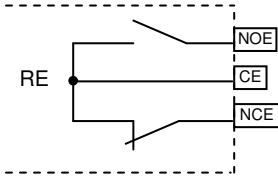

### RE Relay Output → EMERGENCY CYCLE IN PROGRESS

Internal dry contact:

Switching power: 250Vac / 3A – 30Vdc / 3A

The RE output is active from the beginning to the end of the emergency cycle. It can be used to control any external breaker that isolates the network (see Diagrams Chap.9).

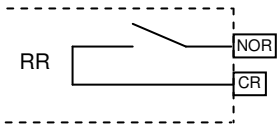

### RR Relay Output → TIMED EMERGENCY

Internal dry contact:

Switching power: 250Vac / 3A – 30Vdc / 3A

The RR output is activated with a delay of 2 seconds in relation to RE output and is disabled 2 seconds earlier. It can be used to control any contactor that enables motor inverter power supply, directly via **ALIEM 1000** or batteries (see Diagrams Chapter 9).

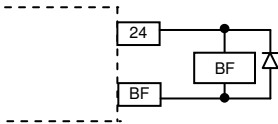

### BF Output → BATTERY STATE MONITOR

**ALIEM 1000** is equipped with a sophisticated system for checking the battery efficiency.

The battery check is performed by **ALIEM 1000** during the stand-by phase, if the batteries are no longer efficient and must be replaced, output BF will be activated. By connecting a relay between terminals BF and 24, this information can be used for remote diagnostics.

The BF output works in a different way during the emergency phase: at the beginning of the emergency cycle, the BF relay energizes and stays ON until eventually the overload protection trips. In this case **ALIEM 1000** cuts off the output power, then it automatically resumes it, but in this second step the BF relay is not energized.

So the BF relay can be used in the control panel to switch the direction commands, in order to move the car in the opposite direction, which is supposed to be the most favourable one.

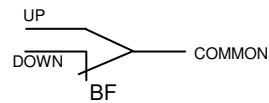

## 5 – OPERATION

**ALIEM 1000** detects the mains power failure (even of one phase only) and, if the contact 4P is closed, after a few seconds it enables the emergency procedure:

- It activates the internal RE relay and cuts off the power supply which normally comes from the mains.
- After a proper delay, it activates the RR relay and then it turns on the converter, which reproduces the supply voltage on terminals Q1-Q2-Q3-QN.
- At the activation of the external control of "Emergency End" (ZF), **ALIEM 1000** waits for a programmable time, then turns off the converter by interrupting the power supply on output terminals Q1-Q2-Q3-QN, then disables the RR relay.
- After 2 seconds, it returns to standby mode, disabling the RE relay, and connects again the operating transformer to the mains.

The maximum time allowed for the emergency cycle is 2 minutes.

If the overload protection trips, **ALIEM 1000** will try a second starting. At the next starting, the BF output is not activated any more, this to allow the control panel, with appropriate wiring, to make the lift to move in the opposite direction.

A new emergency operation will only be possible after the restoration of the mains supply, and a subsequent lack thereof.

**ALIEM 1000** can also be activated via an external control, both in the presence and in the absence of mains voltage.

### 5.1 – SINGLE-PHASE OPERATION VERSION

In case of single-phase mains supply 230Vac, the input voltage shall be connected to terminals L1 – LN, while the output voltage shall be taken from terminals Q1 – QN.

## 6 – SETTINGS

DIP	TIPO	OFF	ON	
1	Activation Delay Time	2 seconds	10 seconds	
2	ZF Input Function	Opens at Floor	Closes at Floor	
3	Shutdown Delay Time	<b>DIP 3</b>	<b>DIP 4</b>	
		OFF	OFF	15 seconds
		ON	OFF	10 "
4		OFF	ON	5 "
		ON	ON	0 "
5	Not used	/	/	
6	Mains frequency	50Hz	60Hz	
7	Mains Supply Type	Three-phase	Single-phase	

## 7 – SIGNALS

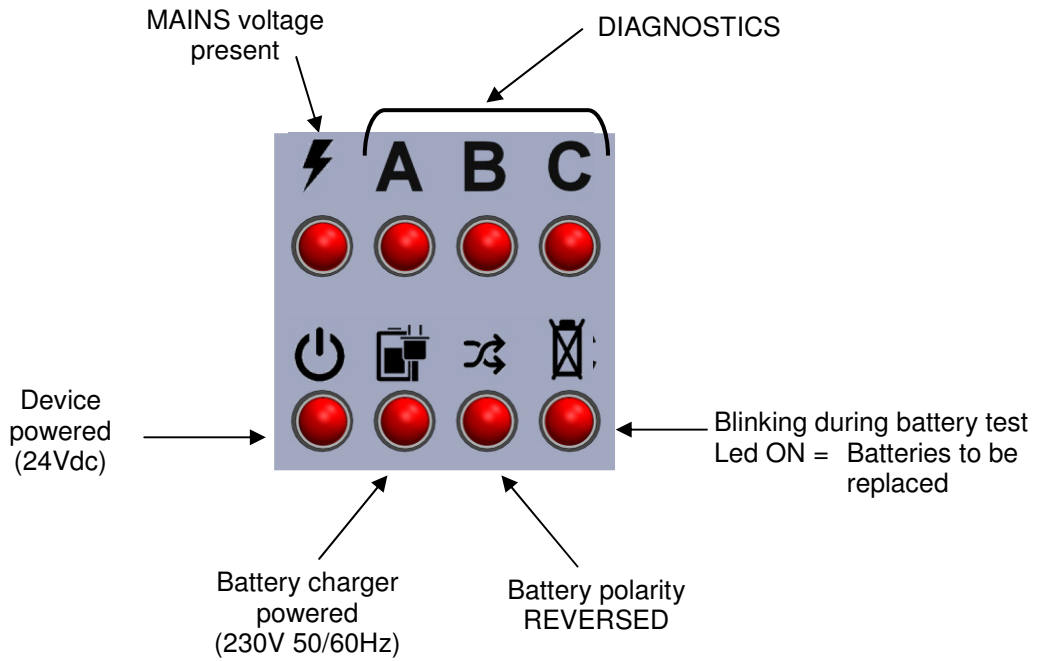

DIAGNOSTICS			
Led A	Led B	Led C	Description
○	○	✱	Device "Ready"
●	○	✱	Emergency Running
●	●	✱	Car in the stop zone
✱	●	●	High Voltage Inverter Overcurrent
✱	●	○	Low Voltage Inverter Overcurrent
✱	○	●	Battery Alarm
✱	✱	●	Overtemperature
✱	○	✱	Overload (Max. 4 seconds)

**Notes**

○ = Led OFF

● = Led ON

✱ = Led FLASHING

## 8 – SAFEGUARDS

- ◆ Block in case of overcurrent during the emergency cycle.
- ◆ Check battery efficiency.
- ◆ Maximum operation time: 2 minutes.
- ◆ Overtemperature.
- ◆ Overload.
- ◆ Battery Voltage too high or too low.



## 9 – APPLICATION DRAWINGS

INVERTER SPECIFICATIONS		
Inverter arranged for <b>Emergency Operation</b>	Inverter arranged for <b>Emergency "Battery Saving" Operation</b>	Inverter <b>arranged or not for Emergency Operation</b> (without check on the input phases)

<b>GEARLESS</b>	<b>YES</b>	<b>YES</b>	
<b>GEARED</b> (Motor Power ≤ 4kW)	<b>YES</b>		<b>YES</b>
<b>GEARED</b> (Motor Power > 4kW)	<b>YES</b>		<b>NO</b>

<b>Notes</b>	ALIEM powers the Inverter only to switch it on ( <b>Application Type 2</b> ) or only its control circuit ( <b>Application Type 1</b> ). The power requested by the motor comes from the batteries.	ALIEM powers the Inverter in L1-L2 during the whole emergency cycle ( <b>Application Type 3</b> ). The power requested by the motor comes from ALIEM.	ALIEM powers the Inverter in L1-L2 during the whole emergency cycle ( <b>Application Type 3</b> ). The power requested by the motor comes from ALIEM.
--------------	--	---	---

\* With direction switching circuit (See description Output BF, Chap. 4.4)

# APPLICATION DRAWING TYPE 1

## Control Panel Supply and Inverter Auxiliary Supply by ALIEM 1000 Inverter Power Supply by Batteries

Use this application in case of Inverter arranged for Emergency Operation with Batteries, with Auxiliary Supply 230Vac for the control circuit.



**IMPORTANT:** In this example Batteries 48V are considered.  
The voltage and the capacity of the batteries depend on the type of motor used (\*\*).

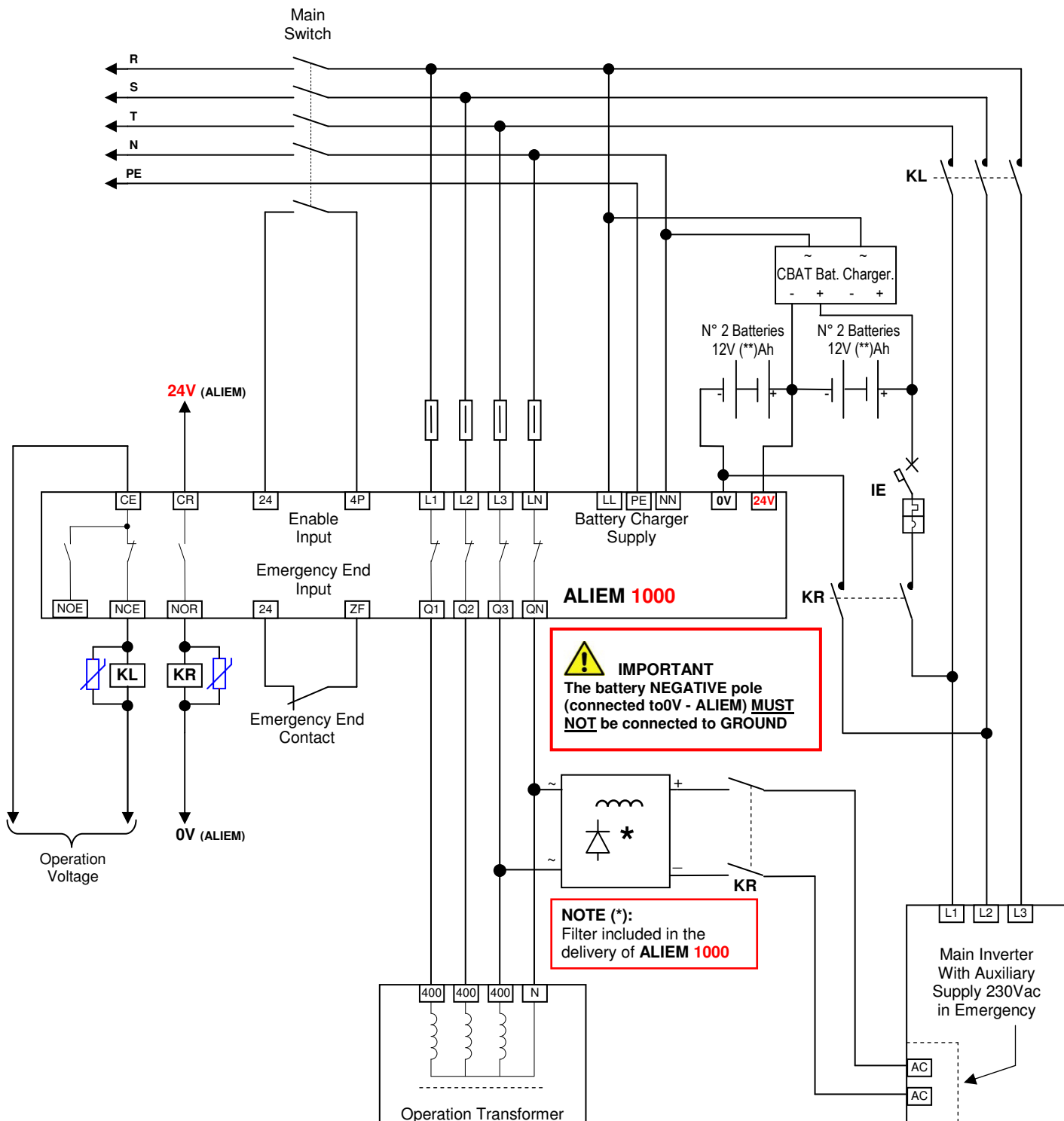

KL Line Contactor (closed in normal operation, open in emergency)  
KR Emergency Supply Contactor

# APPLICATION DRAWING TYPE 2

## Control Panel Supply and Inverter Auxiliary Supply by ALIEM 1000 Inverter Power Supply by Batteries

Use this application in case of Inverter arranged for Emergency Operation with Batteries, with Temporary Auxiliary Supply 230Vac on L1-L2 for the control circuit (for example, VACON V20).



**IMPORTANT:** In this example Batteries 96V are considered.  
The voltage and the capacity of the batteries depend on the type of motor used (\*\*).

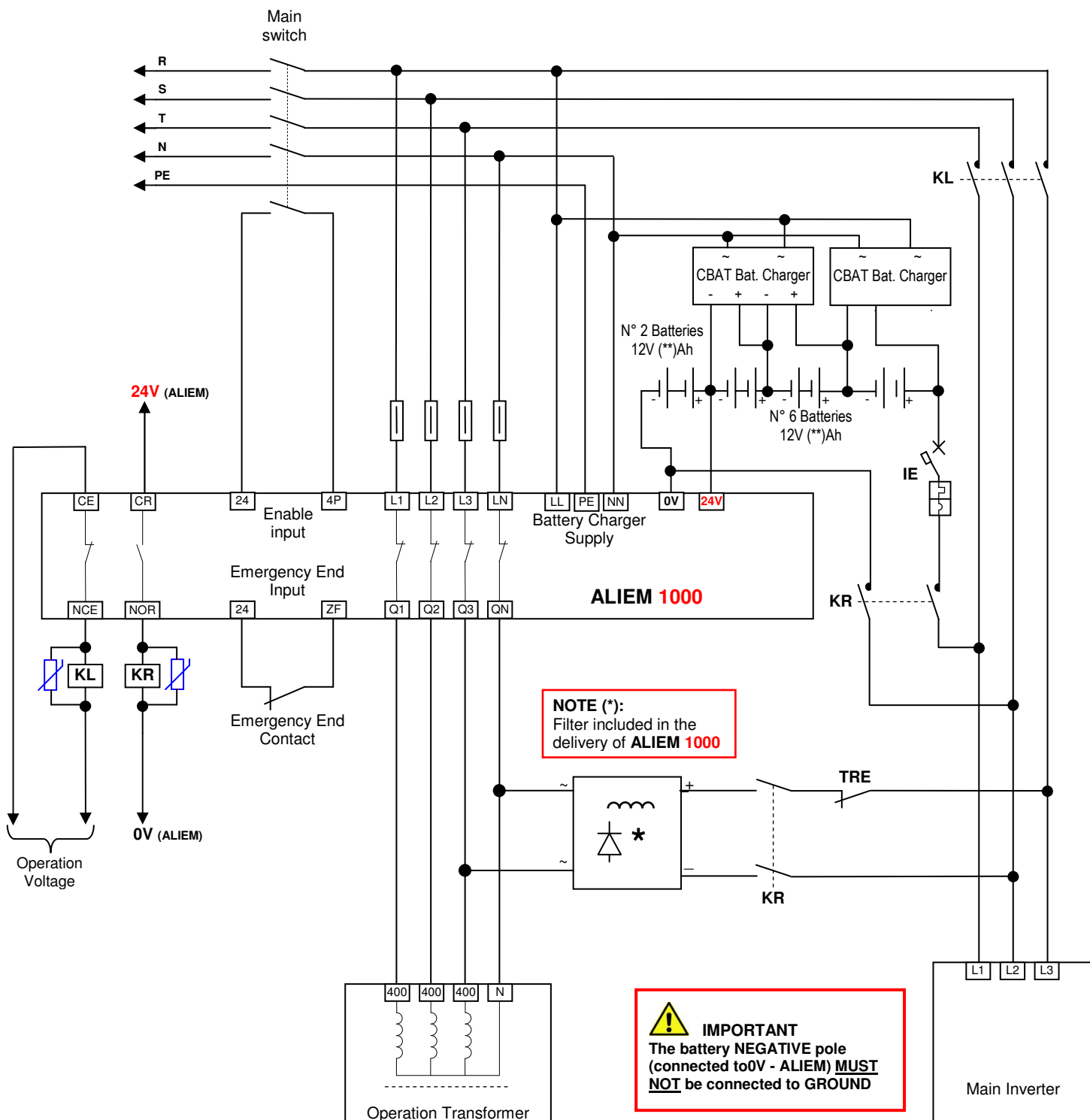

- KL Line Contactor (closed in normal operation, open in emergency)
- KR Emergency Supply Contactor
- TRE Timer to switch off the auxiliary supply after 3-5sec.(before the inverter switches on the power output)

# APPLICATION DRAWING TYPE 3

## Control Panel and Main Inverter Supply by ALIEM 1000

Use this application in case of geared lift system with asynchronous motor **MAX 4kW** or in case of gearless lift system with inverter provided with "Battery Saving" option.

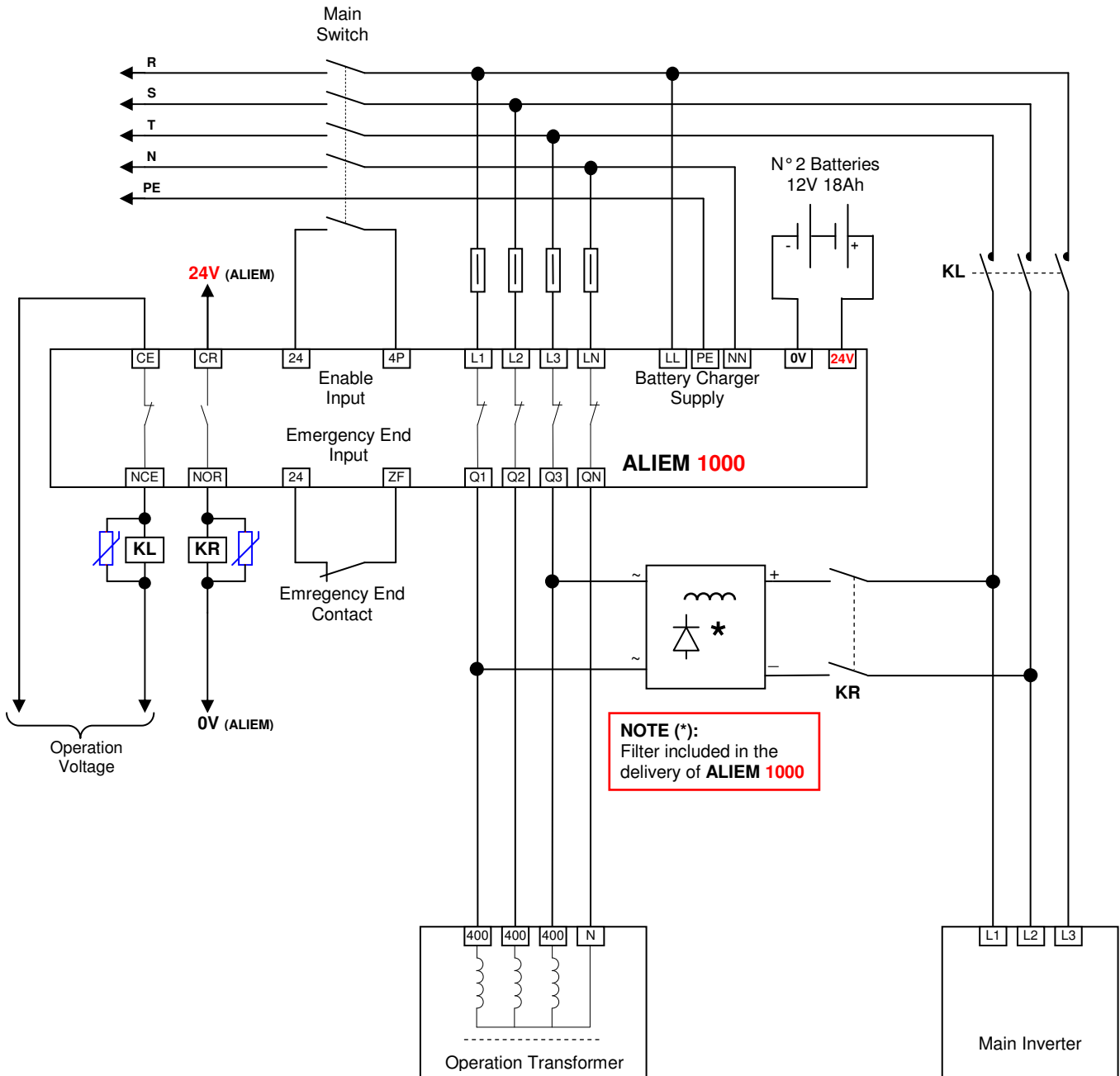

- KL Line Contactor (closed in normal operation, open in emergency)
- KR Emergency Supply Contactor

# 10 – TROUBLESHOOTING

IN PREPARATION

# 11 – DIMENSIONS AND WEIGHT

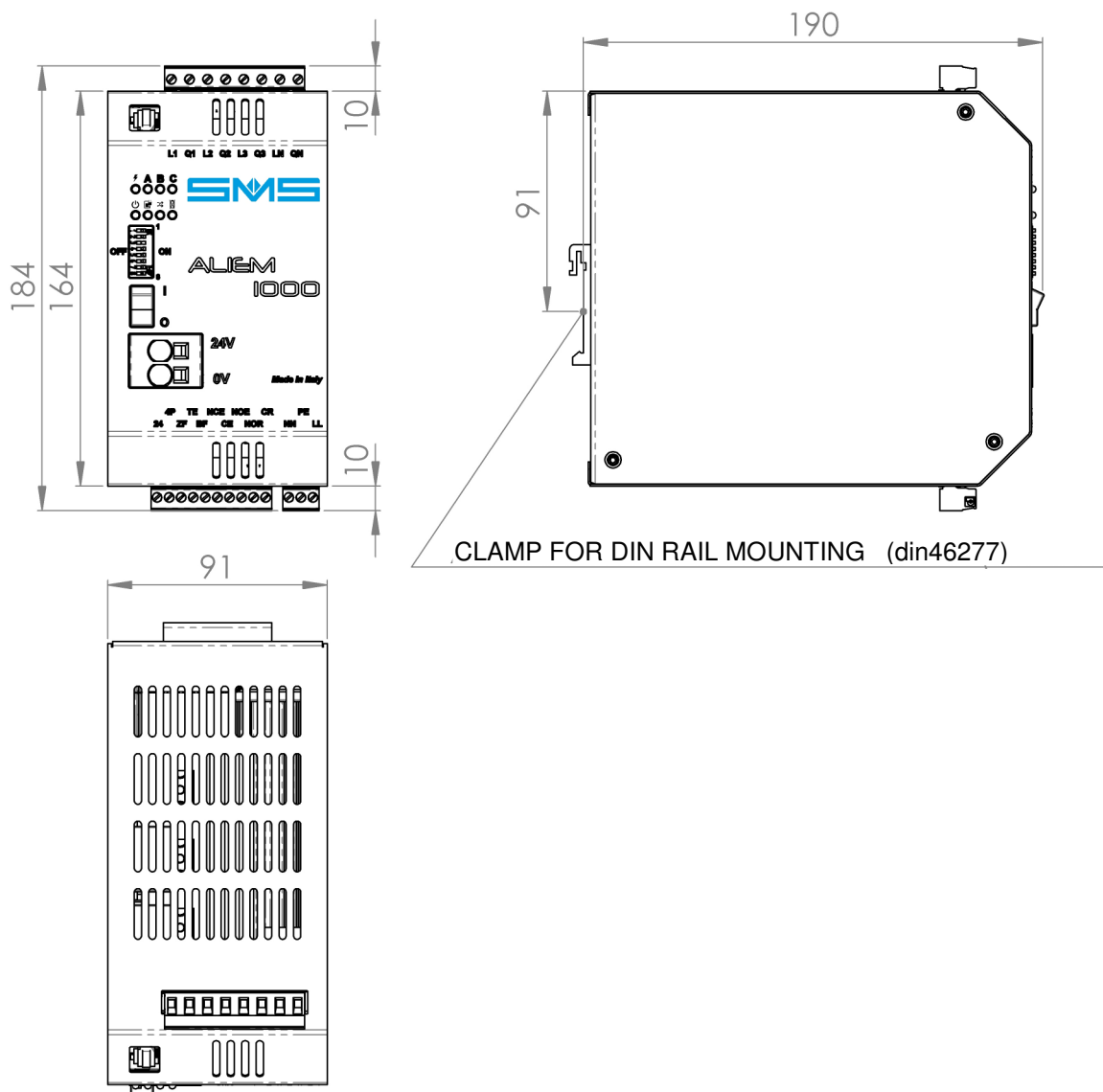

- WEIGHT about 2kg

For further clarifications and suggestions please contact:

**SMS SISTEMI e MICROSISTEMI s.r.l. (SASSI HOLDING group)**

Via Guido Rossa, 46/48/50 Loc. Crespellano 40053 Valsamoggia BO - ITALY

Phone: +39 051 969037 Fax : +39 051 969303 Technical Support: +39 051 6720710

E-mail: sms@sms.bo.it website : [www.sms-lift.com](http://www.sms-lift.com)