

DARAY[®]

Medical



SL400 Series

Operating Theatre Light

User Manual & Installation Guide

QAM.SL400LED.0915.13

Contents

1. Introduction.....	3
1.1 Supported Lights	3
1.2 Lighting Specification	4
1.3 Pre-Installation Responsibilities and component packing list ...	4
1.4 Packing List	4
1.5 Essential adjustment information	6
2. Operation Guide Section	8
2.1 Range of Motion	9
2.2 Pre-Start Checks	10
2.3 Battery Back-up	10
2.4 Powering On & Variable Intensity	10
2.5 Adjusting the Lighthead.....	11
2.6 System Mounted HD Camera	12
3. Installation Guide Section	13
3.1 Considerations.....	14
3.2 Ceiling Mounted Lights	14
3.2.1 Attachment methods and void suspension	15
3.2.2 Bolting Advice.....	15
3.3 Lighting configuration	15
3.3.1 Affixing the Ceiling plate.....	15
3.3.2 Fixing the arms and main installation	17
3.3.3 Wiring and transformer layout.....	20
3.3.4 Attaching the Ceiling Cover	22
3.4 Wall Mounted Bracket Assembly	23
3.4.1 Considerations	24
3.4.2 Bolting Advice.....	24
3.4.3 Placement and Installation.....	24
3.5 Mobile Mount Assembly	27
4. Maintenance	30
4.1 Maintenance schedule.....	30
4.2 Safety Precautions	30
4.3 Cleaning	30
4.4 Fuses and their replacement	30
4.5 Adjustments	31
4.5.1 Replacing the LED Bulbs	33
5. Troubleshooting Guide	34
6. Warranty Information	35
6.1 Returns Policy	35
6.2 Warranty Details	36

1. Introduction

Thank you for choosing a Daray SL400 Series Operating Theatre Light.

The SL400 Series of lights are specifically designed to meet the demanding needs of today’s medical department whilst providing the finest quality design with superior performance, reliability and value. This manual has been provided to give detailed descriptions covering the performance, operation and safety information of the device. It’s recommended that users read through this manual before using the device so they are aware of how to operate the device and all of its features appropriately.

This user & installation guide contains all the information you need for installation, operation and maintenance of the lights and additional camera option.

Restrictions and Liabilities

Information in this document is subject to change and does not represent a commitment by DARAY. Changes made to the information in this document will be incorporated in new editions of the publication. No responsibility is assumed by DARAY for the use or reliability of software or equipment that is not supplied by DARAY

For further information on our product range and find out more about our company please visit www.daray.co.uk or call **0333 321 0971**

This product was designed & manufactured in Great Britain by:

Daray Ltd.
Marquis Drive, Moira
Swadlincote
Derbyshire
DE12 6EJ

1.1 Supported Lights

The Following Models are supported in this Manual	
SL450	Ceiling Mounted
	Wall Mounted
	Mobile Mounted
SL470	Ceiling Mounted
	Wall Mounted
	Mobile Mounted
SL450 / 470	Double Ceiling Mounted
SL450 / 450	Double Ceiling Mounted
SL470 / 470	Double Ceiling Mounted

1.2 Lighting Specification

	SL470/470LED	SL470/450LED	SL450/450LED	SL470LED	SL450LED
Luminance Lx	40,000-160,000	30,000-160,000	30,000-120,000	40,000-160,000	30,000-120,000
Colour Temp	4,300 ± 500k				
CRI	Up to 95				
R9	97				
R13	93				
Spot diameter (d10)	120-350mm	120-350mm	120-350mm	120-350mm	120-350mm
Focusing depth mm	≥1000	≥1000	≥1500	≥1000	≥1500
Irradiancy L400nm W/m ²	Ee: ≤1000W/m ² , Ee/Ec: ≤ 6m W/m ² (Ceiling/Mobile Mount) Ee: ≤1000W/m ² , Ee/Ec: ≤ 4m W/m ² (Wall Mount)				
Number of LEDs	72 Clusters (216 LED's)	54 Clusters (162 LED's)	36 Clusters (108 LED's)	36 Clusters (108 LED's)	18 Clusters (54 LED's)
LED power:	108W / 108W	108W / 54W	54W / 54W	108W	54W
LED voltage:	3.2V DC				
Input voltage:	230V 50Hz, class 2 (double insulated)				
Power consumption:	2 x 200VA(dual-head) or 200VA(single-head)				
Net weight:	156Kg	124Kg	95Kg	78Kg	46Kg
Safety level:	CLASS I				
Fuse:	RT1-30, T4AL 250V				
Ceiling load capacity:	500+ KG				
Temperature Rise on Surgeon	≤2 °C				
Working environment temperature:	10 - 30 °C				
Relative humidity range:	≤75%				
Atmosphere range:	700-1060hpa				
Average service life	>50,000 Hours				
This equipment cannot be used where there is an air mixture of flammable anaesthetic gas and air or oxygen and nitrous oxide					
Transportation condition: environment temperature -40~+55°C, relative humidity: ≤93% atmosphere: 500-1060hpa					

1.3 Pre-Installation Responsibilities and component packing list

This document is a guide to the steps that need to be performed to correctly install the SL400 Series Operating Theatre Light System. However, the work required to be performed is the responsibility of the owner or designated contractors.

All fixings between Daray lights and the building super-structure must be approved by either the chief project engineer or an appropriate and competent structural assessor.

The components supplied by Daray for fitting / installation should be the following items in the specified quantities.

1.4 Packing List *(what you should have per light).*

SL470 Ceiling Mounted Light	SL450 Ceiling Mounted Light
1 Primary Lighthouse	1 Primary Lighthouse
1 Fixing Plate (Optional)	1 Fixing Plate (Optional)
1 Ceiling plate with pedestal	1 Ceiling plate with pedestal
1 Primary Rotation Arm	1 Primary Rotation Arm
1 Suspension Arm	1 Suspension Arm
1 Autoclavable Handle	1 Autoclavable Handle
1 Ceiling Mount Cover (1 suspended ceiling cover)	1 Ceiling Mount Cover (1 suspended ceiling cover)
(Optional Battery back-up, 1 per head)	(Optional Battery back-up, 1 per head)

SL400 Series Dual Mounted Ceiling Light
1 Primary Lighthouse
1 Secondary Lighthouse (satellite)
1 Fixing Plate
1 Ceiling plate with pedestal downtube, and pre-wired transformers
2 Ceiling Mount Cover Halves
2 Primary Rotation Arms
2 Suspension arms

1 Bag of inter-arm fixings and spare connectors
(Optional Battery back-up, 1 per arm)
2 Autoclavable handles (1 handle per head)

SL450 Mobile Mounted Pack List	SL470 Mobile Mounted Pack List
Lighthouse	Lighthouse
Mobile Base with 4 caster lockable wheels	Mobile Base with 4 caster lockable wheels
Lower vertical tubing	Lower vertical tubing
Upper vertical tubing	Upper vertical tubing
Suspension Arm	Suspension Arm
IEC Power Lead	IEC Power Lead

SL450 Wall Mounted Pack List	SL470 Wall Mounted Pack List
1 Primary Lighthouse	1 Primary Lighthouse
1 Wall Mount Bracket with pre-attached transformer and rotation arm	1 Wall Mount Bracket with pre-attached transformer and rotation arm
1 Suspension Arm	1 Suspension Arm

The ceiling mounted edition of the SL400 series lights has a recommended fixing point of 3 metres from the floor; the minimum height for the standard design is 2.7m. Anything over 3.1m, or systems using multiple satellites will require bespoke modification. Please contact Daray for further information.



Installation height:	2.7 - 3.1m Standard 2.4 - 2.7m LCH
Medical Products Safety class:	Class 1, type B
Working as:	Continuous operation
Temperature:	10°C–30°C
Relative humidity:	10%–80%
Power supply:	230V AC ±10%
Frequency:	50Hz±1%

1.5 Essential adjustment information

PLEASE NOTE: THE SUSPENSION ARM IS SENT OUT LOCKED IN A HORIZONTAL HEIGHT POSITION

For a detailed description of all these adjustments, please refer to pages 30-32 of this user manual. Once Installation is complete, light operation & manoeuvrability should be completely tested & adjusted as necessary.

Please Note: Arm adjustments will have a 'settling in' period, this means that they may start to drift again after being adjusted. This can happen multiple times and will require several adjustments by the end user to achieve desired results.

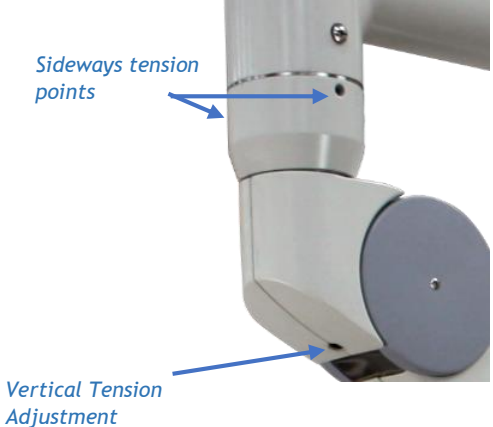
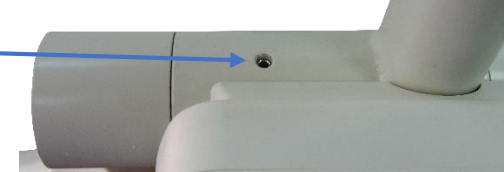
<p>Rotation arm - Sideways Drift The light can sometimes drift sideways, the first step to correcting this is to ensure that the downtube is vertically aligned (true). Note: if the downtube is not vertical the tension adjustments will not work</p> <p>If the downtube is completely vertical and drifting persists then the rotation arms can be adjusted using tension points located on the central arm boss.</p> <p>Adjustments should be made in quarter turns on each side of the arm boss (both sides need to be adjusted together). These adjustments apply brakes that should reduce / stop the drift of the arm.</p>	
<p>Suspension Arm height Please Note: The suspension arm is sent out locked in a horizontal position. Once the light is fully installed, the height of the arm will need to be adjusted using a keyhole tension point in the end of the suspension arm, where it connects to the lighthouse arm. To adjust the arms upper height limit insert a 5mm Allen key and turn in an anti-clockwise direction. (this feature is only available of standard models, not the low ceiling height version).</p>	
<p>Suspension arm Sideways drift (Horizontal) is controlled by a pair of grub screws on opposite sides of the spigot joint that connects the rotation and suspension arms. As with the rotation arm, the suspension arm can sometimes drift sideways, the first step to correcting this is to ensure that the downtube is vertically aligned (true). Adjustments should be made in quarter turns on each side of the arm spigot as indicated (both sides need to be adjusted together). These adjustments apply brakes similar to the rotation arm.</p> <p>Up/Down drift (vertical) is controlled by a tension adjustment located in a keyhole slot under the same spigot joint mentioned for the horizontal drift. Adjust the tension through the keyhole slot, move the light to its highest and lowest points to check for drift. Repeat this process until suitable.</p>	
<p>Lighthouse hinge arm The lighthouse is on a separate arm section, movement of this arm is adjusted via a grub screw located on the hinge behind the control panel on the arm. Be careful adjusting this as it could cause the lighthouse to swing. this can be adjusted using a hex tool.</p>	

Lighthouse turning

The lighthouse itself has one final tension point, this is located at the base of the head where it attaches to the arm system. Pictured here, this tension point controls the heads turning resistance.

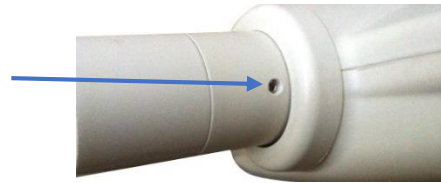

Wall mounted arm adjustments

Wall mounted systems use a similar arm design as the ceiling mounted version. However the adjustment screw is located at the top of the arm boss instead of at the bottom.

Note: if the wall mount is not vertical the tension adjustments will not work

If the unit is completely vertical and drifting persists then the rotation arm can be adjusted using the tension points located on the central arm boss.

Adjustments should be made in quarter turns on each side of the arm boss (both sides need to be adjusted together). These adjustments apply brakes that should reduce / stop the drift of the arm.



Mobile arm adjustments

Sideways drift (Horizontal) is controlled by a pair of grub screws on opposite sides of the spigot joint that connects the rotation arm to the mobile upstand.

If the surface the mobile unit is placed upon, is not flat, the mobile unit may drift.

If drifting persists then the rotation arm can be adjusted using the tension points located on the connection point between the arm and the upstand

Adjustments should be made in quarter turns on each side of the joint (both sides need to be adjusted together). These adjustments apply brakes that should reduce / stop the drift of the arm.

Up/Down drift (vertical) is controlled by a tension adjustment located in a keyhole slot under the same spigot joint mentioned for the horizontal drift. Adjust the tension through the keyhole slot, move the light to its highest and lowest points to check for drift. Repeat this process until suitable.

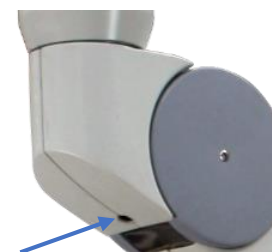

2. Operation Guide Section

2.2 Pre-Start Checks



Please check (when applicable) that the head and arms are without visible damage, and all LED's are present in the head.



Please note, the SL400 series may take a few seconds to power on fully and illuminate, please be patient when first turning on the light.



Users should not look directly into the light as it is bright and will illuminate when powering on.



Please check (when using the mobile version) that the power cable is without visible damage, harsh folds, knots or cuts in the rubberised coating.



If you are using a mobile version; check that the cable is fully connected to the device and that the plug is fully inserted into the power socket, when switching the power on.

2.3 Battery Back-up

The SL400 series has the capability of using a battery back-up system.

The battery should be conditioned before being used for the first time. Battery conditioning involves removing all the charge from the battery. Batteries should be conditioned regularly. Condition a battery when the device is stored for long periods, or when the charge becomes noticeably shorter.

Follow the steps below to condition a battery:

1. Disconnect the battery from the light.
2. Attach the battery in need of conditioning to a suitable electrical supply.
3. Charge the device uninterrupted for up to 10 hours.
4. Disconnect the electrical supply and re-attach the battery to the light, allow the light (while disconnected from its primary power source) to run on the battery until it shuts off.
5. Charge the battery until fully charged again.
6. The battery is now conditioned.





Batteries can deteriorate over time, meaning a reduction in their performance.

To check the performance of a battery, follow the steps below:

1. Charge the battery uninterrupted for 10 hours.
2. Disconnect the mains supply to the light and allow it to run on the battery until it shuts off.
3. The operating time of the light reflects the condition of the battery. Replace the battery if the operating time is significantly lower than the specified time.

2.4 Powering On & Variable Intensity

The SL400 Series uses a control panel system to control the lighting options of the lights; this system has 10 continuous steps to adjust light intensity from on-board memory through a control panel located on the arm of the lighthouse.

Button	Label	Operation
	Power Button	Powers the light ON or OFF
	Increase Intensity	Increases light intensity
	Decrease Intensity	Decreases light intensity
	MIS Mode	Switches light operation between MIS or surgical mode.
	Light Intensity Indicator	Indicates the level of light intensity

Ensure mains power is connected to the light and press the power button; this should then illuminate the light.

Use the controls on the display to increase or decrease light intensity (the intensity level is indicated through a line of LED indicators on the control panel).



The standard SL400 series uses a manual focus system for the light field which is controlled by a rotation system in the handle; rotate the handle to focus and concentrate the beam or to give a wider angle of illumination.

The SL400 system with camera uses an electronic focus system for the light patch; this is controlled by the 2 focus buttons shown on the control panel in the image above.

To power off the light after use, press the power button again.



Please Note, if the light is turned off at a dimmed level, it will remember that level the next time it is turned on, please check the luminance level shown on the control pad.

2.5 Adjusting the Lighthead

The SL400 Series lights are secured using a large white, tension balanced and adjustable arm. The head itself has forward and backward motion through the hinge joint behind the control panel on the tertiary arm.



Please be aware, the suspension arm is sent out adjusted to the horizontal plane, to adjust its minimum and maximum heights, please refer to the adjustments in section 4.5



The head can be adjusted through use of the rails, located on the side or with the handle in the centre of the head (this handle is also used to control the light patch size / focusing depth).



Care should be taken not to violently or forcibly adjust the head as this may damage the light.

2.6 System Mounted HD Camera



The SL400 series light system has the option of a HD zoom camera system with 20x auto-focus.

This allows the users to record and display their work on screen for teaching and assessment purposes, for an in-depth review of the Daray Medical camera, please contact Daray.

The camera user manual hosts details of the camera's key features, how to use and how to operate the camera; and also contains detailed data for the camera's electrical and technical schematics.

The camera lighting system has an additional 4 buttons on the standard control panel located on the arm. These buttons are used to control the magnification zoom of the camera and focusing of the light patch.



The top row are used to focus the light field patch while the lower 2 are used for controlling the zoom function of the camera as indicated.

3. Installation Guide Section

3.1 Considerations



The ceiling structure must be capable of handling up to a 500kg load.

The procedures below are detailed to a high level however *If in doubt please consult a qualified electrician.*

Minimum Room Requirements	The SL400 Series ceiling mounted light (single and double) has a standard fixing height of 3.0m . The design works off a fixed plate system and has a large vertical motion with a minimum fixing point of 2.7m .
Maximum Room Requirements	Please note, if the ceiling / fixing point of the light is above 3.1m then a customised ceiling mount will be required, (please contact Daray for more information). If a suspended ceiling is in the room, you will need to construct a platform down to the suspended ceiling height to allow the ceiling plate to be fitted at the required height.
Live Electric Circuitry	All personnel working around live circuitry should be qualified and following proper procedures
Heavy or Difficult fittings	Fitting the ceiling plate can be difficult and aspects of the fitting may require more than one person; this work should only be attempted by appropriate and competent personnel.
Existing Environmental Factors	When fitting, considerations have to be taken for existing services such as; fire alarms, vents, lights, etc. along with interior ceiling construction and any surrounding hazard.
Environmental Responsibility	Once our products are installed all packaging should be disposed of and recycled where appropriate, and in accordance with local governing regulations. The normal life span of the SL400 series is up to ten years. We recommend the equipment should be discarded and recycled when reaching the end of its life

These instructions are based on the assumption of a fresh fit into a room with no previous lighting structures. With installations onto sites with equipment already in place, we recommend that the previous lights' mounting plates be removed and the new ones fitted as if into a fresh fitting scenario.

3.2 Ceiling Mounted Lights

After confirming the structural stability of the fixing point it will be necessary to decide on the best course of action for installing the ceiling plate. There are various different methods for loading the plate onto the ceiling, on the following page are various example methods that can be used.



If there is any doubt it may be necessary to involve structural engineers to verify stability of ceiling construction and the most appropriate fixing method.

3.2.1 Attachment methods and void suspension

The ceiling mount can be split into 2 parts, an optional fixing plate and the ceiling plate. Please note, the recommended room height allowed for fixing requires the bottom of the ceiling plate to be no lower than 3m.

- **Bolted Directly into a structural slab and secured with chemical bonding**

This is our primary choice for mounting our lights to the ceiling structure, appropriate rawl bolts and chemical bonding should be used to secure the fitting.

- **Bolted to a Uni-strut Construct**

For certain ceilings we recommend fixing uni-strut to the ceiling first as we have found that this spreads the load easier and the fixings don't have to be exact if the reinforcing bar obstructs the fixing holes.

When using a uni-strut construct for mounting the ceiling plate, you should ensure that the uni-strut is cross braced to ensure it is secure and does not move.

- **Welded to structure**

When welding to the structure a fixing plate should be used as an intermediary component that would be welded to the structure; then the ceiling plate attached to that. Any welding must be capable of handling a 500Kg load.

- **System anchored to composite deck**

A customised composite deck could be used either in conjunction with or as a replacement to the fixing plate. Any substitute parts must meet safety standards and be assessed by a competent structural assessor. The composite deck is designed to spread the weight of the light over an enlarged area.

- **System bolted to structure**

This system requires prior planning during the base construction phase of the ceiling above, bolts should be fed through the metal ceiling prior to the concrete base being poured. These bolts should be based on the fixing plate layout in section 3.3.1

3.2.2 Bolting Advice

We cannot recommend the use of any specific bolts or bolting methods as these are entirely dependent on the composition of the ceiling structure. Different compositions will require different bolting types and lengths.



Please Note, individual structural observations must be considered when deciding on fixing bolts to be used. Fischer (<http://www.fischer.co.uk/>) provides a free advice line for fixings. We advise that any fixings should be capable of handling a 500Kg load; meet CE regulations for safety and be installed by qualified personnel.

3.3 Lighting configuration

Custom mounting aspects may be required dependent on the choice of attachment method, and whether the light is being attached in a void or directly onto an open surface ceiling.

Daray's standard mounting recommendation is to have the fixing plate directly bolted into the structure of an open surface ceiling when possible.

Ultimately the mounting method used is the responsibility of the project engineer or fitter. This includes the specification of attachment hardware, lateral bracing and the suitability of the surface to be fixed to.

3.3.1 Affixing the Ceiling plate

The location of the light should be decided by the end user / project manager or through schematical drawings. Once the location has been decided it will be necessary to first mark the location of the ceiling plate.

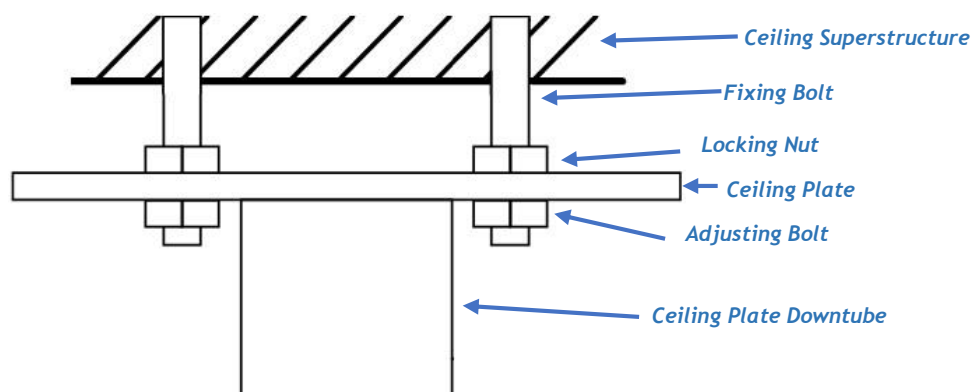

As shown, fixing the ceiling plate requires bolts be fitted directly into the ceiling super structure. The ceiling plate can however be fitted to an optional fixing plate instead. The fixing plate would then attach to the ceiling super structure instead of ceiling plate.

Whichever fixing method used; it is highly advisable that the plate being fixed to the ceiling, is secured with a minimum of 4 bolting points to ensure a complete and sturdy fit.

Once the fixing bolt points are fitted and secured, you will need to attach a locking nut to each bolt before attaching the ceiling plate. Now fit the ceiling plate to the fixing points by sliding the bolts through the selected inner or outer ring of fixing point holes on the ceiling plate and attach a 2nd nut to the fixing bolts.

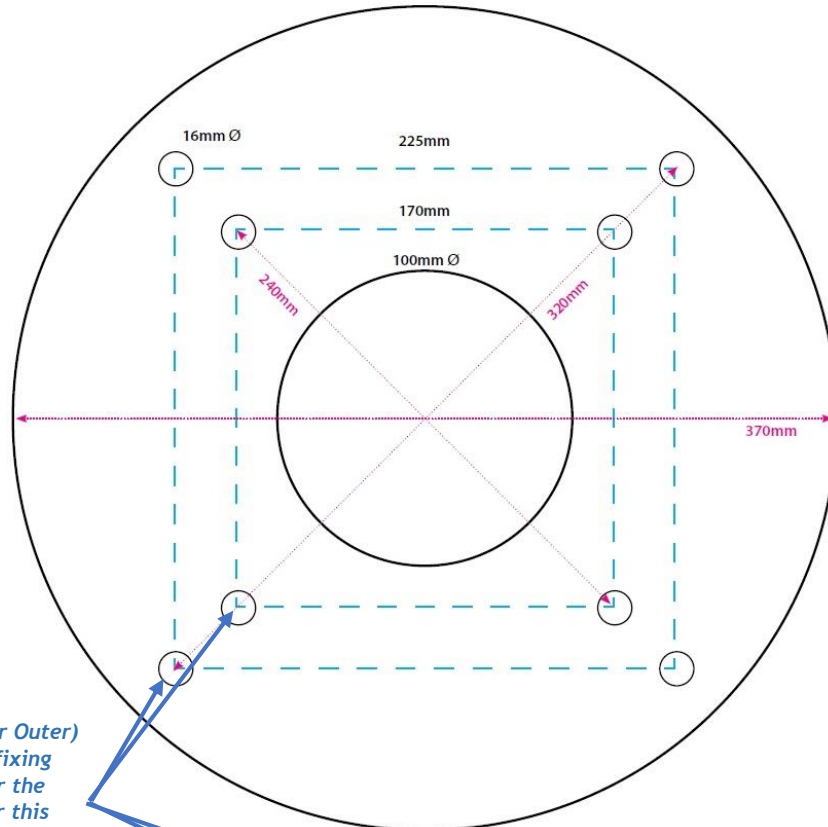

*Fixing Points (Inner or Outer)
(Please note, the 4th fixing point is located under the transformer, however this can easily be removed during plate fixing)*



Ceiling Plate

Tension Controls
(second on opposite side)

Once the ceiling plate has been fitted, it will be necessary to ensure that it is balanced on the vertical plane. This can be achieved by adjusting the level of the nuts used to secure the plate onto the fixing bolts. Once this adjustment has been done tighten the locking nuts down to the ceiling plate to lock the plate into position.

After any adjustment it will be necessary to check that all fixings are still sound and that locking nuts are tight.

3.3.2 Fixing the arms and main installation

The downtube cannot be adjusted as this is a fixed part of the ceiling mount; the primary rotation arm(s) come pre-attached to the arm boss which is then inserted into the ceiling mount downtube, any customisations to the length of these parts will need to be done by Daray.

Before attaching the arm(s) boss to the downtube; the ceiling mount must be absolutely true on the vertical plane.

Once the parts are ready to be attached it will require 2 or more people to fit, as the cables from the arms need to be fed up through the ceiling plate and through a hole located in the downtube, at the same time as the arm boss and rotation arms are attached. The hole is located behind the central fuse block (indicated on the image below). Using some form of guidance wire secured to the cables may make this easier to install correctly.

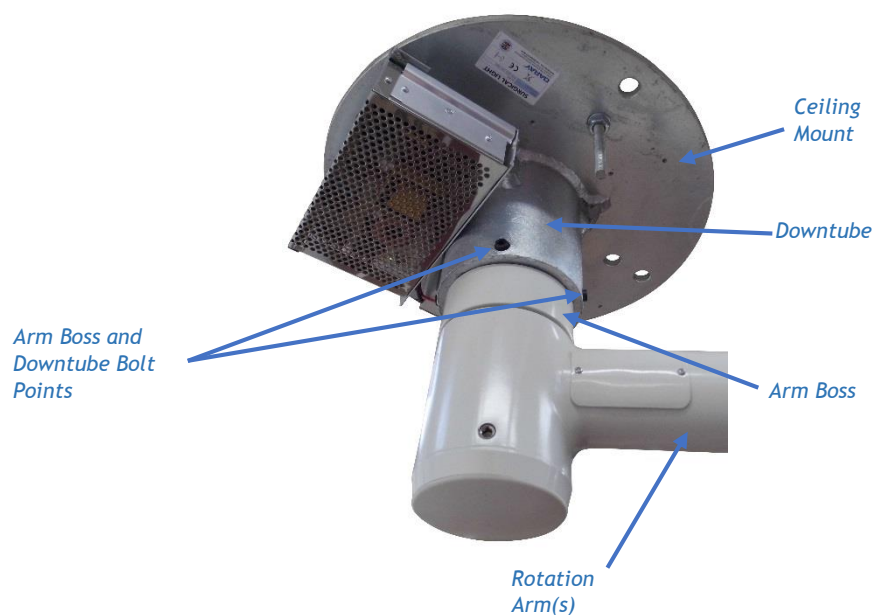
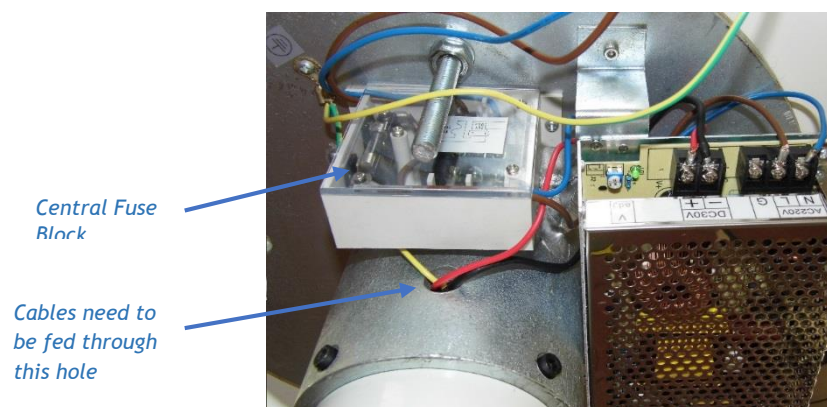

To secure the arm system into the downtube you will need to lock the arm boss into the downtube with the 4 bolt points located equally around the downtube as indicated.

Before progressing onto fixing any other arms, ensure that the arm boss is attached securely.

For the standard single headed SL400's the suspension arm comes pre-attached to the rotation arm. To attach a suspension arm to the rotation arm you will need to unscrew the locking screw from the rotation arm and ensure the plug area inside the arm is clear. If there is a black cap inside the rotation arm socket protecting the plug, this should be removed, then make sure the washer ring is in place on the balanced suspension arm.

For the standard version of these lights no wiring is required for the inside of the arm sections. The connections are made using a fixed spigot male - female plug system. Grease outer section of the spigot (not the plug) and slide the suspension arm's spigot up into the rotation arm joint taking care not to damage the plugs. Lock in place with the locking screw previously removed.

For the Camera lighting system, DC Molex connections are used along with mini coaxial connections in the joints of the arm system, due to this the arms have restricted movement in order to protect the internal wiring.

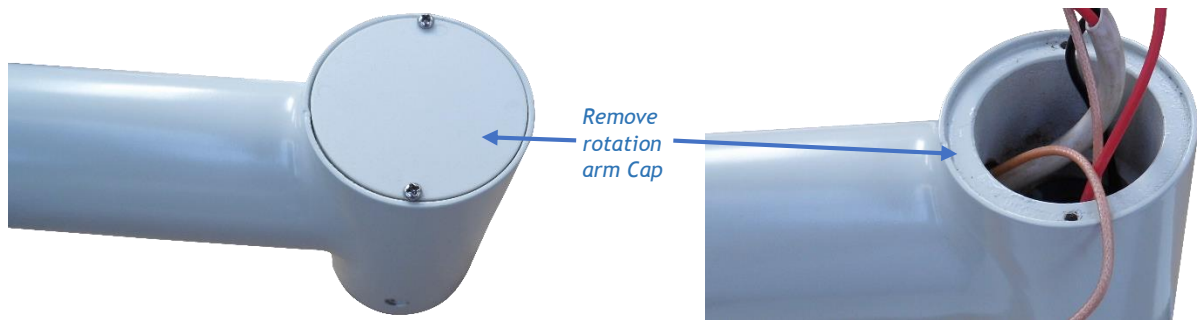

For the Camera System, Remove the top cap of the rotation arm and take the cables out, then take the suspension arm and feed the cables from the top of that arm, through the hole of the rotation arm socket. Grease outer section of the spigot (not the plug), line up the holes as indicated below and push the spigot up into the rotation arm. Insert the locking screw (indicated) to secure the arm in place, now connect the DC Molex connections and the coaxial connections. Push the cabling back into the arm and re-attach the cap on top.

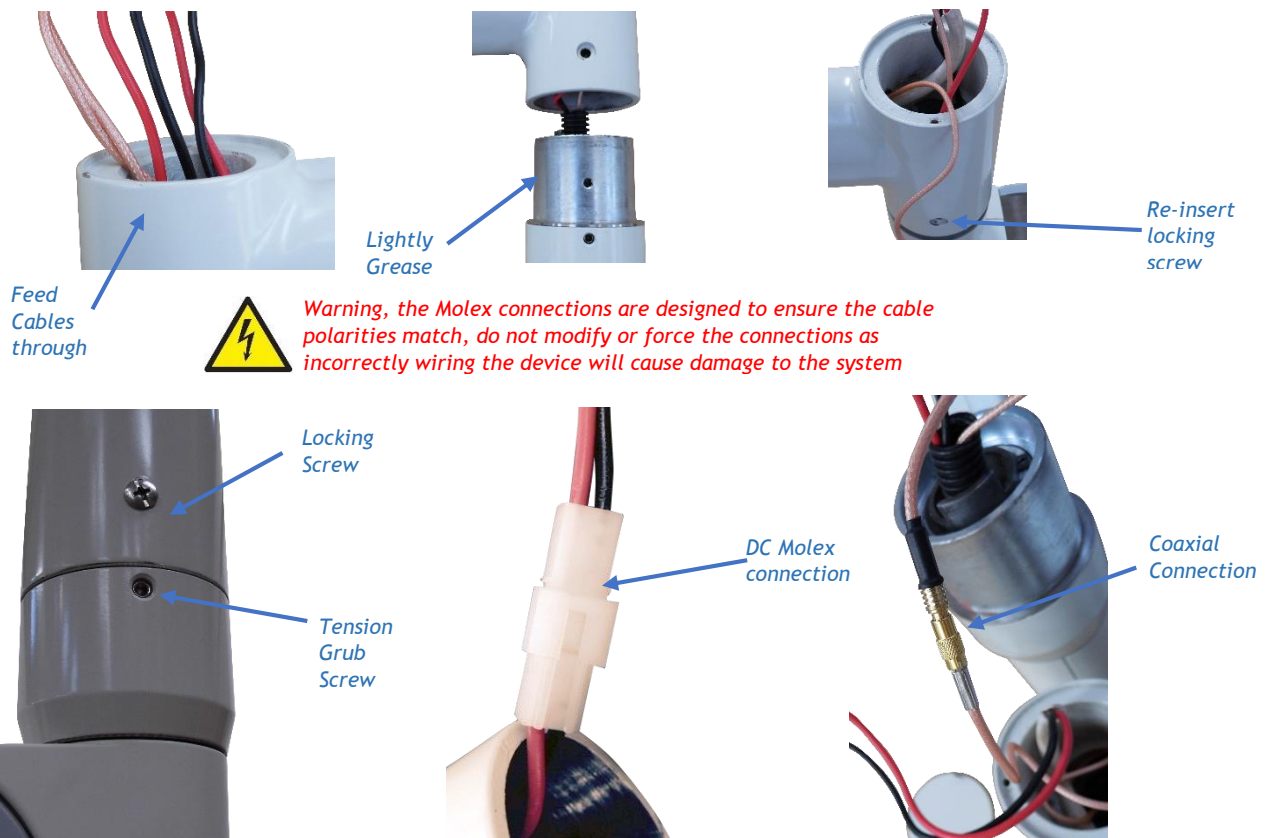

The lighthouse is connected to a third arm system; to connect this arm section to the suspension arms first remove the screw shown below, this will allow the sliding cover to move, lift this cover up and it will reveal a locking clip round the back, remove this to allow you to attach the lighthouse arm.

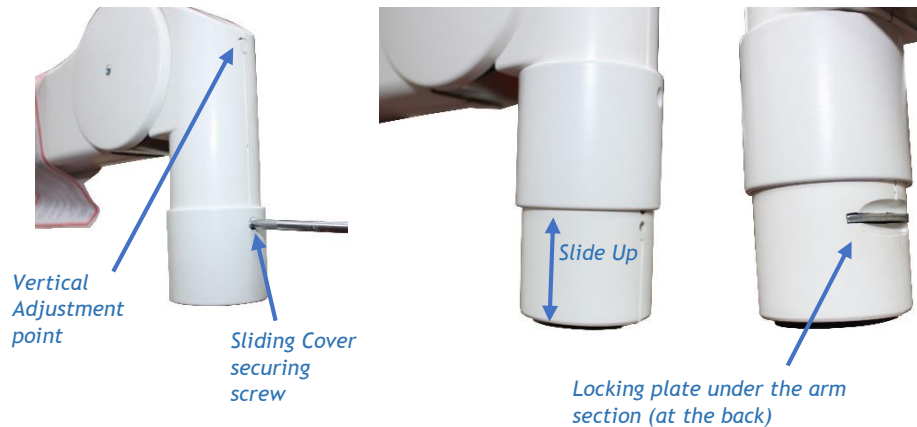

The standard system follows the same structure as the previous arm connection. No wiring is required for the inside of the arm sections, the connections are made using a powered spigot plug system. Grease the lower section of the spigot (not the plug) and slide the lighthouse arm's spigot up into the rotation arm joint then re-insert the locking plate, slide the cover back down then re-secure it in place with the original screw.

For the Camera system you will have a DC Molex Connection and Coaxial cable. These need to be connected then fed into the spigot of the lighthouse (pictured below) push the arms together carefully, whilst making sure not to trap any cables. Re-insert the locking plate, slide the cover back down then re-secure it in place with the original screw.

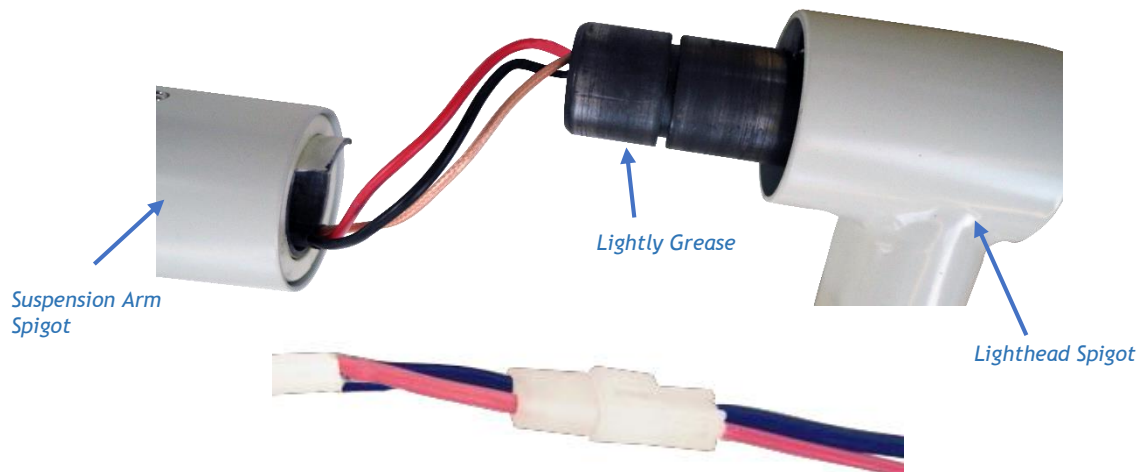

Warning, the Molex connections are designed to ensure the cable polarities match, do not modify or force the connections as incorrectly wiring the device will cause damage to the system



Please be aware, the suspension arm may not initially have access to its entire range of movement, the arm is sent out adjusted to the horizontal plane, to increase the arms vertical movement you will need to insert a hex key into the end of the suspension arm and turn the key. For detailed instructions, please refer to the adjustments in section 4.5 of this manual.



3.3.3 Wiring and transformer layout



Before working on any electrical connections please make sure that the power to the light is switched off at the source and secured so that it will not be turned on during installation.



The mains power supply should meet IEC60245-1 requirements and should be fitted on an Independent fixed master switch. (The switch should meet IEC328 requirements and the directional movement parts of the switch should meet IEC447 requirements and the symbols should meet IEC60601-1 requirements.)

Ideally the cable used to power the light should be of a 1.5mm twin and earth type; however, this is dependent on, and subject to individual country and government regulations. Daray recommends that the power supplied uses an earthed switched fused spur, protected with a 3 amp fuse.



Ultimately, the type of cabling used is the responsibility of the installer and should comply with any local governing bodies and regulations.

The wiring should be as follows:	
Live terminal	→ brown wire.
Neutral terminal	→ blue wire.
Earth terminal	→ green/yellow wire.

The above wiring is for modern wiring applications (post 2000). On completion of the wiring, the next stage will be attaching the suspension arms to the ceiling mount.

Wiring between the single mounted and double mounted versions may differ slightly, please follow these wiring instructions carefully.

Double Ceiling Mounted Lights

Before any cabling can be done you will need to make sure all cables have been fed up through the ceiling plate and through a hole located in the downtube, this is located behind the central fuse block (indicated on the image below) feeding these cables through will need to be done while the arm boss is being mounted at the same time. Using some form of guidance wire secured to the cables may make this easier to install correctly.



Fitting the arm boss can be difficult and aspects of the fitting may require more than one person; this work should only be attempted by appropriate and competent personnel.

The cables leading to the transformer from the central fuse block are pre-installed. This transformer is used to power the lighthouse(s). The black and red DC lines that are fed through the hole will need to be connected to the relevant points on the transformer with their bullet connections.



Warning, please observe the Cable Polarities and ensure that they match, the red DC cable is + and the black DC cable is - incorrectly wiring the device will cause damage to the system

There are 3 wires per lighthouse that should be threaded through the hole. All earth lines will need to be grounded and attached directly to the ceiling plate at the designated location **before any power is supplied to the device.**

The grounding point is signified by the symbol -



Earth Line

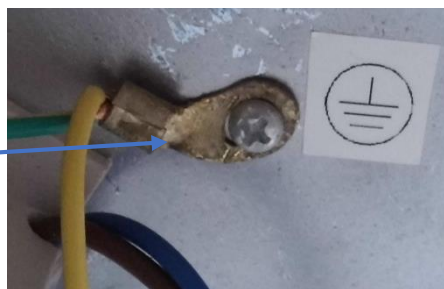

3.3.4 Attaching the Ceiling Cover

The last aspect of fitting is to attach the ceiling mount cover, this should be done after all the wiring has been checked and the device turns on.

The primary cover is split into 2 halves. You will need to place the two halves over the ceiling mount and secure them together using the screws provided.

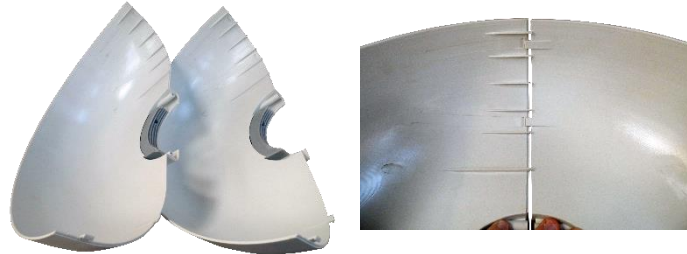

Once the two halves of the primary cover are connected, work the cover over the cabling and then screw tight to lock the ceiling mount cover in place.



If the head is drifting, or if the movement of the arm is stiff or not what you expect, use a hex tool as indicated in section 4.5 of this manual to adjust the arms.

The light can now be tested by applying power and pressing the power button on the control panel. Check the arm and head for smooth and correct movement. Your new Daray light is now ready for use.

To gain the full support of our warranty, please fill in our warranty web form or contact Daray by phone or email.



Daray also provide service plans to help you maintain your light.
Contact Daray on **0800 878 9864** for more details.

3.4 Wall Mounted Bracket Assembly



It is vital that the wall mount bracket is true on the vertical plane as if not, this will cause the light to drift.

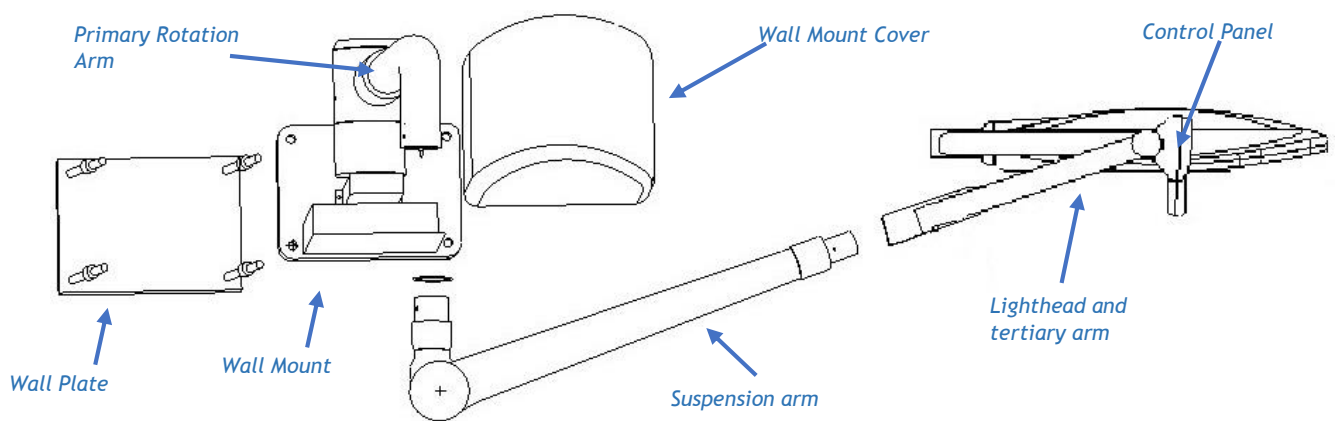

3.4.1 Considerations

The structure and fixings must be capable of handling excessive torsional loads up to 500kg.

Wall Construction	Before fixing it is important to consider the strength of the wall and the depth of the fixings used. Use of a building engineer or structural drawings may be required to decide on suitability.
Product weight	Note, the wall mount and the rest of the light are heavy. Fixing the Wall bracket may be difficult and require 2 persons to install correctly. We advise that only professional or competent people fit these lights.
Product Wiring	The mains power supply should meet IEC60245-1 requirements and should be fitted with a fixed master switch.

3.4.2 Bolting Advice

We cannot recommend the use of any specific bolts or bolting methods as these are entirely dependent on the composition of the building structure. Different compositions will require different bolting types and lengths.



Please Note, individual structural observations must be considered when deciding on fixing bolts to be used. Fischer (<http://www.fischer.co.uk/>) provide a free advice line for fixings. We advise that any fixings should be capable of handling a 500Kg load; meet CE regulations for safety and be installed by qualified personnel.



Ultimately the fitting of the light is the responsibility of the project engineer or fitter. This includes the specification of attachment hardware, lateral bracing and the suitability of the surface to be fixed to.

3.4.3 Placement and Installation

The wall mounted SL400 comes with a wall plate for mounting the light appropriately to a weight supporting wall of your buildings superstructure.

Please be aware that the wall mount and the primary rotation arm come pre-attached to each other. To fit this system you will likely require a minimum of 2 fitters to correctly support and attach the wall plate and arm safely and securely.

The wall mount needs to be completely true and horizontally/vertically aligned when fixing. We recommend initially placing the mount against the wall, aligning it and then indicating on the wall where the relevant fixing points are to be located. Drill the holes for the fixing points; before attaching the wall mount please ensure that there are a set of adjustment nuts attached to the bolts (these are for adjusting vertical alignment once the wall mount is attached), then attach the mount whilst checking the vertical alignment as necessary.



Secure the mount onto the wall using a second set of nuts (the fixings nuts). Once the mount has been fixed to the wall make any adjustments needed to the alignment, then tighten the adjustment bolts and the fixing bolts towards the mount to lock the plate in place.

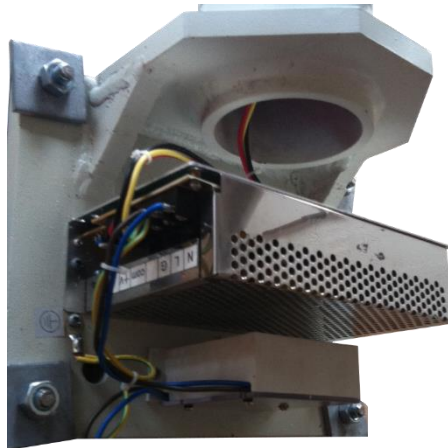

The SL400 Series lights should be connected to the mains supply via the transformer (pictured above). The cable used to power the light should be of a 1.5mm twin and earth type. Daray recommends that the power supply uses an earthed switched fused spur, protected with a 3 amp fuse.

The wiring should be as follows:		
Live terminal	→	brown wire.
Neutral terminal	→	blue wire.
Earth terminal	→	green/yellow wire.

The above wiring is for modern wiring applications (post 2000).



The mains power supply should meet IEC60245-1 requirements and should be fitted with a fixed master switch. All components should meet relevant IEC328, IEC447 or IEC60601-1 requirements.)



Please note, under no circumstances should you circumvent the transformer and connect this light directly to the Mains electrical supply.



Before working on electrical connections please make sure that the power to the light is switched off at the source and secured so that it will not be turned on during your work.

The wiring for the Wall Mounted edition of the SL400 series is pictured below, please note, this system uses a self-contained fuse block system located under the transformer.

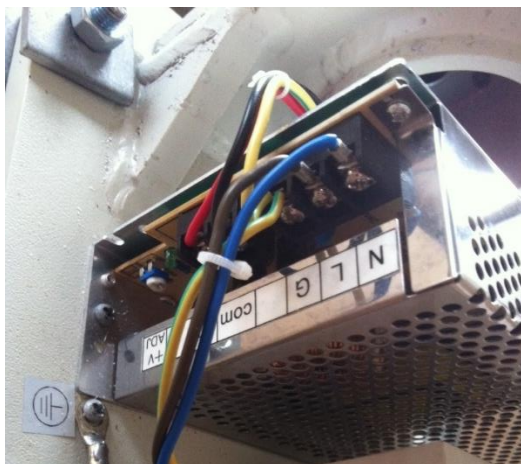

To attach a suspension arm to the rotation arm for the wall mounted system you will need to unscrew the locking screw from the rotation arm and ensure the plug is clear. If there is a black cap inside the rotation arm socket protecting the plug, this should be removed, then make sure the washer ring is in place on the balanced arm.

No wiring is required for the inside of the arm sections, the connections are made using a standard male - female plug system. Grease the spigot and slide the balance arm's spigot up into the rotation arm joint and lock in place with the screw provided.

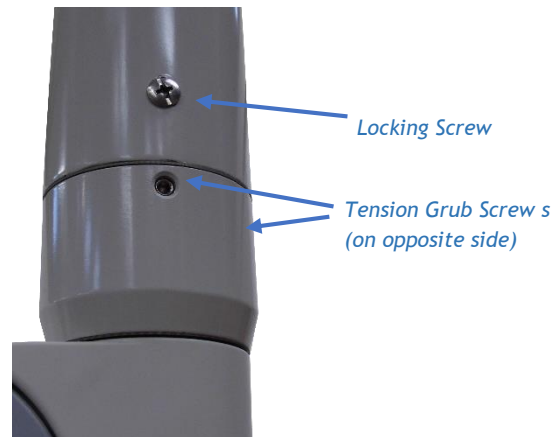

The lighthouse is attached to a third arm system which incorporates the lights control panel. This arm also uses a plug system and can be connected straight to the suspension arm; remove the locking screw, ensure that the washer ring is placed on the spigot, grease the spigot and plug the arm in. Secure the arm with the locking screw and your lighthouse is now attached.



The light can now be tested by applying power and pressing the switch on the control panel.

Check arm and head for smooth and correct movement. If the head is drifting, or if the movement of the arm is stiff or not what you expect, use a hex tool as indicated in section 4.5 of this manual to adjust the arms. Your new Daray light is now ready for use.

To gain the full support of our warranty, please fill in our warranty web form or contact Daray by phone or email.



Daray can also provide service plans to help you maintain your light. Contact Daray on **0800 878 9864** for more details.

3.5 Mobile Mount Assembly

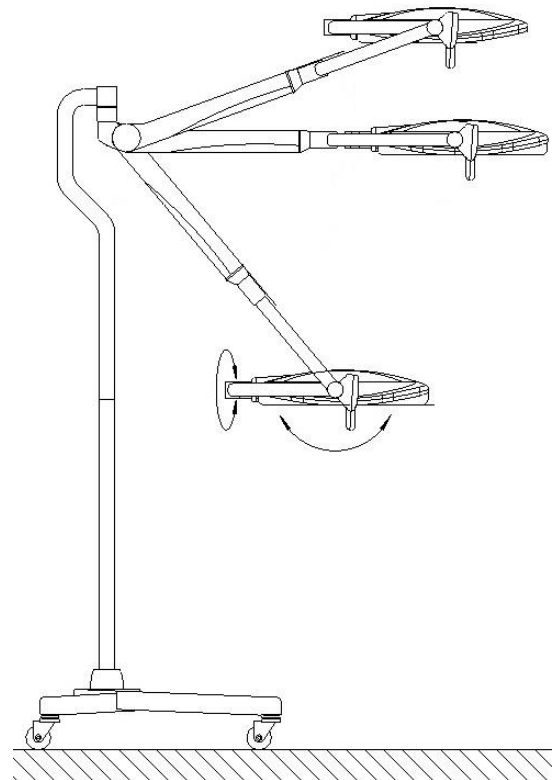

<p>Product weight</p>	<p>Note, the mount and the rest of the light are heavy. Constructing the light may be difficult and require 2 persons to install correctly. We advise that only professional or competent people fit these lights.</p>
<p>Product Wiring</p>	<p>The mobile version of the SL400 uses an IEC plug connection however the mains power supply should meet IEC60245-1 requirements and should be fitted with a fixed master switch.</p>

For the mobile assembly, the base should already have all casters in place, however if for some reason they are not, they can simply be pushed into the base and at the correct point they should click and lock in.

Making sure all the wheels are in place, set the base down facing up and lock the brakes on the casters: This will avoid movement during assembly.



Once the base is locked, you will need to attach the first section of the vertical tubing; remove the cap of the mobile base and align the bolt points of the tubing to the base. You will need to feed the wiring from the base up through the first section of tubing. Secure the wire and then fix the tube in place using the bolts provided then slide the cap down over the tubing.

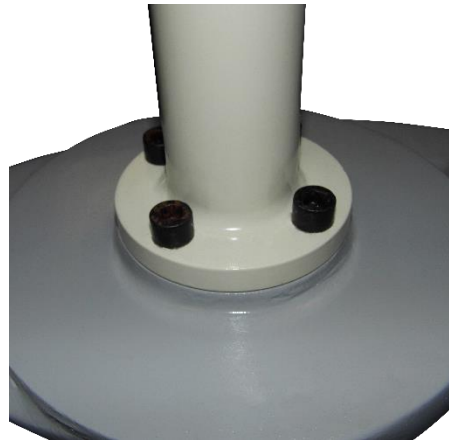

With the first section secured, you will need to attach the second section of the vertical tubing. You will need to unscrew the locking screw from the tubing section and ensure the tube is clear. Make sure the washer ring is in place on the first section of the vertical tubing and connect the wires from the upper section to the wires coming through the lower tube section. Once attached you will need to insert the two securing bolts shown.

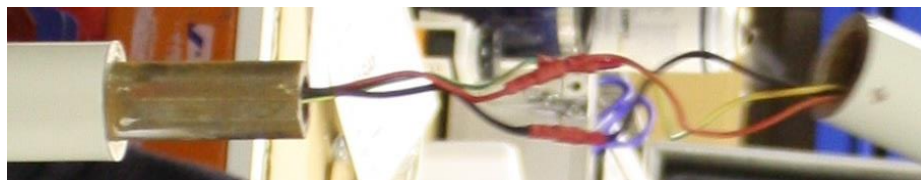

Warning, please observe the Cable Polarities and ensure that they match. Incorrectly wiring the device will cause damage to the system

Securing Bolts

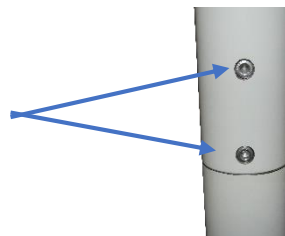

Now that the vertical tubing and mobile base are fixed you will need to attach the balanced suspension arm. There is no rotation arm with the mobile mounted version of the SL400 series light.

To attach the suspension arm you will need to unscrew the locking screw from the tubing section and ensure the plug is clear. Again, if there is a black cap inside the socket protecting the plug, this should be removed, then make sure the washer ring is in place on the spigot of the suspension arm. Grease the spigot and insert the arm into the socket. Once attached you will need to secure the arm with the screw previously removed.



The lighthead is attached to another arm system which incorporates the lights control panel. This arm also uses a plug system and can be connected straight to the suspension arm; remove the locking screw, ensure that the washer ring is placed on the spigot, grease the spigot and plug the arm in. Secure the arm with the locking screw and your lighthead is now attached.



Insert the power cable into the base and check that all the lights are illuminated. The main power button is located on the mobile base.



Check arm and head for smooth and correct movement. If the head is drifting, or if the movement of the arm is stiff or not what you expect, use a hex tool as indicated in section 4.5 of this manual to adjust the arms. Your new Daray light is now ready for use.

To gain the full support of our warranty, please fill in the warranty card at the back of this brochure.



Daray also provide service plans to help you maintain your light. Contact Daray on **0800 878 9864** for more details.

NOTE: The mains power supply should meet IEC60245-1 requirements

4. Maintenance

The proposed maintenance is only a suggestion. Depending on the use of the product and the operating environment, this may need to be revised more often. Daray would strongly recommend against “quick fixes” with tape, etc. If you cannot resolve a problem then please contact our helpline on **0800 878 9864** or email **support@daray.co.uk**

4.1 Maintenance schedule

Weekly checks should include:-	Range of movement testing, the lighthouse should be light and easy to move throughout the range
	No visible signs of excessive wear.
Monthly checks to include:-	Check the downtube and thumb screws for wear and report as necessary
Six monthly checks to include:-	Remove head and clean the interior of the hinge
	Remove arm, clean spigot and re-grease as necessary.
	Check all electrical connections are sound and that there is no visible cable wear.
	All fixings to be checked and be of sound construction.

4.2 Safety Precautions

- For all cleaning work, power off the equipment and where possible completely power off any mains connection, only minimal cleaning fluids should be used.
- Please do not look directly into the light source when illuminated.
- If the equipment is dented or scratched this should not impact the usability of our lights however we advise that you do not attempt to cover over any damage as this will impact upon the effectiveness of any cleaning you do. Simply use an alcohol based cleaning spray when cleaning and pay special attention to any damaged areas.



(When applicable) If there is damage to the power cable or if exposed wire is visible **DO NOT USE**



The SL400 series light is to be disassembled and maintained only by a qualified technician.

4.3 Cleaning



Do not use strong chemical cleaning agents or any abrasive materials to clean the light. The light is not waterproof so the use of excessive amounts of cleaning fluids could cause serious harm or injury.

The SL400 Series lights are fully enclosed heads with an Ingress Protection (IP) rating of 54.

We advise that the light should only be dusted with a soft flannel cloth, and the front cover gently cleaned with an alcohol-based liquid (aerosol) spray, then wiped dry.

4.4 Fuses and their replacement

The SL400 series uses a transformer to control the power to the lighthouse(s). On the ceiling mounted systems the transformer is wired into a sealed fuse block, the fuse can be replaced. However, please ensure there is no power to the device when changing any fuses.



The system itself should be fitted into the mains via an earthed, switched fused spur.

We recommend a minimum supply fuse of 3 Amp's however this will be affected by, and be dependent upon, individual circumstances such as differing power systems used per country.

For the Mobile mounted SL400 series lights, the fuses are located on the rear of the base, near the IEC inlet as pictured below.

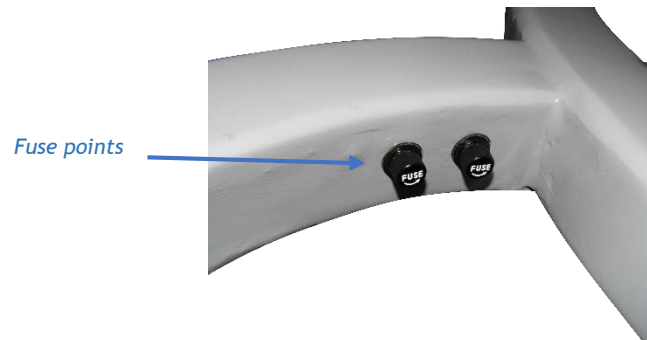

The wall mounted version of the light has a similar design to the ceiling mounted lights, there is a transformer fitted to the base of the wall mount and a dedicated fuse block just under that (pictured below).

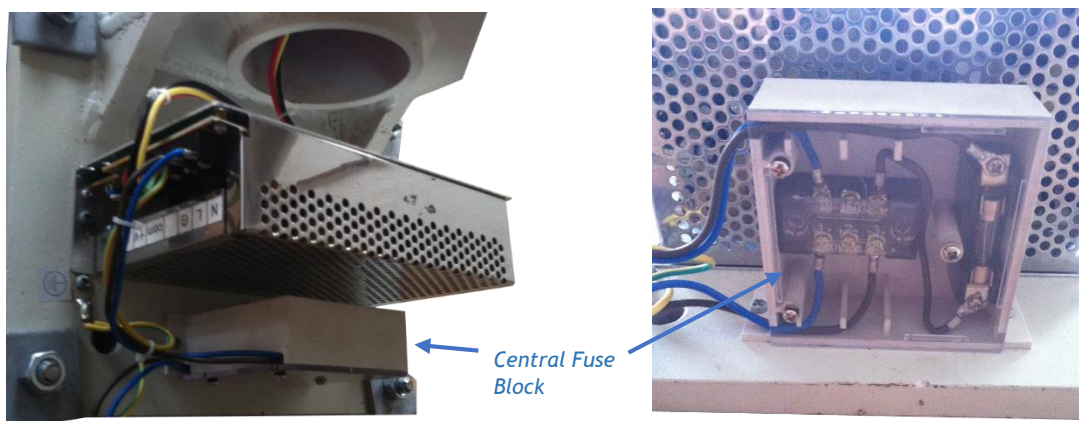

The SL400 Series comes with a few spare fuses. For any internal transformer burnout's please contact Daray.

4.5 Adjustments

Rotation arm

If the Rotation arm's start to drift then the ceiling mount system may have become uneven; to correct this issue you will need to adjust the relevant nuts on the ceiling mount, these are indicated in section 3.3.1 of the installation section in this user manual. The suspension arms can also have their tension adjusted by using a hex tool on one grub screw per arm; found on the central arm boss joint for each arm.



Suspension arm

The suspension arms have 2 methods of adjustment. The horizontal drift (left and right) movement is controlled by a pair of grub screw sockets opposite each other, located at the connection point between the rotation arm and the suspension arm (note, both sides need to be tightened equally for the tension control to work effectively).

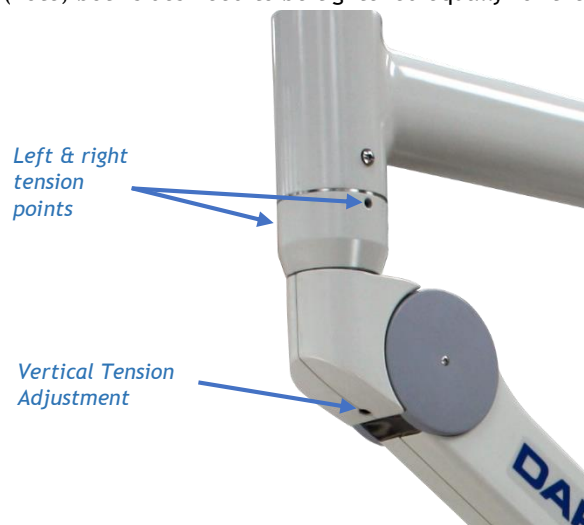

The 2nd adjustment is a control for the vertical tension (upward and downward) of the arm. This is controlled by a small keyhole socket at the bottom of the arm where the suspension connects with the rotation arm, this can be seen as indicated in the image above.

Suspension Arm Height

The suspension arm is sent out adjusted to have little range of vertical motion, this makes it easier to protect the arm during transit and storage. This vertical movement of the arm can be adjusted through a hex point screw in the end of the arm covered with a spring closed door on the front (indicated below). Insert a hex tool into this hole to adjust the arms range of movement. Once the full light is installed you may use this adjustment to raise the highest point of the light up to wherever you desire (such as bringing the top of the arm up to a suspended ceiling).



Once you feel you have the right tension and movement within the arm, you should be able to place the light at its highest and lowest points with little to no motion.

Lighthouse hinge arm

The lighthouse's are on a separate arm section, movement of this arm is adjusted via a grub screw located on the hinge behind the control panel on arm, this can be adjusted using a hex tool.



Warning! These arms are under spring tension, as such do not try and adjust the internal mechanics of the arms. This can only be done at a Daray authorised service centre.

The lighthead itself has one final tension point, this is located at the base of the head where it attaches to the tertiary arm system, and this can be seen pictured below.



Wall and Mobile Mounted arm adjustments

The wall mounted and mobile mounted versions of the SL400 series uses slightly different adjustment points, primarily through tension grub screws.

The wall mounted system uses a rotation arm and suspension arm system similar to the ceiling mounted version of the SL400 and is adjusted in the same manner, it also uses an arm boss similar to the ceiling version just reversed. The adjustment screw is located at the top of the arm boss instead of at the bottom.



The main difference in arm configuration for the wall mounted system is where the suspension arm attaches to the tertiary arm of the lighthead. This follows the same trend as the mobile system as pictured below. The movement in this joint is locked and should not move.

The joint for the mobile mount, where the suspension arm attaches to the vertical tubing is controlled using another grub screw system as indicated.



4.5.1 Replacing the LED Bulbs

The LED bulbs in the SL400 series are high quality and should not need to be replaced in the lifetime of the light, however if any bulbs do need to be replaced, please consult a qualified electrician or contact a Daray authorised service centre as replacing these bulbs will require access to the internal body of the lighthead.

5. Troubleshooting Guide

Problem	Possible Cause	Corrective Actions
No light output	Power Supply	Please check to see if the front control panel illuminates when pressed, if not check that the power switch is switched to supply power to the device, if this does not work, please consult your on-site maintenance or a qualified electrician
	On/Off/Intensity	Press the controls on the panel for the light to check if the light will increase in intensity (if dimmed refer to poor light output actions).
	Fuses	Visually check fuses then check continuity with meter if fuse errors persist
	Faulty circuit board or a damaged transformer	In either situation we advise you contact us to discuss identifying specific internal errors and repairs.
	Damaged LED's	we advise you contact us or your supplier to discuss repair options
Poor Light output	Variable Intensity	Please check the variable intensity is not set to its minimum. To do this locate the control panel and press the sun symbol with multiple rays coming out of it. This is the control used to adjust the intensity.
	Voltage in	Verify that the correct mains voltage and correct transformer is being used.
	Voltage out	Verify correct secondary voltage for the lighthouse's under load, please contact daray to confirm the reading received.
Light patch not focused	Loose focusing device	<p>Please remove and replace the autoclavable handle located in the centre of the light as this may have been placed on incorrectly.</p> <p>Now attempt to adjust the light patch by using the central head handle.</p> <p>In the unlikely event that this does not resolve the issue, please contact Daray as the focusing control may be damaged.</p>
Lighthouse or Arm drift	Mounting bracket or downtube	Please check the vertical alignment of the downtube, if this is not aligned please contact the original fitter or a qualified specialist who can adjust the bolts in the mounting plate to straighten the light. If the arms continue to drift please refer to the adjustment section 4.5 of this user manual.
Lighthouse drooping or raising	Fatigue, or over tension, in the suspension arm	<p>The suspension arm(s) that the lighthouse(s) is attached to are spring tension balanced, there are adjustment controls for these shown in section 4.5.</p> <p>If the light is drooping then the spring needs tightening, However, if the lighthouse is rising then the spring is too tight.</p> <p>After initial adjustments please check the lights full range of vertical motion for drooping or over tension (move the head to its highest and lowest points and check for arbitrary movement).</p>

6. Warranty Information

6.1 Returns Policy

IMPORTANT!
Please fill out your warranty registration online at
www.daray.co.uk/warranty or contact Daray by phone (0800 878 9864)
or email support@daray.co.uk



DARAY's standard warranty is 12 months. However, this period may be extended for most lighting products up to 3 years* free of charge by completing and submitting the warranty registration. This warranty extension excludes any camera system. The camera system is subject to the standard 12 month warranty.

Year 1:	Warranty includes parts and labour (Return to Base)	*UK only
Year 2-3:	Parts only	

We want you to be completely satisfied with your purchase. If you need to return goods purchased from DARAY Ltd, please read the following information carefully.

The DARAY Ltd returns policy provides guidance on when you can return goods we have supplied, and what you can expect from us once you do. To see our detailed returns policy and procedure visit www.daray.co.uk/returns

TYPE OF RETURN	REMEDY
DAMAGED GOODS Goods which are physically damaged on delivery	We must be notified within 24 hours of receipt.
Dead On Arrival (DOA) Goods which do not work	Goods which do not work on arrival or develop a fault within 28 days, we will advance replace the item.
GOODS DEVELOPING A FAULT Goods which have developed a fault within the warranty period.	If the fault develops after 28 days, but within the warranty period, we will initiate the returns procedure.
NON WARRANTY Goods which have developed a fault outside the warranty period.	If a fault develops outside the warranty period, we will initiate the returns procedure charges may be applicable.
OTHER Any situation which is not covered by any of the above.	We will always try to help, but we cannot normally offer a refund.

For additional clarification, please refer to our terms and conditions at www.daray.co.uk/terms.

In a small number of cases, we may determine that a replacement would not work any better than the original product we supplied. In such cases we will only offer a refund rather than a replacement for qualifying returns. Replacement bulbs and spare parts ordered on our website or from supplied part codes are not eligible for credit. We will accept returns and exchange for the correct item.

If your purchase an item incorrectly you can return it within 14 days and it can be exchanged for another product of equal or higher value, excluding transportation charges incurred. Goods and packaging must be returned in their original condition. Under no circumstances will goods be accepted for return if they are damaged, have been subjected to improper handling or abuse or have been used.

If you send us goods that do not qualify for return, you will invalidate your claim to any refund, and you will be obliged to compensate DARAY Ltd for the cost of return postage and any other reasonable costs incurred processing the goods.

Your statutory rights are not affected.

6.2 Warranty Details

TERMS AND CONDITIONS OF WARRANTY

1. To qualify for this warranty you must register on www.daray.co.uk or return to Daray Ltd (Daray) the duly completed warranty-registration form accompanying the product.
2. Daray warrants this product (excluding lamp) against faulty material and workmanship during the period of the warranty. The period of warranty is the period stated on your warranty card and commences on the date of purchase of the product. In the event that the product is not in good working order Daray will provide, during the warranty period, a free repair service within the United Kingdom. The warranty is subject to proof of purchase being provided; therefore, you should retain your original receipt.
 - 2.1 The repair service consists of the provision of spare parts and/or replacement products (at Daray's discretion) which will be provided on an exchange basis and will either be new, equivalent to new or reconditioned. All replaced spare parts and products shall become the property of Daray.
 - 2.2 Daray's only obligation under this warranty is the provision of the service as set out above.
 - 2.3 All products are returned to Daray at the customer's cost and risk. Products to be returned should be adequately packed. For the address to send returns to please visit www.daray.co.uk
3. Daray's arrangements for providing service provided under this warranty may include the use of sub-contractors.
4. This warranty does not cover damage or defects in the Product caused by or resulting from:
 - Wilful neglect or negligence by anyone other than Daray;
 - Improper use, storage or handling of the product;
 - Use of non-Daray approved parts (such as replacement lamps) not compatible with the Product;
 - Fire, accident or disaster;
 - Use of non-Daray modifications other than in accordance with Daray's instructions;Attachment of fittings and accessories not approved by Daray;
Repairs, modifications carried out by service personnel not approved by Daray;
 - Damage caused by chemical corrosion from cleaning agents not approved by Daray.
 - Failure to use or install the product in accordance with the manufacturer's instructions.
5. Nothing in this warranty shall have the effect of restricting or excluding the liability of Daray in respect of:
 - a) Death and personal injury caused by the negligence of Daray, or for fraud;
 - b) Under the *Consumer Protection Act 1987* to a person who has suffered damage caused by a defective product or to a dependant or relative of such a person;
 - c) Direct damage to your property caused by the proven negligence of Daray.
6. This agreement does not give any rights other than those expressly set out above and in particular, Daray will not be responsible for any loss of income, profits or contracts or any direct or indirect consequential loss, damage caused to or suffered by the purchaser as a direct result of this agreement.
7. This warranty is offered (subject to these terms and conditions) in addition to, and does not affect your statutory rights.
8. Daray may disclose your details and other personal information to companies within the Daray group including any subsidiary company or sub-contractor of Daray for the purposes of performing our obligations hereunder.
9. You must not resell outside the UK any products supplied by Daray and covered by the *Export of Goods (Control) Order 1992* (or any law that replaces it) without obtaining all necessary licences. You also agree not to sell the product in the UK if you know or think that the person buying the product intends to export it without getting the necessary licences. You agree to impose similar conditions to these on anyone you sell the product to.
10. These conditions shall in all respect be governed and construed in accordance with English law and the exclusive jurisdiction of the English courts.

Product:

Serial No:

--

