

REMstar® | pro 2 with C-Flex™

CPAP System







User Manual



Table of Contents

Symbol Key	2
Intended Use & Contraindications	3
Specifications	4
Warnings & Cautions	5
System Features	7
First Time Setup	8
○ Installing the Filter	9
○ Device Settings	10
○ Assembling the Circuit	14
Accessories	15
○ Adding a Humidifier	15
○ Adding Oxygen to the System	15
○ Using DC Power with the System	15
Routine Use	16
○ Connecting the Circuit	16
○ Adjusting the Circuit	16
○ Ramp Button	17
○ Turning the System Off	17
○ Helpful Hints	17
○ Taking the FOSQ Test	18
Routine Maintenance	19
○ Cleaning the Filter	19
○ Cleaning the System	19
○ Reordering	20
○ Service	20
Traveling with the System	20
Troubleshooting	21
EMC Requirements	23
Warranty	27

Symbols

	Attention, consult accompanying documents
	AC Power
	DC Power
	Type BF Applied Part
	Class II (Double Insulated)
IPX0	Ordinary Equipment Rating
	Notified Body Approval for Standards Compliance
	Canadian/US Certification

REMstar Pro 2 with C-Flex CPAP system is the subject of U.S. patent #5239995 and #6105575. Other patents pending.

REMstar, Whisper Swivel and Encore Pro SmartCard are registered trademarks of Respironics, Inc.

NOTE: The C-Flex mark is used under license.

©Respironics, Inc. 2004

Intended Use

The Respironics REMstar Pro 2 with C-Flex system is a CPAP (Continuous Positive Airway Pressure) device designed for the treatment of adult Obstructive Sleep Apnea (OSA) only.

The REMstar Pro 2 with C-Flex is to be used only on the instruction of a licensed health care professional. Your home care provider will make the correct pressure settings according to your health care professional's prescription.

Several accessories are available to make your OSA treatment with the REMstar Pro 2 with C-Flex CPAP system as convenient and comfortable as possible. To ensure that you receive the safe, effective therapy prescribed for you, use only Respironics accessories.

IMPORTANT!

Read and understand the entire user manual before operating this system. If you have any questions concerning the use of this system, contact your home care provider or health care professional.

Contraindications

Studies have shown that the following pre-existing conditions may contraindicate the use of positive airway pressure therapy for some patients:

- Bullous Lung Disease
- Bypassed Upper Airway
- Pneumothorax
- Pathologically Low Blood Pressure
- Pneumocephalus has been reported in a patient using nasal Continuous Positive Airway Pressure. Caution should be used when prescribing CPAP for susceptible patients such as those with: cerebral spinal fluid (CSF) leaks, abnormalities of the cribriform plate, prior history of head trauma, and/or pneumocephalus. (Chest 1989; 96:1425-1426)

The use of positive airway pressure therapy may be temporarily contraindicated if you exhibit signs of a sinus or middle ear infection. Contact your health care professional if you have any questions concerning your therapy.

Specifications

Device Size	Dimensions: 9 1/2" x 6 7/8" x 4 1/2" (24 x 17 x 12 cm) Weight: <4.0 lbs. (<1.8 kg)												
Product Use, Transport, and Storage	<table><thead><tr><th></th><th>Operation</th><th>Transport & Storage</th></tr></thead><tbody><tr><td>Temperature:</td><td>41 to 95° F (5 to 35° C)</td><td>-4 to 140° F (-20 to 60° C)</td></tr><tr><td>Humidity:</td><td>15 to 95% Non-condensing</td><td>15 to 95% Non-condensing</td></tr><tr><td>Atmospheric Pressure:</td><td>83 to 102 kPascals</td><td>N/A</td></tr></tbody></table>		Operation	Transport & Storage	Temperature:	41 to 95° F (5 to 35° C)	-4 to 140° F (-20 to 60° C)	Humidity:	15 to 95% Non-condensing	15 to 95% Non-condensing	Atmospheric Pressure:	83 to 102 kPascals	N/A
	Operation	Transport & Storage											
Temperature:	41 to 95° F (5 to 35° C)	-4 to 140° F (-20 to 60° C)											
Humidity:	15 to 95% Non-condensing	15 to 95% Non-condensing											
Atmospheric Pressure:	83 to 102 kPascals	N/A											
Standards Compliance	This device is designed to conform to the following standard: IEC 60601-1 General Requirements for Safety of Medical Electrical Equipment IEC 60601-1-2:2001-09 Electromagnetic Compatibility - Requirements and Tests EN ISO 17510-1 Sleep Apnea Breathing Therapy Devices												
Mode of Operation	Continuous												
AC Power Consumption	100 - 240 VAC, 50/60 Hz, 1.0 A max.												
Type of Protection Against Electric Shock	Class II Equipment												
Degree of Protection Against Electric Shock	Type BF Applied Part												
Degree of Protection Against Ingress of Water	IPX0 - Ordinary Equipment												
Pressure Range	4 to 20 cm H ₂ O (in 0.5 cm increments)												
Pressure Stability	4 to 10 cm H ₂ O (±0.5 cm H ₂ O) >10 to 20 cm H ₂ O (±1.0 cm H ₂ O) Measured in accordance with EN 17510 @ 6.6, 13.2, & 20 cm H ₂ O @ 500 ml with BPM set to 10, 15, & 20 BPM performed at 23° C (±2° C), 50% RH (±5%), and an atmospheric pressure of 101.54 kPascals.												
Sound Pressure Level	<30 dB(A) Measured in accordance with EN 17510 @ 10 cm H ₂ O at the patient circuit. This measurement applies to the REMstar Pro 2 with C-Flex with or without the optional REMstar Heated Humidifier.												
Maximum Flow	34 LPM Measured in accordance with EN 17510 @ 6.6, 13.2, & 20 cm H ₂ O @ 500 ml with BPM set to 10, 15, & 20 BPM @ 23° C (±2° C), 50% RH (±5%), and an atmospheric pressure of 101.54 kPascals.												

Warnings & Cautions

CAUTION!

- *US federal law restricts this device to sale by or on the order of a physician.*

WARNING!

Indicates the possibility for injury to the user or the operator.

- *The instructions in this manual are not intended to supersede established medical protocols.*
- *This device is intended for adult use only.*
- *This device is not intended for life support.*
- *CPAP devices have the potential to allow rebreathing of exhaled air. To reduce this potential, observe the following:*
 - *Use Respironics circuit accessories.*
 - *Do not wear the mask and headgear for more than a few minutes while the device is not operating.*
 - *Do not block or try to seal the vent holes in the exhalation port.*

As with most CPAP devices: *At low CPAP pressures, some exhaled gas (CO₂) may remain in the mask and be rebreathed.*

- *Do not use this device if the room temperature is warmer than 95° F (35° C). If this device is used at room temperatures warmer than 95° F (35° C), the temperature of the airflow may exceed 106° F (41° C). This could cause irritation to your airway.*
- *This equipment is not suitable for use in the presence of a flammable anaesthetic mixture in combination with oxygen or air, or in the presence of nitrous oxide.*
- *If you notice any unexplained changes in the performance of the REMstar Pro 2 with C-Flex, if it is making unusual or harsh sounds, if it has been dropped or mishandled, if the enclosure is broken, or if water has entered the enclosure, disconnect the power cord and discontinue use. Contact your home care provider.*
- *To avoid electrical shock, disconnect the power cord before cleaning. DO NOT immerse the device in any fluids.*
- *Contact your health care professional if symptoms of sleep apnea recur.*
- *Pins of connectors identified with the ESD warning symbol should not be touched. Connections should not be made to these connectors unless ESD precautionary procedures are used. Precautionary procedures include methods to prevent build-up of electrostatic discharge (e.g., air conditioning, humidification, conductive floor coverings, non-synthetic clothing), discharging one's body to the frame of the equipment or system or to earth or a large metal object, and bonding oneself by means of a wrist strap to the equipment or system or to earth.*

Unpacking the System

CAUTION!

Indicates the possibility of damage to the device.

- Tobacco smoke may cause tar build-up within the REMstar Pro 2 with C-Flex that may result in the REMstar Pro 2 with C-Flex malfunctioning.
- The use of accessories other than those specified, with the exception of cables sold by the manufacturer of the equipment or system as replacement parts for internal components, may result in increased emissions or decreased immunity of the equipment or system.

Additional warnings and cautions are located throughout this manual as they apply.

After unpacking the system, make sure you have everything shown here:

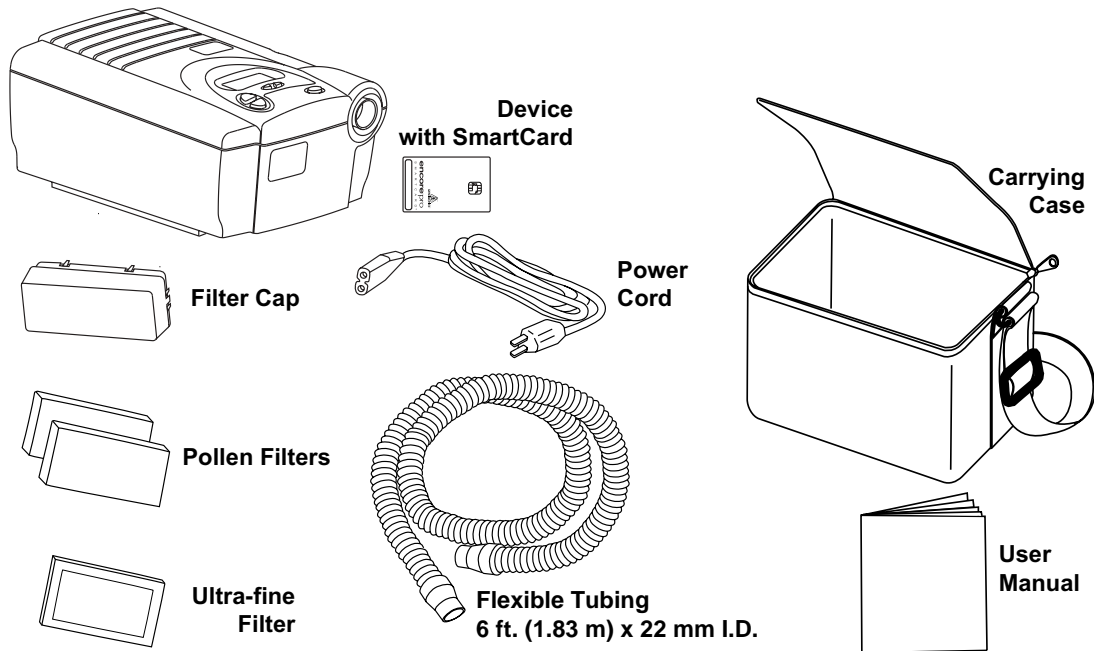

IMPORTANT! If any of the above parts are missing, contact your home care provider.

The Encore® Pro SmartCard® records CPAP usage. The SmartCard also can record your answers to the FOSQ “Quality of Life” questionnaire. Your health care professional or home care provider may ask you to periodically complete this questionnaire. Your answers can be recorded on the SmartCard or you can circle your answers on the enclosed FOSQ brochure.



System Features

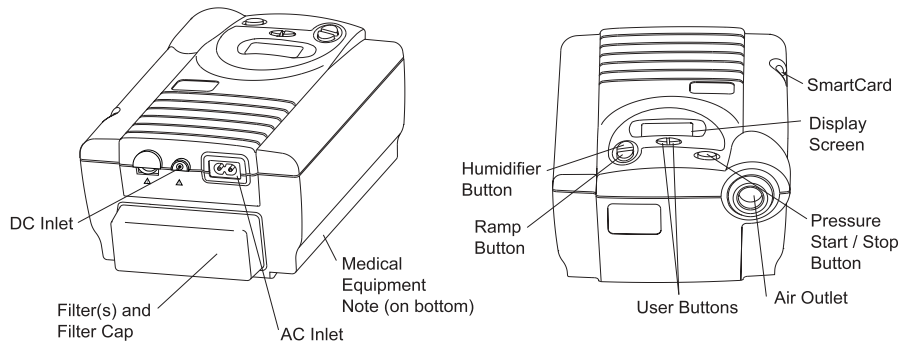

AC Inlet Connect/disconnect the AC power cord here.

Air Outlet Connect the flexible tubing here.

DC Inlet Connect the optional DC power cord here.

Display Screen All system settings, total operating time, and therapy hours will appear here. Displays the pressure settings.

Filter Cap & Filters The pollen filter screens out normal household dust and pollens. The optional, ultra-fine filter is also included for more complete filtration of very fine particles. The filter cap is designed to reduce the noise from the REMstar Pro 2 with C-Flex.

Humidifier Button This button turns the REMstar Heated Humidifier on/off and allows the heat setting to be adjusted. The humidifier is an optional accessory that may be purchased separately.

Medical Product Note For ease at airport security stations, there is a note on the bottom of the REMstar Pro 2 with C-Flex stating that it is medical equipment. It may help if you also take this manual with you when you travel.

Pressure Start/Stop

Button This button starts/stops the airflow.

Ramp Button This button starts the ramp cycle or accesses the REMstar Pro 2 with C-Flex settings.

SmartCard The SmartCard records device usage information (e.g., length of time the system was used for therapy). Contact your home care provider for further information about the SmartCard.

User Buttons These buttons can be used to change some of the system settings and to answer the FOSQ quality of life questionnaire.

First Time Setup

WARNING!

Do not use the REMstar Pro 2 with C-Flex system until an appropriate professional adjusts the settings! To order any accessories not included with this system, contact your home care provider.

Note to home care provider: Before beginning setup, be sure that you have available the REMstar Pro 2 with C-Flex Home Care Provider Setup Instructions. Setup instructions are not provided in this manual.

WARNING!

DO NOT connect any equipment to the REMstar Pro 2 with C-Flex unless recommended by Respironics or your health care provider.

CAUTION!

If the REMstar Pro 2 with C-Flex has been exposed to either very hot or very cold temperatures, allow it to adjust to room temperature (approximately 2 hours) before beginning setup.

SmartCard

The REMstar Pro 2 with C-Flex comes with a SmartCard installed in the side of the device to record information for the home care provider. Your home care provider may ask you to periodically remove the SmartCard and send it to him/her for evaluation.

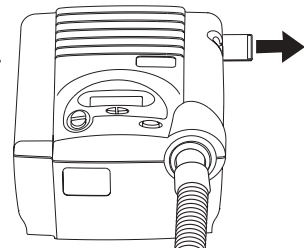

ATTENTION!

The SmartCard does not need to be installed for the REMstar Pro 2 with C-Flex to work properly. The SmartCard records device usage information for use by your home care provider. Contact your home care provider if you have any questions about the SmartCard.

First Time Setup

Installing the Filter

CAUTION!

1. Install the filters and filter cap.

The pollen filter must be in place at all times when the REMstar Pro 2 with C-Flex is operating. The white ultra-fine filter is optional and can be used in addition to the pollen filter. The ultra-fine filter is recommended for people who are sensitive to tobacco smoke or other small particles.

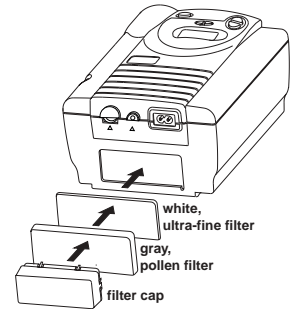

- a. Place one of the pollen filters over the ultra-fine filter. If you are not using the ultra-fine filter, simply place the pollen filter into the filter area on the back of the REMstar Pro 2 with C-Flex. An extra filter is included for your convenience.
- b. Attach the filter cap. Position the cap so that the small opening on the cap is facing down. Insert the cap's tabs into the filter area opening.

Power Cord

2. Connect the power cord. Plug the socket end of the power cord into the AC inlet on the back of the REMstar Pro 2 with C-Flex. Plug the pronged end of the power cord into an electrical outlet.

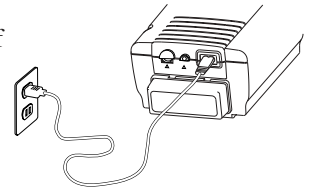

IMPORTANT!

To remove AC power, disconnect the power cord from the electrical outlet.

WARNING!

Inspect the power cord often for any signs of damage. Replace a damaged cord immediately.

WARNING!

The REMstar Pro 2 with C-Flex is activated and ready for use when the power cord is connected. The pressure start / stop button turns the blower on/off.

CAUTION!

3. Place the REMstar Pro 2 with C-Flex on a firm, flat surface.

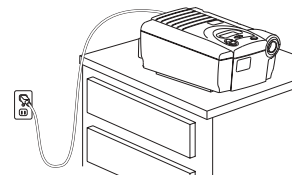

Make sure the REMstar Pro 2 with C-Flex is away from any heating or cooling equipment (e.g., forced air vents, radiators, air conditioners). Also make sure that bedding, curtains, or other items are not blocking the filter or vents of the device. Air must flow freely around the device for the system to work properly.

First Time Setup

Device Settings

Once the power cord is plugged in, REMstar Pro 2 with C-Flex's system version number, the total hours of use, and then the total therapy hours will appear. The word "Card" in the lower right corner of the display screen signifies that the SmartCard is installed.

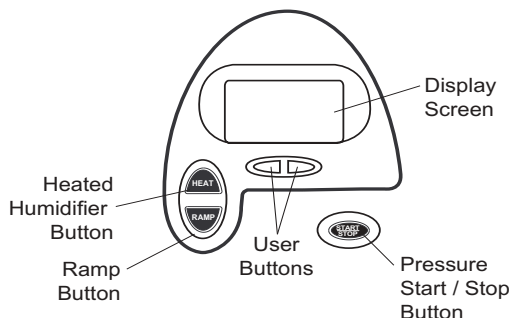

Display Screen: All device settings will appear here.

Pressure Start/Stop Button: Use this button to start/stop the airflow. DO NOT start the airflow until the circuit tubing is connected.

Heated Humidifier Button: Use this button when the optional REMstar Heated Humidifier has been prescribed. This button will control the optional heated humidifier's output. Follow the instructions included with the humidifier.

Ramp Button: When the airflow is turned on, use this button to start the ramp cycle (which lowers the airflow pressure). This will allow you to fall asleep more comfortably. When the airflow is turned off, use this button to access the patient menu. *Note: The ramp feature is not prescribed for all users.*

User Buttons: These buttons can be used when entering various menus to change some of the REMstar Pro 2 with C-Flex settings.

IMPORTANT!

In the Setup Menu, the humidifier and ramp buttons operate as up and down keys to change the settings, the left/right user buttons are used to go to the previous/next question or setting, and the start/stop button will allow you to exit the Settings Menu.

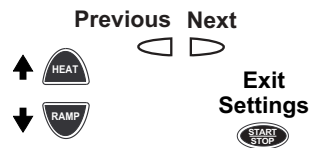

First Time Setup

Device Settings

4. **Verify/Change the REMstar Pro 2 with C-Flex settings.** To start the setup menu, press and hold the ramp button until the device beeps (The airflow must be turned off.)

IMPORTANT! *Pressing the ramp button (when the airflow is turned on) will lower the airflow pressure, if prescribed.*

WARNING! *DO NOT use the REMstar Pro 2 with C-Flex if the display is erratic. Contact your home care provider for further instructions.*

IMPORTANT! *If at any time you wish to exit the setup menu, press the pressure on/off button and the display will go back to the main screen.*

Therapy Hours

- a. **The number of nights the REMstar Pro 2 with C-Flex was used for therapy for more than 4 hours will appear.** This screen is only for reference. Your home care provider may periodically ask you for this information.

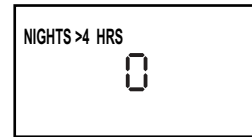

Press the right user button to go to the next setting.

Setting the C-Flex™ Level

- b. **The C-Flex level setting displays the C-Flex level set by your home care provider.** *Note: This setting will only appear if C-Flex was prescribed for you.*

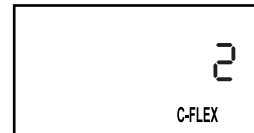

This setting allows you to adjust the level of air pressure relief that you feel when you exhale during therapy.

Your home care provider will have already set a C-Flex level. If this is not comfortable for you, you can increase or decrease the setting. The setting of “1” provides a small amount of pressure relief. To increase the pressure relief, change the setting to “2” or “3.”

To change the setting, press the ramp or humidifier button.

Press the right user button to go to the next setting.

First Time Setup

Setting the Ramp Starting Pressure

- c. **The ramp starting pressure will appear.** *Note: This setting will only appear if ramp was prescribed for you.*

The ramp feature will reduce the pressure and then gradually increase (ramp) the pressure to the prescription pressure setting so that you can fall asleep more comfortably.

Your home care provider will have already set a ramp starting pressure. If you feel the ramp starting pressure is set too low or too high, you can change the setting.

(Range: 4 cm H₂O - Prescription Pressure)

To change the setting, press the ramp or humidifier button.
(You can hold the button down to make the setting change faster.)



Turning the Alert Tone On or Off

- d. **The patient disconnect alert setting will appear and flash.** This setting has two functions. When a large, continuous air leak (such as mask removal) has been detected in the circuit, it enables/disables the audible alert (a beeping sound) and the Auto-off feature that allows the REMstar Pro 2 with C-Flex to automatically turn the airflow OFF. You have the option of turning the alert tone on or off.

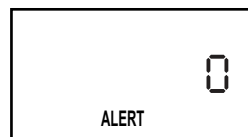

1 = on 0 = off

To change the setting, press the ramp or humidifier button until the correct setting appears.

Press the right user button to go to the next setting.

Setting the Button Lights

- e. **The button lights setting will appear and flash.** This setting allows you to have the lights behind the buttons turned on or off while the airflow is turned on. (The lights will always be on when the airflow is off.)

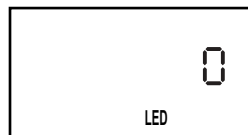

1 = on 0 = off

To change the setting, press the ramp or humidifier button until the correct setting appears.

Press the right user button to go to the next setting.

FOSQ

f. FOSQ will appear and flash.

Note: FOSQ will only appear if the SmartCard has been installed. If the SmartCard is not installed, go to Step c.



FOSQ is a “quality of life” questionnaire designed specifically for people with sleep disorders. The results allow health care professionals to see how therapy has improved the quality of your life. The REMstar Pro 2 with C-Flex has the ability to record your answers on the SmartCard for later review by your health care professional.

To take the FOSQ test, go to page 18 for instructions.

To skip the FOSQ test and continue with the settings, press the right user button.

The settings are complete. Press the pressure start/stop button to exit the settings menu. Or, if you want to return to step a, press the right user button.

First Time Setup

Assembling the Circuit

5. Assemble the circuit. To use the system, you will need the following accessories in order to assemble the recommended circuit.
- *Respironics nasal mask with integrated exhalation port* (or *Respironics mask with separate exhalation port such as the Whisper Swivel® II*)
 - *Respironics 6 ft. (1.83 m) x 22 mm I.D. flexible tubing*
 - *Respironics headgear* (for the mask)

WARNING!

If the REMstar Pro 2 with C-Flex is used for multiple persons (e.g., rental devices) a low-resistance, main flow bacteria filter should be installed in-line between the REMstar Pro 2 with C-Flex and the circuit tubing. Pressures must be verified by your home care provider when alternate or optional accessories are in place.

- a. Connect the flexible tubing to the air outlet on the front of the REMstar Pro 2 with C-Flex.

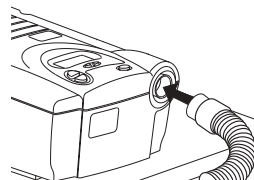

- b. *If you are using a mask with a built-in exhalation port*, connect the mask's connector to the flexible tubing.

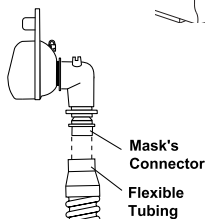

If you are using a mask with a separate exhalation port, connect the flexible tubing to the exhalation port. Position the exhalation port so that the vented air is blowing away from your face. Connect the mask's connector to the exhalation port.

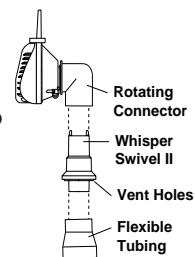

WARNING!

Do not block or otherwise try to seal the air openings (vent holes) on the exhalation port. Explanation of the warning: The REMstar Pro 2 with C-Flex is intended to be used with masks and circuits that have an exhalation port designed to exhaust CO₂ from the circuit. When the REMstar Pro 2 with C-Flex is turned on and functioning properly, new air from the REMstar Pro 2 with C-Flex flushes the exhaled air out through the exhalation port. When the REMstar Pro 2 with C-Flex is turned off, enough fresh air will not be provided through the mask, and exhaled air may be rebreathed. Rebreathing of exhaled air for longer than several minutes can, in some circumstances, lead to suffocation. This warning applies to most CPAP devices.

WARNING!

If you are using a full face mask (i.e., a mask covering both your mouth and your nose), the mask must be equipped with a safety (entrainment) valve.

Contact your home care provider for additional information on the accessories available for the REMstar Pro 2 with C-Flex system. When using optional accessories, always follow the instructions enclosed with the accessories.

Adding a Humidifier

The REMstar Heated Humidifier and Pass-over humidifier are available from your home care provider. The humidifiers may reduce nasal dryness and irritation by adding moisture (and heat if applicable) to the airflow.

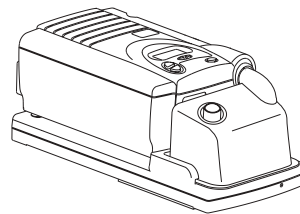

WARNING!

Always place the humidifier at the same level or lower than the REMstar Pro 2 with C-Flex device and the mask so that any excess condensation in the tubing drains back into the water chamber. The humidifier must be level for proper operation. DC power cannot be used to operate the heated humidifier.

Adding Oxygen

Oxygen may be added at the mask connection. Please note the warnings listed below when using oxygen with the REMstar Pro 2 with C-Flex.

WARNING!

The oxygen supply must comply with the local regulations for medical oxygen.

WARNING!

A Respironics Pressure Valve (part number 302418) must be placed in-line with the patient circuit.

WARNING!

*Oxygen accelerates fires. Keep the REMstar Pro 2 with C-Flex and the oxygen container away from heat, open flames, any oily substance, or other sources of ignition. **DO NOT** smoke in the area near the REMstar Pro 2 with C-Flex or the oxygen container.*

WARNING!

*If oxygen is used with this CPAP machine, the oxygen flow must be turned off when the CPAP machine is not operating.
Explanation of warning: When the CPAP device is not in operation and the oxygen flow is left on, oxygen delivered to the ventilator tubing may accumulate within the CPAP machine enclosure. Oxygen accumulated in the CPAP machine enclosure will create a risk of fire. This warning applies to most types of CPAP machines.*

WARNING!

At a fixed flow rate of supplemental oxygen flow, the inhaled oxygen concentration will vary depending on the pressure settings, patient breathing pattern, mask selection and leak rate. This warning applies to most types of CPAP machines.

Routine Use

Using DC Power

You can also use the REMstar Pro 2 with C-Flex in a stationary recreational vehicle, boat, or motor home with a 12 volt DC power source. Do not operate the REMstar Pro 2 with C-Flex while the vehicle is in motion. Contact your home care provider for additional information.

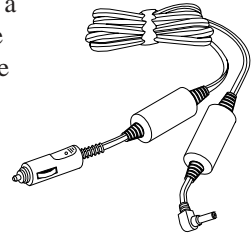

CAUTION!

Use only the Respironics DC power system available from your home care provider. Use of any other system may cause damage to the REMstar Pro 2 with C-Flex or your vehicle.

Connecting the Circuit

IMPORTANT!

Before each use, examine the flexible tubing for any damage or debris. If necessary, clean the tubing to remove the debris. Replace any damaged tubing.

1. Connect the circuit.

a. **Connect the mask to the headgear, following the instructions included with the headgear.**

b. **Put on the mask and headgear, and breathe normally through your nose.** The airflow should automatically start when you begin breathing through the circuit. If the airflow does not start within four breaths, press the pressure start/stop button on the top of the REMstar Pro 2 with C-Flex. When operating the system with some mask types or some circuit configurations, the airflow may NOT start automatically.

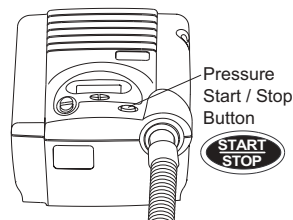

Adjusting the Circuit

2. **Adjust the circuit.** Lie down on your bed, and adjust the flexible tubing so it is free to move if you turn in your sleep. Adjust the mask and headgear until you have a comfortable fit and there are no airflow leaks into your eyes.

Using the Ramp Button

Pressing the Ramp button will reduce the air pressure when you are trying to fall asleep. The air pressure will gradually increase until your prescription pressure is reached. **If your health care professional prescribed ramp for you, pressing the button will reduce the pressure and then gradually increase (ramp) the pressure to the therapeutic pressure setting so that you can fall asleep more comfortably.** *Note: The ramp feature is not prescribed for all users.*

3. Press the Ramp button on the top of the REMstar Pro 2 with C-Flex. You can use the Ramp button as often as you wish during the night.

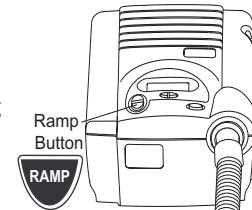

Turning the System OFF

4. Remove the mask and headgear. Press the pressure on/off button on the top of the REMstar Pro 2 with C-Flex to turn the airflow OFF.

Or, if the patient disconnect alert setting has been turned on, the airflow will automatically turn off. When you remove the mask, the airflow will decrease to a low pressure. After approximately 45 seconds the alert tone will sound. Then the airflow will automatically turn off (in less than 2 minutes after you remove the mask).

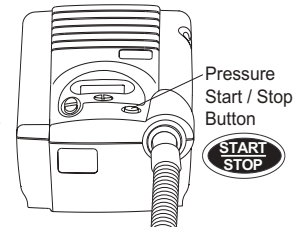

IMPORTANT!



The humidifier button is active only when a REMstar Heated Humidifier is connected or when the REMstar Pro 2 with C-Flex is in the Setup Menu. Refer to the REMstar Heated Humidifier's instructions for additional information.

Helpful Hints

- If the alert tone sounds, press any button on the REMstar Pro 2 with C-Flex to silence the alert tone. Refer to the “Troubleshooting” section of the manual for further instructions.
- Make sure that bedding, curtains, or other items are not blocking the filter or vents of the REMstar Pro 2 with C-Flex. Air must flow freely around the REMstar Pro 2 with C-Flex for the system to work properly.
- If the airflow from the REMstar Pro 2 with C-Flex feels cold, reposition the circuit tubing so that it runs under your bed covers to reduce heat loss while you sleep.

Taking the FOSQ Test

If your health care professional or home care provider instructs you to complete the FOSQ “quality of life” questionnaire, you can enter your answers into the REMstar Pro 2 with C-Flex.

1. **Make sure that the SmartCard is installed in the side of the REMstar Pro 2 with C-Flex.**

Answers to the questions are saved onto the SmartCard.

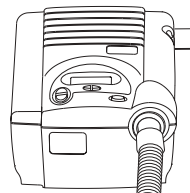

2. **To start the questionnaire, press and hold the ramp button until the REMstar Pro 2 with C-Flex beeps. (The airflow must be turned off.) The number of nights the REMstar Pro 2 with C-Flex was used for therapy for more than 4 hours will appear. This screen is only for reference.**

Press the left user button.

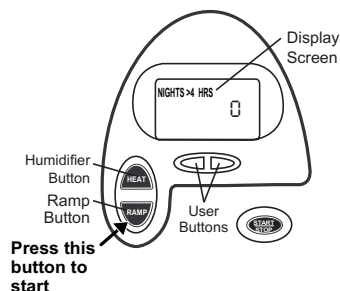

3. **The word FOSQ will appear on the display and flash.** In the lower right corner of the screen, the word “Card” will appear so that you know the SmartCard has been installed properly.

Press the humidifier button. The word FOSQ will stop flashing. The number of the question will appear to the left of the colon, and the answer will appear to the right and flash. Using the FOSQ brochure (from your home care provider), read each question. The answer selection will be printed below the question.

Press the humidifier or ramp button to change the answer.

Press the right user button to go to the next question. Press the left user button to go to the previous question if needed.

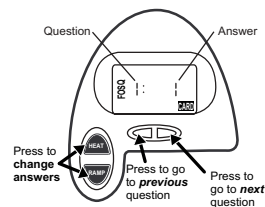

4. **After all of the questions have been answered, press the right user button to exit the questionnaire.**

Routine Maintenance

Cleaning the Filter

The gray pollen filter should be cleaned at least once every two weeks under normal usage and replaced with a new one every six months. The white ultra-fine filter is disposable and should be replaced after 30 nights of use or sooner if it appears dirty. DO NOT clean the ultra-fine filter.

CAUTION!

Operating the REMstar Pro 2 with C-Flex with a dirty filter may keep the system from working properly and may damage the REMstar Pro 2 with C-Flex.

1. Remove the filter cap by gently pressing on its sides.
2. Change the filter.
 - a. Remove the pollen filter by gently pulling around the edges of the filter. Rinse the filter in a steady stream of running water. Squeeze out the water and repeat. Air dry the filter on a rack for 8 to 12 hours or in a clothes dryer for 15 to 20 minutes.

If you are using the white ultra-fine filter and it appears dirty, discard the filter and replace it with a new one.
 - b. Place the white ultra-fine filter under the clean pollen filter. Insert the filter(s) into the filter area on the back of the REMstar Pro 2 with C-Flex. Replace the filter cap.

CAUTION!

Never install a wet filter into the REMstar Pro 2 with C-Flex. We recommend that you clean the filter in the morning and alternate using the two filters provided with the system to ensure enough drying time for the cleaned filter.

Cleaning the System

WARNING!

Clean the mask and tubing daily.

To avoid electrical shock, unplug the REMstar Pro 2 with C-Flex before cleaning. Do not immerse the REMstar Pro 2 with C-Flex in any fluids.

1. Disconnect the flexible tubing from the REMstar Pro 2 with C-Flex. Gently wash the flexible tubing in a solution of warm water and a mild detergent. Rinse the tubing thoroughly and air dry.
2. Wipe the outside of the REMstar Pro 2 with C-Flex with a cloth slightly dampened with water and a mild detergent. Let the REMstar Pro 2 with C-Flex dry before plugging in the power cord.
3. Inspect the REMstar Pro 2 with C-Flex and all circuit parts for any damage after cleaning. Replace any damaged parts.
4. For details on cleaning your mask and accessories, refer to the cleaning instructions packaged with the accessories.

Reordering / Service / Traveling with the System

Reordering

Contact your home care provider to order accessories or replacement filters.

Service

The REMstar Pro 2 with C-Flex system does not require routine servicing.

WARNING!

If you notice any unexplained changes in the performance of the REMstar Pro 2 with C-Flex, if it is making unusual or harsh sounds, if it has been dropped or mishandled, if the enclosure is broken, or if water has entered the enclosure, discontinue use. Contact your home care provider.

WARNING!

If the REMstar Pro 2 with C-Flex malfunctions, contact your home care provider immediately. Never attempt to open the REMstar Pro 2 with C-Flex's enclosure. Repairs and adjustments must be performed by Respiroics authorized service personnel only. Unauthorized service could cause injury, invalidate the warranty, or result in costly damage.

Disposal

When necessary, dispose of the REMstar Pro 2 with C-Flex and accessories in accordance with local regulations.

Packing the System

When you are traveling, the carrying case is for carry-on luggage *only*. The carrying case will not protect the system if it is stored as checked baggage.

Security Stations

For convenience at security stations, there is a note on the bottom of the REMstar Pro 2 with C-Flex stating that it is medical equipment. It may be helpful to bring this manual along with you to help security personnel understand the REMstar Pro 2 with C-Flex.

Checking the Power Cord

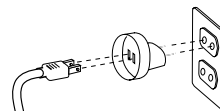

If you are traveling to a country with a line voltage different than the one you are currently using, a different power cord or an international plug adapter may be required to make your power cord compatible with the power outlets of the country to which you are traveling.

Contact your home care provider for additional information.



Troubleshooting

The table below lists common problems you may have with the REMstar Pro 2 with C-Flex system and possible solutions to those problems. If none of the corrective actions solve the problem, contact your home care provider.

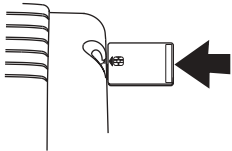
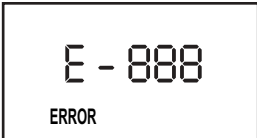
Problem	Solution(s)
<p>“ALERT” is flashing on the display screen and the alert tone is sounding.</p> 	<p>Press any button on the REMstar Pro 2 with C-Flex to silence the alert tone and stop the flashing. The system has detected a large leak in the circuit or you have taken the mask off without turning the airflow off. Check the circuit connections for leaks.</p>
<p>“Error”, “Card”, and an error code (C-???) are flashing on the display screen and the alert tone is sounding.</p> 	<p>The SmartCard is installed incorrectly or is damaged. Remove the SmartCard and verify that it was installed as shown. Reinsert the SmartCard. If the alert tone sounds again, remove the SmartCard, and contact your home care provider or Respironics for directions on having the SmartCard replaced. Please have the error code ready when you call.</p> 
<p>“Error” and an error code (E-???) are flashing on the display screen, the alert tone is sounding, and the buttons are flashing.</p> 	<p>Press any button on the REMstar Pro 2 with C-Flex to silence the alert tone. Discontinue use. Disconnect the power cord from the AC wall outlet. Contact your home care provider or Respironics for directions on having the REMstar Pro 2 with C-Flex serviced. Please have the device’s serial number and the error code ready when you call.</p>
<p>The pressure being delivered feels different.</p>	<p>Contact your home care provider or Respironics for directions on having the REMstar Pro 2 with C-Flex serviced. Please have the device’s serial number ready when you call.</p>

Troubleshooting

Problem	Solution(s)
The airflow from the REMstar Pro 2 with C-Flex seems warm.	Replace or clean the filter. Make sure the REMstar Pro 2 with C-Flex is away from bedding or curtains that could block the flow of air around the REMstar Pro 2 with C-Flex. Make sure the REMstar Pro 2 with C-Flex is away from heating equipment (e.g., forced air vents, radiators).
The noise level of the REMstar Pro 2 with C-Flex has changed to include unusual or harsh sounds during operation.	Contact your home care provider or Respironics for directions on having the REMstar Pro 2 with C-Flex serviced. Please have the device's serial number ready when you call.
The REMstar Pro 2 with C-Flex will not turn on.	Make sure that the REMstar Pro 2 with C-Flex is plugged into a working outlet. If you are using DC power accessories with a battery, the battery may need to be recharged or replaced or the DC Cord's fuse may need to be replaced. Contact your home care provider or Respironics for directions on having the REMstar Pro 2 with C-Flex serviced. Please have the device's serial number ready when you call.
Pressing the ramp button does not reduce the air pressure.	Contact your home care provider. Ramp may not have been prescribed for you.
The REMstar Pro 2 with C-Flex has been dropped into water or fluids have gotten into the enclosure.	Discontinue use. Disconnect the power cord from the AC wall outlet. Contact your home care provider or Respironics for directions on having the REMstar Pro 2 with C-Flex serviced. Please have the device's serial number ready when you call.

EMC Requirements

Guidance and Manufacturer's Declaration - Electromagnetic Emissions

This device is intended for use in the electromagnetic environment specified below. The user of this device should make sure it is used in such an environment.

Emissions Test	Compliance	Electromagnetic Environment - Guidance
RF emissions CISPR 11	Group 1	This device uses RF energy only for its internal function. Therefore, its RF emissions are very low and are not likely to cause any interference in nearby electronic equipment. This device is suitable for use in all establishments, including domestic establishments and those directly connected to the public low-voltage power supply network.
RF emissions CISPR 11	Class B	
Harmonic emissions IEC 61000-3-2	N/A	
Voltage fluctuations/ Flicker emissions IEC 61000-3-3	Complies	

EMC Requirements (cont.)

Guidance and Manufacturer's Declaration - Electromagnetic Immunity

This device is intended for use in the electromagnetic environment specified below. The user of this device should make sure it is used in such an environment.

Immunity Test	IEC 60601 Test Level	Compliance Level	Electromagnetic Environment - Guidance
Electrostatic Discharge (ESD) IEC61000-4-2	±6 kV contact ±8 kV air	±6 kV contact ±8 kV air	Floors should be wood, concrete or ceramic tile. If floors are covered with synthetic material, the relative humidity should be at least 30%.
Electrical fast Transient/burst IEC 61000-4-4	±2 kV for power supply lines ±1 kV for input-output lines	±2 kV for supply mains ±1 kV for input/output lines	Mains power quality should be that of a typical home or hospital environment.
Surge IEC 61000-4-5	±1 kV differential mode ±2 kV common mode	±1 kV differential mode ±2 kV for common mode	Mains power quality should be that of a typical home or hospital environment.
Voltage dips, short interruptions and voltage variations on power supply input lines IEC 61000-4-11	<5% U_T (>95% dip in U_T) for 0.5 cycle 40% U_T (60% dip in U_T) for 5 cycles 70% U_T (30% dip in U_T) for 25 cycles <5% U_T (>95% dip in U_T) for 5 sec	<5% U_T (>95% dip in U_T) for 0.5 cycle 40% U_T (60% dip in U_T) for 5 cycles 70% U_T (30% dip in U_T) for 25 cycles <5% U_T (>95% dip in U_T) for 5 sec	Mains power quality should be that of a typical home or hospital environment. If the user of the device requires continued operation during power mains interruptions, it is recommended that the device be powered from an uninterruptible power supply or a battery.

NOTE: U_T is the a.c. mains voltage prior to application of the test level.

EMC Requirements (cont.)

Guidance and Manufacturer's Declaration - Electromagnetic Immunity

This device is intended for use in the electromagnetic environment specified below. The user of this device should make sure it is used in such an environment.

Immunity Test	IEC 60601 Test Level	Compliance Level	Electromagnetic Environment - Guidance
Power frequency (50/60 Hz) magnetic field IEC 61000-4-8	3 A/m	3 A/m	Power frequency magnetic fields should be at levels characteristic of a typical location in a typical home or hospital environment.
Conducted RF IEC 61000-4-6 Radiated RF IEC 61000-4-3	3 Vrms 150 kHz to 80 MHz 3 V/m 80 MHz to 2.5 GHz	3 Vrms 3 V/m	<p>Portable and mobile RF communications equipment should be used no closer to any part of the device, including cables, than the recommended separation distance calculated from the equation applicable to the frequency of the transmitter.</p> <p>Recommended separation distance $d = 1.2 \sqrt{P}$</p> <p>$d = 1.2 \sqrt{P}$ 80 MHz to 800 MHz $d = 2.3 \sqrt{P}$ 800 MHz to 2.5 GHz</p> <p>where P is the maximum output power rating of the transmitter in watts (W) according to the transmitter manufacturer and d is the recommended separation distance in meters (m).</p> <p>Field strengths from fixed RF transmitters, as determined by an electromagnetic site survey,^a should be less than the compliance level in each frequency range.^b</p> <p>Interference may occur in the vicinity of equipment marked with the following symbol:</p> <div style="text-align: center;">  </div>
<p>NOTE 1 At 80 MHz and 800 MHz, the higher frequency range applies.</p> <p>NOTE 2 These guidelines may not apply in all situations. Electromagnetic propagation is affected by absorption and reflection from structures, objects, and people.</p> <p>^a Field strengths from fixed transmitters, such as base stations for radio (cellular/cordless) telephones and land mobile radios, amateur radio, AM and FM radio broadcast and TV broadcast cannot be predicted theoretically with accuracy. To assess the electromagnetic environment due to fixed RF transmitters, an electromagnetic site survey should be considered. If the measured field strength in the location in which the device is used exceeds the applicable RF compliance level above, the device should be observed to verify normal operation. If abnormal performance is observed, additional measures may be necessary, such as re-orienting or relocating the device.</p> <p>^b Over the frequency range 150 kHz to 80 MHz, the field strengths should be less than 3 V/m.</p>			

EMC Requirements (cont.)

RECOMMENDED SEPARATION DISTANCES BETWEEN PORTABLE AND MOBILE RF COMMUNICATIONS EQUIPMENT AND THIS DEVICE

This device is intended for use in an electromagnetic environment in which radiated RF disturbances are controlled. The customer or the user of this device can help prevent electromagnetic interference by maintaining a minimum distance between portable and mobile RF communications equipment (transmitters) and this device as recommended below, according to the maximum output power of the communications equipment.

Rated Maximum Power Output of Transmitter W	Separation Distance According to Frequency of Transmitter m		
	150 kHz to 80 MHz $d = 1.2\sqrt{P}$	80 MHz to 800 MHz $d = 1.2\sqrt{P}$	800 MHz to 2.5 GHz $d = 2.3\sqrt{P}$
0.01	0.12	0.12	0.23
0.1	0.38	0.38	0.73
1	1.2	1.2	2.3
10	3.8	3.8	7.3
100	12	12	23

For transmitters rated at a maximum output power not listed above, the recommended separation distance d in meters (m) can be estimated using the equation applicable to the frequency of the transmitter, where P is the maximum output power rating of the transmitter, where P is the maximum output power rating of the transmitter in watts (W) according to the transmitter manufacturer.

Note 1: At 80 MHz and 800 MHz, the separation distance for the higher frequency range applies.

Note 2: These guidelines may not apply in all situations. Electromagnetic propagation is affected by absorption and reflection from structures, objects, and people.

Limited Warranty

Respironics, Inc.[®] warrants that the REMstar[®] Pro 2 with C-Flex CPAP device shall be free from defects of workmanship and materials and will perform in accordance with the product specifications for a period of two (2) years from the date of sale by Respironics, Inc. to the dealer. If the product fails to perform in accordance with the product specifications, Respironics, Inc. will repair or replace, at its option, the defective material or part. Respironics, Inc. will pay customary freight charges from Respironics, Inc. to the dealer location only. This warranty does not cover damage caused by accident, misuse, abuse, alteration and other defects not related to material or workmanship.

RESPIRONICS, INC. DISCLAIMS ALL LIABILITY FOR ECONOMIC LOSS, LOSS OF PROFITS, OVERHEAD OR CONSEQUENTIAL DAMAGES WHICH MAY BE CLAIMED TO ARISE FROM ANY SALE OR USE OF THIS PRODUCT. SOME STATES DO NOT ALLOW THE EXCLUSION OR LIMITATION OF INCIDENTAL OR CONSEQUENTIAL DAMAGES, SO THE ABOVE LIMITATION OR EXCLUSION MAY NOT APPLY TO YOU.

THIS WARRANTY IS GIVEN IN LIEU OF ALL OTHER EXPRESS WARRANTIES. IN ADDITION, ANY IMPLIED WARRANTIES, INCLUDING ANY WARRANTY OF MERCHANTABILITY OR FITNESS FOR THE PARTICULAR PURPOSE ARE LIMITED TO TWO YEARS. SOME STATES DO NOT ALLOW LIMITATIONS ON HOW LONG AN IMPLIED WARRANTY LASTS, SO THE ABOVE LIMITATION MAY NOT APPLY TO YOU. THIS WARRANTY GIVES YOU SPECIFIC LEGAL RIGHTS, AND YOU MAY ALSO HAVE OTHER RIGHTS WHICH VARY FROM STATE TO STATE.

To exercise your rights under this warranty, contact your local, authorized Respironics, Inc. dealer or Respironics, Inc. at 1001 Murry Ridge Lane, Murrysville, Pennsylvania 15668, 1-800-345-6443 (USA and Canada only) or 1-724-387-4000.

For information on sleep disorders, contact the following organizations:

American Sleep Apnea Association

1424 K Street NW, Suite 302

Washington, DC 20005

Telephone: 1-202-293-3650

Fax: 1-202-293-3656

Email: asaa@sleepapnea.org

www.sleepapnea.org

National Sleep Foundation

729 Fifteenth Street, N.W., Fourth Floor

Washington, DC 20005

www.sleepfoundation.org

IMPORTANT!

Fill in the information below when you receive the REMstar Pro 2 with C-Flex CPAP system.

Serial No.: _____ (Located on the bottom of the device)

System Prescribed for: _____

Date of Purchase or Rental: _____

Pressure Setting: _____ cm H₂O

Mask Type: _____

Mask Size: _____

If you have any questions concerning the system, contact:

• Home Care Company: _____

Telephone Number: _____

• Health Care Professional: _____

Telephone Number: _____

• Respironics, Inc.

1001 Murry Ridge Lane

Murrysville, Pennsylvania

15668-8550 USA

Customer Service

Telephone Number: 1-800-345-6443 (USA and Canada only) or 1-724-387-4000

An application to join the American Sleep Apnea Association should be attached here.
If it is not, you can contact the American Sleep Apnea Association at 1-202-293-3650.

Name _____ Phone No. () _____

Address _____ City _____ State _____ Zip _____

Please check: \$1000 \$500 \$250 \$100 \$50 \$25 annual membership*

All memberships include a one year subscription to the newsletter. Membership and contributions are deductible for income tax purposes within IRS rules. **Membership includes a free medical alert necklace or bracelet.**

I would like to become a member of the ASAA.

Please send me a free medical alert bracelet or necklace.

I am undecided, but please send me a free copy of the newsletter.

I would like to know if there is an A.W.A.K.E. group near me.

PLEASE SEND TO:

**American Sleep Apnea Association
1424 K Street NW, Suite 302, Washington D.C. 20005**



Respironics, Inc. provided a grant to and is recognized as a founding sponsor of the American Sleep Apnea Association. As a non-profit organization, the American Sleep Apnea Association does not endorse or recommend any company or product.

*For addresses outside the United States, the minimum contribution is U.S. \$50.00.

Join the American Sleep Apnea Association

As a member of the American Sleep Apnea Association, you will receive a newsletter, WAKE-UP CALL, six times each year. This newsletter will inform you about the latest in medical advances, new technology, human interest stories of individual accomplishment, home care tips, and legislative affairs. Also, you will receive a medical alert identification bracelet.

You are also invited to participate in the A.W.A.K.E. (Alert, Well And Keeping Energetic) Network, which is a nationwide system of local mutual help/support groups. A.W.A.K.E. meetings provide the opportunity to share information and support with others who have been affected by sleep apnea.



G

To reduce disability and death from Sleep Apnea and other breathing disorders during sleep.

O

To improve the clinical care of Sleep Apnea by educating the public and medical profession about the disorder.

A

To provide Sleep Apnea sufferers with information about new advances in the treatment of Sleep Apnea.

L

To establish and nurture mutual help/support groups for apnea sufferers and their families.

S

To raise money for and to sponsor research on the causes and treatment of Sleep Apnea.

[P E O P L E]
[P R O D U C T S]
[P R O G R A M S]



RESPIRONICS®

1001 Murry Ridge Lane
Murrysville, Pennsylvania
15668-8550 USA

1021427
JH 10/15/04