



Technique de pesage



D410 Terminal



Use and maintenance manual

Index

1. GENERAL	1-5
1.1 Declaration of conformity	1-5
1.2 Foreword	1-6
1.3 Symbols	1-8
1.4 Documentation	1-9
1.5 Description of the terminal	1-9
1.6 Technical characteristics of the terminal	1-10
1.7 Dimensions and weight of the terminal	1-11
1.8 Obtaining technical assistance	1-13
1.9 Replacement parts list	1-14
1.10 Warranty	1-14
2. SAFETY INSTRUCTIONS	1-15
2.1 Prohibited uses	1-15
2.2 Regulations	1-15
2.3 Prescriptions of use	1-15
3. DELIVERY AND INSTALLATION	1-17
3.1 Connection of the terminal to the electrical supply line	1-18
3.2 Connection of the terminal to the platform scale	1-19
3.2.1 Equipotentiality between the terminal and the platform scale	1-20
3.2.2 Connection of analogue load cells	1-20
3.2.3 Connection of digital load cells	1-21
3.3 COM1 serial port connection	1-22
3.4 COM2 serial port connection	1-23
3.4.1 Connection of COM2 in RS232 configuration	1-23
3.4.2 Connection of COM2 in RS422 configuration	1-24
3.4.3 Connection of COM2 in RS485 configuration	1-25
3.5 Analogue output connection	1-26
3.6 Input/Output connection	1-27
4. CONTROLS, DISPLAY, SWITCHING THE TERMINAL ON AND OFF	1-29
4.1 Display of weight and additional information	1-29
4.1.1 Selection display symbols	1-30
4.2 Weighing function keys	1-31
4.3 Alphanumeric keys	1-33
4.4 Switching the terminal on and off	1-34
5. USE OF THE TERMINAL	1-37
5.1 General	1-37
5.1.1 Using the keys to navigate the menus	1-37
5.1.2 Entering numeric data (Editor)	1-38
5.1.3 Entering alphanumeric data	1-38
5.1.4 Shortcut keys	1-40
5.2 User menu	1-40
5.2.1 User menu tree	1-40
5.2.2 Adjusting the contrast	1-42
5.2.3 Changing the date and time	1-42
5.2.4 Weight display	1-42
5.2.5 Memory status	1-45
5.2.6 Reprint	1-45

5.2.7	Diagnostics (for digital scale only)	1-45
5.2.8	Setting the outputs as Setpoints (if enabled)	1-46
5.2.9	Setting the outputs as ranges (if enabled)	1-46
5.2.10	Generic code	1-46
5.2.11	Product code	1-47
5.2.12	Product code list	1-47
5.2.13	Preset tares	1-48
5.2.14	Preset tare list	1-48
5.2.15	Progressive number	1-49
5.2.16	Coefficient Management	1-49
5.2.17	Totals management	1-50
5.3	Printing weighing data	1-52
5.3.1	Weighing data reprint	1-53
5.4	Operating modes	1-54
5.4.1	Standard operation	1-54
5.4.2	Sum weighing operation	1-54
5.4.3	Loading extraction operation	1-54
5.4.4	Unloading extraction operation	1-55
5.5	MPP operation	1-55
6.	OPTIONS	1-57
6.1	4 I/O board	1-60
6.2	BCD parallel 5V	1-61
6.3	Calculator BCD	1-63
6.4	Parallel 24V source current BCD (positive common)	1-65
6.5	Serial port expansion board	1-68
6.6	MPP memory expansion boards	1-71
6.6.1	Memory capacity	1-71
6.6.2	Operation	1-71
6.6.3	Disabling MPP	1-72
6.6.4	Checking memorised weight data	1-73
6.7	12-24Vac-dc input power supplier	1-74
6.8	Printers	1-76
7.	MAINTENANCE	1-77
7.1	Battery	1-77
7.2	Changing the fuses	1-77
8.	TROUBLESHOOTING	1-79
8.1	Malfunctions	1-79
8.2	Error messages	1-80

1. GENERAL

1.1 Declaration of conformity

DECLARATION OF CONFORMITY	
Manufacturer:	SOCIETÀ COOPERATIVA BILANCIATI
Address:	Via S. Ferrari, 16 41011 Campogalliano (MO)- Italy
declares that the product	
electronic terminal model:	D410
with the options	all those described in this manual
conforms to:	
☐ standards EN45501, EN50081-1 in accordance with the requirements of Directive 89/336 EEC (electromagnetic compatibility)	
☐ standard EN60950 in accordance with the requirements of Directive 73/23 EEC (low voltage directive)	
The terminal is also suitable for the creation of approved non-automatic weighing instruments with "CE Type Approval Certificate" in conformance with the requirements of Directive 90/384 EEC.	
The product bears the CE marking.	
Campogalliano, 24 July 2000	
Technical Director Eng. Luciano Diacci	

Declaration drafted in conformance with EN45014.

1.2 Foreword

- ☞ The aim of this manual is to provide the operator, through the use of text and illustrations, with essential information regarding the installation, safe operation and maintenance of the weighing system.
- ☞ This manual must be kept in a safe place where it is readily available for consultation. Always observe the instructions contained in the manual!
- ☞ The safe operation of the system is the responsibility of the operator, who must have a thorough knowledge of the system.
- ☞ The user is responsible for ensuring that the installation conforms to the applicable regulations.
- ☞ The equipment must be installed by specialised personnel who have read and understood this manual.
- ☞ "**Specialised personnel**" means any personnel who, by virtue of the training they have received and their professional experience, have been explicitly authorised by the "System safety supervisor" to install, operate and maintain the system.
- ☞ In the event of any problems, contact your nearest Service Centre.
- ☞ Any attempt on the part of unauthorised personnel to dismantle or modify the terminal is prohibited; any such attempt shall invalidate the warranty and release the manufacturer from all liability for any injury or damage.
- ☞ The alteration or removal of the data plates and seals is strictly prohibited; check that all plates and seals are present and legible, if not contact After-Sales Service.
- ☞ The manufacturer shall not be liable for any damages caused by incorrect handling of the terminal.
- ☞ The information and illustrations contained in this manual were up to date at the time of publication.
- ☞ The Manufacturer is committed to a policy of continuous product improvement and system components may therefore be subject to modification.
- ☞ All the technical information contained in this manual remains the exclusive property of the manufacturer and may not be divulged to third parties.
- ☞ No part of this document maybe reproduced or transmitted in any

form, including publication in computerised form or on the World Wide Web, without the express written permission of the manufacturer.

- ☞ This manual may not be used for purposes other than those directly related to the installation, operation and maintenance of the terminal.
- ☞ In order to more clearly illustrate certain maintenance or adjustment operations, some of the illustrations in this manual show the weighing system with the safety guards removed. Under no circumstances may the system be operated in these conditions. Do not operate the system in these conditions under any circumstances whatsoever, but remove the safety guards for the time strictly required to carry out the required repairs or maintenance then fit them back in place.

1.3 Symbols

Below is a list of the symbols used in this manual to alert the reader to the various hazards associated with the operation and maintenance of the instrument.



Denotes an operation or procedure where failure to observe the instructions will result in death or serious injury.



Denotes an operation or procedure where failure to observe the instructions could result in minor injury or damage to the instrument.



Information or instructions on how the system is to be operated correctly in order to maximise its service life or prevent loss or damage of programmed data or to optimise operation with regard to metrological standards.

Text and messages displayed on the terminal are printed in this manual using special characters.

Messages:

Display messages appear like this.

Menu pathways:

2°F>OTHER>MENU>Contrast.

The character > indicates the transition from one menu option to the next.

1.4 Documentation

This manual is accompanied by a CD-ROM that primarily contains information about the installation of the terminal.

Here you will find information on how to interface the terminal with a PC and PLC.

1.5 Description of the terminal

The model D410 digital weight indicator allows highly accurate and reliable weighing. This terminal is designed to facilitate dialogue with the operator through the alphanumeric keypad and graphic display, which, in addition to being extremely easy to use, has facilities for changing the shape and size of the display characters to suit various conditions of use. The D410 terminal provides a wide range functions, which, combined with the possibilities for expansion, allow for easy interfacing with external equipment.

Some of the main features of the terminal:

- ☞ facility for connection to a scale with analogue load cells (up to 12 x 350 ohm load cells)
- ☞ facility for connection to a scale with digital load cells (up to 12 CPD load cells)
- ☞ two RS232/422/485 serial ports
- ☞ analogue output of 0-10V or 0(4)-20 mA
- ☞ 2 inputs and 2 relay outputs
- ☞ 110/230 Vac power
- ☞ specific operating modes that can be selected by the operator
- ☞ facility for connection to a tally roll printer, document printer or labelling machine
- ☞ management of totals files associated with alphanumeric codes
- ☞ quick customisation of keypad and messages

1.6 Technical characteristics of the terminal

Power supply	85-265 Vac 50/60 Hz
	12-24 Vdc (optional)
Maximum power:	50 W
Load cell connection:	up to 12 analogue load cells of 350 ohm via 9-pin D-type connector
	up to 12 CPD digital load cells via 15-pin D-type connector
Minimum impedance:	29 ohm
Analogue load cell power:	10 Vdc
Digital load cell power:	10 - 18 Vdc
Internal resolution:	500000 points @ 25 conv/sec
	120000 points @ 100 conv/sec
Resolution in type-approved version:	10000 divisions maximum
Maximum input signal:	23 mV
Sensitivity:	0.75 uV/division (version with analogue load cells)
Full scale stability:	< 5 ppm/°C
Zero stability:	< 5 ppm/°C
Compensated temperature range:	-10 + 40 °C
Operating temperature range:	-10 + 50 °C
Protection class:	IP20
Humidity:	85 % @ 40°C

D410

Analogue output:	0 - 10 V (minimum load 100 kohm)
	0 (4)-20 mA (maximum load 250ohm)
Analogue output resolution:	10000 points
Analogue output precision:	0.05 % FS
Output contacts:	mechanical contact
Switchable voltage:	110 Vac/dc maximum
Switchable current:	200 mA maximum

1.7 Dimensions and weight of the terminal

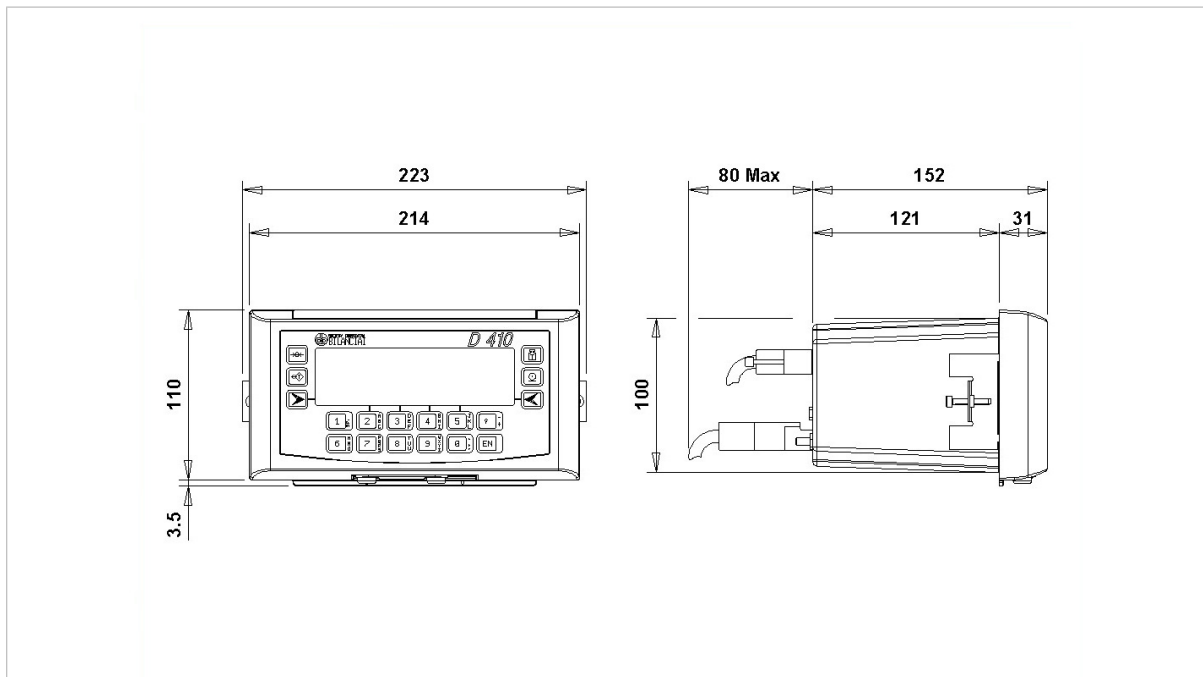

Weight: 2 Kg

Dimensions of panel space for rack mounting: 200 mm x 104 mm (base x height)

The dimensions are given in mm.

Figure 1.1 - Dimensions and weight of rack-mounted version
(cbd0010.jpg)

D410

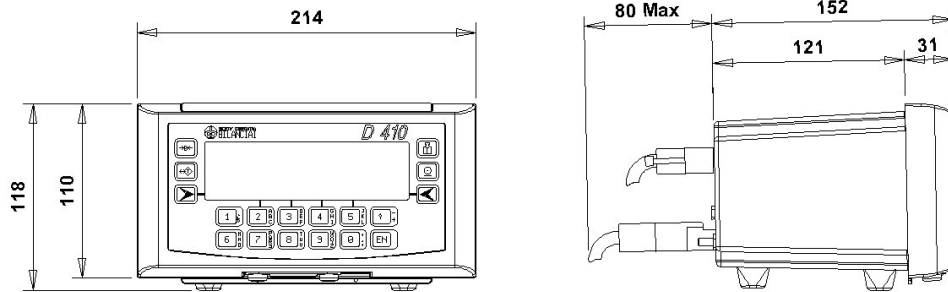

Weight: 2 Kg

The dimensions are given in mm.

Figure 1.2 - Dimensions and weight of table top version
(cbd0009.jpg)

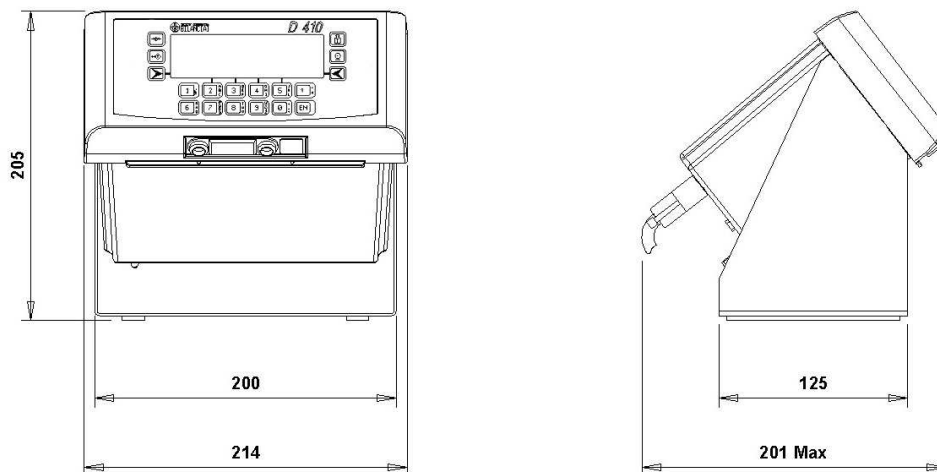

Weight: 2.5 Kg

The dimensions are given in mm.

Figure 1.3 - Dimensions and weight of version with tilted support
(optional) (cbd0012.jpg)

1.8 Obtaining technical assistance

In the event of any operating faults requiring the intervention of specialised technicians, contact the manufacturer or your nearest Service Centre. To enable us to deal with your request swiftly, always quote the serial number of your terminal, which can be found on the seal label. Also provide information about the system in which the terminal is installed.

1.9 Replacement parts list

Replacement parts can ordered directly from the manufacturer or from your nearest Service Centre.

Code	Description
460727	Series D400/800 110/230 Vac power supplier
460740	Power supplier series D400/800 12-24Vdc-ac
290389	D410 keypad
403941	CPU board
460728	Converter for analogue load cells
403961	Interface or digital load cells
403981	MPP FLASH memory expansion board
403991	Serial expansion board
404001	4 inputs/4 outputs board
404011	BCD TTL or calculator board
404012	BCD 24V source board
527313	Battery
460729	Display

1.10 Warranty

The conditions of warranty are stipulated in the contract of sale.

2. SAFETY INSTRUCTIONS

2.1 Prohibited uses

The instrument you have purchased is a weighing system and has been designed and manufactured as such. The instrument is primarily intended for the weighing of goods.

- ☞ It is forbidden to use the terminal without taking the necessary precautions for safe use.
- ☞ Use of the terminal in places with potentially explosive atmospheres or in areas where there is a risk of fire is strictly prohibited.

Any other use shall only be permitted if expressly authorised by the Manufacturer.

2.2 Regulations

The operating conditions for the electronic terminal are subject to the regulations in force in the country in which the terminal is used. All use of the terminal in conditions which do not comply with these regulations is prohibited.

2.3 Prescriptions of use

- ☞ Strictly comply with the instructions in this manual during use.
- ☞ In the event of any discrepancy between the information in this manual and the instrument purchased, contact your Dealer or the Manufacturer's After-Sales Service for clarification.
- ☞ Always observe the indications given on the warning and danger plates on the terminal.
- ☞ Check that all the safety guards are in place and that the connection cables are in good condition and connected correctly.
- ☞ Check that the terminal is connected to an electrical outlet socket equipped with an effective earth connection. Make sure that the line complies with the applicable regulations. Check that there is no difference in potential between the earth and neutral conductors.
- ☞ If the terminal is to be connected to other devices (e.g. a computer), these devices must be disconnected from the electrical supply before connection to the terminal.

- ☞ All maintenance and/or repairs must be carried out by authorised personnel only.
- ☞ Always disconnect the terminal from the electrical supply and wait a few minutes before accessing the internal components.

3. DELIVERY AND INSTALLATION

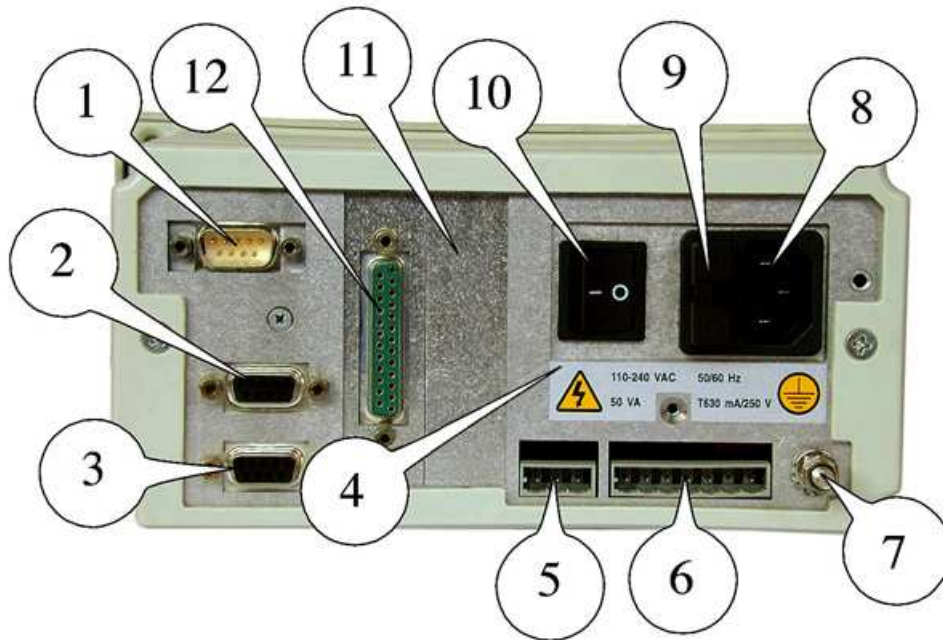

Key

1. 9-pin male connector (JBIL) for platform scale connection (15-pin male for digital load cells)
2. 9-pin female serial port connector (JCOM 1) for printer connection
3. 9-pin female serial port connector (JCOM 2) for connection of various devices
4. Data plate indicating voltage, frequency and fuse types
5. Analogue output connection terminals (JVI)
6. Input/Output connection terminals (JI/O)
7. Earth screw
8. Male 3-pin connector for power supply connection
9. Fuses
10. ON/OFF switch
11. Expansion slot 2
12. Expansion slot 1

Figure 3.1 - Rear of terminal (log0103.jpg)

3.1 Connection of the terminal to the electrical supply line



Check that:

- ☞ The voltage and frequency of the electrical supply line corresponds to the indications on the warning plate on the rear of the terminal (see point 4 Figure 3.1 on page 1-17);
- ☞ the mains outlet socket to which the terminal is connected is equipped with an earth;
- ☞ the warning and danger signs are present and legible;
- ☞ failing this, notify your maintenance personnel or contact our Assistance Service directly;

For the correct connection of the terminal to the electrical supply line, proceed as follows:

- ☞ plug the 3-pin connector of the power lead into the connector on the rear of the terminal;
- ☞ insert the plug of the power lead into the correct mains outlet socket.

The terminal complies with the European Directive for electromagnetic compatibility, however it is good practice to provide a separate power supply line for the terminal.

 **WARNING** 

Do not route the terminal connection cables alongside power cables as these could cause disturbances that interfere with the correct operation of the terminal. Only use the connection cable supplied with the terminal. If the cable supplied is too short, do not attach an extension lead but contact the Manufacturer.

3.2 Connection of the terminal to the platform scale

The terminal is normally supplied with a pre-wired cable for connection to the platform scale. The female connector on this cable should be plugged into the male 9/15-pin connector (JBIL) on the rear of the terminal (see point 1 Figure 3.1 on page 1-17). The connection method may vary according to the type of transducer on the platform scale (analogue or digital).

 **WARNING** 

The cable screen should always be connected to the metal cap of the 9/15-pin connector. Do not route the scale connection cable alongside power cables.

3.2.1 Equipotentiality between the terminal and the platform scale

Check that a condition of equipotentiality exists between the metal parts of the terminal and the platform scale.

If in doubt, connect the terminal and the scale using a earth wire of at least 6mm² using the earth screw on the rear of the terminal (see point 7 Figure 3.1 on page 1-17).

The cables required for this connection are to be provided by the customer.

3.2.2 Connection of analogue load cells

The diagram below shows the pinout for the JBIL connector for connection to scales with analogue load cells.

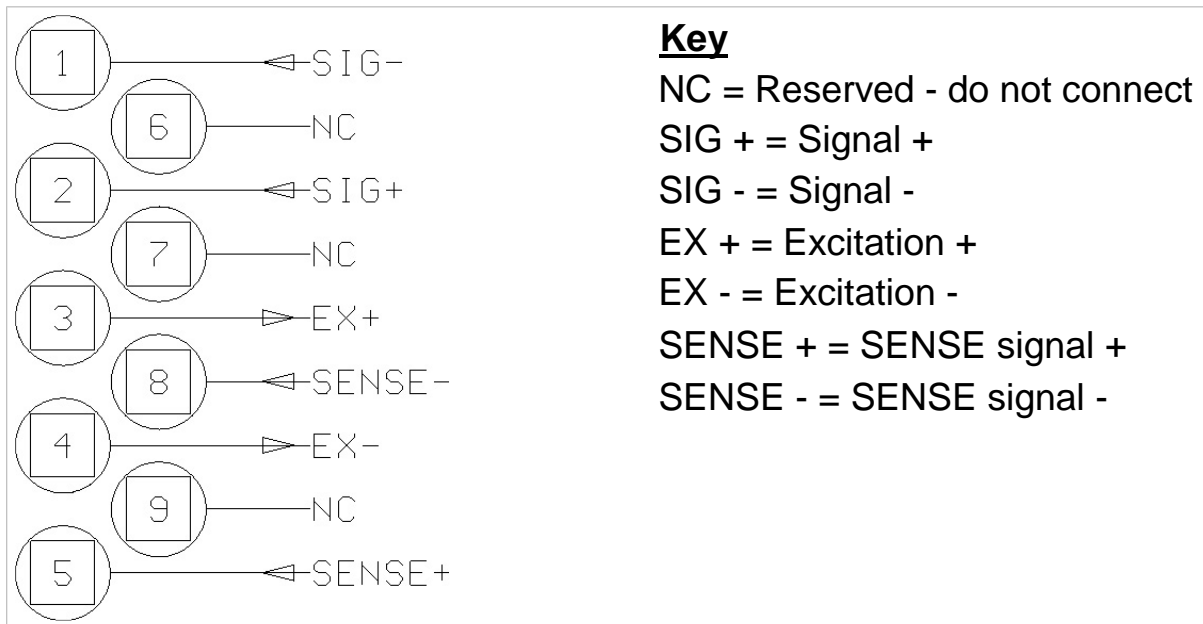

Figure 3.2 - Pinout for the JBIL connector for connection to scales with analogue load cells (log0001.gif)

3.2.3 Connection of digital load cells

Connection to digital load cells is by RS485 serial line using a screened cable with 6 conductors. The diagram below shows the pinout of the JBIL connector for connection to platform scales with digital load cells.

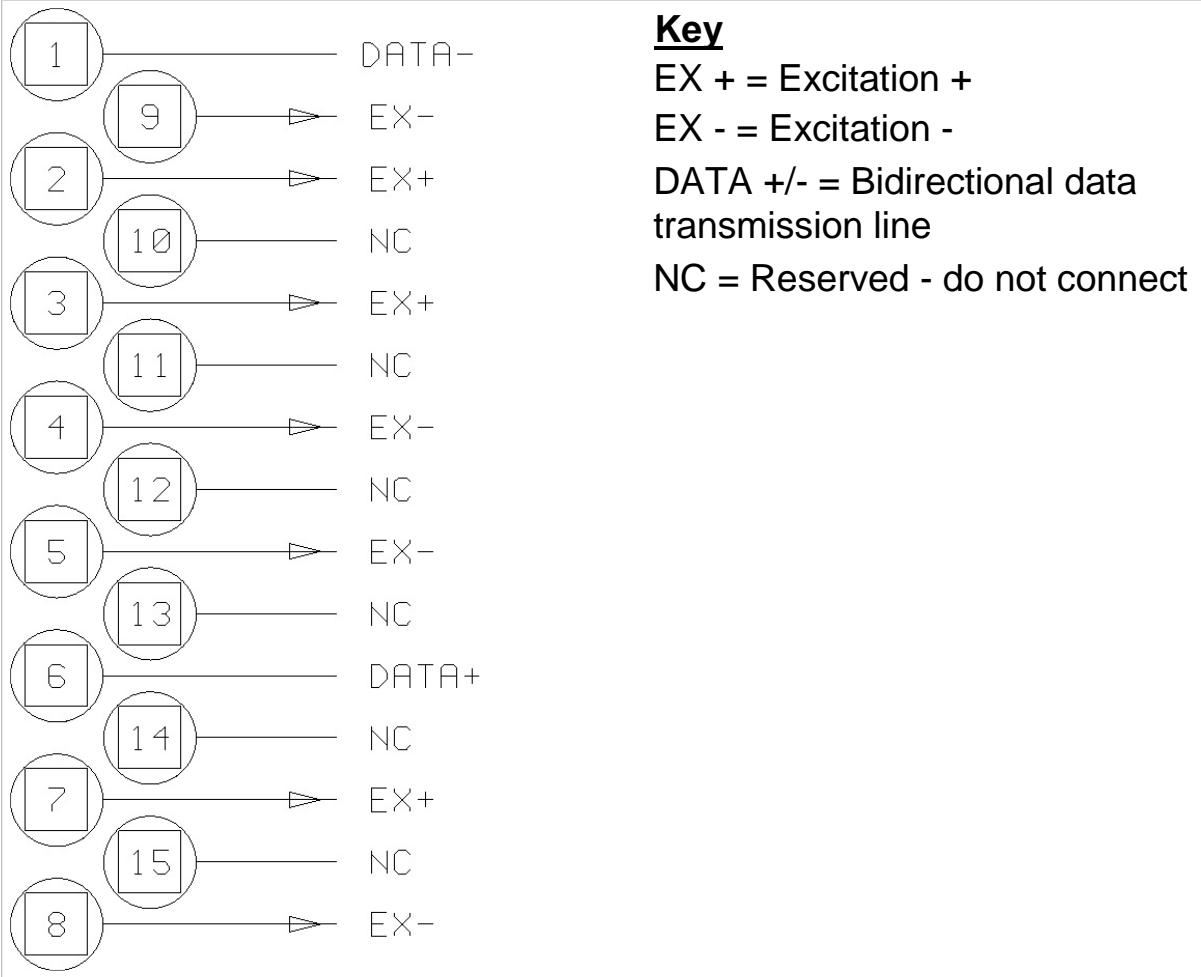

Figure 3.3 - Pinout of JBIL connector for connection to scales with digital load cells (log0002.gif)

Pins carrying the same signals may be connected in parallel.

3.3 COM1 serial port connection

The terminal has an RS232 serial port (COM1) with a 9-pin female connector located on the rear panel (see point 2 Figure 3.1 on page 1-17); the diagram below shows the pin connections for this port.

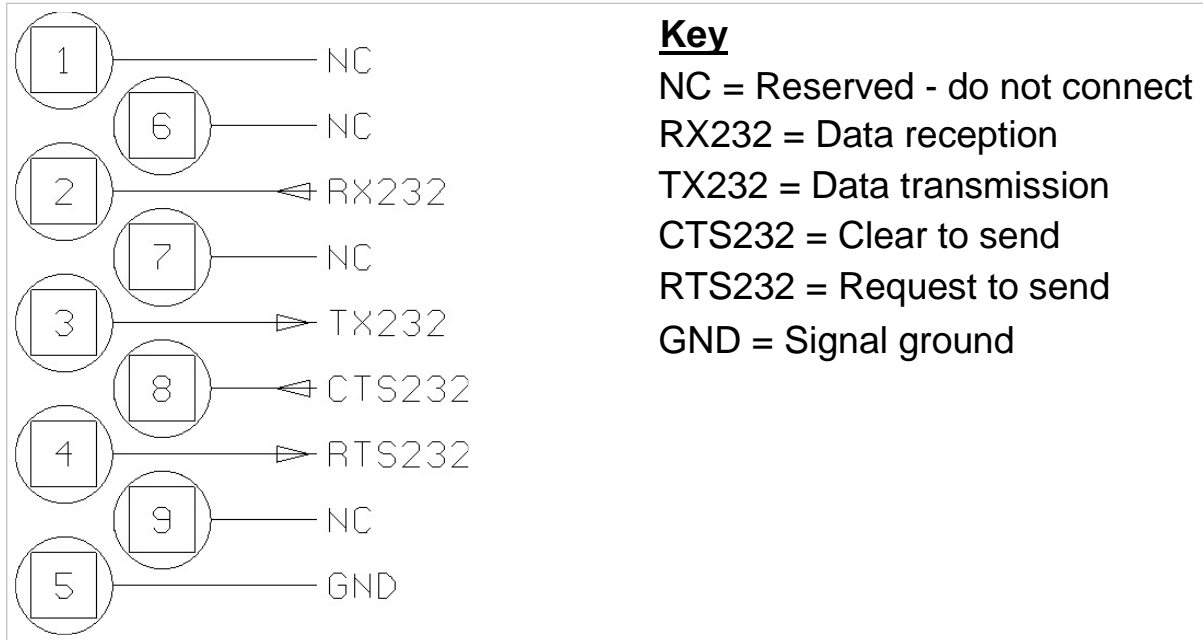

Figure 3.4 - Standard serial port connector (9-pin female D-type)
(log0003.gif)

⚠ CAUTION ⚠

Operating limits stipulated by the standard RS232:

Maximum transmission distance = 15 m

Maximum line voltage = ± 12 Vdc

For connection to external devices, use a screened cable and connect the screen to the metal cap of the 9-pin connector.

3.4 COM2 serial port connection

The terminal has second serial port, which can be configured for RS232, RS422 or RS485 data transmission standards. The serial port (COM2) has a 9-pin female connector (see point 3 Figure 3.1 on page 1-17).

3.4.1 Connection of COM2 in RS232 configuration

For the connection of external devices, refer to the pinout diagram in Figure 3.5 on page 1-23 :

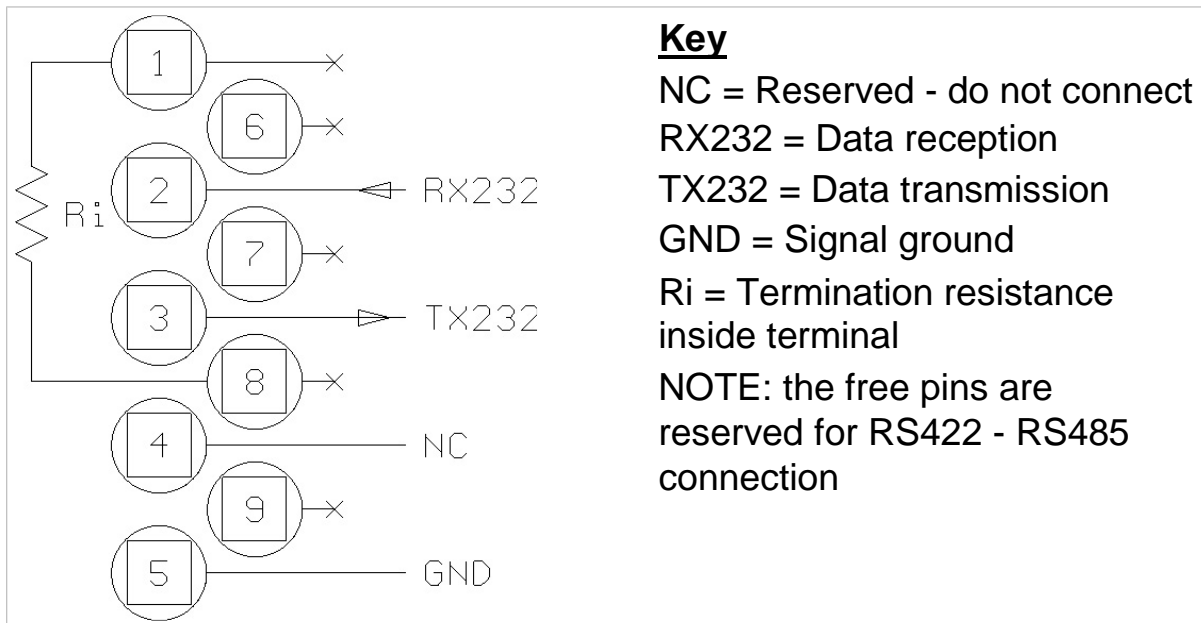

Figure 3.5 - COM2 serial port connector (9-pin female D-type)
(log0004.gif)

CAUTION

The RS232 operating limits are indicated in par. 3.3 on page 1-22 .

3.4.2 Connection of COM2 in RS422 configuration

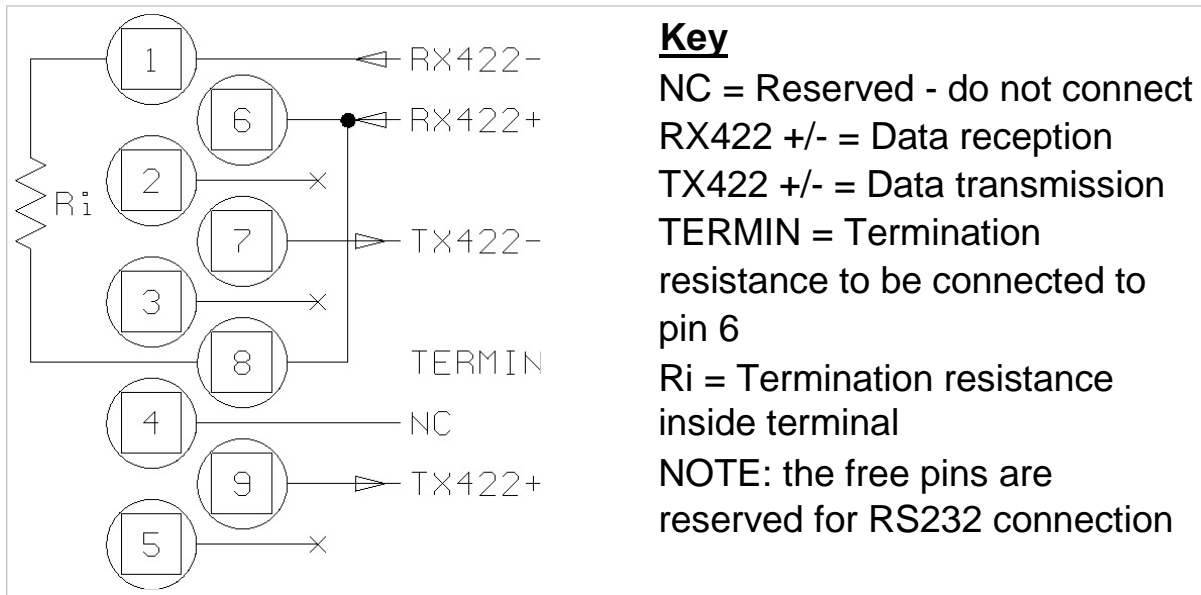

Figure 3.6 - Example of RS422 serial port connection (log0005.gif)

CAUTION

Operating limits stipulated by the standard RS422:

Maximum transmission distance = 1200 m

Maximum line voltage = +/- 7V

For connection to external devices, use a screened twisted pair cable and connect the screen to the metal cap of the 9-pin connector.

3.4.3 Connection of COM2 in RS485 configuration

If the COM2 serial port is configured for RS485 data transmission, you will need to:

- connect together pins 9 and 6 and pins 1 and 7 (Figure 3.7 on page 1-25)
- place a jumper across pin 6 and pin 8 to connect the termination resistance; this operation is to be carried out on the first and last terminals connected in the line

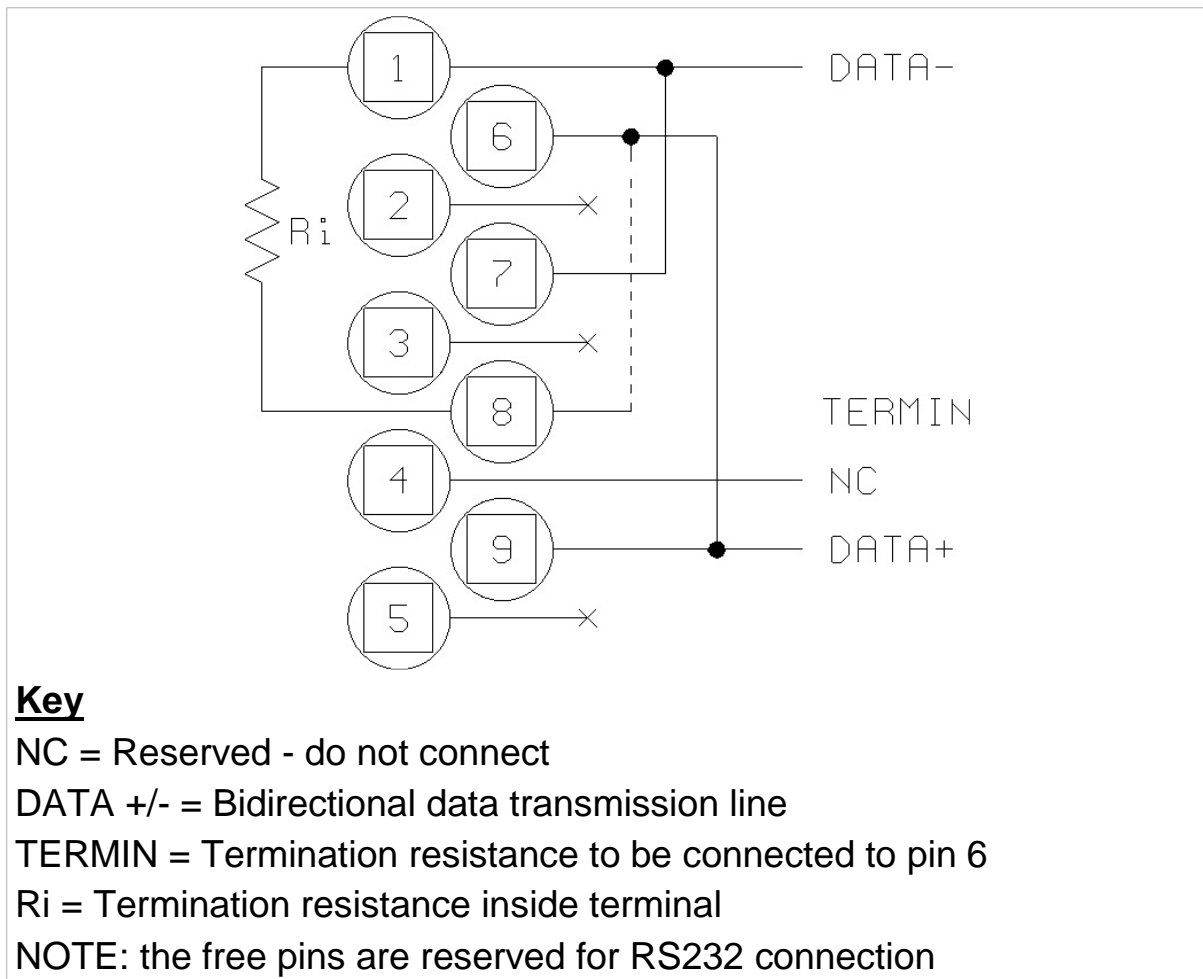

Figure 3.7 - Pinout for RS485 serial port connection (log0006.gif)

CAUTION

Operating limits stipulated by the standard RS485:

Maximum transmission distance = 1200 m

Maximum line voltage = +/- 7V

For connection to external devices, use a screened twisted pair cable and connect the screen to the metal cap of the 9-pin connector.

Maximum number of terminals that may be connected = 16

3.5 Analogue output connection

The connector JVI located on the rear of the terminal (point 5 Figure 3.1 on page 1-17) provides an analogue output in the forms 0-10 V and 0(4)-20 mA galvanically separated; the connection pinout is given in the following table.

Pin n°	Signal
1	Output 0-10 V
2	Output 0(4)-20 mA
3	Common

⚠ CAUTION ⚠

Technical characteristics:

Resolution= 10000 points

Precision = 0.05 % FS

Minimum voltage output load = 100 kohm

Minimum current output load = 250 ohm

3.6 Input/Output connection

The terminal board JI/O on the rear of the instrument (point 6 Figure 3.1 on page 1-17) provides input and output contacts; Figure 3.8 on page 1-27 contains the pinout diagram.

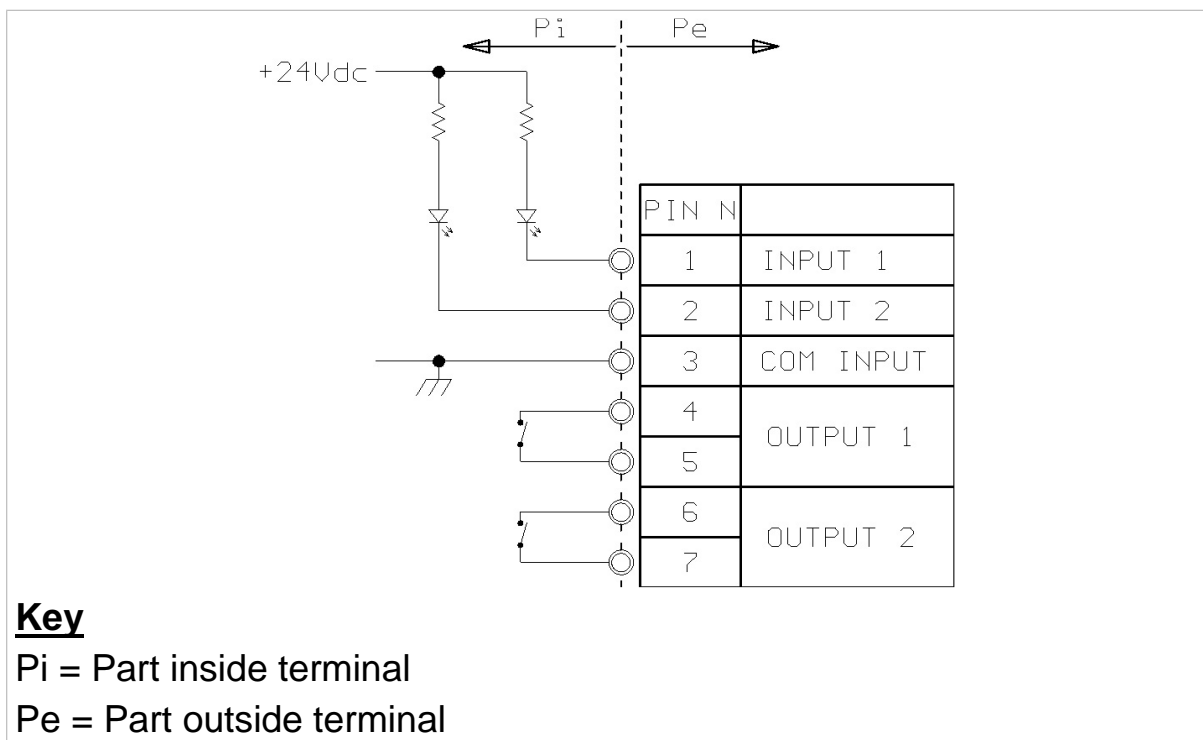

Figure 3.8 - JI/O terminal board for Input/Output connections
 (log0008.gif)

 **CAUTION** 

Technical characteristics:

Input:

Maximum input voltage = 24Vdc

Maximum input current = 5mA

The inputs can be controlled by a mechanical contact or by an NPN-type transistor (negative common)

Output:

mechanical voltage-free contact

Maximum switchable voltage = 110 Vac/dc

Maximum switchable current = 200 mA

I/O refresh time = 1/10 s

 **DANGER** 

When the weighing system is installed in complex plants that can represent a danger hazard for operators, enlist the assistance of specialised personnel to perform several manoeuvres without load in order to acquire the experience necessary to work in safety.

4. CONTROLS, DISPLAY, SWITCHING THE TERMINAL ON AND OFF

4.1 Display of weight and additional information

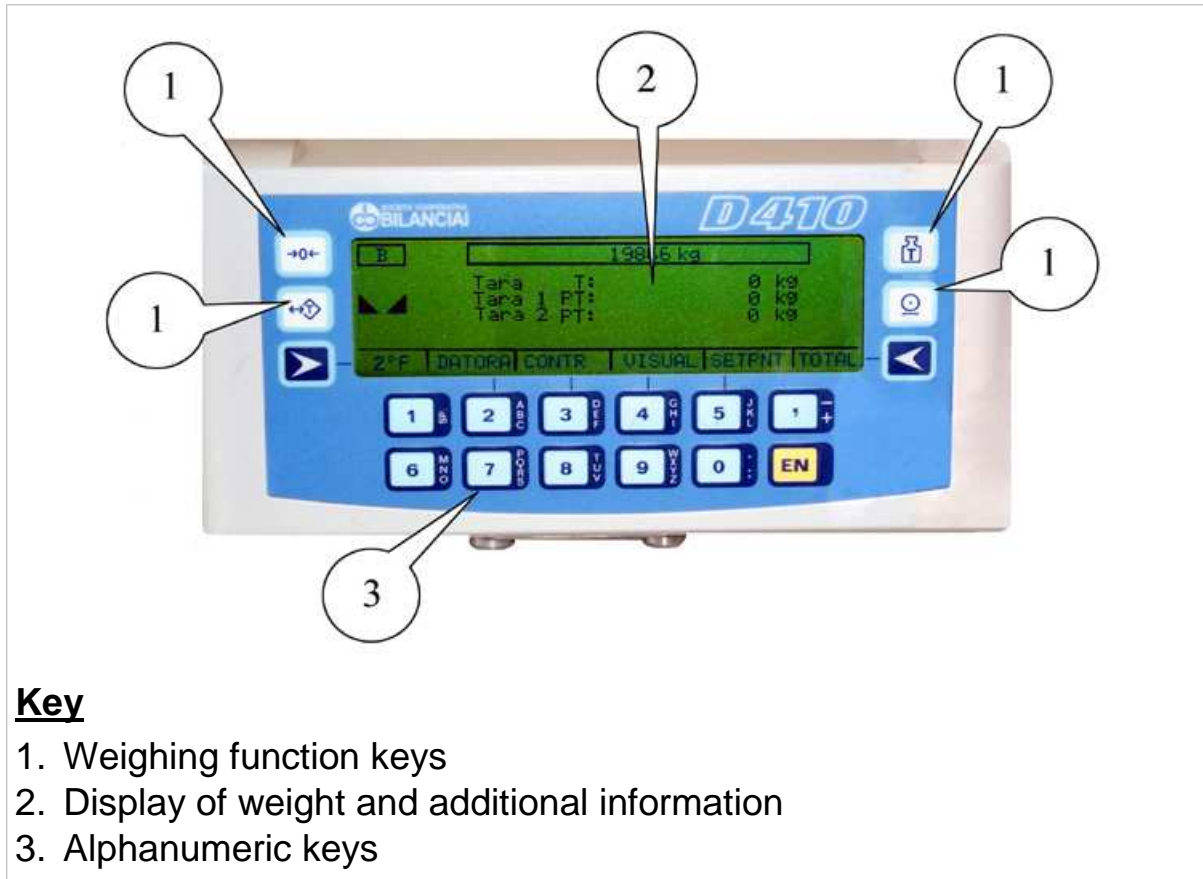

Key

- 1. Weighing function keys
- 2. Display of weight and additional information
- 3. Alphanumeric keys

Figure 4.1 - Front of terminal (log0127.jpg)

The LCD (Liquid Crystal Display) (point 2 Figure 4.1 on page 1-29), in addition to the universally recognised weighing symbols, also displays information (in extended format) related to the operation of the terminal.

Listed below are the weighing symbols displayed and their meanings:



Weight stable symbol

Indicates that the weight value displayed is stable and thus may be printed and/or transmitted.



Centre zero symbol

Indicates that the weight on the scale is near to zero i.e. within $-1/4 + 1/4$ of a division.



Tare symbol

Indicates the presence in memory of an acquired tare value.



Preset tare symbol

Indicates that a tare value has been entered from the keypad.



Gross weight symbol



Gross weight symbol with units of measurement in lb (as alternative to B)

This symbol only illuminates when the unit of measurement is "lb" (pounds).



Minimum weight



Net weight symbol



Weighing range indication for multi-extension (ME) instruments

4.1.1 Selection display symbols

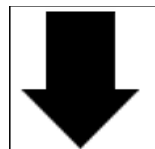

Weight indication

Below preset lower limit.

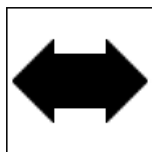

Weight indication

Within the preset upper and lower limits.

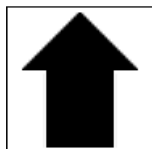

Weight indication

Above the preset upper limit.

4.2 Weighing function keys

Refer to point 2 of Figure 4.1 on page 1-29 :



Zero-set weight

pressing this key resets the weight indication only if the following conditions are satisfied:

- ☐ the weight value must be within the $-1\% \div +3\%$ range of the weighing capacity for terminals subject to legal verification or $\pm 50\%$ for other terminals;
- ☐ the weight must be stable;
- ☐ no tare must be entered.



Enter/cancel tare

On pressing this key, the weight on the scale is acquired as the tare value, provided the following conditions are satisfied:

- ☐ the weight must be stable;
- ☐ the weight must have a positive value;
- ☐ the weight must not exceed the maximum capacity.

The display illuminates the symbols **NET** and



.
On MD terminals, the weight indication will be displayed using the division of the lower range. On ME terminals, the net weight will be displayed using the division of the range in which it falls.



On pressing  again, the tare will be cancelled and the terminal resumes display of the gross weight.



Enter/display tare

Pressing this key allows you to enter a tare value using the numeric keys on the keypad (par. 4.3 on page 1-33). To change a preset tare value see par. 5.2.13 on page 1-48 .

On completion of the operation, the display will show the net weight and tare values and illuminate

the symbols **NET** and  . The entered tare value will be automatically rounded off to the nearest scale division. On MD terminals, the net weight will be displayed using the division of the range within which the net weight value falls, while on ME terminals, the net weight division shall be that of the range within which the gross weight falls. On MD terminals, the maximum preset tare value is limited to the maximum capacity of the first weighing extension (indicated on the metrological data plate).



Print and/or send

Allows a weighing option to be requested. Consequently forces a weighing data printout and/or serial transmission of a string of data via the configured port.



Customizable keys

The functions associated with these keys are indicated on the display.



4.3 Alphanumeric keys

Refer to point 3 of Figure 4.1 on page 1-29 :

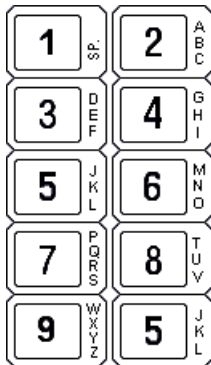

Keys for entering numeric values and alphanumeric characters

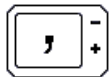

Key for entering decimal digits

Use this key for entering decimal values.



Enter or confirm

Press to confirm an operation.



The function of the keys



may vary and are indicated on the display.

4.4 Switching the terminal on and off

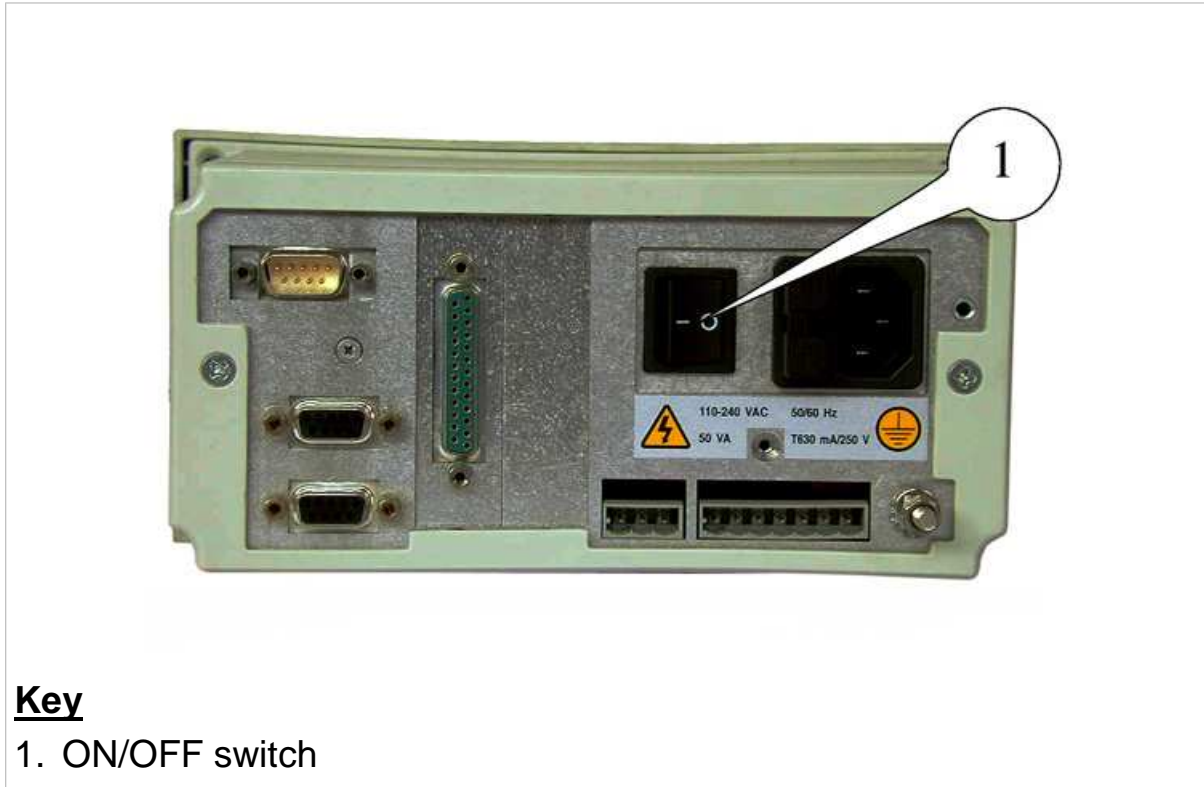

Key

1. ON/OFF switch

Figure 4.2 - On/Off switch (log0105.jpg)

⚠ DANGER ⚠

Before switching on the terminal, check that the safety guards are in place and in good working order.

If the terminal is wall mounted on an electrical panel, there must be a main switch that disconnect powers to the entire panel.

To identify this switch, contact your internal maintenance manager.

Press the switch on the rear of the terminal (see point 1 Figure 4.2 on page 1-34) to position:

- I to switch on the terminal;
- O to switch it off

On power on, the display will show the Manufacturer's logo and the type of operation for which the terminal is enabled (see par. 5.4 on page 1-54).

Wait for the LOCK indication to appear (terminals subject to metrological verification only).

If on completion of the operation the display shows a value other than

zero , press  to zero-set the reading.







If the display is not zero-set on pressing the key:

- ☞ check that the platform scale is in fact unloaded. If not, unload the scale, switch off the terminal and then switch it on again;
- ☞ If the problem persists, contact your Service Centre.

5. USE OF THE TERMINAL

5.1 General

5.1.1 Using the keys to navigate the menus

The numeric keys     described in par. 4.3 on page 1-33 and the customisable keys  e  par. 4.2 on page 1-31 can be used to navigate the programming menus.

From the normal weight display condition, you can access the menus by

pressing  to select the option 2°F. Now use the other keys to select the next option. A maximum of 6 functions are available on the bar of the shortcut keys. By pressing the key in correspondence with the indication OTHERS you can switch to other functions managed by the terminal. The arrow keys ↑, ↓, →, ← allow you to move respectively up, down, right and left.

By pressing SELECT you can select the required option or enter a submenu.

The keys # and \ allow you to change the way the menu pathway is displayed : # extended pathway, \ pathway expressed numerically. Selecting ESC returns you to the previous menu level. By pressing ESC repeatedly you can therefore exit through the menus to return to the normal weight display mode. From here on in this manual, the instructions will only indicate the pathway without referring to the specific keys to be pressed. For example, the instruction on how to change the contrast will be given as follows:

```
2°F>CONTR>+ ○ ->SAVE>ESC
```

5.1.2 Entering numeric data (Editor)

Numeric values may be entered as follows:

- ☞ select the function for which you wish to enter the value (preset tare, settings, range...); the display will show the selected function with the value currently stored in memory;
- ☞ enter the value using the numeric keys (par. 4.3 on page 1-33)
- ☞ press  to confirm the value and return to the previous menu.

5.1.3 Entering alphanumeric data

Alphanumeric data may be entered as follows:

- ☞ Select a function for which an alphanumeric value may be entered (e.g. the generic code);
- ☞ press the keys corresponding to the letters you want to enter;
- ☞ press  to confirm.

bear in mind that:

- ☞ pressing the same key repeatedly displays each of the letters, the number and the special characters associated with that key in sequence;
- ☞ to confirm the letter displayed, simply press, simply press another alphanumeric key;
- ☞ to enter two consecutive letters using the same key, wait a second before pressing the key again: the correct position will be indicated by the cursor;

 prolonged pressure on a key will display all the characters associated with that key. By moving left and right with the keys → and ← you can select the character you wish to enter. The selected character is displayed in reverse video. Confirm the selection by pressing OK. To toggle between upper and lower case letters, press the key in correspondence with the indication CAPIT/SMALL.

Below is a list of the characters associated with each key:

Alphanumeric keys	Characters
	, - + ; * / = % > <
	0 . : ? ! () ¿ ¡ ' "
	(blank) 1 £ \$ @ & °
	A B C 2 â ä à å Ä Å ç Ç
	D E F 3 è ê ë è É æ Æ
	G H I 4 ï î ï í
	J K L 5
	M N O 6 ô ö ò ó Ö ñ Ñ
	P Q R S 7 ß
	T U V 8 ü û ù ú U
	W X Y Z 9 ÿ

5.1.4 Shortcut keys

During installation, User menu functions may be assigned to shortcut keys. In this way the user can access the required function more rapidly. For example, to access the function `Product Code`, the user will not have to press

`...MENU>Data Management>Code Management>Product Code`

but simply press `PROCOD`

The abbreviations that appear on the display may be customised during installation. For this reason, the abbreviations related to the shortcut keys that appear in brackets alongside or below the pathways described in the following paragraphs may have been modified by the installer. Ask your installer for a list of the abbreviations and their meanings.

The pathways themselves may also vary according to the number of files and the shortcut keys assigned during installation. In this case the `MENU` key may be accessed by pressing `2°F` and `OTHERS`.

5.2 User menu

5.2.1 User menu tree

The User menu tree expanded to the third level is reported below. For details of the various functions, refer to the subsequent paragraphs (5.2.2 to 5.2.17).

Data management

- Codes management
 - Generic code
 - Product Code
 - Product Code List

Range

- Range 01
- Range 02
- Range 11
- Range 12
- Range 13
- Range 14
- Range 21
- Range 22
- Range 23
- Range 24

Setpoint

- Setpoint 01
- Setpoint 02
- Setpoint 11
- Setpoint 12
- Setpoint 13
- Setpoint 14
- Setpoint 21
- Setpoint 22
- Setpoint 23
- Setpoint 24

- Display MPP data

- Preset tares

 - Entering

 - Preset tares list

- Progressive N.

- Coefficient management

 - Coefficient

 - Operation

 - Rounding

Totals management

- General Total

- Partial Total

- Product Code Total

- Generic Code Total

MPP operation

- De-activated

- With memory

- With printer

Display

- 15mm digits

- 30mm digits

- Selection

- Extraction

- Display tare

Contrast

Memory status

Reprint

Date Time

Diagnostics

5.2.2 Adjusting the contrast

To adjust the contrast of the display, follow the pathway:

...>MENU>Contrast

(Shortcut key CONTR).

By pressing + or - you can adjust the contrast. To save the new setting in memory press SAVE .

5.2.3 Changing the date and time

Follow the pathway:

...>MENU>Date Time

(Shortcut key DATIME).

To change quickly from summer to winter time press + or - 1 hour, alternatively use the option CHANGE .

5.2.4 Weight display

You can change the way the weight value is displayed on the terminal. The current weight display mode will depend on the operation type set during installation (see par. 5.4 on page 1-54).

To select the display mode follow the pathway:

...>MENU>Display

(Shortcut key VISUAL).

The possible display modes are:

 15mm digits

The display shows the gross weight (or net) and the weighing symbols.

 30mm digits

The display shows the weight in 30 mm high digits and the weighing symbols.

Selection

In addition to the weight and the usual weighing symbols, the display

shows one of the following symbols    (see par. 4.1.1 on page 1-30).

To set the range, press **DRANGE** , select the values with **SELECT** and enter the numerical values using the number keys (par. 4.3 on page 1-33).



WARNING

The display range described here is independent of the range associated with the outputs (see par. 5.2.8 on page 1-46 and par. 5.2.9 on page 1-46).

Display tare



In addition to the usual weighing symbols, the terminal can also simultaneously display the net weight and the tare (if present).

The following indications are displayed:

-  If a tare has been entered by pressing  and multiple tares were not set during installation:

Tare: tare value + unit of measurement

The indications **NET** and PT will be illuminated.

-  If the tare was acquired by pressing  and multiple tares have not been set:

Tare: tare value + unit of measurement

The indications **NET** and T will be illuminated.

-  If the tare is preset (par. 5.2.13 on page 1-48 and multiple tares have not been set:

Tare C: preset tare value + unit of measurement

The indications **NET** and PT will be illuminated.

NOTE: the indication Tare C indicates that the tare displayed is a "coded" tare to which a numerical code has been assigned (par. 5.2.12 on page 1-47).

☰ If multiple tares were set during installation:

Tare T: acquired tare value + unit of measurement
Tare 1 PT: preset tare 1 value + unit of measurement

Tare 2 PT: preset tare 2 value + unit of measurement

Or

Tare C PT: preset tare value + unit of measurement

Tare 1 PT: preset tare 1 value + unit of measurement

Tare 2 PT: preset tare 2 value + unit of measurement

Or

Tare PT: "non coded" tare value + unit of measurement

Tare 1 PT: preset tare 1 value + unit of measurement

Tare 2 PT: preset tare 2 value + unit of measurement

The indications **NET** and PT will be illuminated.

NOTE: Tare 1 and Tare 2 may also be recalled via numeric code (par. 5.2.13 on page 1-48).

☰ Extraction

This display mode is only possible if loading or unloading extraction operating mode is selected (see par. 5.4.3 on page 1-54 and par. 5.4.4 on page 1-55).

The display shows the gross weight, the extracted weight and the weighing symbols.

5.2.5 Memory status

If there is insufficient free memory, memory can be recovered by following the pathway:

...>MENU>Memory status

CAUTION

The memory recovery operation may require a few minutes during which time the terminal cannot be operated. Do not switch off the terminal during this operation as this could result in the loss of the data in memory.

5.2.6 Reprint

See par. 5.3.1 on page 1-53 .

5.2.7 Diagnostics (for digital scale only)

This user menu item is only available when there are digital cell errors (par. 8.2 on page 1-80). It allows you to identify what caused the error. Follow this path:

...>MENU>Diagnostics

If the instrument is not subject to calibration checks, CONT can be pressed to display the measured weight despite the error.

Remember that this can only be done in the case of serial number errors or ones due to non-configured digital cells.

The error message will reappear when the terminal is powered again unless the cause of the error is eliminated.

5.2.8 Setting the outputs as Setpoints (if enabled)

The two available outputs may be used in setpoint mode. In this way, the output is activated when the weight reaches the set value.

...>MENU>Data management>Set Point

(Shortcut key SETPNT).

Enter the required weight values as described in par. 5.1.2 on page 1-38 .

5.2.9 Setting the outputs as ranges (if enabled)

The two available outputs may be used in Range mode. The output is activated when the weight is within the set range; to set the range, follow the pathway:

...>MENU>Data management>Range

(Shortcut key RANGE).

5.2.10 Generic code

This is an alphanumeric code with a maximum of 8 characters that can be printed and/or transmitted. The maximum of codes that can be entered varies according to the other types of data managed. To enter a generic code follow the pathway:

...>MENU>Data management>Code management>Generic code

(Shortcut key GCCOD).

Enter the alphanumeric code as described in par. 5.1.3 on page 1-38 . If the value of the generic code = empty space, it will no longer appear in the printout and will not be used for totalization.

5.2.11 Product code

The terminal provides functions for the management of product codes, each of which may be associated with an alphanumeric description that can be printed and/or transmitted along with the weight. The product code is a numeric code with a maximum of 6 digits, while the alphanumeric description may be up to 20 characters long. The maximum of codes that can be entered is defined in the installation phase. It is variable and depends on which other data need to be managed.

To enter a product code, follow the pathway:

```
...>MENU>Data management>Code management>Product code  
(Shortcut key PROCOD ).
```

Enter the product code and the alphanumeric description as described respectively in par. 5.1.2 on page 1-38 and par. 5.1.3 on page 1-38 . If the product code is set to 0 (zero) during weighing operations, it will be excluded from all totalization operations.

5.2.12 Product code list

By following the pathway:

```
...>MENU>Data management>Code management>Product code  
list
```

you can call up a product code and display the relative description. To call up a product code, press the key in correspondence with the

indication PROCOD , enter the numeric code and press  to confirm. If a printer is connected, by pressing the key in correspondence with the indication SUMMAR , you can print the data relative to a single product code or summary of all the product codes within the range specified by the operator.

5.2.13 Preset tares

In addition the management of tares acquired from the weight present on the scale and tares entered from the keypad, the terminal also manages an archive of preset tares containing a number of values defined during the installation phase. Each value can be recalled by way of a 4 digit numeric code. Preset tares, once recalled by entering the relative code, are automatically subtracted from the weight on the scale. Preset codes may be entered by following the pathway:

...>MENU>Data management>Preset tare> Entering

(Shortcut keys `TAREC` and `TARCN` where $n= 1,2$ if multiple tares were set during installation)

Select the tare type, enter the code number and press  to confirm. If necessary, enter the tare value.

The value `TARE 2` can be multiplied by a number, designated the `Packs number`, which may be entered from the keypad to obtain a sum tare value (e.g. the sum of the tares of n containers of the same weight). The `Packs Number` can be entered directly from the shortcut key bar by pressing the key in correspondence to the indication `PACKSN`. The functions `TARE 1` and `TARE 2`, together with the `Packs Number`, allow weighing of products with both primary (e.g. pallets) and secondary (e.g. boxes) packaging.

5.2.14 Preset tare list

By following the pathway:

...>MENU>Data management>Preset tare>Preset tare list

you can call up a tare code and display the corresponding tare value. To recall a tare code, press the key in correspondence to the indication

`TAREC`, enter the numeric code and press  to confirm.

If a printer is connected, on pressing the key in correspondence to the indication `SUMMAR` you can print the data relative to a single tare code or a summary of all the tare codes within a specified range.

5.2.15 Progressive number

The terminal manages a 6-digit progressive number used to count the number of weighing operations performed: this value starts from 1 and is automatically increased by one unit after each print and/or weighing operation (and thus indicates the value of the next print or weighing operation). To change the progressive number, follow the pathway:

```
...>MENU>Data management>Progressive  
(Shortcut key PROG.N )
```

If the progressive number is set to 0 (zero), it will not be incremented and not be printed.

5.2.16 Coefficient Management

This function can be of use when the unit of measurement needs to be converted. for example, you can calculate the number of litres if the specific weight and overall weight of a liquid are known.

Follow the following path to access this menu:

```
...>MENU>Data Management>Coefficient Management  
(COEF rapid key)
```

Enter the required **coefficient**, then select the required type of **operation (multiplication or division)** and the **rounding** value for the result. This latter is just a numerical value without unit of measurement.

5.2.17 Totals management

The terminal provides functions for totalling the weighing data associated with the various codes. The totalization operation consists of adding the current weight value to the sum of the previous weights and increasing by one the number of weighing operations. To access the list of available totals, follow the pathway:

```
...>MENU>Totals management
```

(Shortcut key TOTALS)

General totals

These totalization functions provide general totals for the gross weight (if enabled during installation), net, tare and number of weighing operations independently of any associated codes. The data can be obtained using the following functions:

```
...>MENU>Totals management>General total
```

(Shortcut key GENTOT)

```
...>MENU>Totals management>Partial total
```

(Shortcut key PARTOT)

 PRINT prints selected value

 RESET resets the total

Totals by code

Saves the net weight values and number of weighments associated with a product code and generic code. The data can be accessed through the following functions:

...>MENU>Totals management>Product code total
(Shortcut key PROTOT)

...>MENU>Totals management>Generic code total
(Shortcut key GCTOT)

 PRINT prints the selected total

 SUMMAR prints the list of all the codes

 RESET resets the total



 PROCOD allows you to select another product code

 GCCODE allows you to select another generic code









5.3 Printing weighing data

The printer is normally connected to the terminal by way of the COM1 serial port (par. 6.8 on page 1-76).

Printouts are obtained by pressing . Printing is performed if:

-  the weight is valid, i.e. it is not less than zero and does not exceed the maximum scale capacity;
-  the weight is stable;
-  the printer is connected, switched on, there are no other print jobs currently in progress and there is paper in the printer.

The following data are printed:

-  Date and time (if enabled)
-  Progressive number
-  product code (if selected) with the relative alphanumeric description
-  Generic code (if selected)
-  Gross (if enabled)
-  Tare/s (if present)
-  Net
-  Coefficient and result (if enabled)

If the relative function is enabled, the product code and net weight may be printed in the form of a bar code.

The printout can be customised using a PC and a specific programme: for further information, contact your dealer.

For details regarding printing characteristics, paper format, printer maintenance etc., see the instruction manual for your printer.

5.3.1 Weighing data reprint

Access the `Reprint` item of the user menu to obtain the last printout again without having to change the consecutive number and any totals calculated.

The word `Copy` will appear on the reprint to distinguish it from the original.

5.4 Operating modes

The terminal operating mode is set during installation.

On switching on the terminal, the selected operating mode is displayed.

5.4.1 Standard operation



In standard operating mode, the terminal can acquire the gross (or net) weight on the scale and display it along with the weighing symbols. In this case, the possible display formats are 15mm digits, 30mm digits and Selection (see par. 5.2.4 on page 1-42).

5.4.2 Sum weighing operation

The sum weighing operating mode allows you to perform weighing operations in sequence without unloading the scale, zero-setting the net weight after each operation. To move from one weighing operation to the

next, press  when the weight is stable.

On completion of this operation:

-  thenet weight is zero-set and the weight currently on the scale is taken as the tare;
-  a string is sent to the serial port or the data is printed (if a printer is connected).

The display formats available in this operating mode are 15mm digits, 30mm digits and Selection (see par. 5.2.4 on page 1-42).

5.4.3 Loading extraction operation

This operating mode, when selected and associated with the I/O devices, allows you to perform simple dosing operations with a number of different components.

The I/O are selected during the installation phase.

Comply with the instructions in par. 5.2.8 on page 1-46 and enter the Set Point 01 and Set Point 02 values. Set Point 01 defines the final weight value to extract, Set Point 02 gives the weight value that, subtracted from the Set Point 01 value, marks the change from fast

extraction mode to slow extraction mode.

On pressing the key in correspondence with the indication `START` , the extracted weight value is zero-set and scale loading is enabled. The display shows the gross weight (the weight on the scale) and the extracted weight (the weight gradually loaded onto the scale).

The display format used in this operating mode is `Extraction` (see par. 5.2.4 on page 1-42).

The extraction operation can be concluded by pressing `STOP`.

5.4.4 Unloading extraction operation

This operating mode is identical to the previous mode except that in this case you start with a loaded scale and gradually remove material.

Enter the Set Point 01 and Set Point 02 values (par. 5.2.8 on page 1-46).

On pressing the key in correspondence with the indication `START` , the extracted weight value is zero-set and scale unloading is enabled. The display shows the gross weight (the weight on the scale) and the extracted weight (the weight unloaded from the scale).

The display format used in this operating mode is `Extraction` (see par. 5.2.4 on page 1-42).

The extraction operation can be concluded by pressing `STOP`.

5.5 MPP operation

The 4 previous operating modes may be associated with MPP operation, which is described in detail in par. 6.6 on page 1-71 .

6. OPTIONS

Optional expansion boards (with the exception of the MPP memory expansion board) are installed in the slots provided on the rear of the terminal (see points 11,12 Figure 3.1 on page 1-17).

For the positions and numbering of the outputs (I/O, COM, BCD), refer to the label on the bottom of the terminal.



Figure 6.1 - Outputs identification label on base of terminal
(log0125.jpg)

The numbering of the I/O points, the serial ports and the BCD ports is to be considered along with the position of the boards in the slots (see Figure 3.1 on page 1-17).

D410

Inputs

Slot	N°input	designation
CPU board (slot0)	IN 1	INPUT 01
	IN 2	INPUT 02
Slot1	IN 1	INPUT 11
	IN 2	INPUT 12
	IN 3	INPUT 13
	IN 4	INPUT 14
Slot2	IN 1	INPUT 21
	IN 2	INPUT 22
	IN 3	INPUT 23
	IN 4	INPUT 24

Outputs

Slot	N°output	designation
CPU board (slot0)	OUT 1	OUTPUT 01
	OUT 2	OUTPUT 02
Slot1	OUT 1	OUTPUT 11
	OUT 2	OUTPUT 12
	OUT 3	OUTPUT 13
	OUT 4	OUTPUT 14
Slot2	OUT 1	OUTPUT 21
	OUT 2	OUTPUT 22
	OUT 3	OUTPUT 23
	OUT 4	OUTPUT 24

Serial ports

Slot	N°com	designation
CPU board (slot0)	COM 1	COM 01
	COM 2	COM 02
Slot1	COM 1	COM 11
	COM 2	COM 12
Slot2	COM 1	COM 21
	COM 2	COM 22

BCD

Slot	designation
Slot1	BCD 1
Slot2	BCD 2

6.1 4 I/O board

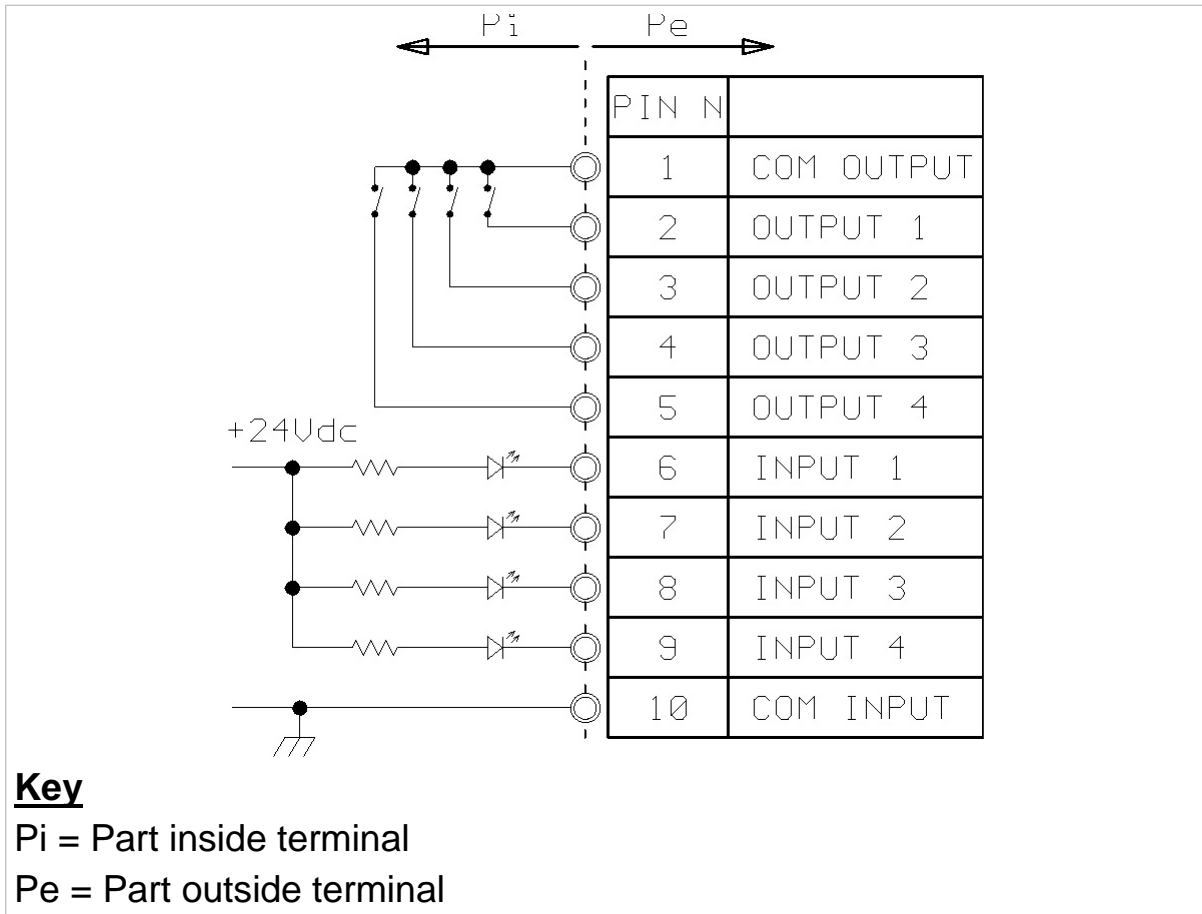

Figure 6.2 - Connection diagram for optional 4 INPUT - 4 OUTPUT board (log0009.gif)

The figure shows the connection terminals of the 4 I/O board.

For specific information on connection refer to par. 3.6 on page 1-27 .

6.2 BCD parallel 5V

The type of board is identified by a label next to the D-type connector. The 25-pin female connector provides BCD signals of the weight as it displayed on the terminal, i.e. number of divisions multiplied by the value of the division.



Operating limits

$V_{out Max} = +5V$

$I_{out Max} = +/- 10 mA$

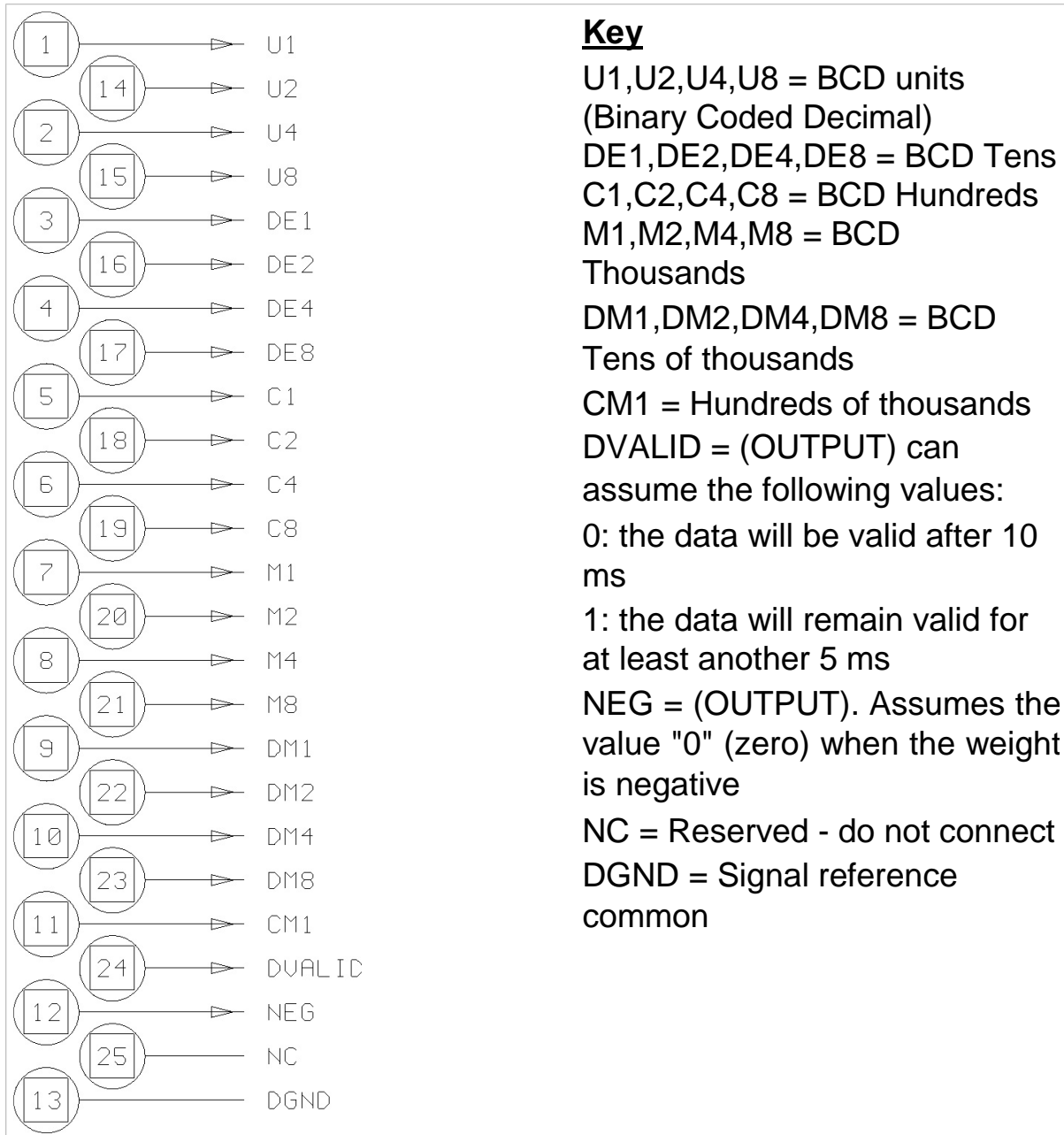

Figure 6.3 - Parallel 5V TTL BCD output connector (log0060.gif)

6.3 Calculator BCD

A label next to the connector identifies the type of board.

The 25-pin female connector provides the following BCD signals representing the weight in divisions without taking into account the value of the division.



The operating limits for this type of output are:

$$V_{\text{out Max}} = +5V$$

$$I_{\text{out Max}} = +/- 10 \text{ mA}$$

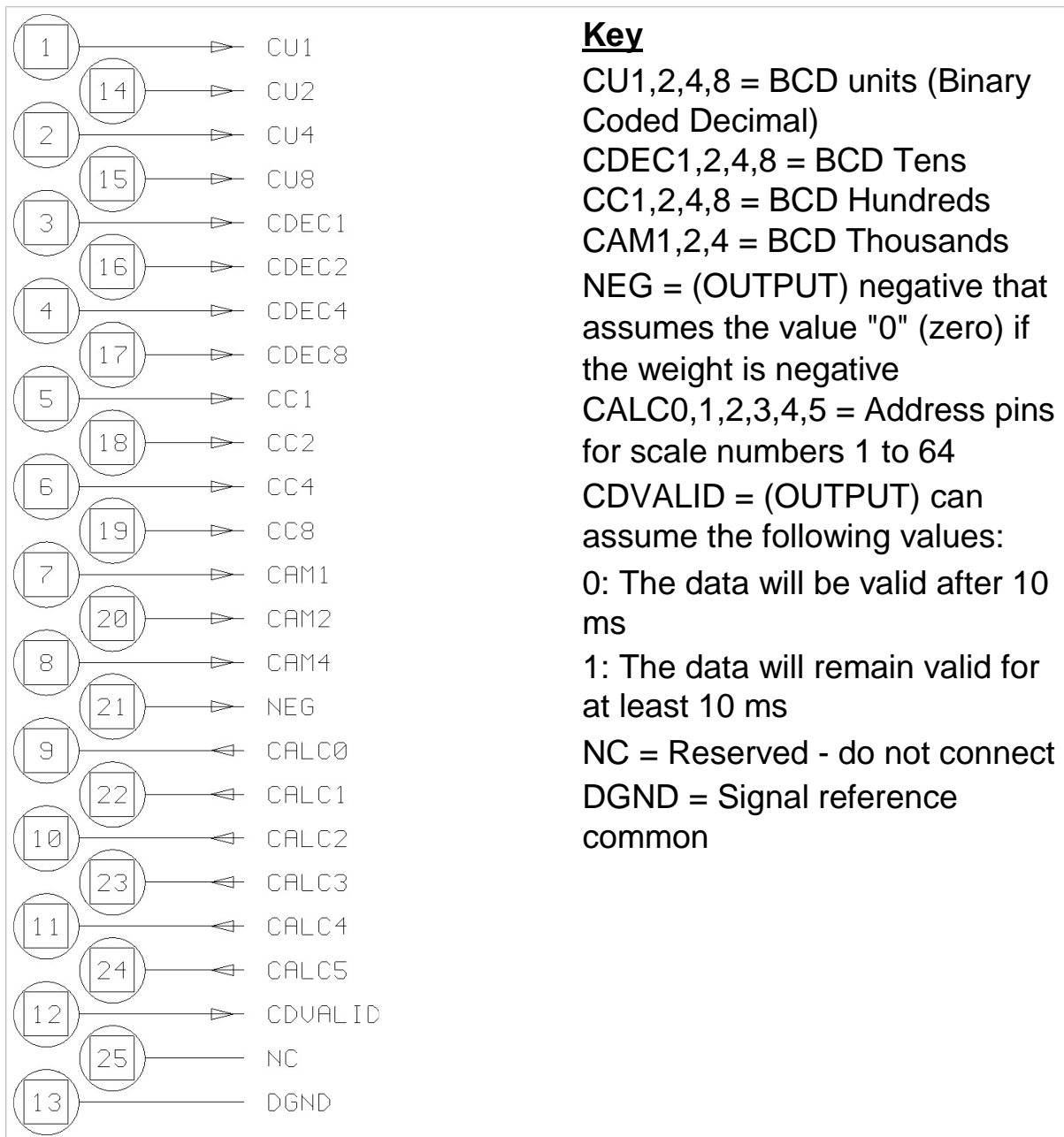

Figure 6.4 - Calculator BCD output connector (log0061.gif)

6.4 Parallel 24V source current BCD (positive common)

A label next to the connector identifies the type of board.

The 25-pin female connector provides the following BCD signals representing the weight value as it is displayed on the terminal, i.e. the number of divisions multiplied by the value of the division.



The operating limits for this output type are as follows:

$$V_{\text{out Max}} = +24\text{V}$$

$$I_{\text{out Max}} = + 10 \text{ mA}$$

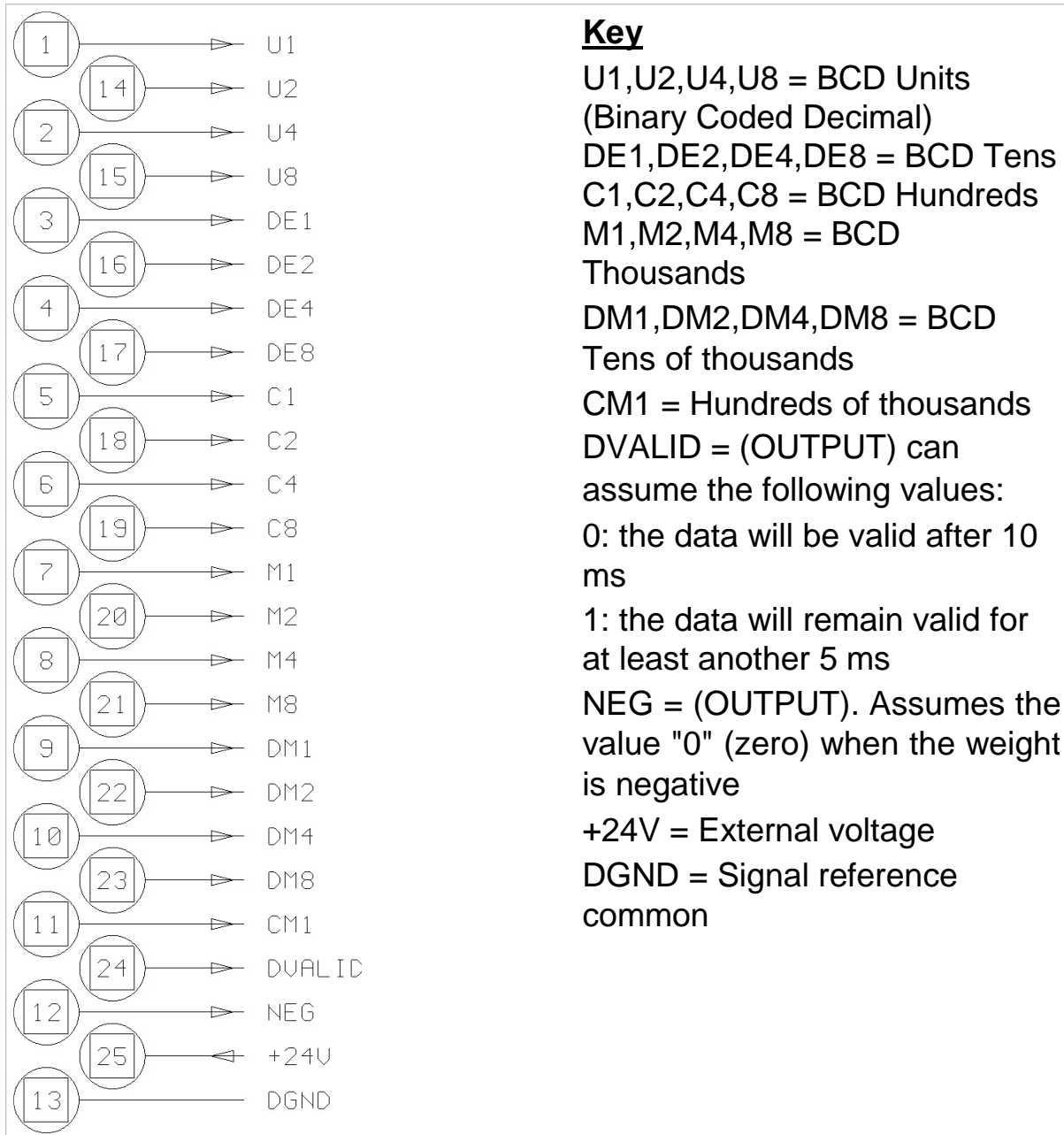

Key

U1,U2,U4,U8 = BCD Units
(Binary Coded Decimal)
DE1,DE2,DE4,DE8 = BCD Tens
C1,C2,C4,C8 = BCD Hundreds
M1,M2,M4,M8 = BCD
Thousands
DM1,DM2,DM4,DM8 = BCD
Tens of thousands
CM1 = Hundreds of thousands
DVALID = (OUTPUT) can
assume the following values:
0: the data will be valid after 10
ms
1: the data will remain valid for
at least another 5 ms
NEG = (OUTPUT). Assumes the
value "0" (zero) when the weight
is negative
+24V = External voltage
DGND = Signal reference
common

Figure 6.5 - Parallel 24V source current BCD output connector (log0062.gif)

The diagram below shows an example of a BCD 24V source current connection between the terminal and an external device.

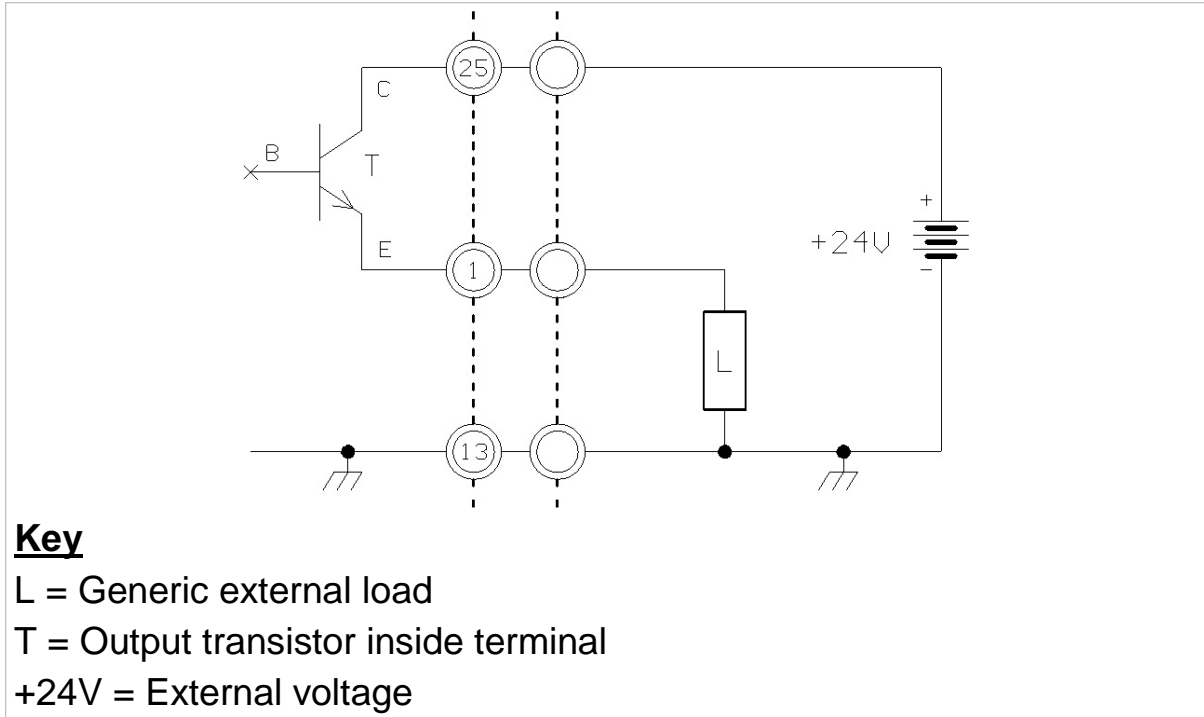

Key

L = Generic external load

T = Output transistor inside terminal

+24V = External voltage

Figure 6.6 - Example of 24V source current connection (log0063.gif)

6.5 Serial port expansion board

The board provides 2 connectors:

- ☞ 9-pin female D-type connector (one RS232/422/485 serial port)(comx1);
 - ☞ 8-pin RJ45 connector (one RS232/422/485 serial port)(comx2).
- The operating limits stipulated by the RS232/422/485 standards are indicated in par. 3.3 on page 1-22 and in par. 3.4 on page 1-23

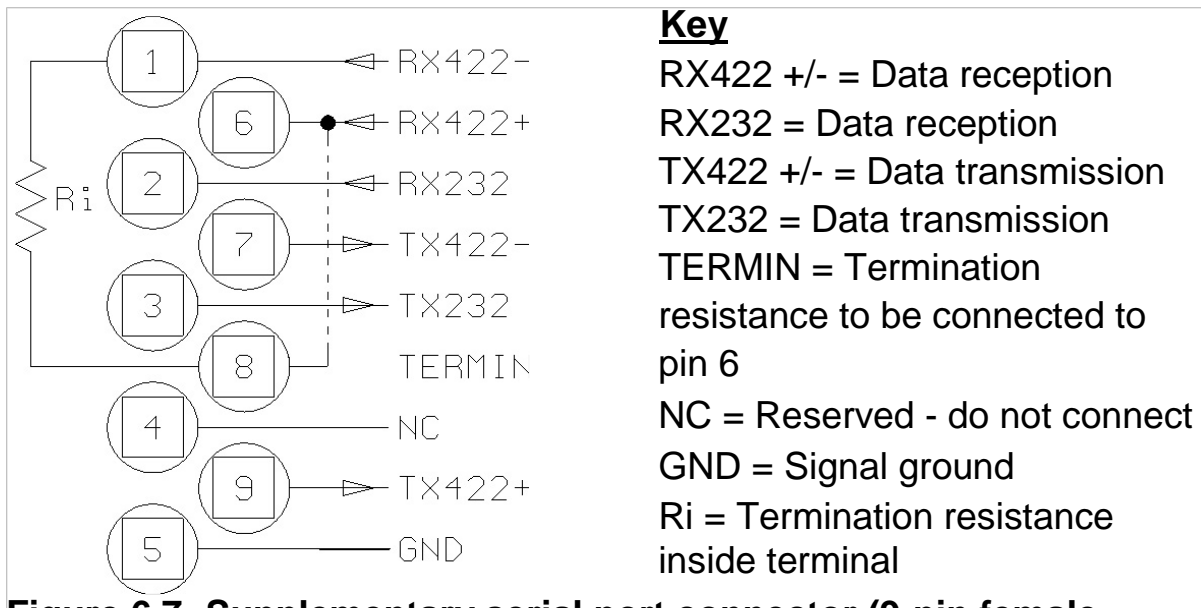
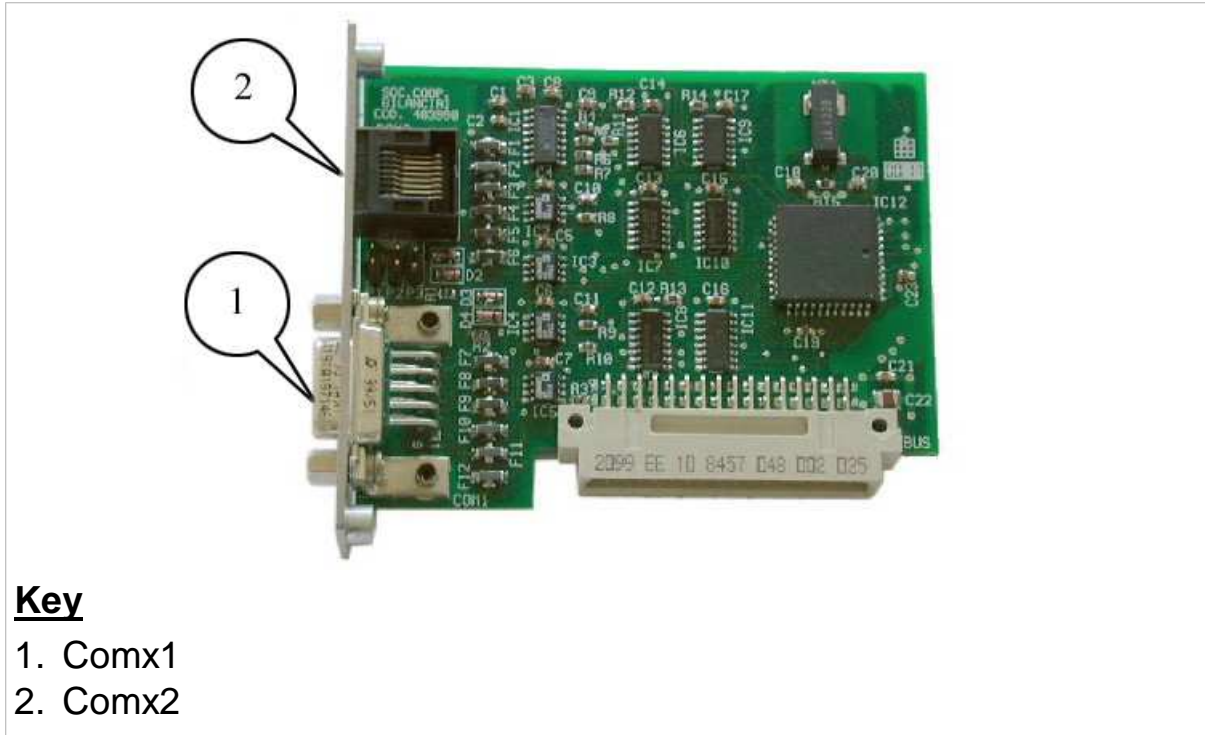

Figure 6.7 -Supplementary serial port connector (9-pin female D-type) (log0064.gif)



Key

- 1. Comx1
- 2. Comx2

Figure 6.8 - Serial port designation (log0129.jpg)

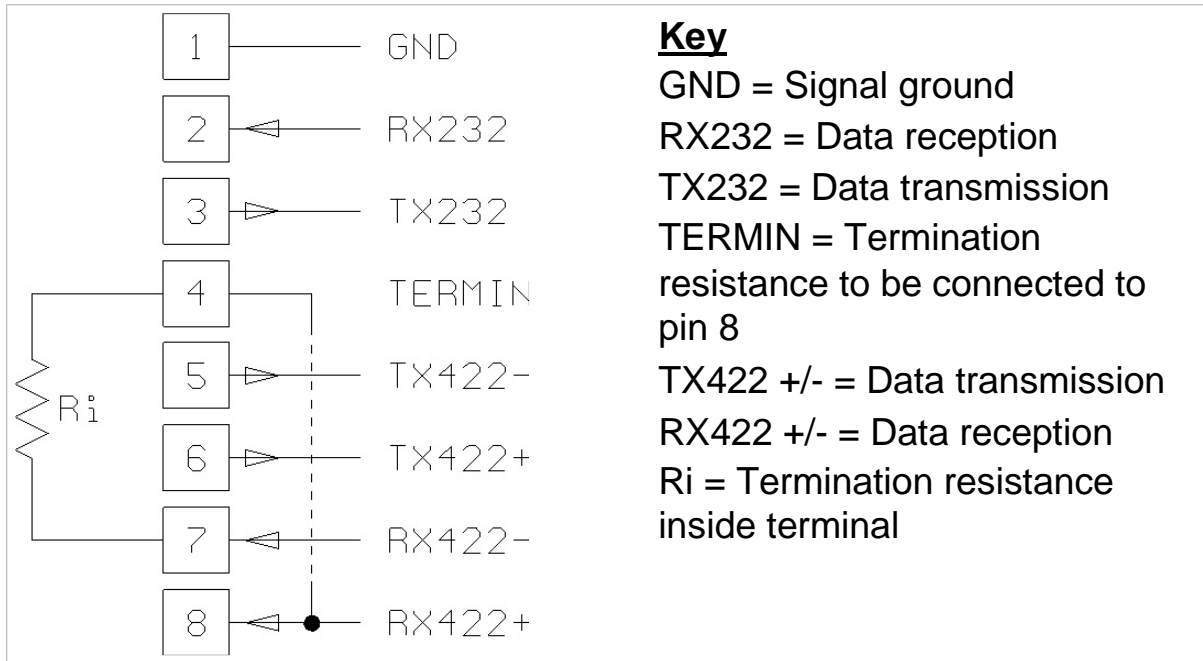

Figure 6.9 - Supplementray serial port connector (RJ45 8-pin)(comx2) (log0065.gif)

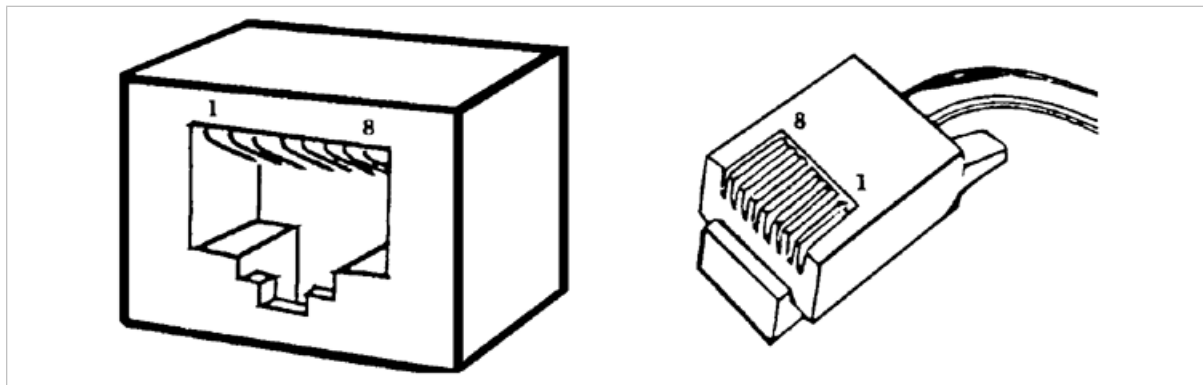

Figure 6.10 - Pin numbering for RJ-45 8-pin connector (log0066.gif)

6.6 MPP memory expansion boards

Terminals equipped with the MPP option (Permanent Weight Memory) can save the weight data of each single weighing operation in a permanent memory or print a paper record (type-approved printer) and transmit the values to a peripheral device, along with an identification code that is automatically assigned by the terminal.

In the case of printing the data (on a type-approved printer), it is not necessary to install the internal optional board. By entering the identification code on the terminal or by checking the paper records, it is possible to verify that the data are correct. The identification number comprises 7 digits, which means that the number will be repeated after 10.000.000 weighing operations.

6.6.1 Memory capacity

The memory capacity of the MPP expansion board is sufficient to store the data for approximately 130,000 weighing operations (weight + tare), which corresponds to around 8 months of continuous use of the terminal, performing 500 weighing operations per day.

If the terminal is used less frequently, this period will be extended.



CAUTION

When maximum memory capacity is reached, the oldest data are deleted and replaced by the most recent.

6.6.2 Operation

The type of MPP operation is defined during installation.

There are two main types of operating mode (for further details see the advanced user manual):

-  in the first type, the user operates from the terminal by pressing  to save and transfer the weight data;
-  in the second type, the user works from the PC keyboard in the way determined by the specific software.

In both operating modes, on completion of the saving operation, the user can display the progressive number associated with the weighing operation (see par. 6.6.4 on page 1-73).

Code MPP will only appear on the display when the memorising operation is enabled with the key.

Both the weighing terminal and the PC may signal errors caused by failure to transfer or save the data correctly. In this event, follow the on-screen instructions.

6.6.3 Disabling MPP

It may sometimes occur that you do not wish to transfer the weight data or save it in the MPP memory.

In this case, to disable MPP, type:

```
...>MENU> MPP operation>De-activated
```

To subsequently re-enable MPP operation:

```
...>MENU>MPP operation>with memory
```

WARNING

Disabling MPP may compromise the operation of equipment connected to the weighing system in that data transfer to such equipment will be inhibited.

You can also access the MPP operation menu by pressing the shortcut key MPP.

6.6.4 Checking memorised weight data

To check the data saved in memory, press the shortcut key `COD MPP`. The terminal displays the net weight and the tare associated with the MPP identification code of the last weighing operation to be performed. By pressing `SETCOD` you can call up previous weighing operation data by entering the relative code number (see par. 5.1.2 on page 1-38).

If the terminal is equipped with a printer, by pressing  you can print the weight data displayed and the relative identification code. The MPP terminal number or serial number may appear in the print heading, depending on the type of response selected during the installation phase.

6.7 12-24Vac-dc input power supplier

The terminal can be powered with a very low safety voltage rating. Ask for installation of the power supplier box with 12-24Vac-dc input. Use the supplied 2-pin connector to connect to the power source. Use a cable with two 1-2mm² section conductors.

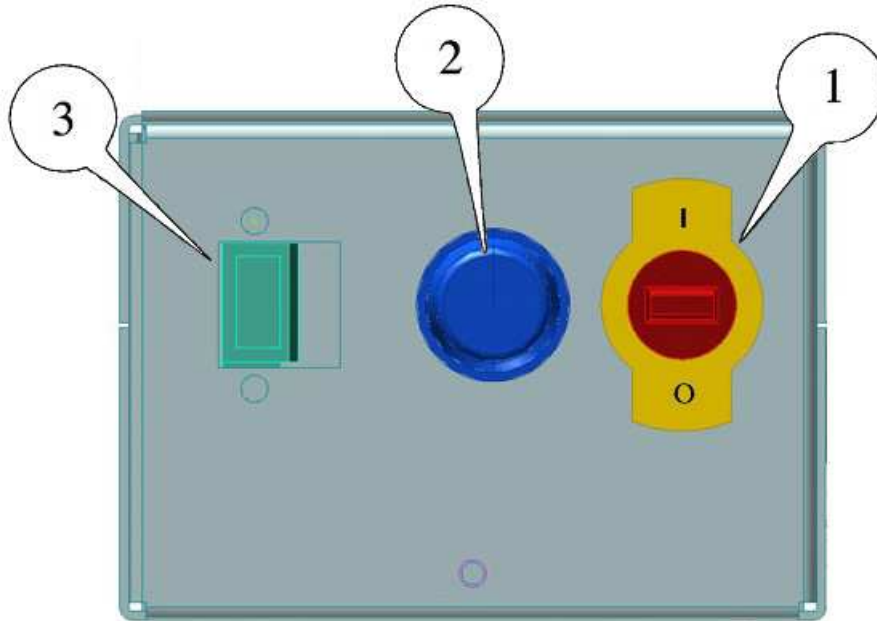

Key

1. ON/OFF switch
2. T4A250V fuses
3. Input connector on panel

Figure 6.11 Connection to the power source with very low safety voltage rating (citi0201.jpg)

 **CAUTION** 

Peak use conditions:

DC (direct current): $V_{min}=11V_{dc}$ $V_{max}=28V_{dc}$

AC (alternate current): $V_{min}=12V_{ac}$ $V_{max}=24V_{ac}$

Maximum power draw=50W

Power cable (not supplied): 2 conductors with 1-2mm² section

6.8 Printers

The printer is usually connected to the terminal by way of the COM1 serial port (Figure 6.12 on page 1-76), although in some exceptional cases it may be connected to the COM2 port .

For special connections, refer to the order documentation.

For information regarding the printer characteristics and maintenance, replacement of paper, ribbon, fuses, etc., refer to the printer instruction manual.

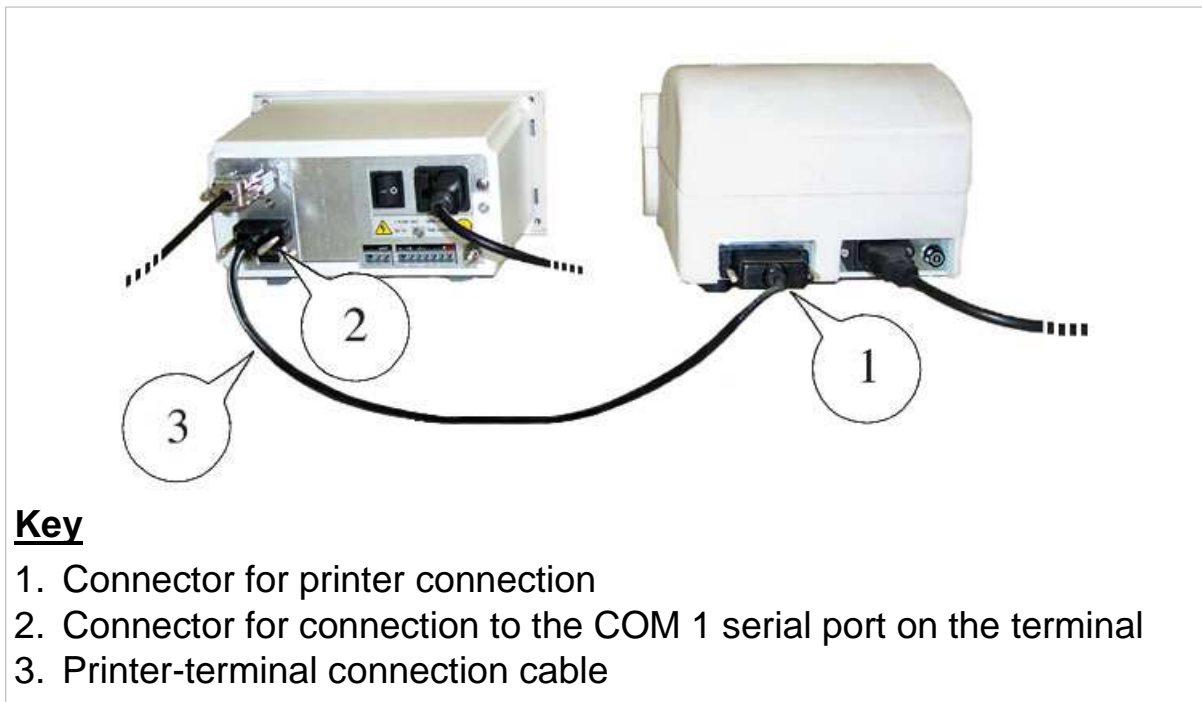

Figure 6.12 Example of printer connection to COM1. (log0128.jpg)

7. MAINTENANCE

7.1 Battery

On switching on the terminal, it performs a check on the condition of the internal lithium battery. If the battery is discharged, the terminal displays the message `CHANGE THE BATTERY` . To change the battery, contact Assistance Service.

7.2 Changing the fuses

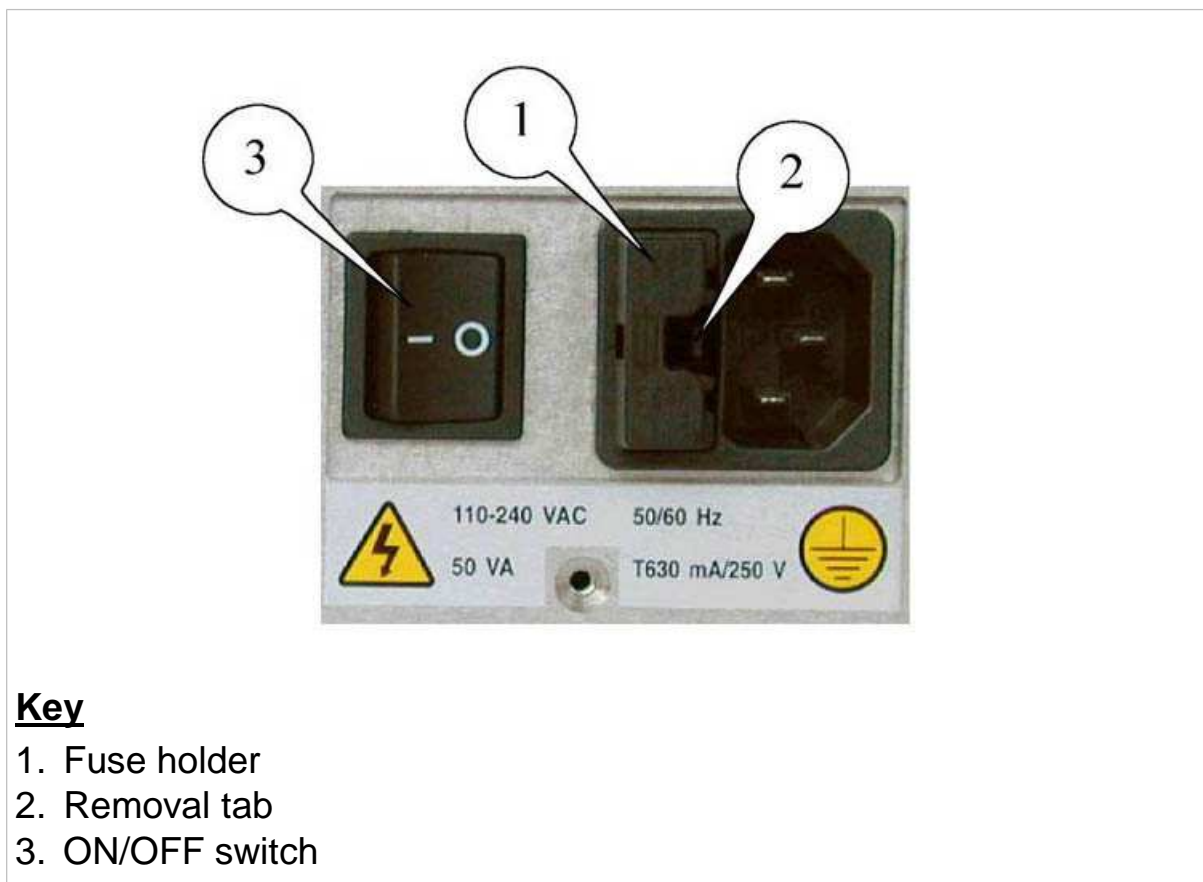

Figure 7.1 - Fuse (log0126.jpg)

⚠ DANGER ⚠



Disconnect the INPUT/OUTPUT cables and the mains lead.

- ☞ Refer to Figure 7.1 on page 1-77
- ☞ Turn the ON/OFF switch to O (off).
- ☞ Press the tab and withdraw the fuse holder.
- ☞ Replace blown fuses with new ones of the same rating (T630mA250V time delay).
- ☞ If the fuse blows again on switching on the terminal, do not make any further attempts to replace it but contact Assistance Service.

8. TROUBLESHOOTING

If the suggested remedy does not solve the problem, contact Assistance Service.

8.1 Malfunctions

Problem	Cause	Remedy
The terminal does not switch on	No power	<p>Check that power arrives at the mains outlet socket.</p> <p>Check that the mains lead is correctly plugged in.</p> <p>Check that the ON/OFF switch is in the position I (ON).</p> <p>Check the fuses.</p>
The display backlighting is on, but no data are displayed	Adjust contrast (set to minimum)	<p>Switch on the terminal while holding pressed  .</p> <p>After a few seconds, the display will show the "CB" logo with the contrast set to maximum, after which the contrast will gradually be reduced.</p> <p>Release  and then press it again to set the contrast at the required level.</p>
- -	Zeroing off-range on powering	Switch off the terminal, unload the scale then power the terminal again.

8.2 Error messages

Problem	Cause	Remedy
9999999 flashing	The scale is overloaded.	Reduce the weight to a value below the maximum scale capacity.
-01-	Converter fault.	Contact Assistance Service.
	Scale connector disconnected or broken.	Switch off the terminal and check that the connector is properly connected. If necessary, disconnect and then re-connect the connector. Switch the terminal back on.
	Digital cells fail to respond	Switch the terminal off and then on again.
-02-	EEPROM error	Switch the terminal off and then on again.
-04-	RAM checksum error	Switch the terminal off and then on again.
-05-	PROGRAM checksum error	Switch the terminal off and then on again.
-06-	Serial number error on digital cell	Switch the terminal off and then on again.

-07-	Digital cell serial number error in system with several load cells	Switch the terminal off and then on again.
-08-	Digital cell serial number error	Switch the terminal off and then on again.
-09-	Digital cell serial number and configuration error	Switch the terminal off and then on again.
-10-	At least one cell not configured	Switch the terminal off and then on again.
-11-	Digital cell powering error	Switch the terminal off and then on again.
-12-	Powering error in one digital cell	Switch the terminal off and then on again.
-13-	Cell with internal temperature off-limits (-40 - 100) °C	Switch the terminal off and then on again.

Change the battery	Internal lithium battery discharged	Contact Assistance Service
Weight not valid	The scale is in negative weight or overload condition and the printer does not print	See conditions for correct printing in par. 5.3 on page 1-52
Printer error	Printer switched off or disconnected	Check printer is connected and switched on
The last line at the bottom of the display of the terminal may show an error message in the following format: <pre>excep n.nn in task xx.x</pre> <p>where n.nn and xx.x are numbers or letters that encode the type of error.</p>	Depends on n.nn and xx.x	Switch the terminal off and then on again. If the error persists, contact the Assistance Service and give them the exact message that appears on the display.

The `Diagnostics` item of the user menu will allow you to establish the cause of errors concerning the digital cells. Consult par. 5.2.7 on page 1-45 .
