



10623 Roselle Street, San Diego, CA 92121 • (858) 550-9559 • Fax (858) 550-7322
contactus@accessio.com • www.accessio.com

**USB MULTI-CHANNEL HIGH-SPEED
ANALOG I/O FAMILY**

**MODEL USB-AIO16-xxx and
USB-AIO12-xxx**

USER MANUAL

File: MUSB-AIO FAMILY.B7i

Notice

The information in this document is provided for reference only. ACCES does not assume any liability arising out of the application or use of the information or products described herein. This document may contain or reference information and products protected by copyrights or patents and does not convey any license under the patent rights of ACCES, nor the rights of others.

IBM PC, PC/XT, and PC/AT are registered trademarks of the International Business Machines Corporation.

Copyright by ACCES I/O Products, Inc. 10623 Roselle Street, San Diego, CA 92121. All rights reserved.

WARNING!!

ALWAYS CONNECT AND DISCONNECT YOUR FIELD CABLING WITH THE COMPUTER POWER OFF. ALWAYS TURN COMPUTER POWER OFF BEFORE INSTALLING A BOARD. CONNECTING AND DISCONNECTING CABLES, OR INSTALLING BOARDS INTO A SYSTEM WITH THE COMPUTER OR FIELD POWER ON MAY CAUSE DAMAGE TO THE I/O BOARD AND WILL VOID ALL WARRANTIES, IMPLIED OR EXPRESSED.

Warranty

Prior to shipment, ACCES equipment is thoroughly inspected and tested to applicable specifications. However, should equipment failure occur, ACCES assures its customers that prompt service and support will be available. All equipment originally manufactured by ACCES which is found to be defective will be repaired or replaced subject to the following considerations.

Terms and Conditions

If a unit is suspected of failure, contact ACCES' Customer Service department. Be prepared to give the unit model number, serial number, and a description of the failure symptom(s). We may suggest some simple tests to confirm the failure. We will assign a Return Material Authorization (RMA) number which must appear on the outer label of the return package. All units/components should be properly packed for handling and returned with freight prepaid to the ACCES designated Service Center, and will be returned to the customer's/user's site freight prepaid and invoiced.

Coverage

First Three Years: Returned unit/part will be repaired and/or replaced at ACCES option with no charge for labor or parts not excluded by warranty. Warranty commences with equipment shipment.

Following Years: Throughout your equipment's lifetime, ACCES stands ready to provide on-site or in-plant service at reasonable rates similar to those of other manufacturers in the industry.

Equipment Not Manufactured by ACCES

Equipment provided but not manufactured by ACCES is warranted and will be repaired according to the terms and conditions of the respective equipment manufacturer's warranty.

General

Under this Warranty, liability of ACCES is limited to replacing, repairing or issuing credit (at ACCES discretion) for any products which are proved to be defective during the warranty period. In no case is ACCES liable for consequential or special damage arriving from use or misuse of our product. The customer is responsible for all charges caused by modifications or additions to ACCES equipment not approved in writing by ACCES or, if in ACCES opinion the equipment has been subjected to abnormal use. "Abnormal use" for purposes of this warranty is defined as any use to which the equipment is exposed other than that use specified or intended as evidenced by purchase or sales representation. Other than the above, no other warranty, expressed or implied, shall apply to any and all such equipment furnished or sold by ACCES.

TABLE OF CONTENTS

Chapter 1: Introduction	6
Features	6
Product Family Overview	7
Functional Description	7
Analog Inputs	8
A/D Conversion Start	9
Oversample	10
Calibration	10
Analog Outputs	10
Digital I/O	11
Counter/Timer	11
Ordering Guide	12
Chapter 2: Installation	17
Software CD Installation	17
Hardware Installation	17
Chapter 3: Hardware Details	18
Option Selection	18
Chapter 4: USB Address Information	20
Chapter 5: Programming	21
Chapter 6: Connector Pin Assignments	22
Chapter 7: Base Model Specifications	24
Chapter 8: Analog Input Multiplexer Model AIMUX-64	26
Features	26
Functional Description	26
Programming Differences from Base Model	26
Exclusive Option for Models that include the AIMUX-64	27
Included with your board	27
Optional Accessories for Models that include the AIMUX-64	27
Adding CJC when using thermocouples with the USB-AIO family	28
Specifications for AIMUX-64	31
Chapter 9: Signal Conditioner Model AIMUX-32	32
Features	32
Functional Description	32
Programming Differences from Base Model	33
Options for Models that include the AIMUX-32	33
Optional Accessories for Models that include the AIMUX-32	33
Front end circuit and connection diagrams	34
Adding CJC when using thermocouples with the AIMUX-32	36
AIMUX-32 Hardware Details	38
Powering the AIMUX-32 boards	40
AIMUX-32 Specification	44
Appendix A: Counter/Timer	45
Appendix B: Calibration	47
System Calibration Utility	49

LIST OF FIGURES

Figure 1-1: Block Diagram	8
Figure 6-1: 68-Pin SCSI Connector Pin Locations	22
Figure 8-1: AIMUX-64 Board with Connectors	27
Figure 8-2: AIMUX-64 Reference Junction Temp Sensor Diagram	28
Figure 8-3: 37-Pin Female Connector Pin Locations	29
Figure 8-4: 25-Pin Female Connector Pin Locations	30
Figure 9-1: C68M-X Multi-SCSI Cable Drawing	33

Figure 9-2: Normal Inputs	34
Figure 9-3: RC Filter	34
Figure 9-4: Attenuation	34
Figure 9-5: Current Input Diagram	35
Figure 9-6: Bridge Completion Diagram	35
Figure 9-7: Thermocouple Input Diagram	36
Figure 9-8: AIMUX-32 Reference Junction Temperature Sensor Diagram	36
Figure 9-9: RTD Input Diagram.....	37
Figure 9-10: AIMUX-32 Option Selection Map	38
Figure 9-11: J5 DB25 Female Connector Pin Locations.....	39
Figure 9-12: DB37 Connector Pin Locations	40
Figure 9-13: USB-AIOxx-128A Mechanical Drawing	43
Figure 9-14: Offset and Gain Error Graphs	47
Figure 9-15: System Calibration Utility Screenshot 1 (setup).....	49
Figure 9-16: System Calibration Utility Screenshot 2 (range select)	49
Figure 9-17: System Calibration Utility Screenshot 3 (offset)	50
Figure 9-18: System Calibration Utility Screenshot 4 (gain)	50
Figure 9-19: System Calibration Utility Screenshot 5 (confirmation)	51
Figure 9-20: System Calibration Utility Screenshot 6 (finish and save)	51

LIST OF TABLES

Table 1-1: 12-Bit OEM and Base Model Number Structure	12
Table 1-2: 12-Bit OEM and Base Model Product Selector	12
Table 1-3: 16-Bit OEM and Base Model Number Structure	13
Table 1-4: 16-Bit OEM and Base Model Product Selector	13
Table 1-5: 12-Bit DAQ-PACK Model Number Structure	14
Table 1-6: 12-Bit DAQ-PACK Model Product Selector	14
Table 1-7: 16-Bit DAQ-PACK Model Number Structure	15
Table 1-8: 16-Bit DAQ-PACK Model Product Selector	15
Table 3-1: Base Model Option Selection Map.....	18
Table 4-1: Product ID to Model Number	20
Table 6-1: Base Model 68-pin SCSI Connector Pin Assignments	22
Table 6-2: Base Model Signal Name, Descriptions and Directions	23
Table 8-1: AIMUX-64 J3 37-Pin Female Connector Pin Assignments	29
Table 8-2: AIMUX-64 J4 37-Pin Female Connector Pin Assignments	30
Table 8-3: AIMUX-64 J2 DB25 Female Connector Pin Assignments	30
Table 8-4: AIMUX-64 Signal Names and Descriptions	31
Table 9-1: AIMUX-32 J5 DB25 Female Connector Pin Assignments	39
Table 9-2: AIMUX-32 J5 Signal Names and Descriptions	39
Table 9-3: AIMUX-32 P2 Power Connector (IDC-8).....	40
Table 9-4: AIMUX-32 P2 Signal Names and Descriptions.....	40
Table 9-5: AIMUX-32 J3 Connector Pin Assignments (DB37F).....	40
Table 9-6: AIMUX-32 J3 Signal Names and Descriptions	41
Table 9-7: AIMUX-32 J4 Connector Pin Assignments (DB37F).....	41
Table 9-8: AIMUX-32 J4 Signal Names and Descriptions	41
Table 9-9: AIMUX-32 J3 DB37 Pin-outs w/CH# per Board Stack Position	42
Table 9-10: AIMUX-32 J4 DB37 Pin-outs w/CH# per Board Stack Position	42

Chapter 1: Introduction

The USB-AIO family of Data Acquisition Modules is an ideal solution for adding portable, easy-to-install high-speed analog and digital I/O capabilities to any computer with a USB port. The unit is a USB 2.0 high-speed device and requires a USB 2.0 port to function.

This manual describes the 120 analog I/O modules within the USB-AIO family. There are 60 OEM models that are shipped with no enclosure, and 60 more enclosed and integrated models. The enclosed models are named DAQ-PACK and DAQ-PACK M Series. OEM versions have model names beginning with USB, while the DAQ-PACK model names start with DPK.

Each model varies in capabilities such as analog to digital (A/D) resolution and sampling speed, calibration hardware, number of channels, signal conditioning capabilities, and analog outputs. Where specific version or model information is referred to with an “xx”, the “xx” are substituted with the total number of channels available on that model. Please refer to Product Selector Tables 1-1 through 1-4 for a complete list of available models.

Features

- High-speed USB 2.0 device
- From 16 single-ended or 8 differential (base models) up to 128 differential analog inputs
- 16-bit resolution versions:
 - Sampling rate
 - “16-xxA”: “Advanced version” 500ksamples/sec (max. aggregate)
 - “16-xxE”: “Economy version” 250ksamples/sec (max. aggregate)
 - Calibration Hardware
 - “16-xxA”: Two on-board references + calibrated real-time output
 - “16-xxE”: Two on-board references
- 12-bit resolution versions:
 - Sampling rate
 - “12-xxA”: “Advanced version” 500ksamples/sec (max. aggregate)
 - “12-xx”: “Standard version” 250ksamples/sec (max. aggregate)
 - “12-xxE”: “Economy version” 100ksamples/sec (max. aggregate)
 - Calibration Hardware
 - “12-xxA”: Two on-board references + calibrated real-time output
 - “12-xx”: Two on-board references
 - “12-xxE”: None
- System calibration program provided to calibrate entire system
- Channel-by-channel ranges of 0-1V, 0-2V, 0-5V, 0-10V, $\pm 1V$, $\pm 2V$, $\pm 5V$, $\pm 10V$ (software selectable)
- Signal conditioning available on -32, -64, -96 and -128 input models for:
 - RC filters on each input
 - Voltage divider on each input
 - 4-20mA and 10-50mA current inputs
 - Thermocouple with break detect (includes Temp sensor for cold junction)
 - RTD measurement
 - Bridge completion
 - Precision 10V excitation at each I/O connector for RTD and Bridge Completion
- A/D Conversion Start sources: Software, Timer, and External Trigger (edge software selectable)
- A/D Modes: Single Channel or Scan
- Noise reduction with Channel Oversampling

- Over-voltage protection of -40V to +55V
- Two 16-bit Digital to Analog (D/A) outputs (optional)
- D/A ranges of 0-5V, 0-10V, $\pm 5V$, $\pm 10V$ (factory installed)
- 16 High-current Digital I/O lines
- 16-bit programmable counter/timer
- PC/104 module size and mounting compatibility
- Small (4" x 4" x 1.25") rugged industrial enclosure available for 16 input version models
- Onboard micro USB connector for embedded applications

Applications

- Equipment monitoring
- Environmental measurements
- Embedded data acquisition
- Education/Laboratory

Product Family Overview

The base models within the product family consist of a USB-based A/D converter board with 16 single-ended (S.E.) or 8 differential (DIFF.) analog inputs, a counter/timer and 16 high-current digital I/O lines. The family is designed using a modular approach with a variety of bit resolutions & sampling speeds.

Optionally, two 16-bit D/A outputs are factory installed for those applications requiring analog outputs.

To increase the channel count of the base models from 16 S.E. or 8 DIFF. to 64 S.E. or 32 DIFF., a multiplexer board (AIMUX-64) is connected to the 68-pin SCSI connector of the A/D board with a ribbon cable.

Alternately, to increase the channel count, introduce signal conditioning capabilities, *and* extra input gain options, from one to four signal conditioning/multiplexer boards (AIMUX-32) can be connected to the A/D board with a multi-SCSI ribbon cable for a maximum of 128 differential analog inputs.

To find the model that is right for your application, refer to product tables 1-1 through 1-8.

Functional Description

This product is an A/D board that converts analog voltages or optionally 4-20/10-50mA to a 16 or 12-bit value (depending on model). This board is capable of sampling speeds up to 500k, 250k, or 100k samples per second (depending on model). Sampling of the A/D can be enabled/disabled using an externally supplied input signal. Analog input channels are enabled as a consecutive set by software. Each channel within the set is independently configured by software to accept one of eight different analog input ranges.

A/D conversion starts are issued one of three ways: Software Start, Timer Start, or External Trigger Start. A/D conversion starts are software configured to be either rising or falling edge. Additionally, A/D conversion starts are software configured to be Single Channel or Scan. Single Channel samples data once from the next consecutive channel within the enabled set. A Scan samples data from all channels within the set at the fastest possible rate. To minimize noise, the board implements a technique called Oversampling. High accuracy is achieved with two on-board reference voltages used in calibrating the board (does not apply to 12-xxE models). Furthermore, a real-time internal calibration system ('A' models only) allows the card to adjust for offset/gain errors at run-time, giving a more accurate reading.

This board also has an option of adding two 16-bit D/A outputs. There are four factory installed output ranges available.

There are 16 digital I/O lines accessible on the I/O connector. The digital I/O lines are grouped into two 8-bit bytes. Both digital I/O bytes are individually software selectable as input or output.

A single, fully programmable, 8254 16-bit counter is provided with a maximum input frequency of 10MHz. The Counter Clock, Counter Gate, & Counter Output can be accessed externally for extended functionality.

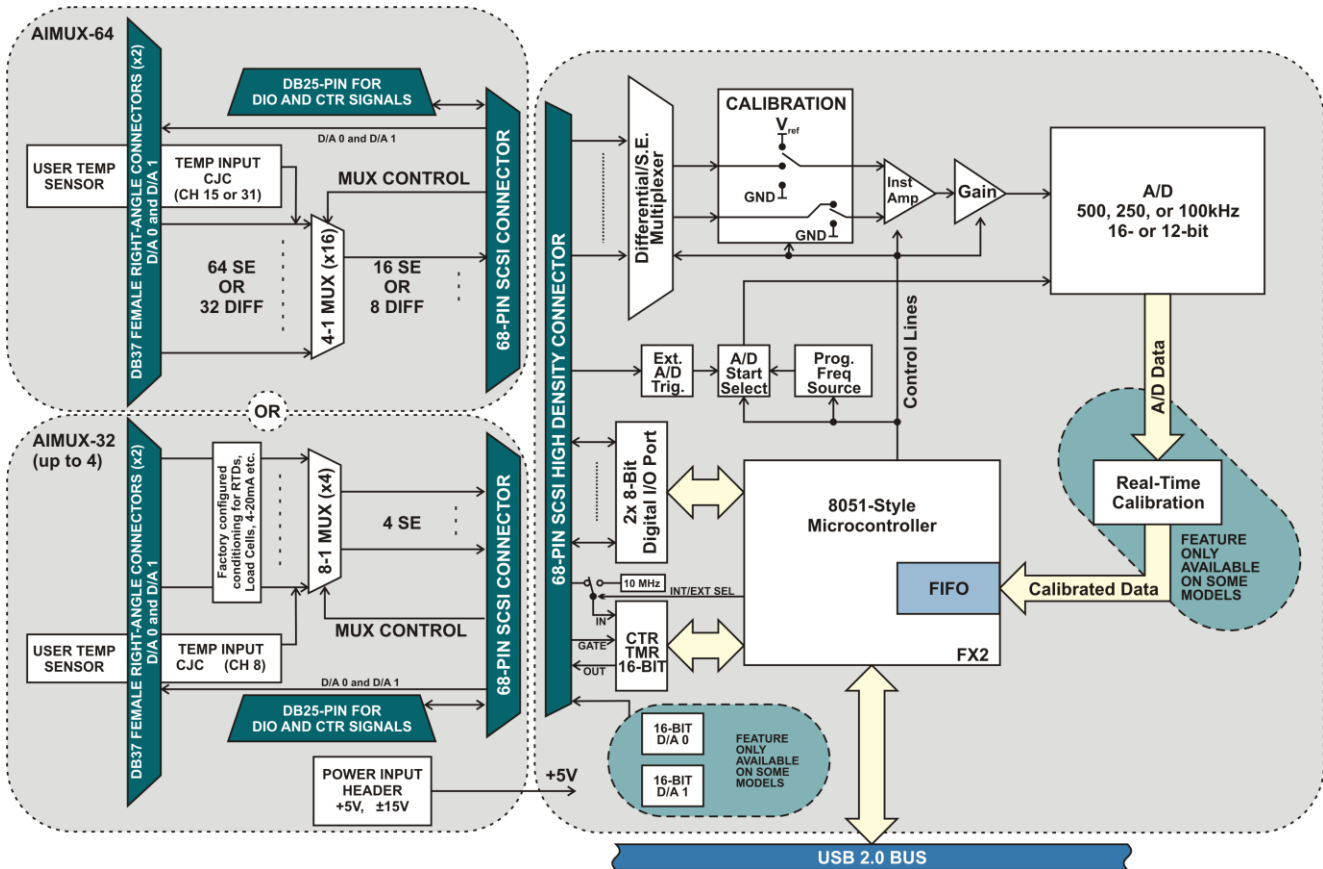

Figure 1-1: Block Diagram

Analog Inputs

Base models have a total of 16 S.E. or 8 DIFF analog inputs. A consecutive set of channels are enabled/disabled by software. This set of channels is constructed by a start and end channel. Sampling begins on the start channel and continues through every successive channel until the end channel is sampled. Once the end channel has been sampled, the process repeats again from the start channel. If only one channel is being sampled, the start and end channels would be the same. Each channel within the set is individually software configured as either S.E. or DIFF. This board allows a mix of both S.E. and DIFF inputs. One must note, however, that a differential signal requires a pair of channels. Thus, when channel 0 is programmed as a DIFF input, both channels 0 and 8 are used and not available as S.E. inputs. Refer to Chapter 6: Connector Pin Assignments, Table 6-1: for S.E. and DIFF pair inputs.

Optionally on base models (16 S.E. or 8 DIFF. inputs), resistors can be factory installed on selected channels to accept 4-20mA or 10-50mA analog inputs. A mix of S.E. *and* DIFF current inputs are possible but they are factory configured in hardware and cannot be changed by software.

8 input ranges, 4 unipolar and 4 bipolar, are selectable by software for each individual channel. This channel-by-channel flexibility allows for up to 8 different input ranges being acquired on a single board. Unipolar ranges are 0-1V, 0-2V, 0-5V, and 0-10V. Bipolar ranges are ± 1 , $\pm 2V$, $\pm 5V$, and $\pm 10V$. Additional gains can be applied to these ranges using the AIMUX-32. Refer to chapter 9.

Each channel input has a slight positive bias to facilitate measurement of signals close to analog ground (no signal information is lost due to negative offset of the ADC; does not apply to 12-xxE models).

Each channel input has an over-voltage protection of -40V to +55V.

A/D Conversion Start

This board offers three software selectable sources for A/D Conversion Start: Software Start, Timer Start, and External Start Trigger. Software Start generates an A/D Conversion Start every time the software command is issued. The maximum frequency for a Software Start is roughly 4kHz. Timer Start uses the on-board timer to generate an A/D Conversion Start. Frequencies ranging from $2.33 * 10^{-3}Hz$ to 500kHz are possible with Timer Start. External Start Trigger uses the External Trigger pin on the connector to generate an A/D Conversion Start. Frequencies up to 500kHz are allowed for External Start Trigger. **Note that the frequency of A/D conversion starts CANNOT exceed the speed of the A/D conversions.*

A/D Conversion Start is also software configured as rising or falling edge. Furthermore, it can be disabled by driving the A/D Conversion Start Enable pin on the connector low. By default, this signal is pulled high and A/D Conversion Start is enabled. If A/D Conversion Start Enable goes low during a conversion, the current channel (plus any oversampling; refer to the Oversample section) will complete all its conversions before A/D Conversion Start is disabled. Once A/D Conversion Start Enable returns high, conversions will begin on the next successive channel within the enabled set upon the following A/D Conversion Start.

An A/D Conversion Start can be one of two software selectable types for this board: Single Channel or Scan. A/D conversion starts that are Single Channel sample one channel within the enabled set per A/D Conversion Start. This allows for total control over the time skew between channels.

Scan, on the other hand, will sample all the channels within the enabled set per A/D Conversion Start. Channels are sampled at 500kHz, 250kHz, or 100kHz (depending on model) to minimize the time skew between channels. Furthermore, 'A' Models have the software selectable Scan option of sampling channels at 500kHz or 400kHz. The slower sampling rate mitigates crosstalk between analog input channels.

Oversample

Oversampling is a technique which continuously samples a channel multiple times at the board's fastest speed. Quickly taking several samples from the same channel allows the signal to be averaged. Averaging a signal can greatly reduce the noise injected by both the signal and the board/system.

The oversample range is from 0 to 255 (software selectable) and applies to every channel within the enabled set. A channel is always sampled once, plus the number of oversamples that was configured. Therefore an oversample of 0 will sample a channel once (initial sample plus 0 oversamples), oversample of 1 will sample a channel twice (initial sample plus 1 oversample), up to an oversample of 255 which will sample a channel 256 times (initial sample plus 255 oversamples).

Each channel's oversamples are taken before sampling begins on the next consecutive channel within the enabled set.

Calibration

All ADC's suffer from offset and gain errors. To account for this, the board contains calibration hardware and software to adjust for the offset/gain errors. This is particularly helpful as aging occurs and/or operating temperature changes.

There are two on-board hardware components used for calibration. The first hardware component uses two on-board known reference voltages that are accessible by software. The first reference voltage measures analog ground while the second reference voltage measures Vref, which is slightly below 10V. The results of sampling analog ground provides the information for correcting any offset errors present. Sampling Vref provides the information for correcting any gain errors present by comparing against Vref's known value which was accurately measured at the factory and stored on-board. Note: "12-xxE" boards do not contain the on-board reference voltages.

The second hardware component, contained by 'A' models only, provides real-time calibrated data. This component uses the calibration file created from the two on-board reference voltages or a custom calibration file generated by the user (refer to the Software Reference manual for the file format). The calibration file is loaded onto the board and used by the real-time calibration hardware. The result is real-time calibrated data. Autocalibration is a function in software that, when called, will automatically sample the two on-board references, create the calibration file, and store the calibrated information onto the board. Autocalibration can be performed in milliseconds and is recommended to be performed periodically. For optimum calibrated data, the software function should be repeated anytime the temperature or environment changes.

Appendix B describes calibration in greater detail. It gives thorough explanations and provides useful diagrams demonstrating the concepts of offset and gain errors as well as other common sources of error. It also provides equations used to calibrate out errors and how those equations were derived.

Analog Outputs

Optional analog outputs provide two singled-ended, 16-bit D/A outputs capable of a 4kHz conversion rate per channel. Both channels ship standard with a 0-10V range. Other ranges available as factory options are: 0-5V, $\pm 5V$, and $\pm 10V$. See Model Options for details on specifying the factory ranges. Output current is $\pm 25mA$ per channel.

Digital I/O

There are 16 digital I/O lines (DIO0 to DIO15) available on the I/O connector. Both the low byte (DIO0-DIO7) and high byte (DIO8-DIO15) can be individually software configured as inputs or outputs. Each DIO line is buffered and capable of sourcing 32mA or sinking 64mA. Be sure to consult the Power section for total power limitations before operation. By default the DIO lines are pulled up with a 10K Ω resistor to 5V. DIO lines can also be factory configured as pulled down.

Counter/Timer

The highly versatile 8254 contains three independent counter/timers. Counter 0 is available for general purpose use as described below. Counters 1 and 2 are dedicated for use in timing A/D conversion starts. See **Appendix A** for detailed 8254 operational mode descriptions.

Counter 0 is a fully programmable, 8254 16-bit counter is provided with the Counter Gate, Counter Clock, and Counter Output signals brought out to the connector. All three signals are buffered and capable of sourcing 32mA or sinking 64mA. Be sure to consult the Power section for total power limitations before operation. The Counter Gate, Counter Clock, and Counter Output are pulled up with a 10k Ω resistor to 5V.

The Counter Clock input is software selectable between an internal 10MHz clock and the external Counter Clock. The maximum allowed frequency for the clock is 10MHz.

Ordering Guide

Use the following tables to select the family model that is right for your application.

USB-XXX12-YYYZ	12-Bit Input OEM (no enclosures) and Base Models (board w/enclosure included as standard, option for OEM version)
XXX	AI = Analog Inputs AIO = Analog Inputs/Outputs
YYY	16 = 16S.E./8DIFF Channels (No MUX) 64M = 64S.E./32DIFF Channels (Includes AIMUX-64) 32, 64, 96, 128 = 32, 64, 96, 128 DIFF Channels (1, 2, 3, 4 AIMUX-32 Respectively)
Z	A = Advanced Model; 500k, CAL ibration REF erence, Real-Time Cal. HW (constants stored on-board, update A/D values in real-time) No Letter = Standard Model; 250k, CAL ibration REF erence E = Economy Model; 100k

Table 1-1: 12-Bit OEM and Base Model Number Structure

	12-Bit Products	# of Inputs	A/D Rate (kHz)	CAL		D/A	Board(s)	I/O Connector(s)	Power Required
				REF	Real-Time				
1	USB-AI12-16A	16SE / 8 DIFF	500	YES	YES	0	A/D	68-Pin Male SCSI	5V via USB or Ext Supply
2	USB-AI12-16	16SE / 8 DIFF	250	YES	NO	0	A/D	68-Pin Male SCSI	5V via USB or Ext Supply
3	USB-AI12-16E	16SE / 8 DIFF	100	NO	NO	0	A/D	68-Pin Male SCSI	5V via USB or Ext Supply
4	USB-AI12-32A	32 DIFF	500	YES	YES	0	A/D, AIMUX-32	DB37 Female x 2	±15V, +5V via AIMUX-32
5	USB-AI12-32	32 DIFF	250	YES	NO	0	A/D, AIMUX-32	DB37 Female x 2	±15V, +5V via AIMUX-32
6	USB-AI12-32E	32 DIFF	100	NO	NO	0	A/D, AIMUX-32	DB37 Female x 2	±15V, +5V via AIMUX-32
7	USB-AI12-64A	64 DIFF	500	YES	YES	0	A/D, AIMUX-32(x2)	DB37 Female x 4	±15V, +5V via AIMUX-32
8	USB-AI12-64	64 DIFF	250	YES	NO	0	A/D, AIMUX-32(x2)	DB37 Female x 4	±15V, +5V via AIMUX-32
9	USB-AI12-64E	64 DIFF	100	NO	NO	0	A/D, AIMUX-32(x2)	DB37 Female x 4	±15V, +5V via AIMUX-32
10	USB-AI12-64MA	64SE / 32 DIFF	500	YES	YES	0	A/D, AIMUX-64	DB37 Female x 2	5V via USB or Ext Supply
11	USB-AI12-64M	64SE / 32 DIFF	250	YES	NO	0	A/D, AIMUX-64	DB37 Female x 2	5V via USB or Ext Supply
12	USB-AI12-64ME	64SE / 32 DIFF	100	NO	NO	0	A/D, AIMUX-64	DB37 Female x 2	5V via USB or Ext Supply
13	USB-AI12-96A	96 DIFF	500	YES	YES	0	A/D, AIMUX-32(x3)	DB37 Female x 6	±15V, +5V via AIMUX-32
14	USB-AI12-96	96 DIFF	250	YES	NO	0	A/D, AIMUX-32(x3)	DB37 Female x 6	±15V, +5V via AIMUX-32
15	USB-AI12-96E	96 DIFF	100	NO	NO	0	A/D, AIMUX-32(x3)	DB37 Female x 6	±15V, +5V via AIMUX-32
16	USB-AI12-128A	128 DIFF	500	YES	YES	0	A/D, AIMUX-32(x4)	DB37 Female x 8	±15V, +5V via AIMUX-32
17	USB-AI12-128	128 DIFF	250	YES	NO	0	A/D, AIMUX-32(x4)	DB37 Female x 8	±15V, +5V via AIMUX-32
18	USB-AI12-128E	128 DIFF	100	NO	NO	0	A/D, AIMUX-32(x4)	DB37 Female x 8	±15V, +5V via AIMUX-32
19	USB-AIO12-16A	16SE / 8 DIFF	500	YES	YES	2	A/D	68-Pin Male SCSI	5V via USB or Ext Supply
20	USB-AIO12-16	16SE / 8 DIFF	250	YES	NO	2	A/D	68-Pin Male SCSI	5V via USB or Ext Supply
21	USB-AIO12-16E	16SE / 8 DIFF	100	NO	NO	2	A/D	68-Pin Male SCSI	5V via USB or Ext Supply
22	USB-AIO12-32A	32 DIFF	500	YES	YES	2	A/D, AIMUX-32	DB37 Female x 2	±15V, +5V via AIMUX-32
23	USB-AIO12-32	32 DIFF	250	YES	NO	2	A/D, AIMUX-32	DB37 Female x 2	±15V, +5V via AIMUX-32
24	USB-AIO12-32E	32 DIFF	100	NO	NO	2	A/D, AIMUX-32	DB37 Female x 2	±15V, +5V via AIMUX-32
25	USB-AIO12-64A	64 DIFF	500	YES	YES	2	A/D, AIMUX-32(x2)	DB37 Female x 4	±15V, +5V via AIMUX-32
26	USB-AIO12-64	64 DIFF	250	YES	NO	2	A/D, AIMUX-32(x2)	DB37 Female x 4	±15V, +5V via AIMUX-32
27	USB-AIO12-64E	64 DIFF	100	NO	NO	2	A/D, AIMUX-32(x2)	DB37 Female x 4	±15V, +5V via AIMUX-32
28	USB-AIO12-64MA	64SE / 32 DIFF	500	YES	YES	2	A/D, AIMUX-64	DB37 Female x 2	5V via USB or Ext Supply
29	USB-AIO12-64M	64SE / 32 DIFF	250	YES	NO	2	A/D, AIMUX-64	DB37 Female x 2	5V via USB or Ext Supply
30	USB-AIO12-64ME	64SE / 32 DIFF	100	NO	NO	2	A/D, AIMUX-64	DB37 Female x 2	5V via USB or Ext Supply
31	USB-AIO12-96A	96 DIFF	500	YES	YES	2	A/D, AIMUX-32(x3)	DB37 Female x 6	±15V, +5V via AIMUX-32
32	USB-AIO12-96	96 DIFF	250	YES	NO	2	A/D, AIMUX-32(x3)	DB37 Female x 6	±15V, +5V via AIMUX-32
33	USB-AIO12-96E	96 DIFF	100	NO	NO	2	A/D, AIMUX-32(x3)	DB37 Female x 6	±15V, +5V via AIMUX-32
34	USB-AIO12-128A	128 DIFF	500	YES	YES	2	A/D, AIMUX-32(x4)	DB37 Female x 8	±15V, +5V via AIMUX-32
35	USB-AIO12-128	128 DIFF	250	YES	NO	2	A/D, AIMUX-32(x4)	DB37 Female x 8	±15V, +5V via AIMUX-32
36	USB-AIO12-128E	128 DIFF	100	NO	NO	2	A/D, AIMUX-32(x4)	DB37 Female x 8	±15V, +5V via AIMUX-32

Table 1-2: 12-Bit OEM and Base Model Product Selector

USB-XXX16-YYYY	16-Bit Input OEM (no enclosures) and Base Models (board w/enclosure included as standard, option for OEM version)
XXX	AI = Analog Inputs AIO = Analog Inputs/Outputs
YYY	16 = 16S.E./8DIFF Channels (No MUX) 64M = 64S.E./32DIFF Channels (Includes AIMUX-64) 32, 64, 96, 128 = 32, 64, 96, 128 DIFF Channels (1, 2, 3, 4 AIMUX-32 Respectively)
Z	A = Advanced Model; 500k, CAL ibration REF erence, Real-Time Cal. HW (constants stored on-board, update A/D values in real-time) E = Economy Model; 250k, CAL ibration REF erence

Table 1-3: 16-Bit OEM and Base Model Number Structure

	16-Bit Products	# of Inputs	A/D Rate (kHz)	CAL		D/A	Board(s)	I/O Connector(s)	Power Required
				REF	Real-Time				
37	USB-AI16-16A	16SE / 8 DIFF	500	YES	YES	0	A/D	68-Pin Male SCSI	5V via USB or Ext Supply
38	USB-AI16-16E	16SE / 8 DIFF	250	YES	NO	0	A/D	68-Pin Male SCSI	5V via USB or Ext Supply
39	USB-AI16-32A	32 DIFF	500	YES	YES	0	A/D, AIMUX-32	DB37 Female x 2	±15V, +5V via AIMUX-32
40	USB-AI16-32E	32 DIFF	250	YES	NO	0	A/D, AIMUX-32	DB37 Female x 2	±15V, +5V via AIMUX-32
41	USB-AI16-64A	64 DIFF	500	YES	YES	0	A/D, AIMUX-32(x2)	DB37 Female x 4	±15V, +5V via AIMUX-32
42	USB-AI16-64E	64 DIFF	250	YES	NO	0	A/D, AIMUX-32(x2)	DB37 Female x 4	±15V, +5V via AIMUX-32
43	USB-AI16-64MA	64SE / 32 DIFF	500	YES	YES	0	A/D, AIMUX-64	DB37 Female x 2	5V via USB or Ext Supply
44	USB-AI16-64ME	64SE / 32 DIFF	250	YES	NO	0	A/D, AIMUX-64	DB37 Female x 2	5V via USB or Ext Supply
45	USB-AI16-96A	96 DIFF	500	YES	YES	0	A/D, AIMUX-32(x3)	DB37 Female x 6	±15V, +5V via AIMUX-32
46	USB-AI16-96E	96 DIFF	250	YES	NO	0	A/D, AIMUX-32(x3)	DB37 Female x 6	±15V, +5V via AIMUX-32
47	USB-AI16-128A	128 DIFF	500	YES	YES	0	A/D, AIMUX-32(x4)	DB37 Female x 8	±15V, +5V via AIMUX-32
48	USB-AI16-128E	128 DIFF	250	YES	NO	0	A/D, AIMUX-32(x4)	DB37 Female x 8	±15V, +5V via AIMUX-32
49	USB-AIO16-16A	16SE / 8 DIFF	500	YES	YES	2	A/D	68-Pin Male SCSI	5V via USB or Ext Supply
50	USB-AIO16-16E	16SE / 8 DIFF	250	YES	NO	2	A/D	68-Pin Male SCSI	5V via USB or Ext Supply
51	USB-AIO16-32A	32 DIFF	500	YES	YES	2	A/D, AIMUX-32	DB37 Female x 2	±15V, +5V via AIMUX-32
52	USB-AIO16-32E	32 DIFF	250	YES	NO	2	A/D, AIMUX-32	DB37 Female x 2	±15V, +5V via AIMUX-32
53	USB-AIO16-64A	64 DIFF	500	YES	YES	2	A/D, AIMUX-32(x2)	DB37 Female x 4	±15V, +5V via AIMUX-32
54	USB-AIO16-64E	64 DIFF	250	YES	NO	2	A/D, AIMUX-32(x2)	DB37 Female x 4	±15V, +5V via AIMUX-32
55	USB-AIO16-64MA	64SE / 32 DIFF	500	YES	YES	2	A/D, AIMUX-64	DB37 Female x 2	5V via USB or Ext Supply
56	USB-AIO16-64ME	64SE / 32 DIFF	250	YES	NO	2	A/D, AIMUX-64	DB37 Female x 2	5V via USB or Ext Supply
57	USB-AIO16-96A	96 DIFF	500	YES	YES	2	A/D, AIMUX-32(x3)	DB37 Female x 6	±15V, +5V via AIMUX-32
58	USB-AIO16-96E	96 DIFF	250	YES	NO	2	A/D, AIMUX-32(x3)	DB37 Female x 6	±15V, +5V via AIMUX-32
59	USB-AIO16-128A	128 DIFF	500	YES	YES	2	A/D, AIMUX-32(x4)	DB37 Female x 8	±15V, +5V via AIMUX-32
60	USB-AIO16-128E	128 DIFF	250	YES	NO	2	A/D, AIMUX-32(x4)	DB37 Female x 8	±15V, +5V via AIMUX-32

Table 1-4: 16-Bit OEM and Base Model Product Selector

DPK-XXX12- YYYYZ	12-Bit Input DAQ-PACK Models (Enclosed and Integrated USB Data Acquisition Modules)
XXX	AI = Analog Inputs AIO = Analog Inputs/Outputs
YYY	16 = 16S.E./8DIFF Channels 64M = 64S.E./32DIFF Channels (DAQ-PACK M Series) 32, 64, 96, 128 = 32, 64, 96, 128 DIFF Channels
Z	A = Advanced Model; 500k, CAL ibration REF erence, Real-Time Cal. HW (constants stored on-board, update A/D values in real-time) No Letter = Standard Model; 250k, CAL ibration REF erence E = Economy Model; 100k

Table 1-5: 12-Bit DAQ-PACK Model Number Structure

	12-Bit DAQ-PACK Models	# of Inputs	A/D Rate (kHz)	CAL		D/A	I/O Connector(s)	Power Required
				REF	Real-Time			
61	DPK-AI12-16A	16SE / 8 DIFF	500	YES	YES	0	68-Pin Male SCSI	5V via USB or Ext Supply
62	DPK-AI12-16	16SE / 8 DIFF	250	YES	NO	0	68-Pin Male SCSI	5V via USB or Ext Supply
63	DPK-AI12-16E	16SE / 8 DIFF	100	NO	NO	0	68-Pin Male SCSI	5V via USB or Ext Supply
64	DPK-AI12-32A	32 DIFF	500	YES	YES	0	DB37 Female x 2	±15V, +5V
65	DPK-AI12-32	32 DIFF	250	YES	NO	0	DB37 Female x 2	±15V, +5V
66	DPK-AI12-32E	32 DIFF	100	NO	NO	0	DB37 Female x 2	±15V, +5V
67	DPK-AI12-64A	64 DIFF	500	YES	YES	0	DB37 Female x 4	±15V, +5V
68	DPK-AI12-64	64 DIFF	250	YES	NO	0	DB37 Female x 4	±15V, +5V
69	DPK-AI12-64E	64 DIFF	100	NO	NO	0	DB37 Female x 4	±15V, +5V
70	DPK-AI12-64MA	64SE / 32 DIFF	500	YES	YES	0	DB37 Female x 2	5V via USB or Ext Supply
71	DPK-AI12-64M	64SE / 32 DIFF	250	YES	NO	0	DB37 Female x 2	5V via USB or Ext Supply
72	DPK-AI12-64ME	64SE / 32 DIFF	100	NO	NO	0	DB37 Female x 2	5V via USB or Ext Supply
73	DPK-AI12-96A	96 DIFF	500	YES	YES	0	DB37 Female x 6	±15V, +5V
74	DPK-AI12-96	96 DIFF	250	YES	NO	0	DB37 Female x 6	±15V, +5V
75	DPK-AI12-96E	96 DIFF	100	NO	NO	0	DB37 Female x 6	±15V, +5V
76	DPK-AI12-128A	128 DIFF	500	YES	YES	0	DB37 Female x 8	±15V, +5V
77	DPK-AI12-128	128 DIFF	250	YES	NO	0	DB37 Female x 8	±15V, +5V
78	DPK-AI12-128E	128 DIFF	100	NO	NO	0	DB37 Female x 8	±15V, +5V
79	DPK-AIO12-16A	16SE / 8 DIFF	500	YES	YES	2	68-Pin Male SCSI	5V via USB or Ext Supply
80	DPK-AIO12-16	16SE / 8 DIFF	250	YES	NO	2	68-Pin Male SCSI	5V via USB or Ext Supply
81	DPK-AIO12-16E	16SE / 8 DIFF	100	NO	NO	2	68-Pin Male SCSI	5V via USB or Ext Supply
82	DPK-AIO12-32A	32 DIFF	500	YES	YES	2	DB37 Female x 2	±15V, +5V
83	DPK-AIO12-32	32 DIFF	250	YES	NO	2	DB37 Female x 2	±15V, +5V
84	DPK-AIO12-32E	32 DIFF	100	NO	NO	2	DB37 Female x 2	±15V, +5V
85	DPK-AIO12-64A	64 DIFF	500	YES	YES	2	DB37 Female x 4	±15V, +5V
86	DPK-AIO12-64	64 DIFF	250	YES	NO	2	DB37 Female x 4	±15V, +5V
87	DPK-AIO12-64E	64 DIFF	100	NO	NO	2	DB37 Female x 4	±15V, +5V
88	DPK-AIO12-64MA	64SE / 32 DIFF	500	YES	YES	2	DB37 Female x 2	5V via USB or Ext Supply
89	DPK-AIO12-64M	64SE / 32 DIFF	250	YES	NO	2	DB37 Female x 2	5V via USB or Ext Supply
90	DPK-AIO12-64ME	64SE / 32 DIFF	100	NO	NO	2	DB37 Female x 2	5V via USB or Ext Supply
91	DPK-AIO12-96A	96 DIFF	500	YES	YES	2	DB37 Female x 6	±15V, +5V
92	DPK-AIO12-96	96 DIFF	250	YES	NO	2	DB37 Female x 6	±15V, +5V
93	DPK-AIO12-96E	96 DIFF	100	NO	NO	2	DB37 Female x 6	±15V, +5V
94	DPK-AIO12-128A	128 DIFF	500	YES	YES	2	DB37 Female x 8	±15V, +5V
95	DPK-AIO12-128	128 DIFF	250	YES	NO	2	DB37 Female x 8	±15V, +5V
96	DPK-AIO12-128E	128 DIFF	100	NO	NO	2	DB37 Female x 8	±15V, +5V

Table 1-6: 12-Bit DAQ-PACK Model Product Selector

DPK-XXX16-YYYZ	16-Bit Input DAQ-PACK Models (Enclosed and Integrated USB Data Acquisition Modules)
XXX	AI = Analog Inputs AIO = Analog Inputs/Outputs
YYY	16 = 16S.E./8DIFF Channels 64M = 64S.E./32DIFF Channels 32, 64, 96, 128 = 32, 64, 96, 128 DIFF Channels
Z	A = Advanced Model; 500k, CAL ibration REF erence, Real-Time Cal. HW (constants stored on-board, update A/D values in real-time) E = Economy Model; 250k, CAL ibration REF erence

Table 1-7: 16-Bit DAQ-PACK Model Number Structure

	16-Bit DAQ-PACK Models	# of Inputs	A/D Rate (kHz)	CAL		D/A	I/O Connector(s)	Power Required
				REF	Real-Time			
97	DPK-AI16-16A	16SE / 8 DIFF	500	YES	YES	0	68-Pin Male SCSI	5V via USB or Ext Supply
98	DPK-AI16-16E	16SE / 8 DIFF	250	YES	NO	0	68-Pin Male SCSI	5V via USB or Ext Supply
99	DPK-AI16-32A	32 DIFF	500	YES	YES	0	DB37 Female x 2	±15V, +5V
100	DPK-AI16-32E	32 DIFF	250	YES	NO	0	DB37 Female x 2	±15V, +5V
101	DPK-AI16-64A	64 DIFF	500	YES	YES	0	DB37 Female x 4	±15V, +5V
102	DPK-AI16-64E	64 DIFF	250	YES	NO	0	DB37 Female x 4	±15V, +5V
103	DPK-AI16-64MA	64SE / 32 DIFF	500	YES	YES	0	DB37 Female x 2	5V via USB or Ext Supply
104	DPK-AI16-64ME	64SE / 32 DIFF	250	YES	NO	0	DB37 Female x 2	5V via USB or Ext Supply
105	DPK-AI16-96A	96 DIFF	500	YES	YES	0	DB37 Female x 6	±15V, +5V
106	DPK-AI16-96E	96 DIFF	250	YES	NO	0	DB37 Female x 6	±15V, +5V
107	DPK-AI16-128A	128 DIFF	500	YES	YES	0	DB37 Female x 8	±15V, +5V
108	DPK-AI16-128E	128 DIFF	250	YES	NO	0	DB37 Female x 8	±15V, +5V
109	DPK-AIO16-16A	16SE / 8 DIFF	500	YES	YES	2	68-Pin Male SCSI	5V via USB or Ext Supply
110	DPK-AIO16-16E	16SE / 8 DIFF	250	YES	NO	2	68-Pin Male SCSI	5V via USB or Ext Supply
111	DPK-AIO16-32A	32 DIFF	500	YES	YES	2	DB37 Female x 2	±15V, +5V
112	DPK-AIO16-32E	32 DIFF	250	YES	NO	2	DB37 Female x 2	±15V, +5V
113	DPK-AIO16-64A	64 DIFF	500	YES	YES	2	DB37 Female x 4	±15V, +5V
114	DPK-AIO16-64E	64 DIFF	250	YES	NO	2	DB37 Female x 4	±15V, +5V
115	DPK-AIO16-64MA	64SE / 32 DIFF	500	YES	YES	2	DB37 Female x 2	5V via USB or Ext Supply
116	DPK-AIO16-64ME	64SE / 32 DIFF	250	YES	NO	2	DB37 Female x 2	5V via USB or Ext Supply
117	DPK-AIO16-96A	96 DIFF	500	YES	YES	2	DB37 Female x 6	±15V, +5V
118	DPK-AIO16-96E	96 DIFF	250	YES	NO	2	DB37 Female x 6	±15V, +5V
119	DPK-AIO16-128A	128 DIFF	500	YES	YES	2	DB37 Female x 8	±15V, +5V
120	DPK-AIO16-128E	128 DIFF	250	YES	NO	2	DB37 Female x 8	±15V, +5V

Table 1-8: 16-Bit DAQ-PACK Model Product Selector

Base Model Options

- -P External AC/DC adapter (power jack/regulator installed)
- -OEM Board only (no enclosure)
- -DIN DIN rail mounting provision
- -T Extended Temperature Operation (-40° to +85°C)

To order specific, custom current input configurations which can be any combination of differential or single-ended 4-20mA or 10-50mA inputs please contact the factory at 800-326-1649. For options specific to models including AIMUX-64 or AIMUX-32 boards, refer to Chapter 8 and 9 respectively.

Included with your board

The following components are included with your shipment depending on model and options ordered. Please take time now to ensure that no items are damaged or missing.

- USB AIO Family Module installed in an enclosure with an anti-skid bottom
- 6' USB cable
- Software Master CD (PDF user manual installed with product package)
- Printed USB I/O Quick-Start Guide

Optional accessories

- CUSB-EMB-6 6' USB Cable (type A to micro USB connector) For use with OEM versions.
- C68PS18L 68-Pin SCSI 18" shielded cable with one-touch latches
- STB-68 Screw Terminal Board (mounted on standoffs)
- STB-68-Kit Screw Terminal Board with enclosure mounting and interconnecting ribbon cable.

Chapter 2: Installation

Software CD Installation

The software provided with this board is contained on one CD and **must be installed onto your hard disk prior to use**. To do this, perform the following steps as appropriate for your operating system. Substitute the appropriate drive letter for your drive where you see D: in the examples below.

WIN2000/XP/2003

- a. Place the CD into your CD-ROM drive.
- b. The CD should automatically run the install program. If the install program does not run, click START | RUN and type `D:\INSTALL`, click OK or press `Enter`.
- c. Follow the on-screen prompts to install the software for this board.

LINUX

- a. Please refer to linux.htm on the CD-ROM for information on installing under linux.

Hardware Installation

Please install the software package **before** plugging the hardware into the system. The board can be installed in any USB 2.0 port. Please refer to the USB I/O Quick Start Guide which can be found on the CD, for specific, quick steps to complete the hardware and software installation.

Chapter 3: Hardware Details

Option Selection

You may also refer to the setup program installed from the CD provided with the board. The only user selectable hardware option available is VUSB vs. VEXT which selects between USB powered or Externally powered.

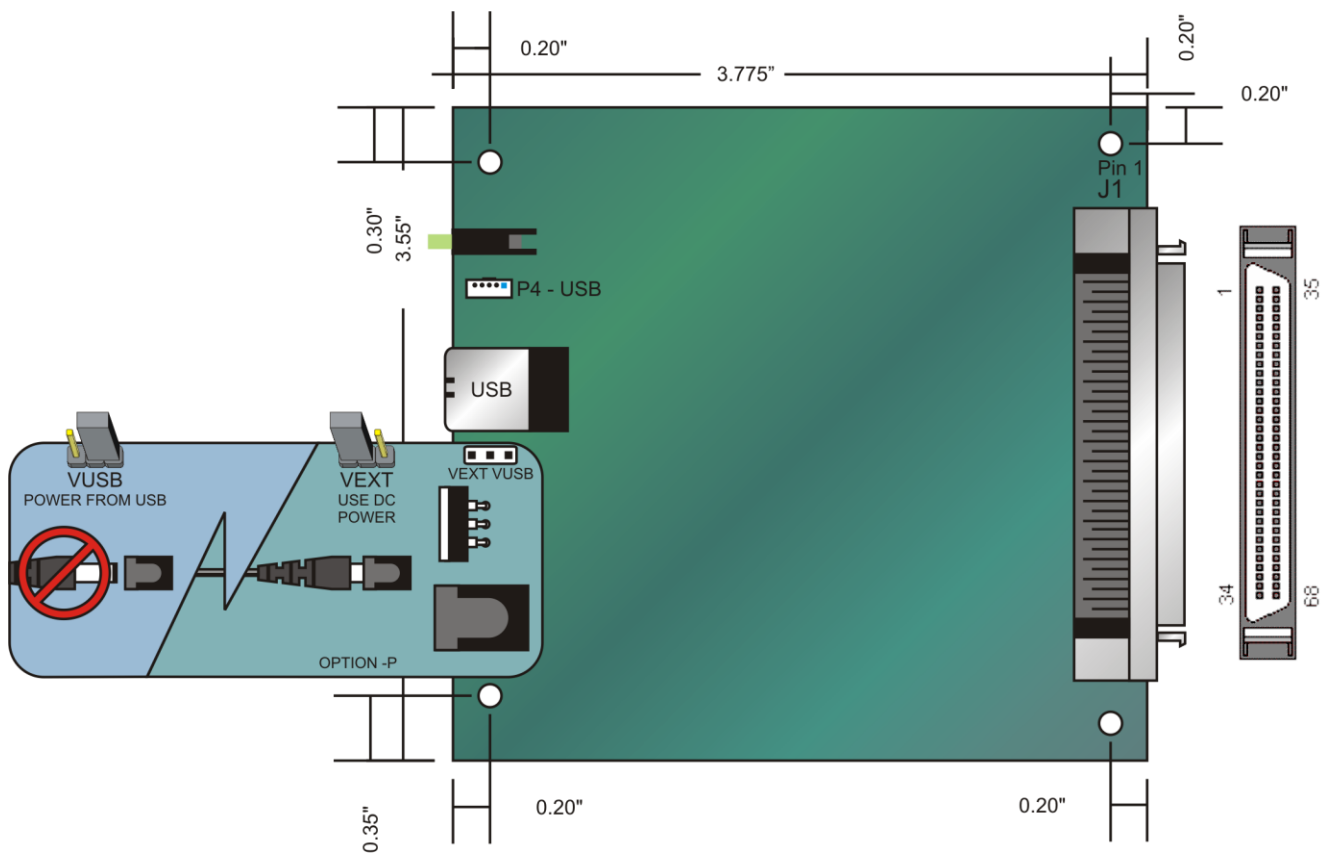

Table 3-1: Base Model Option Selection Map

USB Connector (P1)

The USB connector available via the outside of the enclosure (OEM product versions do not include enclosures) is a Type B and mates with the six-foot cable provided. The USB port provides communication signals along with +5 VDC power. The board can be powered from the USB port or an external power supply can be used. See the **DC Power Jack** description below for more details about using an external power supply.

Embedded USB Connector (P4)

In applications where the OEM (board only, no enclosure) version of this board is used, it may be desirable to use the on-board micro USB connector, which is next to the Type B connector.

LED

The LED on the front of the enclosure is used to indicate power and data transmissions. When the LED is in an illuminated steady green state, this signifies that the board is successfully connected to the computer and has been detected and configured by the operating system. When the LED flashes continuously, this signifies that there is data being transmitted over the USB bus.

DC Power Jack (Optional)

Please note, not all boards will contain this option. This is an option for applications sourcing in excess of 150mA for the DIO (each DIO line is capable of sourcing up to 32mA). The DC jack has a 2.00mm post on board and is designed to be used with the 9* VDC AC/DC external power supply that ships with this option. The voltage regulator on board regulates the 9 VDC and provides 5 VDC to the onboard circuitry. When using external power, switch the jumper located near the USB connector to VEXT, otherwise when the jumper is in the VUSB position current is drawn from the USB port (please consult the option selection map for a visual reference).

***OEM product versions require a +5 VDC external power supply instead of +9 VDC, which is provided with your shipment.**

68-Pin I/O Connector (J1)

The I/O is accessed via a 68-pin female SCSI Pin in Socket type connector with one-touch lock latches. Detailed pin assignments are listed in chapter 6, as well as a reference of pin functions printed on the enclosure label.

Chapter 4: USB Address Information

Use the provided driver to access the USB board. This driver will allow you to determine how many supported USB devices are currently installed, and each device's type. This information is returned as a Vendor ID (VID), Product ID (PID) and Device Index.

The board's VID is "0x1605", and the PID for each model is listed below: For DAQ-PACK models substitute "DPK" for "USB".

8040	USB-AI16-16A	8140	USB-AIO16-16A
8041	USB-AI16-16E	8141	USB-AIO16-16E
8042	USB-AI12-16A	8142	USB-AIO12-16A
8043	USB-AI12-16	8143	USB-AIO12-16
8044	USB-AI12-16E	8144	USB-AIO12-16E
8045	USB-AI16-64MA	8145	USB-AIO16-64MA
8046	USB-AI16-64ME	8146	USB-AIO16-64ME
8047	USB-AI12-64MA	8147	USB-AIO12-64MA
8048	USB-AI12-64M	8148	USB-AIO12-64M
8049	USB-AI12-64ME	8149	USB-AIO12-64ME
804A	USB-AI16-32A	814A	USB-AIO16-32A
804B	USB-AI16-32E	814B	USB-AIO16-32E
804C	USB-AI12-32A	814C	USB-AIO12-32A
804D	USB-AI12-32	814D	USB-AIO12-32
804E	USB-AI12-32E	814E	USB-AIO12-32E
804F	USB-AI16-64A	814F	USB-AIO16-64A
8050	USB-AI16-64E	8150	USB-AIO16-64E
8051	USB-AI12-64A	8151	USB-AIO12-64A
8052	USB-AI12-64	8152	USB-AIO12-64
8053	USB-AI12-64E	8153	USB-AIO12-64E
8054	USB-AI16-96A	8154	USB-AIO16-96A
8055	USB-AI16-96E	8155	USB-AIO16-96E
8056	USB-AI12-96A	8156	USB-AIO12-96A
8057	USB-AI12-96	8157	USB-AIO12-96
8058	USB-AI12-96E	8158	USB-AIO12-96E
8059	USB-AI16-128A	8159	USB-AIO16-128A
805A	USB-AI16-128E	815A	USB-AIO16-128E
805B	USB-AI12-128A	815B	USB-AIO12-128A
805C	USB-AI12-128	815C	USB-AIO12-128
805D	USB-AI12-128E	815D	USB-AIO12-128E

Table 4-1: Product ID to Model Number

The Device Index is determined by how many of the device you have in your system, and can provide a unique identifier* allowing you to access a specific board at will.

* See the Software Reference Manual, installed on your system along with the board support package, for more information.

Chapter 5: Programming

The driver software provided with the board uses a 32-bit .dll front end compatible with any Windows programming language. Samples provided in Borland C++Builder, Borland Delphi, Microsoft Visual Basic, and Microsoft Visual C++ demonstrate use of the driver.

Many functions are provided by the driver in Windows.

These functions will allow you to read or write to the board. In addition, counter-timer functionality and board-level functions complete the driver package.

For detailed information on each function refer to the .html Driver Manual located in the Win32 directory for this board.

unsigned long ADC_GetScanV(- This simple function takes one scan of A/D data and converts it to voltage. It also averages oversamples for each channel. The array must contain one entry per A/D channel on the board, though only entries [start channel] through [end channel] are altered.
unsigned long DeviceIndex - number from 0-31 indicating from which device you wish to get a scan of data
double *pBuf - a pointer to the first of an array of double precision IEEE floating point numbers which will each receive the value read from one channel
)

unsigned long ADC_SetConfig(
unsigned long DeviceIndex - number from 0-31 indicating to which device you wish to set the A/D configuration
unsigned char *pConfigBuf - a pointer to the first of an array of configuration bytes
unsigned long *ConfigBufSize - a pointer to a variable holding the number of configuration bytes to write. Will be set to the number of configuration bytes written
)

Software for AIMUX-xx models

The software operation of the USB-AI(O) family when combined with the AIMUX-xx remains nearly identical.

Several small things do change, however.

1) ADC_SetScanLimits() can accept channel numbers up to 128 for both the start and end channel.

2) If you choose to set your scan limits directly via the SetConfig() API, the array of configuration values has one extra byte. This byte contains the extra channel select bits for the start and end channel. Simply stated, the "high nybble" of the channel numbers are stored in the extra byte (array index 0x20). The high nybble can be calculated by dividing the channel number by 16 and dropping any fractions. In the same fashion as the normal start and end channel control index, the end-channel bits go in the top nybble, and the start channel bits go in the low nybble.

3) The data returned from any API including both ADC_BulkAcquire() and ADC_GetScanV(), just to name two, will consist of the data sequentially between the start channel and end channel, as specified in #1 or #2, above.

Chapter 6: Connector Pin Assignments

The base model uses a 68-pin Type 2 SCSI female with quick-release “one-touch” locking latches. The connector on the board is a TE Receptacle Assembly, Shielded, Right Angle, Railed, .050 Series, Amplimite, Part Number 1761028-4, or equivalent.

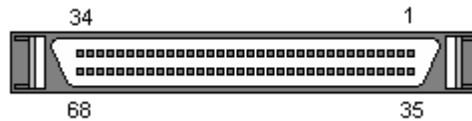

Figure 6-1: 68-Pin SCSI Connector Pin Locations

Pin	Signal Name	Pin	Signal Name
1	Ch0 (SE) / Ch0+ (DIFF)	35	Ch8 (SE) / Ch0- (DIFF)
2	AGND	36	AGND
3	Ch1 (SE) / Ch1+ (DIFF)	37	Ch9 (SE) / Ch1- (DIFF)
4	AGND	38	AGND
5	Ch2 (SE) / Ch2+ (DIFF)	39	Ch10 (SE) / Ch2- (DIFF)
6	AGND	40	AGND
7	Ch3 (SE) / Ch3+ (DIFF)	41	Ch11 (SE) / Ch3- (DIFF)
8	AGND	42	AGND
9	Ch4 (SE) / Ch4+ (DIFF)	43	Ch12 (SE) / Ch4- (DIFF)
10	AGND	44	AGND
11	Ch5 (SE) / Ch5+ (DIFF)	45	Ch13 (SE) / Ch5- (DIFF)
12	AGND	46	AGND
13	Ch6 (SE) / Ch6+ (DIFF)	47	Ch14 (SE) / Ch6- (DIFF)
14	DAC0 (AIO) / AGND (AI)	48	AGND
15	Ch7 (SE) / Ch7+ (DIFF)	49	Ch15 (SE) / Ch7- (DIFF)
16	DAC1 (AIO) / AGND (AI)	50	AGND
17	AGND	51	-15V (Factory Use)
18	MUX CTL	52	+5V
19	AGND	53	+15V (Factory Use)
20	MUX CTL	54	+5V
21	MUX CTL	55	+5V
22	GND	56	GND
23	DIO14	57	DIO15
24	DIO12	58	DIO13
25	DIO10	59	DIO11
26	DIO8	60	DIO9
27	DIO6	61	DIO7
28	DIO4	62	DIO5
29	DIO2	63	DIO3
30	DIO0	64	DIO1
31	GND	65	GND
32	Counter Output	66	GND
33	Counter Clock	67	A/D Conversion Start Enable
34	Counter Gate	68	External Trigger

Table 6-1: Base Model 68-pin SCSI Connector Pin Assignments

Signal Name	I/O	Description
Ch0 thru Ch7(SE)/Ch0+ thru Ch7+ (DIFF)	I	Channel 0 thru Channel 7 Single-ended or Channel 0 thru Channel 7 Differential non-inverting input Channel 0 thru Channel 7 Single-ended current* (+) input or Channel 0 thru Channel 7 Differential non-inverting current* (+) input
Ch8 thru Ch15(SE)/Ch0- thru Ch7-(DIFF)	I	Channel 8 thru Channel 15 Single-ended or Channel 0 thru Channel 7 Differential inverting input Channel 8 thru Channel 15 Single-ended current* (+) input or Channel 0 thru Channel 7 Differential inverting current* (-) input
AGND	X	Analog Ground Single-ended input return
+5V	I/O	+5V from AIMUX-32 board used to provide power to the USB-AIO. If no AIMUX board present, available for use. (+5V @ 100mA)
-15V	O	AIMUX-64M Power. Factory use only. Do not connect.
+15V	O	AIMUX-64M Power. Factory use only. Do not connect.
MUX CTL	O	Multiplexer control when AIMUX board(s) present
DAC0 & DAC1	O	D/A outputs for USB-AIO boards
GND	X	Digital Ground
DIO0 through DIO15	I/O	Digital I/O Bits 0 through 15, two 8-bit bytes programmed as either inputs or outputs (pulled-up to 5V through 10k ohms)
Counter Output	O	Output from 8254 ctr/tmr (pulled-up)
Counter Clock	I	8254 counter/timer clock input (pulled-up)
Counter Gate	I	8254 counter/timer gate input (pulled-up; active-high)
A/D Conversion Start Enable	I	Enable Analog to Digital Conversion Starts (pulled-up; active-high)
External Trigger	I	External Analog to Digital Conversion Start Trigger (pulled-up; software selectable rising/falling edge)
* = 4-20mA or 10-50mA Factory Optional		

Table 6-2: Base Model Signal Name, Descriptions and Directions

Chapter 7: Base Model Specifications

Analog Inputs

ADC Type	Successive approximation
Resolution	16-bit 12-bit
Sampling rate	
“16-16A” version	500k samples/sec (maximum aggregate)
“16-16E” version	250k samples/sec (maximum aggregate)
“12-16A” version	500k samples/sec (maximum aggregate)
“12-16” version	250k samples/sec (maximum aggregate)
“12-16E” version	100k samples/sec (maximum aggregate)
Number of channels	16 single-ended or 8 differential (software selectable)
Unipolar ranges	0-1V, 0-2V, 0-5V, 0-10V (software selectable)
Bipolar ranges	±1V, ±2V, ±5V, ±10V (software selectable)
4-20mA or 10-50mA	Factory installed (optional)
Calibration Hardware	
“16-16A” version	Two on-board references + calibrated real-time output
“16-16E” version	Two on-board references
“12-16A” version	Two on-board references+ calibrated real-time output
“12-16” version	Two on-board references
“12-16E” version	None
System Calibration	Program provided to calibrate entire system
Accuracy	
Uncalibrated	0.094% Full-Scale (FS)
Calibrated ⁽¹⁾	0.0015% FS
Integral Nonlinearity Error	0.0046% FS
No Missing Codes	15 bits
Input impedance	1MΩ
A/D Conv. Start Sources	Software Start, Timer Start, and External Start Trigger (rising or falling edge; software selectable)
A/D Conversion Start Enable	Externally supplied (pulled-up; active-high)
A/D Conversion Start Types	Single Channel or Scan (software selectable)
Channel Oversampling	0-255 consecutive samples/channel (software selectable)
Overvoltage protection	-40 to +55V
Crosstalk	-60dB @ 500kHz

⁽¹⁾ To achieve best accuracy, one must calibrate to their own standard.

Analog Outputs

Number of Outputs:	2
Type of Outputs:	Single-ended
Resolution:	16-bit
Unipolar Ranges:	0-10V Standard, 0-5V (factory installed)
Bipolar Ranges:	±5V, ±10V (factory installed)
Conversion Rate:	4kHz per channel
Settling Time	4us typ, 7us max; 1/4 to 3/4 scale to ±2LSBs
Output Current	±25mA per channel

Digital I/O

Lines	16, programmable as inputs or outputs in groups of 8 (pulled-up)
Input voltage	Logic low: 0V(min) to 0.8V(max) Logic high: 2V(min) to 5V(max)
Input current	±20µA (max)
Output voltage	Logic low: 0V(min) to 0.55V(max) Logic high: 2V(min) to 5V(max)
Output current	Logic low 64mA(max) sink Logic high 32mA(max) source

Counter/Timer

Type	82C54 programmable interval counter
Available Counters	Counter 0 (CTR1 and CTR2 dedicated to A/D conversion starts)
Input Frequency	10MHz (max)
Counter size	16-bit
Clock	Internal 10MHz or Externally supplied (software selectable; pulled-up)
Clock Period	100ns (min)
Clock Pulse Width High	30ns (min)
Clock Pulse Width Low	40ns (min)
Gate	Externally supplied (pulled-up; active-high)
Output	External (pulled-up)

Input/Output	
Voltage/Current	Same as Digital I/O

Environmental

Operating Temperature	0° to +70°C, optional -40° to +85°C
Storage Temperature	-40° to +105°C
Humidity	5% to 90% RH, without condensation
Board Dimensions	PC/104 format, 3.550" by 3.775" and mounting holes

Power Required	+5V at 315mA typ ¹
----------------	-------------------------------

¹ USB 2.0 spec defines a device in terms of a unit load. A unit load is defined to be 100mA. Devices drawing an absolute maximum of one unit load are considered to be low-powered and devices drawing an absolute maximum of five unit loads are considered to be high-powered. Because this spec is not strictly adhered to, it is best to verify the USB port's power capabilities before operation. This card, according to the USB 2.0 spec, is a high-powered device. An optional external power supply can be ordered if the USB port cannot support high-powered devices.

If using more than a total of 500mA, use optional 9 VDC (on board voltage regulator outputs +5 VDC to card) external power supply and **remove** VUSB jumper and place jumper on VEXT. Then plug in external power before plugging into USB port. This option will give you a total of 1000mA available.

NOTE: External Power (-P) OEM product versions ship without an enclosure and have the regulator removed to eliminate heat-sinking concerns and to prevent breakage during shipment or handling. Use only the provided +5V regulated external power supply that ships with this option to avoid damaging your instrument.

Chapter 8: Analog Input Multiplexer Model AIMUX-64

Features

- Designed to pair with any of the USB-AIO base series
- Multiplexes 64 single-ended or 32 differential analog inputs into the USB-AIO base board
- Optional Cold Junction Sensor for thermocouple measurement applications
- Optionally includes two 37-pin screw terminal board accessories
- External A/D and Counter control lines accessible from USB-AIO board
- Paired with base A/D board as OEM (no enclosure) or as DAQ-PACK M Series Data Acquisition Module

Functional Description

This board is an analog input multiplexer that mates with the USB-AIO base model series. There are a total of 64 single-ended or 32 differential analog inputs that are multiplexed down to 16 single-ended or 8 differential outputs using 4:1 multiplexers (MUX). These outputs become the inputs to the USB-AIO board and are configured by software. Channel input ranges are the same as the USB-AIO board. ***These multi-board models are factory configured, integrated and tested and are not intended to be configured or expanded in the field.***

Inherently from the 4:1 MUX used, channels are grouped in 4's. The first group would consist of channels 0, 1, 2, 3, the next group consisting of channels 4, 5, 6, 7, etc. Therefore, the software configuration for the USB-AIO board channel 0 will apply to AIMUX-64 channels 0, 1, 2, 3, USB-AIO board channel 1 will apply to AIMUX-64 channels 4, 5, 6, 7, etc.

Each group of 4 channels within the enabled set is individually software configured as either single-ended or differential. This board allows a mix of both single-ended and differential inputs. One must note, however, that a differential signal requires a pair of single-ended channels. Thus, when channel 0 is programmed as a differential input, both channels 0 and 32 (Ch0+ DIFF and Ch0- DIFF respectively) are used and not available as single-ended inputs. Also, because all four channels within a group contain the same configuration, channels 1 and 33 (Ch1+ DIFF and Ch1- DIFF respectively), 2 and 34 (Ch2+ DIFF and Ch2- DIFF respectively), and 3 and 35 (Ch3+ DIFF and Ch3- DIFF respectively) would also be configured as differential channels. Refer to this chapter in Table 8-1 and 8-2 for single-ended and differential pair inputs.

When connecting thermocouple inputs to this board, a temperature sensor is needed for Cold Junction Compensation (CJC). Channels 15 and 31 can accept a two-wire temperature sensor (LM335) to provide the CJC for the thermocouple.

The AIMUX-64 connects to the USB-AIO board through a 68-pin SCSI ribbon cable. The mating connector used on the ribbon cables are AMP P/N 786090-7 or MOLEX P/N 70498-5068, or equivalent. Analog differential inputs are accessed via two right angle DB-37 female connectors. There is a right angle DB-25 female connector for the DIO and control signals.

All other sections remain the same as described in the USB-AIO portion of this manual.

Programming Differences from Base Model

No other changes should be necessary when using the AIMUX-64.

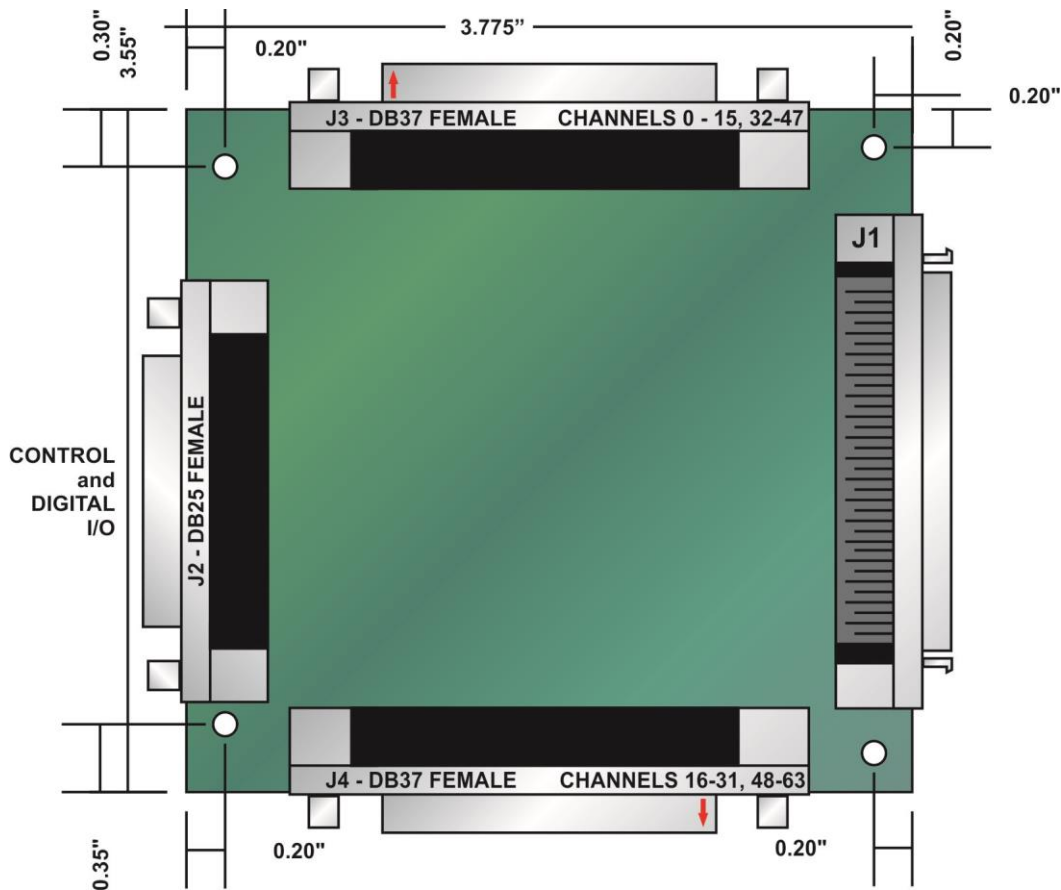

Figure 8-1: AIMUX-64 Board with Connectors

Exclusive Option for Models that include the AIMUX-64

- MTC Multiplexer Temperature Configuration includes an LM335 precision temperature sensor, with a 10k ohm resistor on one input channel to provide bias for the sensor. Also includes two universal screw terminal adaptors model ADAP-37.

Included with your board

Versions of this product that contain the AIMUX-64 ship installed in an enclosure, unless specified as –OEM, which is the board set only version.

Optional Accessories for Models that include the AIMUX-64

- ADAP37M Screw Terminal Adapter with female DB37 connector (2 needed)
- ADAP25M Screw Terminal Adapter with female DB25 connector
- Ribbon Cable assemblies
- Crimp Kit DB37 male crimp kit
- DIN-SNAP One foot length SNAP-TRACK with four clips

Adding CJC when using thermocouples with the USB-AIO family

For thermocouple inputs, a temperature sensor is needed for Cold Junction Compensation (CJC). The cold junction is the two points where the thermocouple wires attach to the connector. Each of these two points connect two dissimilar metals which, from the thermoelectric effect, cause a voltage potential (adds to thermocouple voltage and is therefore unwanted). This potential is compensated for by measuring the temperature at the terminal block using the installed temperature sensor (also known as the reference junction sensor). A look-up table is used to translate the measured temperature into a voltage. This voltage is then subtracted from the measured thermocouple voltage to compensate.

When ordering this option, the MUX board will be configured with a factory installed 10k ohm bias resistor from +15V to channels 15 and 31 input for a reference junction sensor (LM335), which is included along with two 37 pin screw terminal blocks. Connect the first LM335 Precision Temperature Sensor lead 2 (cathode) to J3-17 (channel 15) and lead 3 (anode) to AGND (preferably J3-18). Connect the second LM335 lead 2 to J4-17 (channel 31) and lead 3 to AGND (preferably J4-18). Leave both LM335's lead 1 not connected. The Cold Junction Compensation voltage can be measured on channels 15 and 31 of the AIMUX-64.

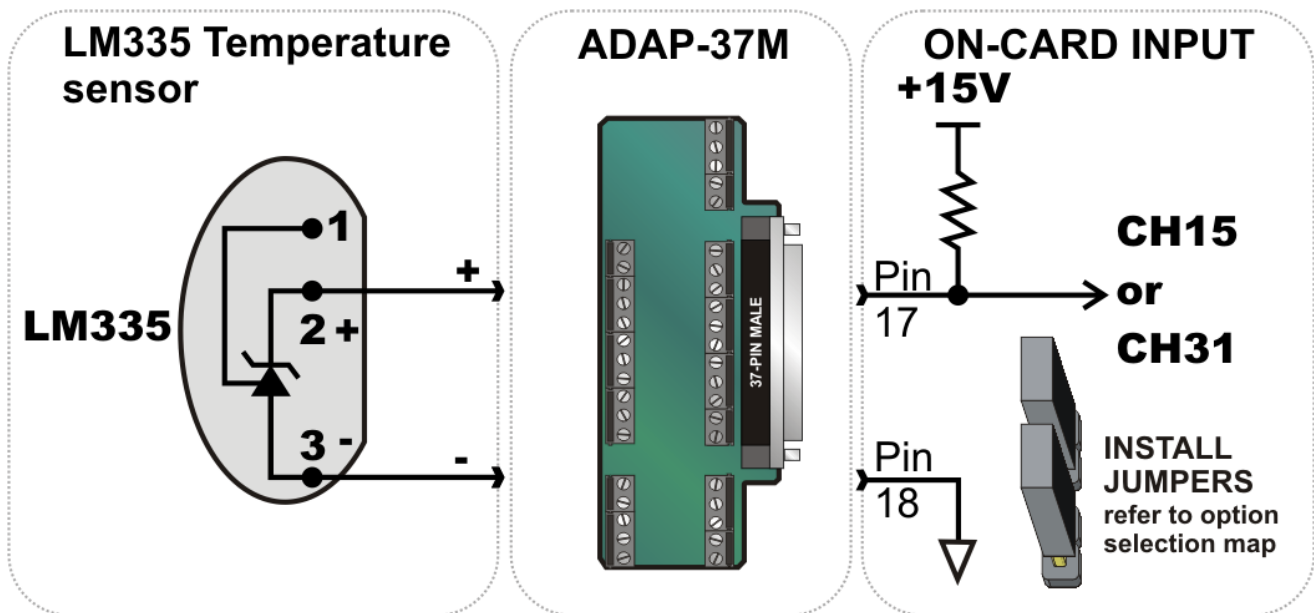

Figure 8-2: AIMUX-64 Reference Junction Temp Sensor Diagram

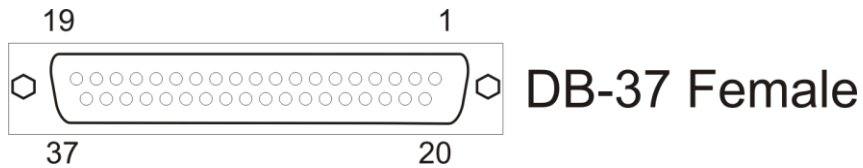

Figure 8-3: 37-Pin Female Connector Pin Locations

Pin	Signal Name	Pin	Signal Name
1	CH0(SE) / CH0+(DIFF)	20	CH32(SE) / CH0-(DIFF)
2	CH1(SE) / CH1+(DIFF)	21	CH33(SE) / CH1-(DIFF)
3	CH2(SE) / CH2+(DIFF)	22	CH34(SE) / CH2-(DIFF)
4	CH3(SE) / CH3+(DIFF)	23	CH35(SE) / CH3-(DIFF)
5	CH4(SE) / CH4+(DIFF)	24	CH36(SE) / CH4-(DIFF)
6	CH5(SE) / CH5+(DIFF)	25	CH37(SE) / CH5-(DIFF)
7	CH6(SE) / CH6+(DIFF)	26	CH38(SE) / CH6-(DIFF)
8	CH7(SE) / CH7+(DIFF)	27	CH39(SE) / CH7-(DIFF)
9	AGND	28	CH40(SE) / CH8-(DIFF)
10	CH8(SE) / CH8+(DIFF)	29	CH41(SE) / CH9-(DIFF)
11	CH9(SE) / CH9+(DIFF)	30	CH42(SE) / CH10-(DIFF)
12	CH10(SE) / CH10+(DIFF)	31	CH43(SE) / CH11-(DIFF)
13	CH11(SE) / CH11+(DIFF)	32	CH44(SE) / CH12-(DIFF)
14	CH12(SE) / CH12+(DIFF)	33	CH45(SE) / CH13-(DIFF)
15	CH13(SE) / CH13+(DIFF)	34	CH46(SE) / CH14-(DIFF)
16	CH14(SE) / CH14+(DIFF)	35	CH47(SE) / CH15-(DIFF)
17	CH15(SE) / CH15+(DIFF) / LM335+ term.	36	AGND
18	AGND / LM335- terminal	37	AGND(AI) / DAC0 (AIO)
19	AGND		

Table 8-1: AIMUX-64 J3 37-Pin Female Connector Pin Assignments

Signal Name	I/O	Description
Ch0 thru Ch31(SE)/Ch0+ thru Ch31+ (DIFF)	I	Channel 0 thru Channel 31 single-ended or Channel 0 thru Channel 31 differential non-inverting input
Ch32 thru Ch63(SE)/Ch0- thru Ch31-(DIFF)	I	Channel 32 thru Channel 63 single-ended or Channel 0 thru Channel 31 differential inverting input
LM335 + terminal	I	Temperature sensor + lead for reference junction or cold-junction compensation. When this option is ordered, Channel 1 is factory configured to provide a + bias to a provided LM335 precision temperature sensor, which should be connected to the also provided screw terminal adapter model UTBK-50.
LM335 - terminal	I	When this option is ordered, connect the – lead of the provided LM335 precision temperature sensor to the also provided screw terminal adapter model UTBK-50.
DAC0 & DAC1	O	Digital to Analog outputs
AGND	X	Analog Ground, All single-ended <i>AND</i> differential signals must have a ground reference connected on one of these pins.
GND	X	Digital Ground, Reference all digital signal devices to one of these connector pins.
DIO0 through DIO7	I/O	Digital I/O bits 0 through 7, software configured as either inputs or outputs (pulled-up to 5V through 10k ohms)
DIO8 through DIO15	O	Digital I/O bits 8 through 15, software configured as either inputs or outputs (pulled-up to 5V through 10k ohms)
Counter Output	O	Output from 8254 CTR/TMR (pulled-up)
Counter Clock	I	8254 counter/timer clock input (pulled-up)
Counter Gate	I	8254 counter/timer gate input (pulled-up; active-high)
A/D Conversion Start Enable	I	Enable Analog to Digital conversion starts (pulled-up; active-high)
External Trigger	I	External Analog to Digital conversion start trigger (pulled-up; software selectable rising/falling edge)
N/C	X	Not Connected

Table 8-4: AIMUX-64 Signal Names and Descriptions

Specifications for AIMUX-64

Analog Inputs

Number of channels 64 single-ended or 32 differential (software selectable)

MUX type 4:1

Refer to Chapter 7: Base Model Specifications for detailed specs

Analog Outputs

Number of channels 2

Refer to Chapter 7: Base Model Specifications for detailed specs

Digital I/O

Lines 16 from USB-AIO board (DIO0-DIO15)

Refer to Chapter 7: Base Model Specifications for detailed specs

Counter/Timer

Lines Gate, Clock, Output (from USB-AIO board)

Refer to Chapter 7: Base Model Specifications for detailed specs

Environmental

Power required Supplied by USB-AIO board via included 68-pin ribbon cable

All other environmental specifications, refer to Chapter 7: Base Model Specifications

Chapter 9: Signal Conditioner Model AIMUX-32

Features

- Designed to pair with any of the USB-AIO base series
- 32 differential inputs (up to 4 boards for 128 differential inputs)
- Additional ranges of 0-100mV, 0-200mV, 0-400mV, 0-500mV, 0-2.5V, $\pm 100\text{mV}$, $\pm 200\text{mV}$, $\pm 400\text{mV}$, $\pm 500\text{mV}$, $\pm 2.5\text{V}$
- Factory input signal conditioning
 - Additional ranges of 0-1mV, 0-5mV, 0-10mV, 0-20mV, 0-50mV, $\pm 1\text{mV}$, $\pm 5\text{mV}$, $\pm 10\text{mV}$, $\pm 20\text{mV}$, $\pm 50\text{mV}$
 - RC filters
 - 4-20mA and 10-50mA current inputs
 - RTD measurement
 - Bridge completion
 - Thermocouple w/ break detect (Temp sensor for cold junction)
 - Voltage divider
 - +10V sensor excitation

Functional Description

This board is an analog signal conditioner/multiplexer designed for use with the USB-AIO base series of boards. There are 32 differential analog inputs that are multiplexed down to 4 single-ended outputs using 8:1 multiplexers (MUX). These outputs become the inputs to the USB-AIO board. The inputs to the standard AIMUX-32 can be voltages or optionally 4-20mA/10-50mA current inputs. There are 10 additional input ranges with this board. They are 0-100mV, 0-200mV, 0-400mV, 0-500mV, 0-2.5V, $\pm 100\text{mV}$, $\pm 200\text{mV}$, $\pm 400\text{mV}$, $\pm 500\text{mV}$, and $\pm 2.5\text{V}$. A high gain option adds ranges of 0-1mV, 0-5mV, 0-10mV, 0-20mV, 0-50mV, $\pm 1\text{mV}$, $\pm 5\text{mV}$, $\pm 10\text{mV}$, $\pm 20\text{mV}$, and $\pm 50\text{mV}$. Furthermore, an optional voltage divider input can be factory installed for custom input ranges up to 30V. Analog inputs for the AIMUX-32 are configured and controlled by a combination of software and the gain jumpers. Up to four boards (128 differential inputs) can be used with each USB-AIO board. ***These multi-board models are factory configured, integrated and tested and are not intended to be configured or expanded in the field.***

Inherently from the 8:1 MUX used, channels are grouped in 8's. The first group would consist of channels 0,1,2,3,4,5,6,7, the next group consisting of channels 8,9,10,11,12,13,14,15, etc. Therefore, the software/jumper configuration for the USB-AIO board channel 0 will apply to AIMUX-32 channels 0,1,2,3,4,5,6,7, USB-AIO board channel 1 will apply to AIMUX-32 channels 8,9,10,11,12,13,14,15, etc.

Each input can be factory configured to accept and condition a variety of input signals. These inputs consist of RC filters, voltage dividers, thermocouples (J, K, T, E, S, R, and B), thermocouple break detect, three-wire RTD's (both 385 and 392), and installation of bridge completion resistors. A +10V source is provided for bridge and RTD excitation.

To provide a reference junction compensation for the thermocouple, channel 8 can be jumpered to accept a two-wire temperature sensor (LM335).

The AIMUX-32 connects to the USB-AIO board through a 68-pin SCSI ribbon cable. When using two or more AIMUX-32 boards a multi-SCSI ribbon cable is used. See Figure 9-1 for an illustration of this cable. Up to four AIMUX-32 boards may be connected to the USB-AIO board for a total of 128 differential analog inputs. Analog differential inputs are accessed via two right angle DB-37 female connectors. There is a right angle DB-25 female connector for the DIO and control signals.

The AIMUX-32 boards require an external +5V and ±15V to operate. A right angle 8-pin IDC header is provided on the top AIMUX-32 board to feed this power.

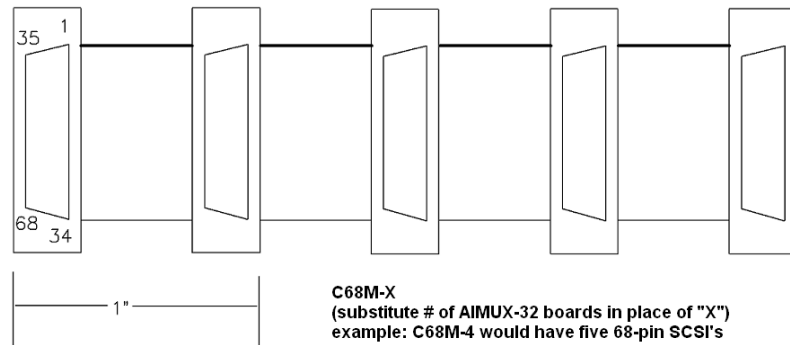

Figure 9-1: C68M-X Multi-SCSI Cable Drawing

Programming Differences from Base Model

The API functions that return voltage are unable to determine the positions of the gain jumpers as set on the submultiplexer boards. Please be aware that you would need to divide the floating-point voltage returned from these functions by the "gain factor" (x1, x2, x5, or x10) as selected for each channel's group on each AIMUX-32. It is not necessary to perform this step if you avoid the ...V() family of API functions, as all other functions return "counts", at either 12-bit or 16-bit resolution, without regard to the selected gain and range options.

Options for Models that include the AIMUX-32

- -RC RC filters; can be combined with any option or specified by itself
- -lx x=1 (32 differential inputs accepting 4-20mA)
x=2 (64 differential inputs accepting 4-20mA)
x=3 (96 differential inputs accepting 4-20mA)
x=4 (128 differential inputs accepting 4-20mA)
- -l10-50x x= as above except inputs accept 10-50mA
- -RTDx x= as above except input accept RTDs
- -BCx x= as above except inputs interface with quarter bridge configurations
- -TCx x= as above except inputs accept thermocouples. **Option includes 2 ADAP37M screw terminal adaptors and an LM335 temperature sensor per each of 32 inputs**
- -BDx x= as above except providing thermocouple break detection for each multiple of 32 inputs configured with this option (combined w/ -TCx)
- -HG High gain
- -S0x Special designator, contact factory to specify a voltage divider for your application, or to discuss any other special requirements

Optional Accessories for Models that include the AIMUX-32

- ADAP37M Screw Terminal Adapter with female DB37 connector (2 needed per AIMUX-32)
- ADAP25M Screw Terminal Adapter with female DB25 connector
- Cable Assembly
- Crimp Kit DB37 male crimp kit

Front end circuit and connection diagrams

Standard Configuration

Accepts inputs up to $\pm 10V$.

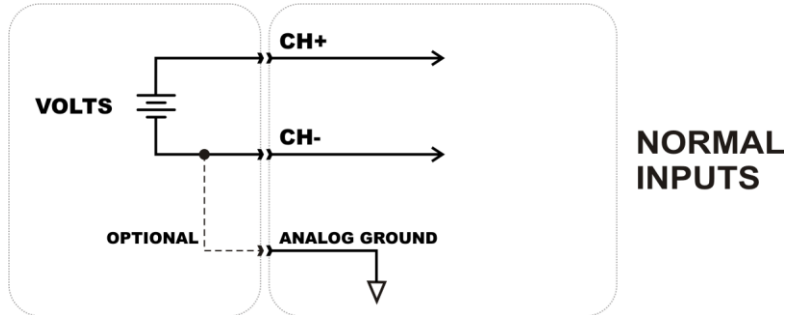

Figure 9-2: Normal Inputs

RC Filter Option

This option adds an RC filter to the inputs. It can also be added in conjunction with the other input options.

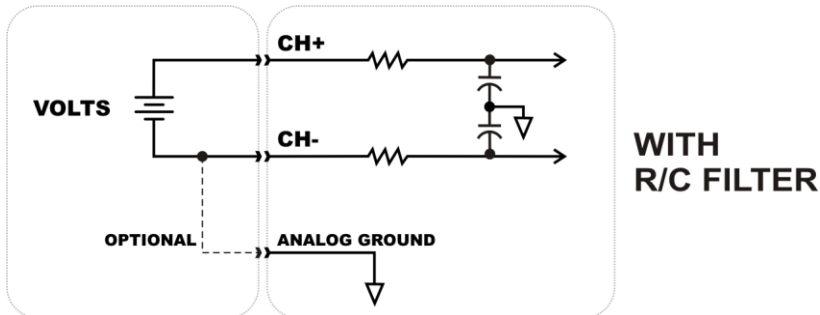

Figure 9-3: RC Filter

Input Voltage Divider (Attenuator)

The standard model configuration is intended for voltage inputs of no more than ± 10 . This input option allows voltages up to 30V using resistive voltage dividers. Input values are specified by the customer.

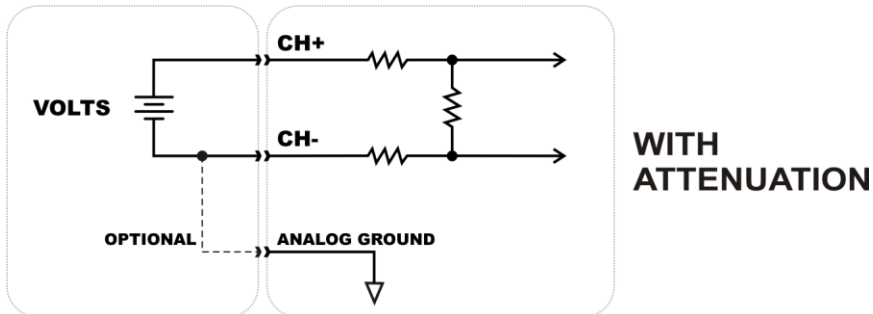

Figure 9-4: Attenuation

4-20mA/10-50mA Current Input

A precision resistor is installed from the positive input to the negative input. The input is **not** offset, so that an input will be read as 1V to 5V. Readings below 1V provide fault detection, i.e. for a blown circuit fuse.

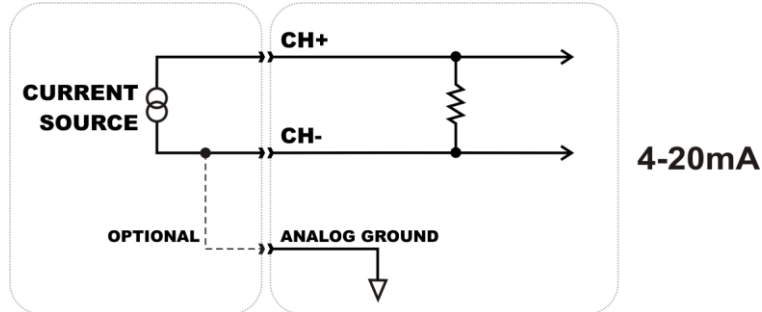

Figure 9-5: Current Input Diagram

Bridge Completion Configuration

Three resistors are installed to form three-arms of a full Wheatstone bridge. The resistor values are specified by the customer.

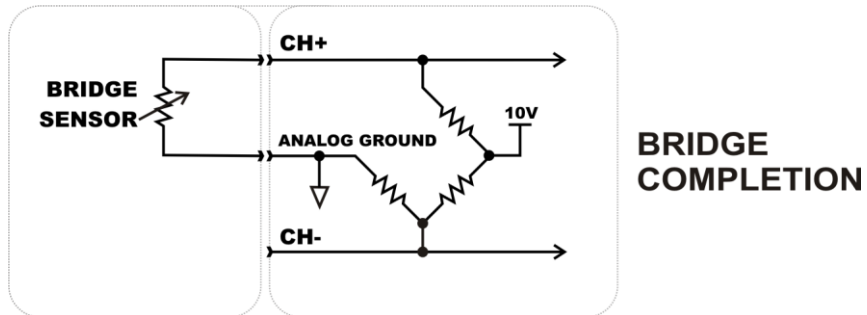

Figure 9-6: Bridge Completion Diagram

Thermocouple Measurement with reference junction temperature sensor and optional Break Detect

This option measures thermocouple inputs while also providing the temperature of the terminal block (cold junction) using a temperature sensor connected to channel 8. The optional break detect resistors can be installed to detect an open thermocouple condition (+10V on the input).

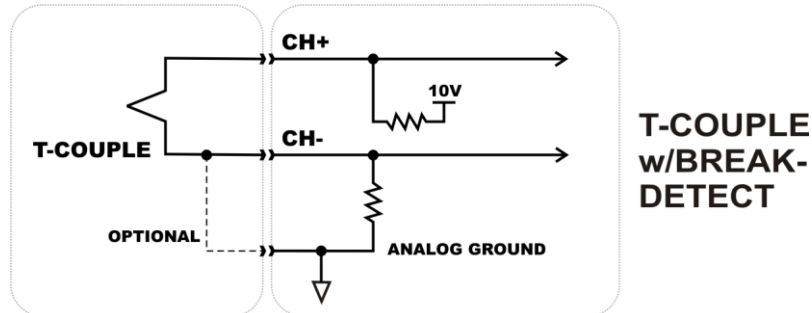

Figure 9-7: Thermocouple Input Diagram

Adding CJC when using thermocouples with the AIMUX-32

Connect the temperature sensor to J3 pin 28 for the + lead of LM335 and to pin 29 for – lead of LM335. This can be accomplished using the screw terminal adaptor ADAP37M or by soldering the temp sensor to the pins of the mating connector in your cabling.

For background information regarding the need for a reference junction sensor, please refer to the section: Adding CJC when using thermocouples with the USB-AIO family on the page with Figure 8-4: AIMUX-64 Reference Junction Temperature Sensor Diagram.

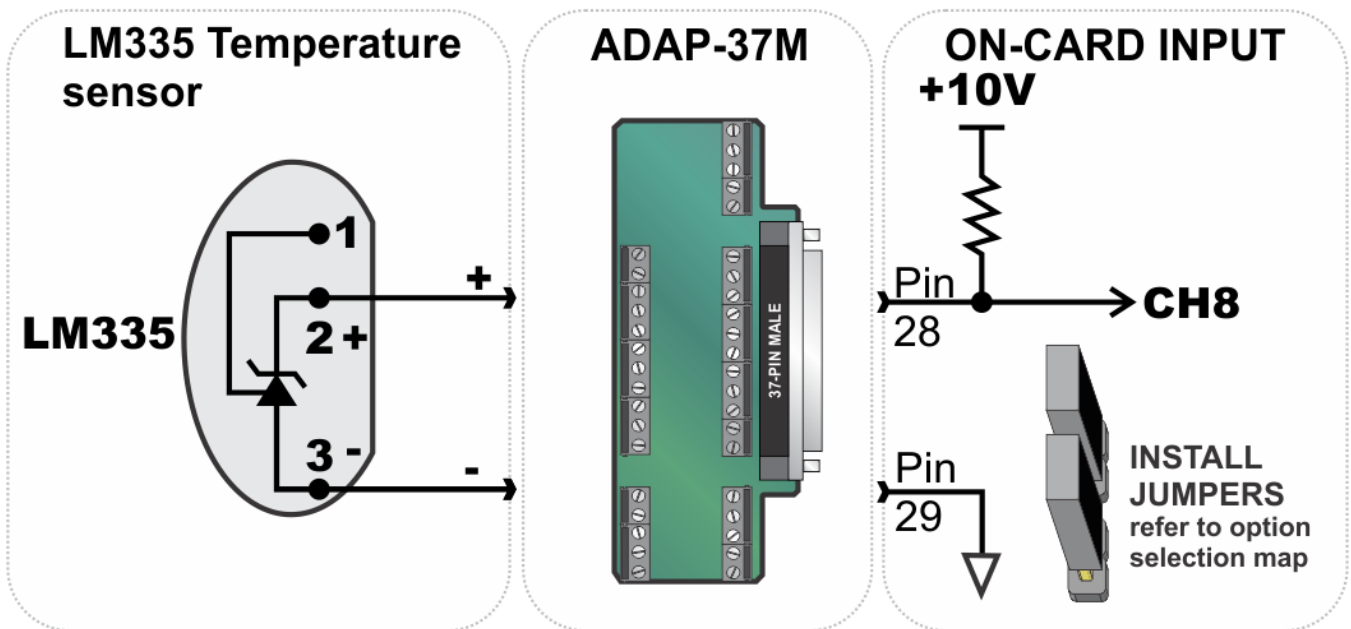

Figure 9-8: AIMUX-32 Reference Junction Temperature Sensor Diagram

RTD Measurement

The RTD option accommodates three-wire RTD's. A 66.5kΩ precision resistor in series with an RTD lead wire and the RTD sensor determines the sensor's resistance. The first 66.5kΩ resistor is connected between the +10V excitation voltage and the CH+ input. The second 66.5kΩ resistor is connected between the +10V excitation voltage and CH-. This is to provide lead length compensation. The voltage drops across the lead wires cancel at the differential signal input.

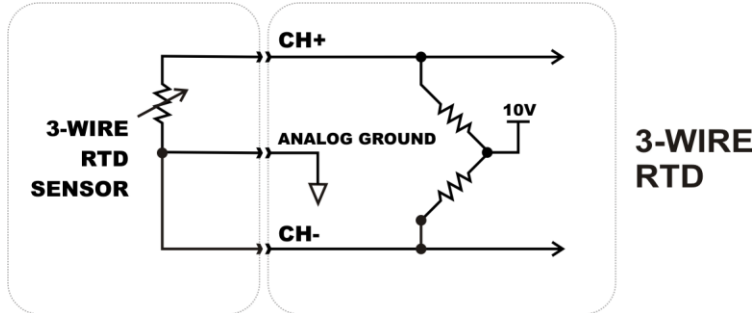

Figure 9-9: RTD Input Diagram

AIMUX-32 Hardware Details

In most cases, all jumper selections will be made at the factory prior to shipping based on pre-sales application technical support. It may be necessary to set the GAIN jumpers in the field. In the case of thermocouple applications, it is usually only necessary to have one reference junction sensor connected to provide adequate compensation. The Ch 8 Temp jumper would be connected on the Stack Position 1 board in the stack.

Option Selection

The Stack Position jumpers illustrated below select the outputs from each of four 8:1 MUX per AIMUX-32 board, which become the inputs to the USB-AIO board. The **first** AIMUX-32 board must have the jumpers installed to Stack Position 1, the **second** to Stack Position 2, etc.

The gain jumpers apply to all eight channels within the group (Group A applies to channels 0-7, Group B applies to channels 8-15, etc of the AIMUX-32 board).

Install the Ch 8 Temp. Sensor Enable jumpers to use the temperature sensor.

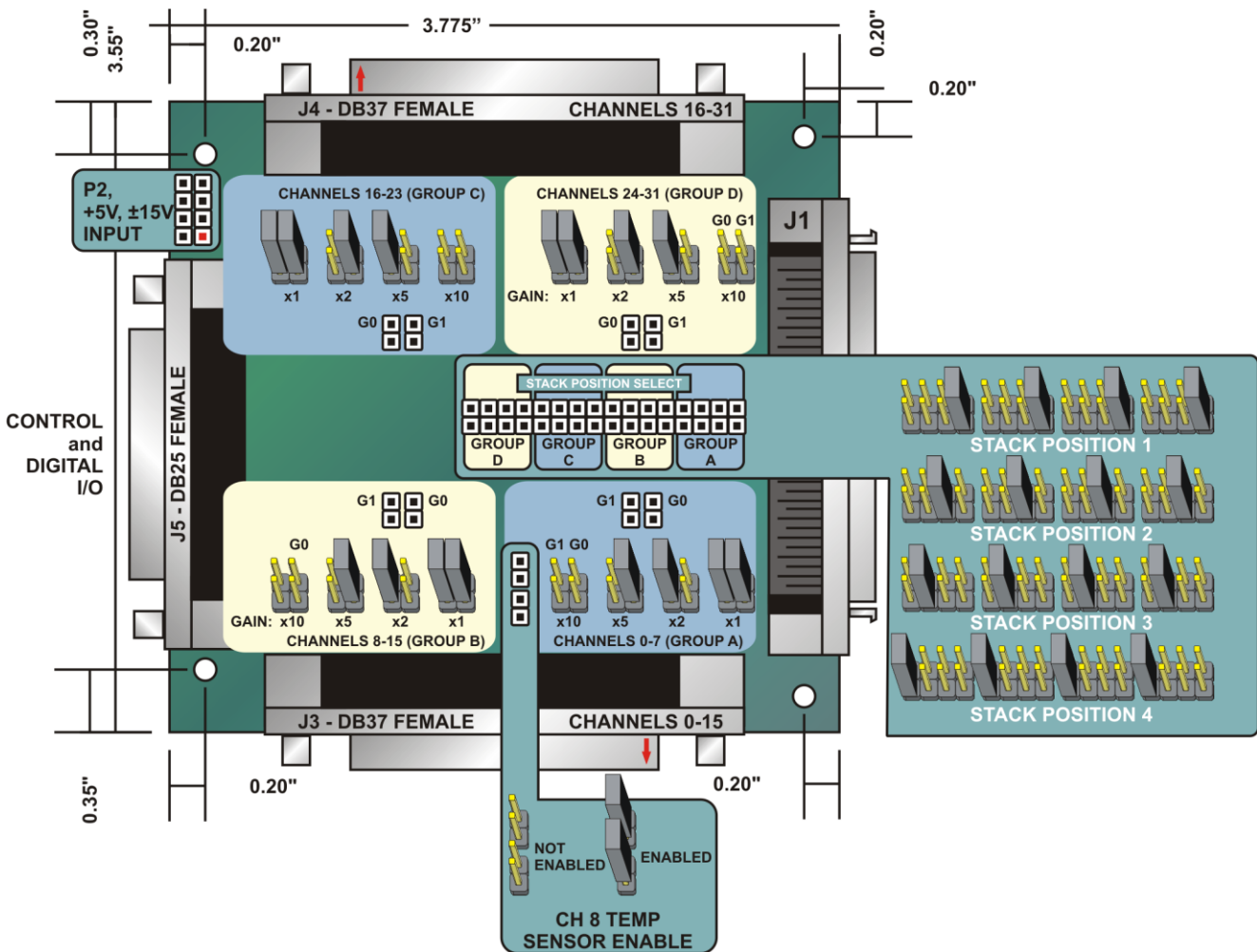

Figure 9-10: AIMUX-32 Option Selection Map

Note that in the Option Selection Map the **red pin** for the IDC connectors indicates the location of pin 1 and the **red arrows** on the DB37 connectors indicates the pin 1 location.

Controls Connectors and Indicators

J5	DB25 Female	A/D control and digital I/O
P2	8-Pin Male Header	+5V and $\pm 15V$ input power and ground
J1	68-Pin SCSI	Connects to USB-AIO board
J3	DB37 Female	Channels 0-15 analog inputs and temp sensor
J4	DB37 Female	Channels 16-31 analog inputs

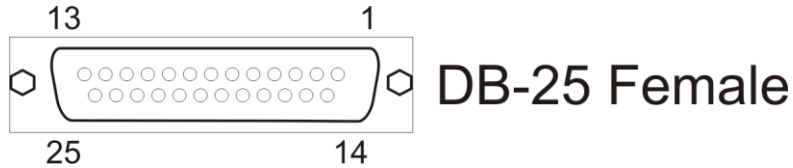

Figure 9-11: J5 DB25 Female Connector Pin Locations

Pin	Signal Name	Pin	Signal Name
1	DIO0	14	DIO12
2	DIO1	15	DIO13
3	DIO2	16	DIO14
4	DIO3	17	DIO15
5	DIO4	18	GND
6	DIO5	19	External Trigger
7	DIO6	20	A/D Conversion Start Enable
8	DIO7	21	Counter Gate
9	GND	22	Counter Clock
10	DIO8	23	Counter Output
11	DIO9	24	GND
12	DIO10	25	GND
13	DIO11		

Table 9-1: AIMUX-32 J5 DB25 Female Connector Pin Assignments

Signal Name	I/O	Description
AGND	x	Analog Ground
Counter Gate	I	External A/D Enable / Counter Gate Input (pulled-up, active-high)
External Trigger	I	Ext A/D Conversion Start Trigger (pulled-up, SW selectable for rising or falling edge)
A/D Conversion Start Enable	I	External A/D Conversion Start Enable (pulled-up, active-high)
Counter Clock	I	8254 Counter/Timer Clock Input (pulled-up)
Counter Output	O	8254 Counter/Timer Output (pulled-up)

Table 9-2: AIMUX-32 J5 Signal Names and Descriptions

Powering the AIMUX-32 boards

The AIMUX-32 signal conditioning board uses more power than can be provided from the DC/DC converter installed on the USB-AIO family board over the 68 pin ribbon cable. The 8-pin header connector is used to provide the +5V and ± 15 VDC that is required for the instrumentation amplifiers and multiplexer on the AIMUX-32 board.

Pin	Signal Name	Pin	Signal Name
1	-15V	2	-15V
3	AGND	4	AGND
5	+5V	6	+5V
7	+15V	8	+15V

Table 9-3: AIMUX-32 P2 Power Connector (IDC-8)

Signal Name	I/O	Description
-15V	I	Power Supply Input -15VSS
+5V	I	Power Supply Input +5VDC
+15V	I	Power Supply Input +15VDD

Table 9-4: AIMUX-32 P2 Signal Names and Descriptions

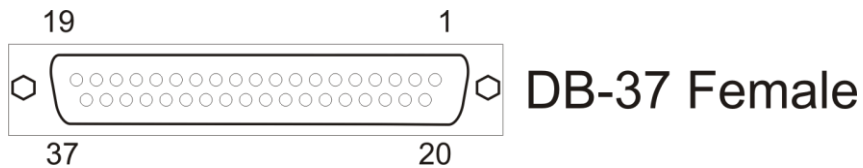

Figure 9-12: DB37 Connector Pin Locations

Pin	Signal Name	Pin	Signal Name
1	CH0+	20	CH0-
2	CH1+	21	CH1-
3	CH2+	22	CH2-
4	CH3+	23	CH3-
5	CH4+	24	CH4-
6	CH5+	25	CH5-
7	CH6+	26	CH6-
8	CH7+	27	CH7-
9	AGND	28	TEMP+ (LM335) (CH8+)
10	CH8+	29	CH8- TEMP- AGND
11	CH9+	30	CH9-
12	CH10+	31	CH10-
13	CH11+	32	CH11-
14	CH12+	33	CH12-
15	CH13+	34	CH13-
16	CH14+	35	CH14-
17	CH15+	36	CH15-
18	AGND / DAC1 return	37	DAC1
19	AGND		

Table 9-5: AIMUX-32 J3 Connector Pin Assignments (DB37F)

Signal Name	I/O	Description
CH0+ to CH15+	I	Channel 0 through 15 differential non-inverting input
CH0- to CH15-	I	Channel 0 through 15 differential inverting input
AGND	x	Analog Ground, All single-ended <i>AND</i> differential signals must have a ground reference connected on one of these pins.
TEMP+ (LM335) (CH8+)	I	Temperature sensor input circuit (LM335 + lead) when TEMP1 jumper is installed. Connected to channel 8 differential non-inverting input
DAC1	O	Digital to Analog Output 1
AGND / DAC1 return	x	DAC1's ground when installed. Otherwise, Analog Ground

Table 9-6: AIMUX-32 J3 Signal Names and Descriptions

Pin	Signal Name	Pin	Signal Name
1	CH16+	20	CH16-
2	CH17+	21	CH17-
3	CH18+	22	CH18-
4	CH19+	23	CH19-
5	CH20+	24	CH20-
6	CH21+	25	CH21-
7	CH22+	26	CH22-
8	CH23+	27	CH23-
9	AGND	28	N/C
10	CH24+	29	CH24-
11	CH25+	30	CH25-
12	CH26+	31	CH26-
13	CH27+	32	CH27-
14	CH28+	33	CH28-
15	CH29+	34	CH29-
16	CH30+	35	CH30-
17	CH31+	36	CH31-
18	AGND / DAC0 return	37	DAC0
19	AGND		

Table 9-7: AIMUX-32 J4 Connector Pin Assignments (DB37F)

Signal Name	I/O	Description
CH16+ to CH 31+	I	Channel 16 through 31 differential non-inverting inputs
CH16- to CH31-	I	Channel 16 through 31 differential inverting inputs
AGND	x	Analog Ground
DAC0	O	Digital to Analog Output 0
AGND / DAC0 return	x	DAC0's ground when installed. Otherwise, Analog Ground
N/C	I	Not Connected

Table 9-8: AIMUX-32 J4 Signal Names and Descriptions

Refer to Table 9-9, Table 9-10 and Figure 9-13 for help in gaining an understanding of what channels are on what connectors and on which board in the integrated stack.

Pin	Stack Pos.1	Stack Pos.2	Stack Pos.3	Stack Pos.4	Pin	Stack Pos.1	Stack Pos.2	Stack Pos.3	Stack Pos.4
1	CH0+	CH32+	CH64+	CH96+	20	CH0-	CH32-	CH64-	CH96-
2	CH1+	CH33+	CH65+	CH97+	21	CH1-	CH33-	CH65-	CH97-
3	CH2+	CH34+	CH66+	CH98+	22	CH2-	CH34-	CH66-	CH98-
4	CH3+	CH35+	CH67+	CH99+	23	CH3-	CH35-	CH67-	CH99-
5	CH4+	CH36+	CH68+	CH100+	24	CH4-	CH36-	CH68-	CH100-
6	CH5+	CH37+	CH69+	CH101+	25	CH5-	CH37-	CH69-	CH101-
7	CH6+	CH38+	CH70+	CH102+	26	CH6-	CH38-	CH70-	CH102-
8	CH7+	CH39+	CH71+	CH103+	27	CH7-	CH39-	CH71-	CH103-
9	AGND	AGND	AGND	AGND	28	TEMP+ (LM335)	AGND	AGND	AGND
10	CH8+	CH40+	CH72+	CH104+	29	CH8- TEMP-	CH40-	CH72-	CH104-
11	CH9+	CH41+	CH73+	CH105+	30	CH9-	CH41-	CH73-	CH105-
12	CH10+	CH42+	CH74+	CH106+	31	CH10-	CH42-	CH74-	CH106-
13	CH11+	CH43+	CH75+	CH107+	32	CH11-	CH43-	CH75-	CH107-
14	CH12+	CH44+	CH76+	CH108+	33	CH12-	CH44-	CH76-	CH108-
15	CH13+	CH45+	CH77+	CH109+	34	CH13-	CH45-	CH77-	CH109-
16	CH14+	CH46+	CH78+	CH110+	35	CH14-	CH46-	CH78-	CH110-
17	CH15+	CH47+	CH79+	CH111+	36	CH15-	CH47-	CH79-	CH111-
18	AGND	AGND	AGND	AGND	37	DAC1	DAC1	DAC1	DAC1
19	AGND	AGND	AGND	AGND					

Table 9-9: AIMUX-32 J3 DB37 Pin-outs w/CH# per Board Stack Position

Pin	Stack Pos.1	Stack Pos.2	Stack Pos.3	Stack Pos.4	Pin	Stack Pos.1	Stack Pos.2	Stack Pos.3	Stack Pos.4
1	CH16+	CH48+	CH80+	CH112+	20	CH16-	CH48-	CH80-	CH112-
2	CH17+	CH49+	CH81+	CH113+	21	CH17-	CH49-	CH81-	CH113-
3	CH18+	CH50+	CH82+	CH114+	22	CH18-	CH50-	CH82-	CH114-
4	CH19+	CH51+	CH83+	CH115+	23	CH19-	CH51-	CH83-	CH115-
5	CH20+	CH52+	CH84+	CH116+	24	CH20-	CH52-	CH84-	CH116-
6	CH21+	CH53+	CH85+	CH117+	25	CH21-	CH53-	CH85-	CH117-
7	CH22+	CH54+	CH86+	CH118+	26	CH22-	CH54-	CH86-	CH118-
8	CH23+	CH55+	CH87+	CH119+	27	CH23-	CH55-	CH87-	CH119-
9	AGND	AGND	AGND	AGND	28	N/C	N/C	N/C	N/C
10	CH24+	CH56+	CH88+	CH120+	29	CH24-	CH56-	CH88-	CH120-
11	CH25+	CH57+	CH89+	CH121+	30	CH25-	CH57-	CH89-	CH121-
12	CH26+	CH58+	CH90+	CH122+	31	CH26-	CH58-	CH90-	CH122-
13	CH27+	CH59+	CH91+	CH123+	32	CH27-	CH59-	CH91-	CH123-
14	CH28+	CH60+	CH92+	CH124+	33	CH28-	CH60-	CH92-	CH124-
15	CH29+	CH61+	CH93+	CH125+	34	CH29-	CH61-	CH93-	CH125-
16	CH30+	CH62+	CH94+	CH126+	35	CH30-	CH62-	CH94-	CH126-
17	CH31+	CH63+	CH95+	CH127+	36	CH31-	CH63-	CH95-	CH127-
18	AGND	AGND	AGND	AGND	37	DAC0	DAC0	DAC0	DAC0
19	AGND	AGND	AGND	AGND					

Table 9-10: AIMUX-32 J4 DB37 Pin-outs w/CH# per Board Stack Position

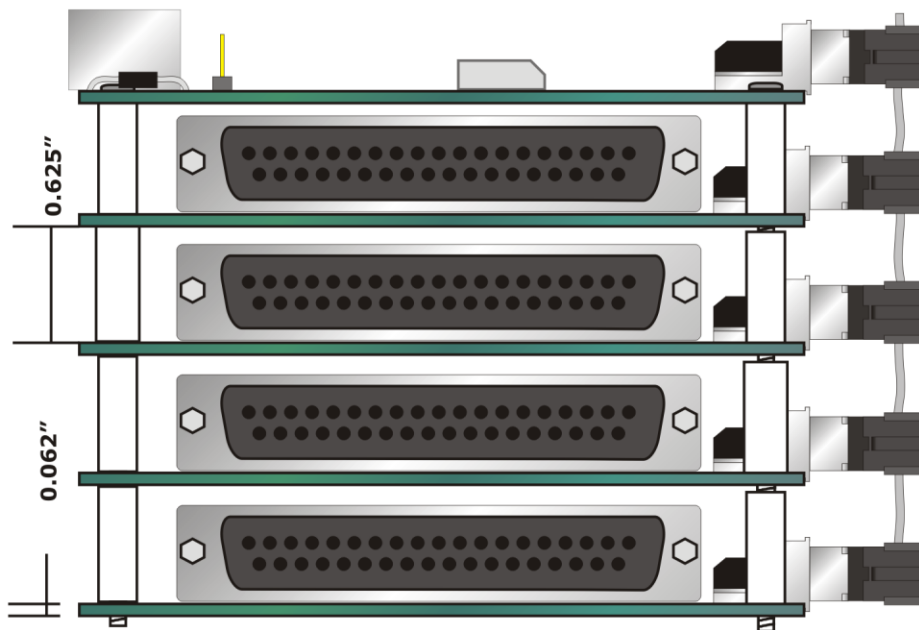
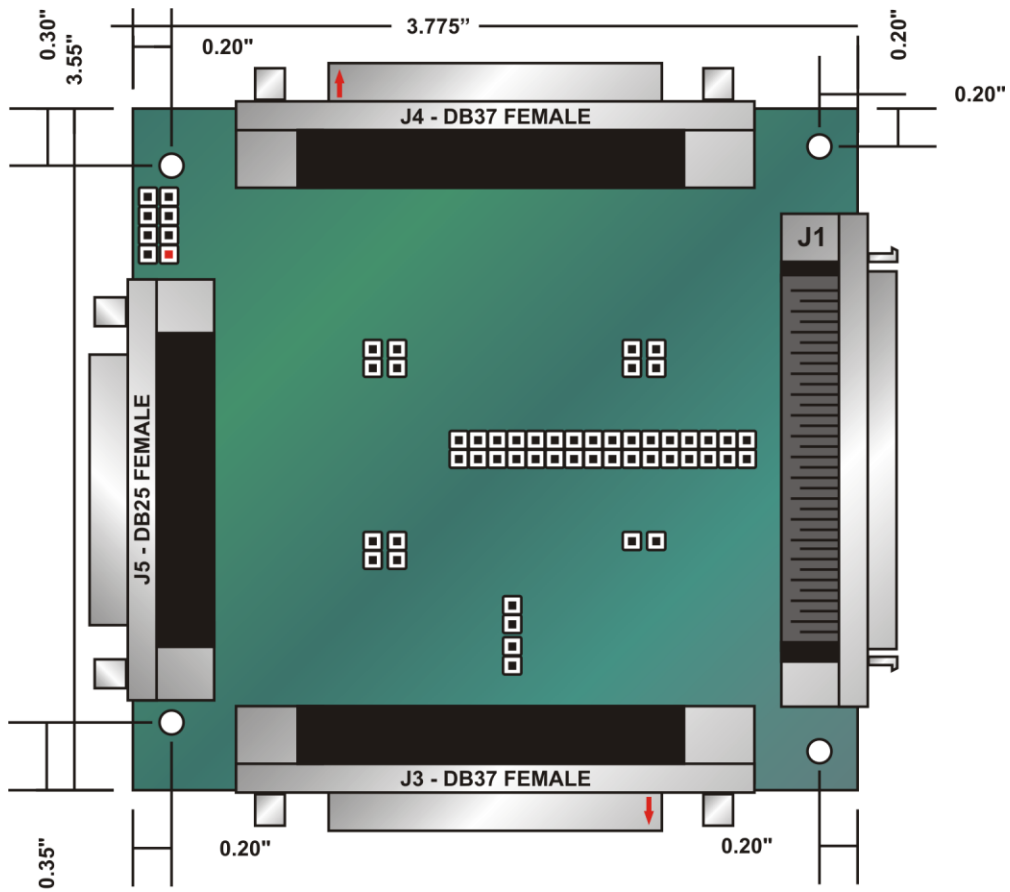

Figure 9-13: USB-AIOxx-128A Mechanical Drawing

AIMUX-32 Specification

Analog Inputs

Number of channels	32 differential per board; up to four boards or 128 differential
Voltage ranges	Additional ranges of 0-100mV, 0-200mV, 0-400mV, 0-500mV, 0-2.5V, $\pm 100\text{mV}$, $\pm 200\text{mV}$, $\pm 400\text{mV}$, $\pm 500\text{mV}$, $\pm 2.5\text{V}$ or 0-1mV, 0-5mV, 0-10mV, 0-20mV, 0-50mV, $\pm 1\text{mV}$, $\pm 5\text{mV}$, $\pm 10\text{mV}$, $\pm 20\text{mV}$, $\pm 50\text{mV}$
Current inputs	4-20mA, 10-50mA
Max voltage (divider)	Up to 30V
Input impedance	1M Ω
Sensor excitation voltage	+10V

Environmental

Operating Temperature	0° to +70°C, optional -40° to +85°C
Storage Temperature	-40° to +105°C
Humidity	5% to 90% RH, without condensation
Board Dimensions	PC/104 format, 3.550" by 3.775" and mounting holes
Power required	+5V at 315mA typ. +15V at 39mA typ. -15V at 21mA typ.

Appendix A: Counter/Timer

This board contains a 82C54 16-bit counter/timer. It can be programmed to any count as low as 1 or 2, and up to 65,536, depending on the mode chosen. For those interested in more detailed information, a full description can be found in the Intel (or equivalent manufacturer's) data sheet, provided in the /chipdocs directory on the Software Master CD.

In addition, the driver and firmware on the board requires a full 16-bit load operation; do not select "low -byte only" or "high-byte only" modes for the counters.

Additional low-level information on the 82C54 can be found on the Software Master CD in the /chipdocs directory.

Operational Modes

The 8254 modes of operation are described in the following paragraphs to familiarize you with the versatility and power of this device. For those interested in more detailed information, a full description of the 8254 programmable interval timer can be found in the Intel (or equivalent manufacturers') data sheets. The following conventions apply for use in describing operation of the 8254 :

Clock: A positive pulse into the counter's clock input

Trigger: A rising edge input to the counter's gate input

Counter Loading: Programming a binary count into the counter

Mode 0: Pulse on Terminal Count

After the counter is loaded, the output is set low and will remain low until the counter decrements to zero. The output then goes high and remains high until a new count is loaded into the counter. A trigger enables the counter to start decrementing.

Mode 1: Retriggerable One-Shot

The output goes low on the clock pulse following a trigger to begin the one-shot pulse and goes high when the counter reaches zero. Additional triggers result in reloading the count and starting the cycle over. If a trigger occurs before the counter decrements to zero, a new count is loaded. This forms a retriggerable one-shot. In mode 1, a low output pulse is provided with a period equal to the counter count-down time.

Mode 2: Rate Generator

This mode provides a divide-by-N capability where N is the count loaded into the counter. When triggered, the counter output goes low for one clock period after N counts, reloads the initial count, and the cycle starts over. This mode is periodic, the same sequence is repeated indefinitely until the gate input is brought low. This mode also works well as an alternative to mode 0 for event counting.

Mode 3: Square Wave Generator

This mode operates like mode 2. The output is high for half of the count and low for the other half. If the count is even, then the output is a symmetrical square wave. If the count is odd, then the output is high for $(N+1)/2$ counts and low for $(N-1)/2$ counts. Periodic triggering or frequency synthesis are two possible applications for this mode. Note that in this mode, to achieve the square wave, the counter decrements by two for the total loaded count, then reloads and decrements by two for the second part of the wave form.

Mode 4: Software Triggered Strobe

This mode sets the output high and, when the count is loaded, the counter begins to count down. When the counter reaches zero, the output will go low for one input period. The counter must be reloaded to repeat the cycle. A low gate input will inhibit the counter.

Mode 5: Hardware Triggered Strobe

In this mode, the counter will start counting after the rising edge of the trigger input and will go low for one clock period when the terminal count is reached. The counter is retriggerable. The output will not go low until the full count after the rising edge of the trigger.

Appendix B: Calibration

An inherent property of any ADC-based system is they all contain offset, gain, and others errors. Sources of these errors are multiplexers, amplifiers, ADC's, resistors, etc. These errors lead to inaccurate A/D data which is undesirable.

The two most common error types is offset and gain. Positive Offset Errors are illustrated in the 2nd graph from the left in Figure 9-14 (assume a 16-bit ADC). Ideally, applying zero scale to the input would yield a code of 0x0000. Any deviation from a 0x0000 code when applying zero scale to the input is the offset error.

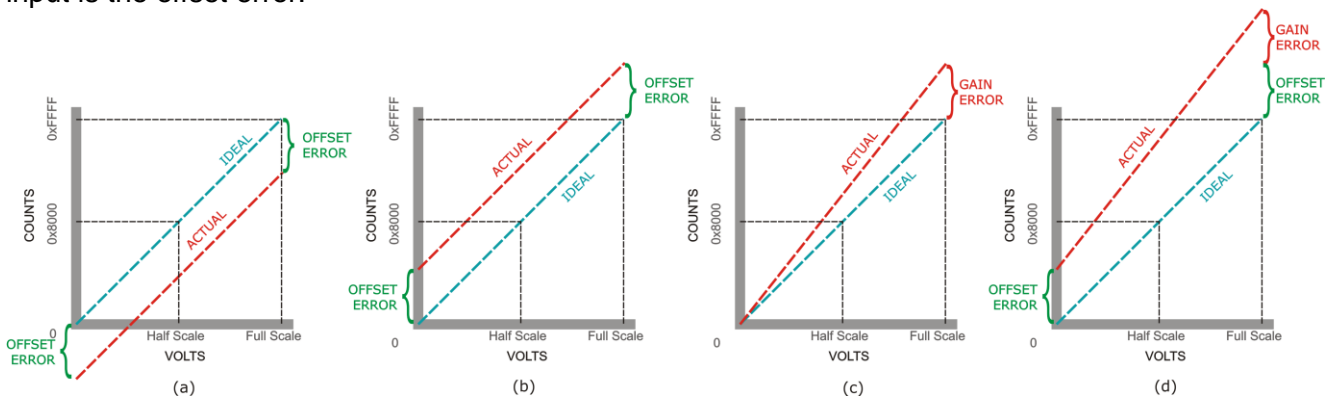

Figure 9-14: Offset and Gain Error Graphs

Gain errors are illustrated in graph (b) in Figure 9-14. The ideal slope for an ADC is a straight line passing through each point of a voltage and its associated code starting at zero scale and ending at full scale. Any deviation from a 0xFFFF code when applying full scale to the input yields a slope different than the ideal slope. The differences in these slopes is the gain error.

Graph (d) in Figure 9-14 shows how the combination of offset and gain errors can cause the actual transfer characteristic to deviate a fair amount from the ideal transfer characteristic. To account for these errors, the board includes hardware that can be used to calibrate the data and give a more accurate reading.

The first thing the hardware does is remove any negative offset error the board might have. Negative offset, shown in graph (a) in Figure 9-14, prevents the ability to measure a zero scale input. This means a 0x0000 code will be read until the input voltage exceeds the negative offset. Hardware on this board injects a small, positive, bias voltage that ensures the removal of any negative offset ("12-xxE" do not include this hardware).

Next, the board's hardware includes two on-board reference voltages (Note: "12-xxE" boards do not contain the on-board reference voltages) that can be sampled by software and used to calibrate out the offset and gain errors. The theory behind using two reference voltages to calibrate out offset and gain errors is the following:

In an ideal ADC-based system, the input voltage to the ADC, x , would be equal to the value read, y , after sampling.

So $y = x$

However, the offset and gain error graphs in Figure 9-14 illustrate that actual data does not equal the expected (ideal) data. The difference in the actual data vs. the expected data is expressed by the equation

$$y = mx + b$$

where y -> calibrated value

m -> gain factor

x -> measured value

b -> offset factor

m and b are found by sampling a reference slightly above zero scale and a reference slightly below full scale. The reason for not using a reference equal to zero scale is to avoid any negative offset error that might be present as described above. The concept is similar for using a reference not equal to full scale. A gain error could cause a reference equal to full scale to be amplified above a voltage of full scale. This gain error would not be detected as the data would report a code of 0xFFFF (any value above full scale reports this code). Therefore, choosing a reference that is guaranteed to be slightly below full scale is necessary.

This card's first on-board reference is analog ground which is used as the near zero scale reference. The small, positive, bias voltage mentioned above guarantees that the resulting data will read slightly above zero scale. This value is the offset factor and becomes the new calibrated "zero". It's represented in the equation above as

b = negative value measured for analog ground

The second on-board reference, V_{ref} , is used as the near full scale reference. V_{ref} is a value guaranteed to be slightly below full scale. The resulting data from sampling V_{ref} is used to calculate m as

$$m = \frac{\text{expected } V_{ref}}{[(\text{measured } V_{ref}) - (\text{measured analog ground value})]}$$

The exact value of V_{ref} is measured at the factory with an accurate voltmeter and the value is stored on-board which is used for the expected V_{ref} value.

Once both references have been measured and the resulting values substituted into the equations earlier in this section, software can begin sampling channels. Software then performs some post processing by applying the equations to the sampled data and the result is accurate, calibrated data.

Lastly, the 'A' model boards contain hardware that will provide real-time calibrated data. This hardware requires a file to be created by software with the offset and gain factor values. The file is then loaded onto the board and used by hardware to give real-time calibrated data. User-defined offset and gain factors can be used for custom calibration needs. Refer to the Software Reference manual for the file format. Autocalibration is a function in software that, when called, will automatically sample the two on-board references, create the calibration file, and store the calibrated information onto the board. Autocalibration can be performed in milliseconds and is recommended to be performed periodically. For optimum calibrated data, the software function should be repeated anytime the temperature or environment changes.

System Calibration Utility

This is a program provided to manually calibrate out offset, gain, and other errors for the entire system periodically. The system includes the USB-AIO board and such devices as sensors, signal conditioners, etc. These components contribute to errors in the system which lead to erroneous data. The System Calibration Utility corrects the errors for all the components in the system and provides accurate calibrated data. Following is a series of screenshots intended to provide an overview of what is involved in performing system calibration using this utility.

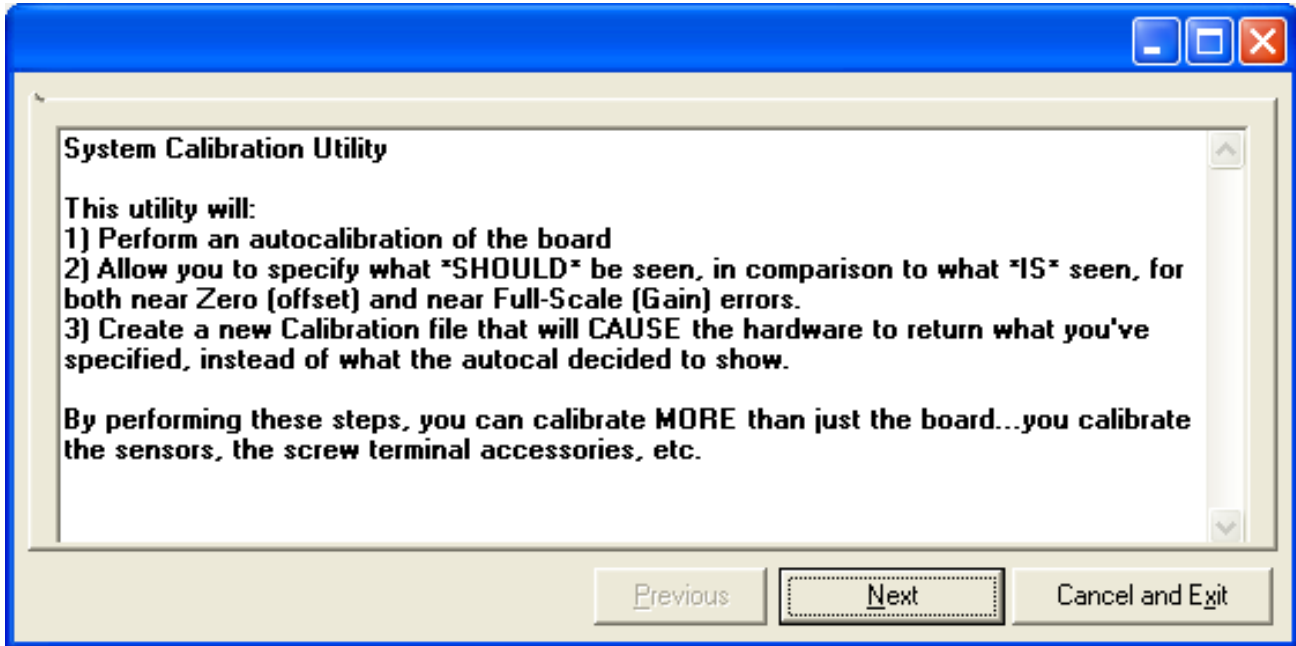

Figure 9-15: System Calibration Utility Screenshot 1 (setup)

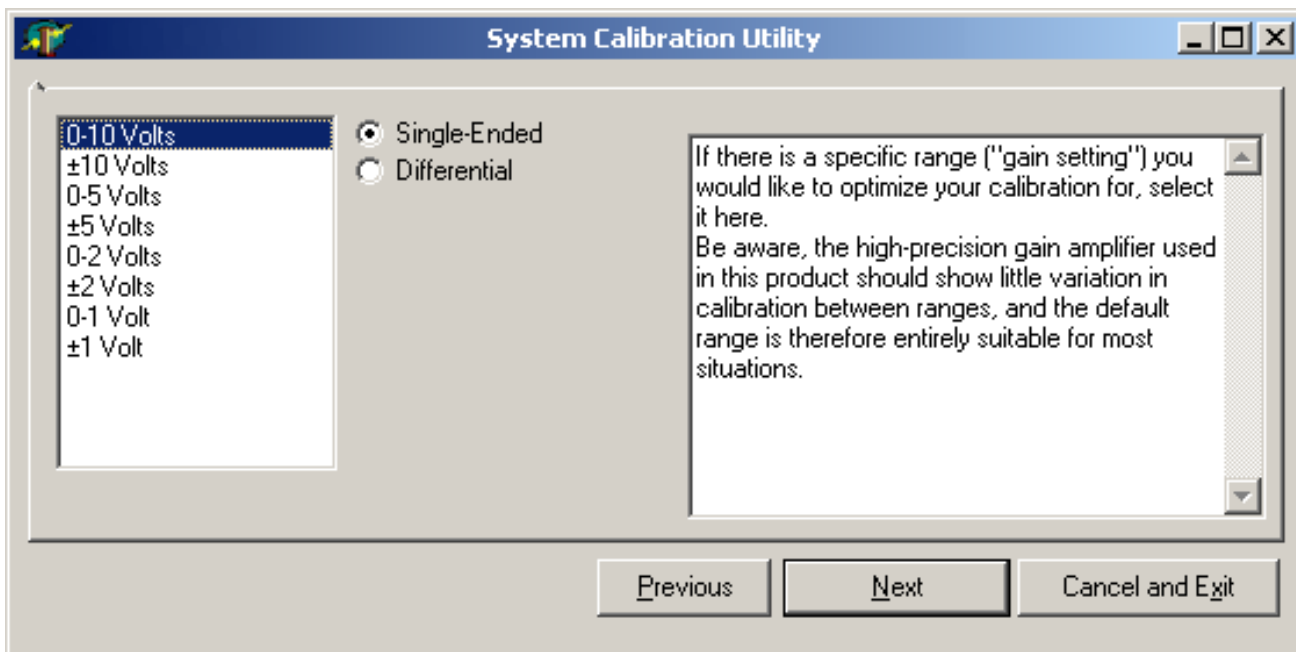

Figure 9-16: System Calibration Utility Screenshot 2 (range select)

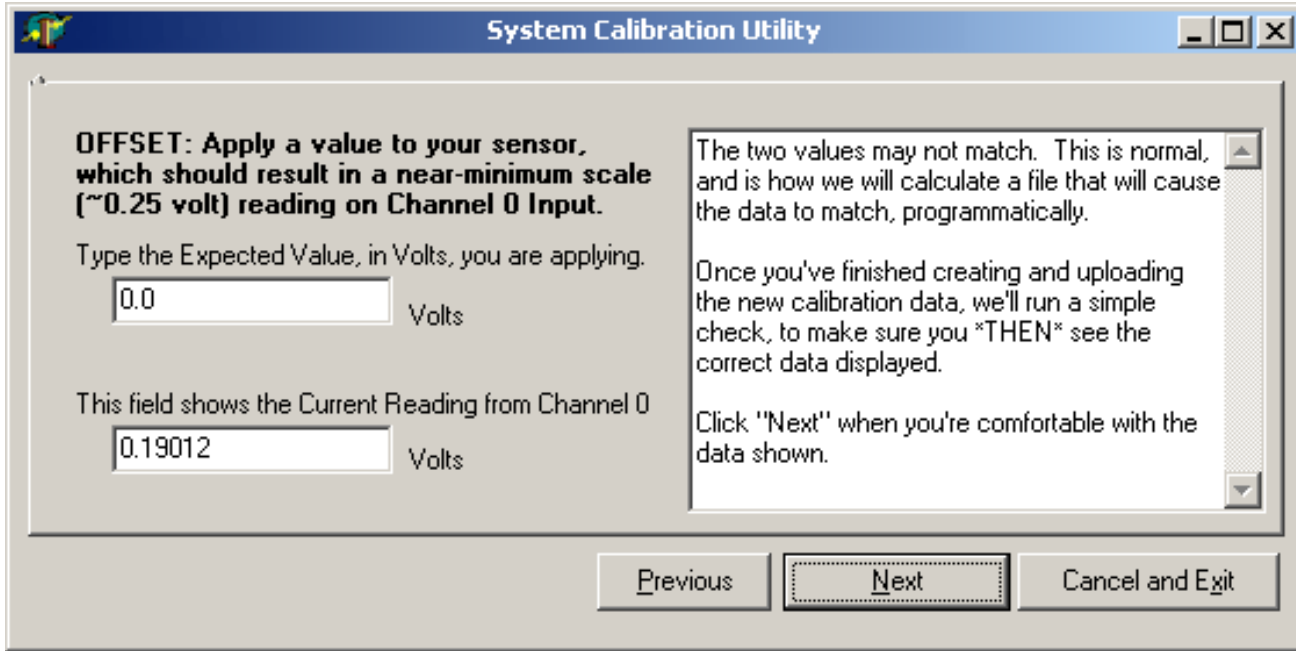

Figure 9-17: System Calibration Utility Screenshot 3 (offset)

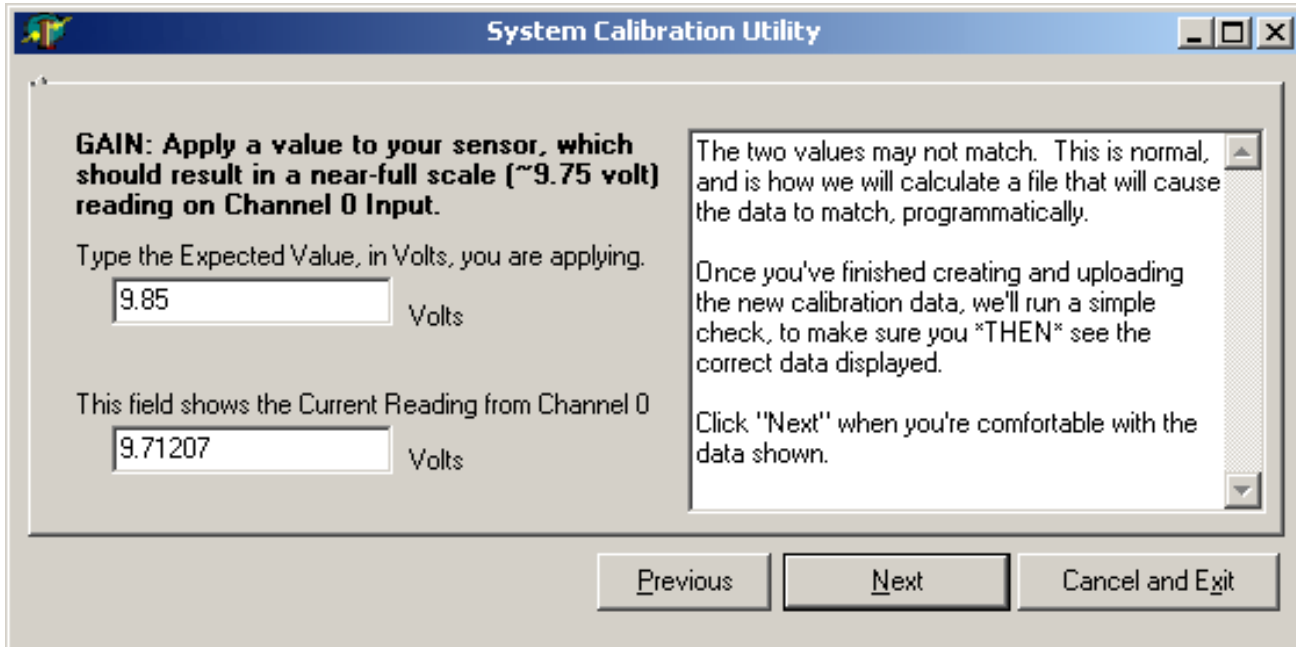

Figure 9-18: System Calibration Utility Screenshot 4 (gain)

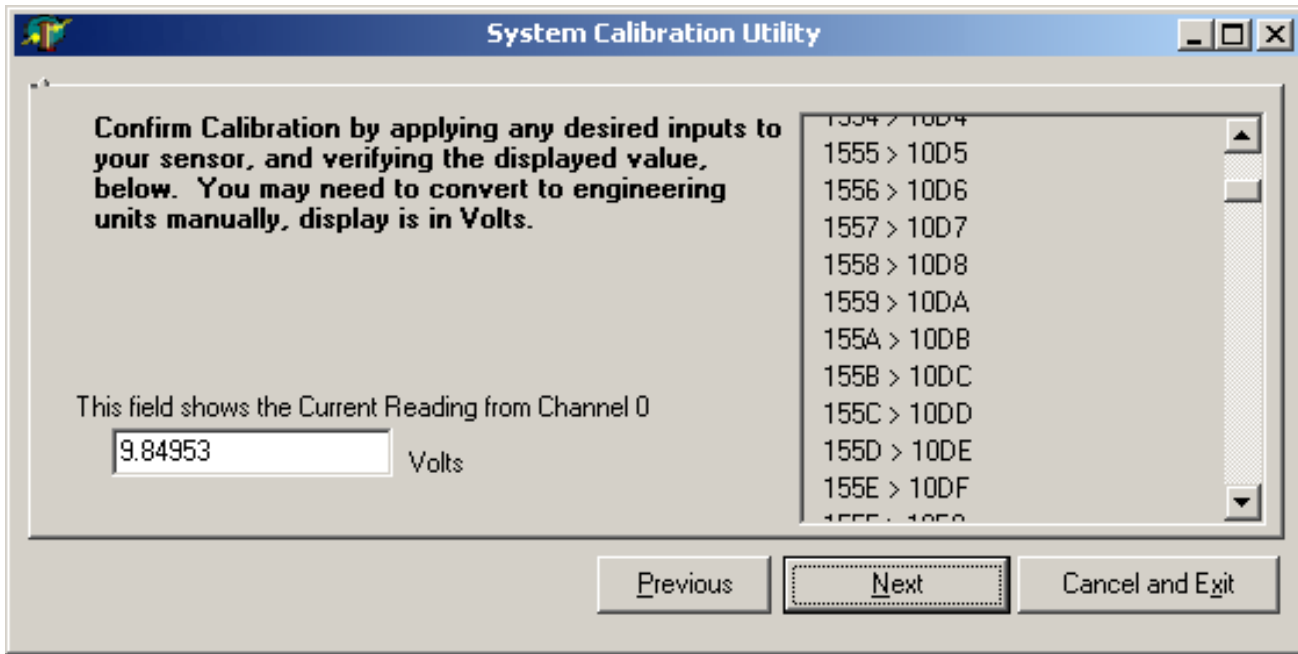

Figure 9-19: System Calibration Utility Screenshot 5 (confirmation)

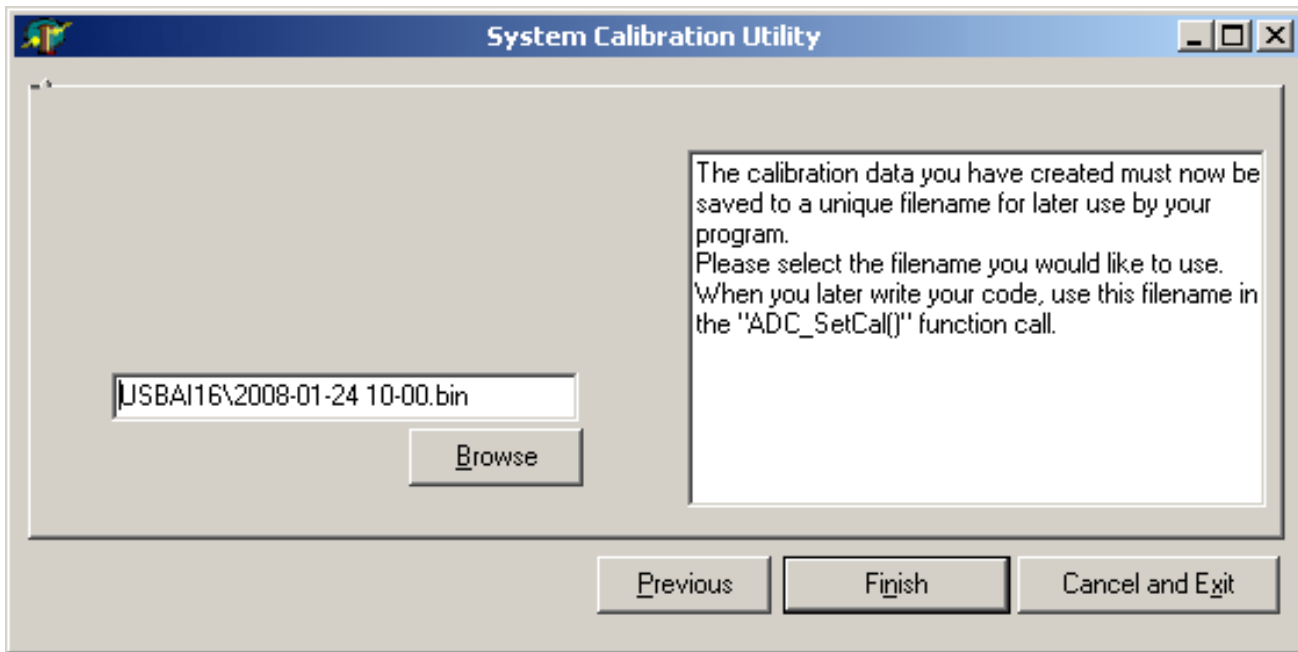

Figure 9-20: System Calibration Utility Screenshot 6 (finish and save)

Customer Comments

If you experience any problems with this manual or just want to give us some feedback, please email us at: ***manuals@acesio.com***. Please detail any errors you find and include your mailing address so that we can send you any manual updates.

