

# Installation Manual

## Wide Angle Models:

- AV2225PMIR
- AV2225PMIR-A
- AV2226PMIR
- AV3225PMIR
- AV3226PMIR
- AV3226PMIR-A
- AV5225PMIR
- AV5225PMIR-A
- AV10225PMIR

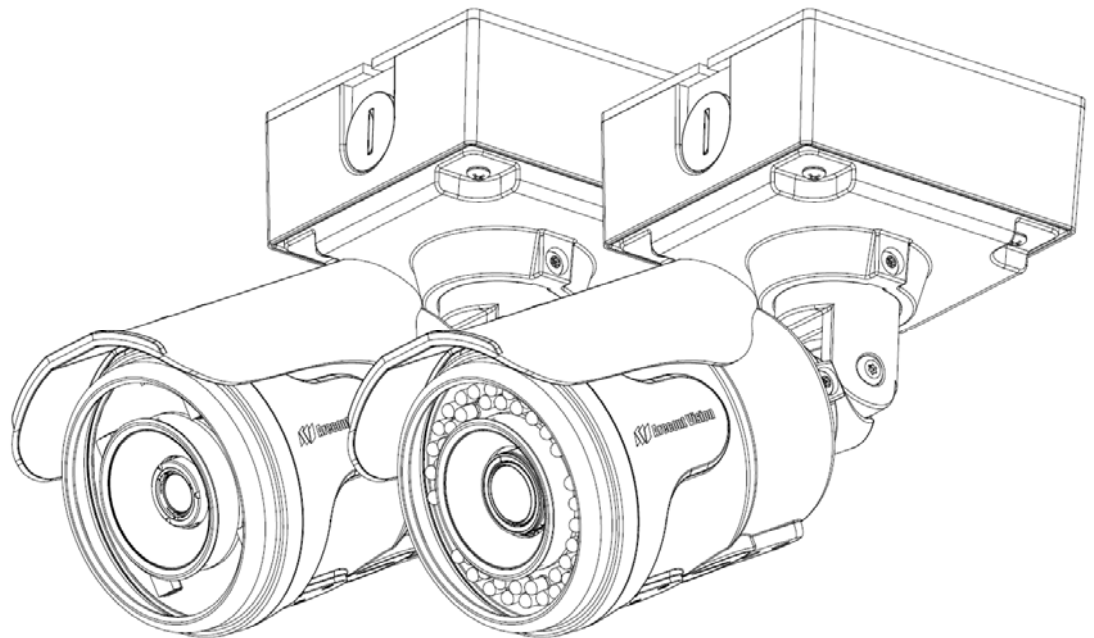

Telephoto Model

Wide Angle Models

## Telephoto Models:

- AV2225PMTIR
- AV2226PMTIR
- AV3225PMTIR
- AV3226PMTIR
- AV5225PMTIR
- AV10225PMTIR

## MegaView® 2 Installation

### Contents

Package Contents.....	3
Warranty Information .....	4
Install MegaView® 2 Camera.....	5
Replacing the IR LED board:.....	10
Camera Software Installation .....	11
Electrical Box Adapter (SV-EBA) Installation Instructions (Sold Separately) .....	13
Pole Mount Adapter (MD-PMA) Installation Instructions (Sold Separately).....	14
Corner Mount Adapter (MD-CRMA) Installation Instructions (Sold Separately) .....	15
LED Indicators (Camera Signal) .....	16
Support .....	17
Mounting Template .....	18

## Package Contents

### MegaView® 2 Camera Package:

- A. Arecont Vision MegaView® 2 Camera
- B. Junction box adapter
- C. Mounting Template for Junction box adapter
- D. Mounting Template for MegaView® 2 Camera
- E. CD with AV100 software and user manuals (license key required for recording)
- F. Security L-key
- G. Pack of four (4) screws and four (4) anchors
  - NOTE: Anchors and screws are good to be used for concrete, wall block and red bricks.*
  - NOTE: Screws by themselves can be used in wood.*
- H. Rubber plug
- I. Pack of four (4) machine screws, #8-32, ½" Phillips Pan Head



Image 1

## Warranty Information

### 3 Year Limited Warranty

ARECONT VISION warrants to Purchaser (and only Purchaser) (the “Limited Warranty”), that: (a) each Product shall be free from material defects in material and workmanship for a period of **thirty-six (36) months** from the date of shipment (the “Warranty Period”); (b) during the Warranty Period, the Products will materially conform with the specification in the applicable documentation; (c) all licensed programs accompanying the Product (the “Licensed Programs”) will materially conform with applicable specifications. Notwithstanding the preceding provisions, ARECONT VISION shall have no obligation or responsibility with respect to any Product that (i) has been modified or altered without ARECONT VISION’s written authorization; (ii) has not been used in accordance with applicable documentation; (iii) has been subjected to unusual stress, neglect, misuse, abuse, improper storage, testing or connection; or unauthorized repair; or (iv) is no longer covered under the Warranty Period. ARECONT VISION MAKE NO WARRANTIES OR CONDITIONS, EXPRESS, IMPLIED, STATUTORY OR OTHERWISE, OTHER THAN THE EXPRESS LIMITED WARRANTIES MADE BY ARECONT VISION ABOVE, AND ARECONT VISION HEREBY SPECIFICALLY DISCLAIMS ALL OTHER EXPRESS, STATUTORY AND IMPLIED WARRANTIES AND CONDITIONS, INCLUDING THE IMPLIED WARRANTIES OF MERCHANTABILITY, FITNESS FOR A PARTICULAR PURPOSE, NON-INFRINGEMENT AND THE IMPLIED CONDITION OF SATISFACTORY QUALITY. ALL LICENSED PROGRAMS ARE LICENSED ON AN “AS IS” BASIS WITHOUT WARRANTY. ARECONT VISION DOES NOT WARRANT THAT (I) THE OPERATION OF THE PRODUCTS OR PARTS WILL BE UNINTERRUPTED OR ERROR FREE; (II) THE PRODUCTS OR PARTS AND DOCUMENTATION WILL MEET THE END USERS’ REQUIREMENTS; (III) THE PRODUCTS OR PARTS WILL OPERATE IN COMBINATIONS AND CONFIGURATIONS SELECTED BY THE END USER; OTHER THAN COMBINATIONS AND CONFIGURATIONS WITH PARTS OR OTHER PRODUCTS AUTHORIZED BY ARECONT VISION OR (IV) THAT ALL LICENSED PROGRAM ERRORS WILL BE CORRECTED.

For RMA and Advance Replacement information visit [ArecontVision.com](http://ArecontVision.com)

### Install MegaView® 2 Camera

#### Mounting the Camera:

1. Remove camera and hardware from the box.
2. Use the mounting template (**Image 1-C**), to prepare the mounting provisions for junction box adapter installation.
3. Attach provided Junction Box Adapter (**Image 1-B**) to the wall using appropriate hardware.  
*NOTE: Hardware, provided with the unit, is only suitable for surfaces listed on page 3.*
4. Remove the conduit plug on Junction box adapter and connect 3/4" NPT conduit pipe to Junction Box Adapter shown in **Image 2**.

*NOTE: Use silicon or water pipe seal tape to make sure no water leakage between conduit pipe and junction box adapter.*

5. Run Ethernet cable and other cables (if necessary) through the Junction Box Adapter and connect to Megaview® 2 pigtail cable as shown in **Image 8**.
6. Add provided rubber plug (**Image 1-H**) on the bracket to ensure a water tight installation for outdoor applications as shown in **Image 3**.
7. Organize pigtail cable and attach MegaView® 2 camera to Junction Box Adapter using provided screws (**Image 1-I**) as shown in **Image 3-1** and **Image 4**.

*NOTE 1: Water damage from improper installation is not covered by the warranty!*

*NOTE 2: Use of silicon on the RJ45 connector without junction box adapter does not guarantee a water resistant install.*

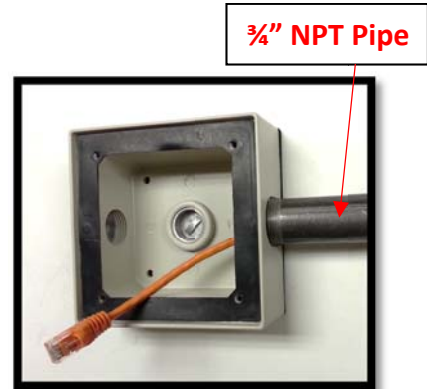

Image 2



Image 3



Image 3-1



Image 4

8. Use the security L-key to adjust MegaView® 2 bracket to appropriate position. ( Image 5)



Image 5

**CAUTION:** Only adjust the screws with an arrow pointing to them on the bracket base and camera body (Image 6)

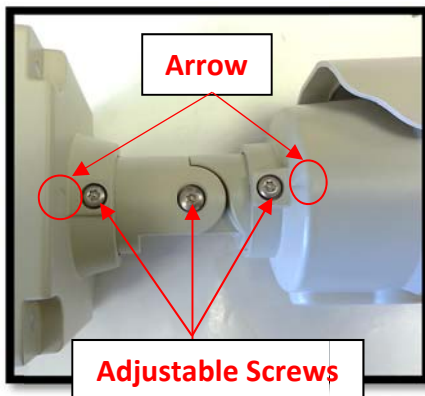

Image 6

**NOTE 1:** Bracket screws are all security screws that are tamper-resistant.

**NOTE 2:** Bracket with 3 axes enables easy installation in any location, including 360° camera body rotation, 90° tilt, 360° bracket rotation. (Image 7)

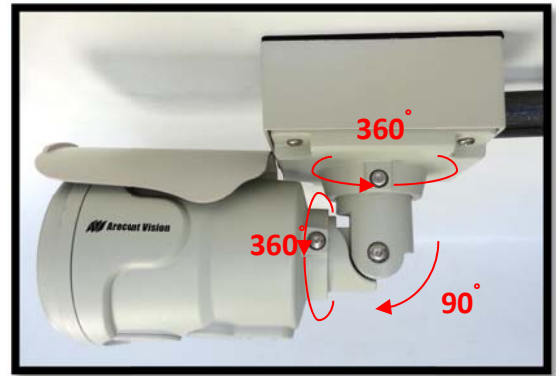

Image 7

**NOTE 3:** MegaView® 2 is a total PoE class 3 solution to power the camera, IR illuminator and fan. Fan is always on.

**NOTE 4:** To use the external power, 12-48VDC or 24VAC, power on camera, connect external power with pigtail cable connector (Image 8)

**NOTE 5:** Only MegaView® 2 –A audio models have female 3.5mm audio in / out jack.

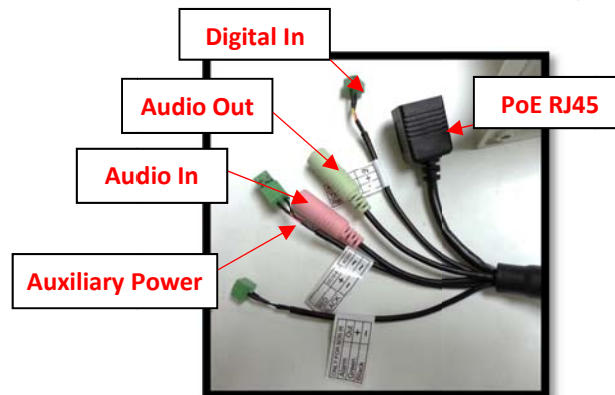

Image 8

**Optional: Connecting Digital I/O:**

- To use digital I/O, connect digital I/O with pigtail cable connector as shown in **Image 8**.

*NOTE 1: MegaView® 2 only supports digital input but no digital output.*

*NOTE 2: Table 1 shows electrical characteristics*

Electrical Characteristics:		Min	Max
Input voltage (V) (measured between + and - terminals)	ON	2.9	6.3
	OFF	0	1.3
	OFF	-	0.1

**Table 1**

*NOTE 3: The digital input is electrically isolated from the rest of the camera’s electrical circuitry via general-purpose photo couplers. The input is additionally protected with a serial 250 Ohm resistor, and a debouncing circuit. Duration of any input signal should be at least 5 ms to comply with the requirements of the debouncing circuit.*

*NOTE 4: Table 2 shows cable color for digital input*

Green	Digital IN +
Black	Digital IN -

**Table 2**

**Adjusting the Remote Focus and Remote Zoom:**

*NOTE: MegaView® 2 camera operating temperature is -40°C (-40 °F) to +50°C (122 °F), however, motorized lens operating temperature is -20°C (-4°F) to +50°C (122 °F).*

- To adjust focus or zoom, open the camera web interface and click the “Focus” tab as shown in **image 9**.
- To manually adjust zoom, click the “+20”, “+5”, “+1”, “-20”, “-5”, “-1” buttons to zoom in and out, adjusting the field of view.

*NOTE 1: “+20” zooms in 20x further than “+1”*

*NOTE 2: If the “Enable Auto Focus after zoom” option is checked as shown in image 8, the focus will automatically be adjusted when zoom is changed.*

- Set up a focus area (if necessary) by drawing a rectangle with the mouse (by left-clicking and dragging the mouse to a desired zoom size) shown in Image 8.
- To automatically adjust focus, choose “Full-range Focusing” or “Fast Focusing” depending on the image clarity as shown in image 8.
- If the image is completely out of focus, choose “Full-range Focusing” to scan the full focus range and find the best focus position.
- If the image is slightly of out of focus, choose “Short-rang Focusing” to fine tune and quickly get a precise focus position to save time.

16. To manually focus, click the “+20”, “+5”, “+1”, “-20”, “-5”, “-1” buttons to fine tune the focus.

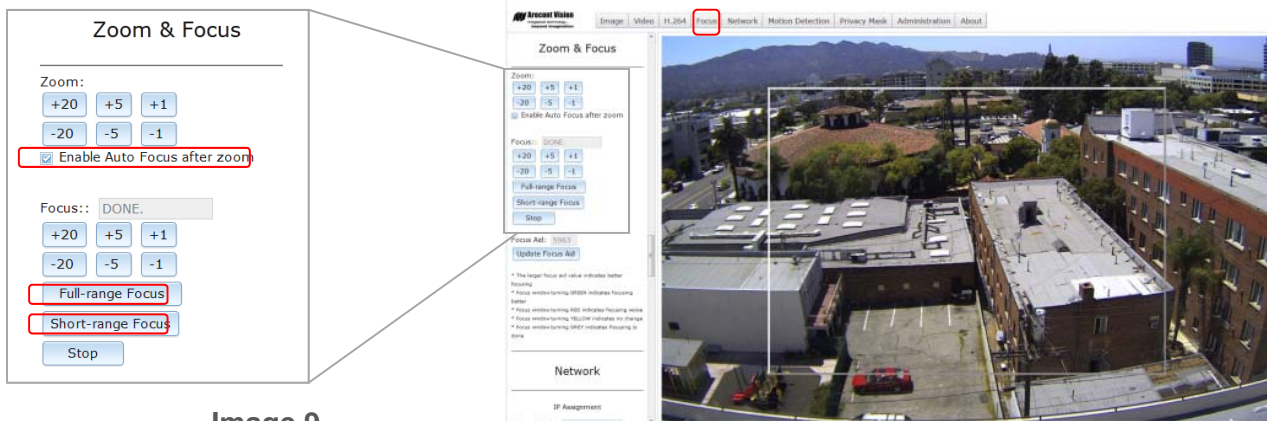

Image 9

### Adjusting P-Iris:

*Note: If “Enable P-Iris” is unchecked, the iris will be fully open to the maximum. It may result in less sharpness and artificial color under strong light condition.*

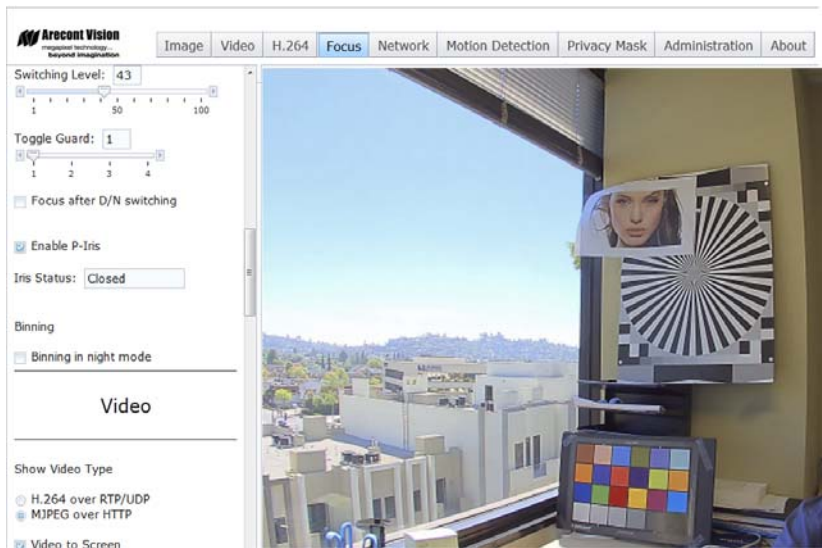

Image 9-1



**Optional: Enable Audio:**

17. Connect a mono analog microphone to Microphone In and connect an active speaker with a built-in amplifier via the in-line jack as shown in Image 8, if needed.
  
18. Choose “H.264 over RTP/UDP” as shown on Image 10-1 and check “Enable Microphone” then click “Preview” and “Apply” buttons as shown on Image 10-2.  
*NOTE: Audio only works in H.264 RTP/UDP streaming*

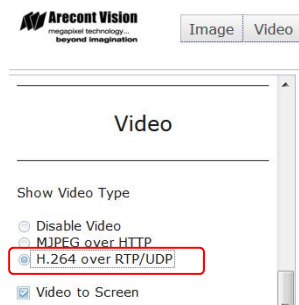

Image 10-1

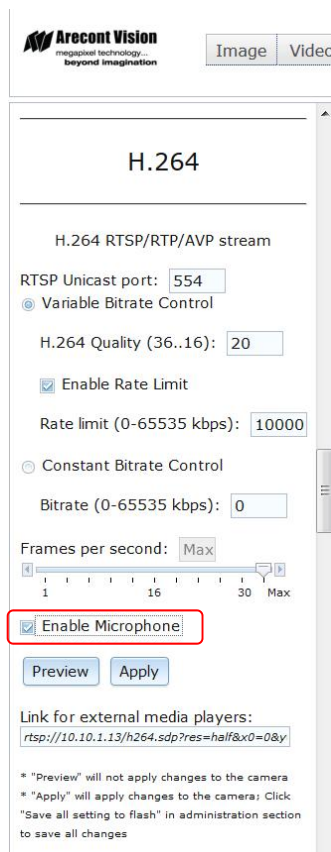

Image 10-2

### Replacing the IR LED board:

19. Unscrew glass ring (Image 11)
20. Use Phillips screwdriver to remove IR LED board (Image 12)
21. To replace IR LED board, unplug cable and replace new IR LED board (Image 12-1)

*NOTE: IR LED board part number: M000094-34*



Image 12



Image 11

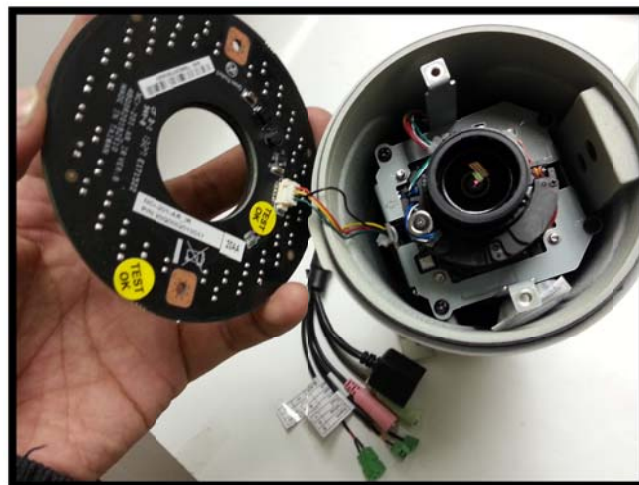

Image 12-1

## Camera Software Installation

22. Install the AV100 application manager Software. (Image 13, found on the CD).
23. Run the AV100 application manager by double clicking on the icon shown below. (Image 14, found on your desktop).

NOTE: you can download latest version AV100 on website

<http://www.arecontvision.com/software.php>

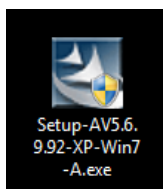

Image 13

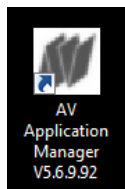

Image 14

24. Select “Run” next to “Setup Cameras” from the AV100 application manager as shown in Image 15 and wait for “Arecont Vision Camera Installer” window to appear as shown in Image 16.



Image 15

25. Click “Mode” tab to select desired install mode on the Arecont Vision Camera Installer as shown in Image 16.

NOTE 1: Advanced Mode: (Default setting) software will automatically discover but allow manual update of the IP address. See “AV100 Installation Manual” (found on the CD) for details on Advanced Mode.

NOTE 2: Basic Mode: software will automatically discover and change / assign IP address to match PC subnet if they are not locked.

NOTE3: User can verify camera model number and FW version of all cameras as shown in Image 16.

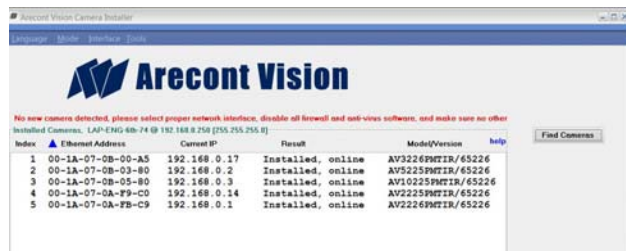

Image 16

26. select “Find Cameras” on the Arecont Vision Camera Installer as shown in Image 16.

27. Confirm that all the cameras connected to the network switch appear in the upper window.
28. Repeat Step 24 if all of the cameras do not appear in the upper window.

*CAUTION: If the software does not find a camera, the software utility may be blocked by the anti-virus or Windows® firewall. Before turning them off, please consult your IT manager.*

*NOTE : Double click the camera model on the Camera Installer as shown in Image 17 to access the camera web interface. See “AV Camera Web Page User Manual” (found on the CD) for details on the web interface.*



Image 17

29. When all cameras are discovered and display “Installed, online”, select “Save/Exit.” The AV100 application main menu will appear.
30. From the “AV100 Application Manager” menu, select “Run” next to “Live video” to view live images.

*NOTE: See the “AV100 Installation Manual” (found on CD) for details on camera configurations.*

## Electrical Box Adapter (SV-EBA) Installation Instructions (Sold Separately)

### Inside the box:

- A. Electrical Box Adapter
- B. Pack of four (4) machine screws (#8-32 7/16")

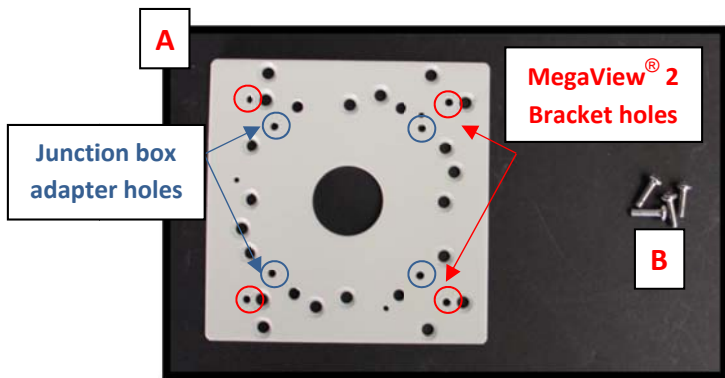

Image 18

### Not included but needed:

- Common electrical box, such as single gang box, double gang box, or square electrical boxes shown in **Image 18-1~4**.
1. Remove the electrical box adapter and hardware from the box.
  2. Attach the wall mount bracket to the electrical box adapter.
  3. Attach adapter to electrical box.

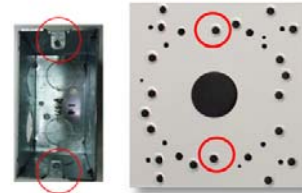

Image 18-1 Single gang box



Image 18-2 Double gang box



Image 18-3 Square box

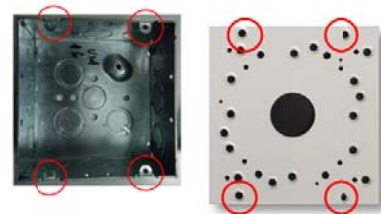

Image 18-4 Square box

# Pole Mount Adapter (MD-PMA) Installation Instructions (Sold Separately)

**Inside the box:**

- A. Pole Mount Adapter
- B. 2x Compression Fittings
- C. 2x Small Steel Straps
- D. 2x Large Steel Straps
- E. Pack of four (4) machine screws (#8-32 5/8")

**Not included but needed:**

- SV-EBA (Electrical box adapter)

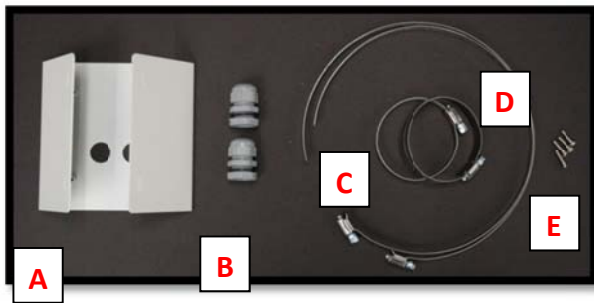

**Image 19**

1. Remove Pole Mount Adapter, steel Straps and hardware from the box.
2. Attach SV-EBA to Pole Mount Adapter as shown in **Image 20**.
3. Attach provided Junction Box Adapter (**Image 1-B**) to SV-EBA.
4. Remove the conduit plug on Junction box adapter and connect 3/4" NPT Conduit to Junction Box Adapter shown in **Image 20-1**.

*NOTE: Use silicon or water pipe seal tape to make sure no water leakage between conduit pipe and junction box adapter.*

5. Run Ethernet Cable and other cables (if necessary) through the Junction Box Adapter and connect to MegaView® 2 pigtail cable.
6. Attach MegaView® 2 bracket to Pole Mount Adapter as shown in **Image 21**.
7. Use the supplied two Steel Straps to attach the Pole Mount Adapter to the pole and tighten the compression screws as shown in **Image 21**.
8. To adjust MegaView® 2 bracket, please reference "Mounting the Camera", if needed.



**Image 20**

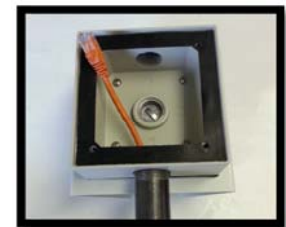

**Image 20-1**



**Image 21**

## Corner Mount Adapter (MD-CRMA) Installation Instructions (Sold Separately)

### Inside the box:

- A. Corner Mount Adapter
- B. 2x Compression Fittings
- C. Pack of four (4) machine screws (#8-32 5/8")
- D. 2x Packs of four (4) screws and four (4) anchors

### Not included but needed:

- SV-EBA (Electrical box adapter)

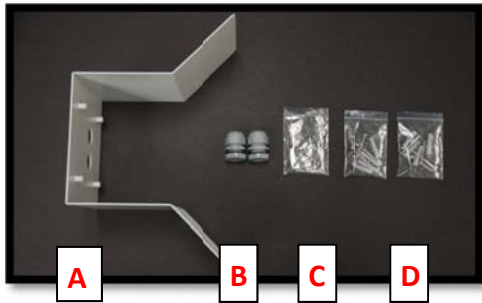

Image 22

1. Remove Corner Mount Adapter and hardware from the box.
2. Attach SV-EBA to Corner Mount Adapter as shown in **Image 23**.
3. Attach provided Junction Box Adapter (**Image 1-B**) to SV-EBA.
4. Remove the conduit plug on Junction box adapter and connect 3/4" NPT Conduit to Junction Box Adapter shown in **Image 23-1**.

*NOTE: Use silicon or water pipe seal tape to make sure no water leakage between conduit pipe and junction box adapter.*

5. Run Ethernet Cable and other cables (if necessary) through the Junction Box Adapter and connect to Megaview® 2 pigtail cable.
6. Attach MegaView® 2 bracket to Corner Mount Adapter as shown in **Image 24**.
7. Using the screws provided (or other hardware) to attach the Corner Mount Adapter to an exterior 90° corner wall as shown in **Image 24**.
8. To adjust MegaView® 2 bracket, please reference "Mounting the Camera", if needed.

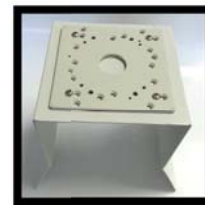

Image 23



Image 23-1



Image 24

## LED Indicators (Camera Signal)

*NOTE: To see the LED indicators, open the plug on the camera body as shown in **Image 25**.*

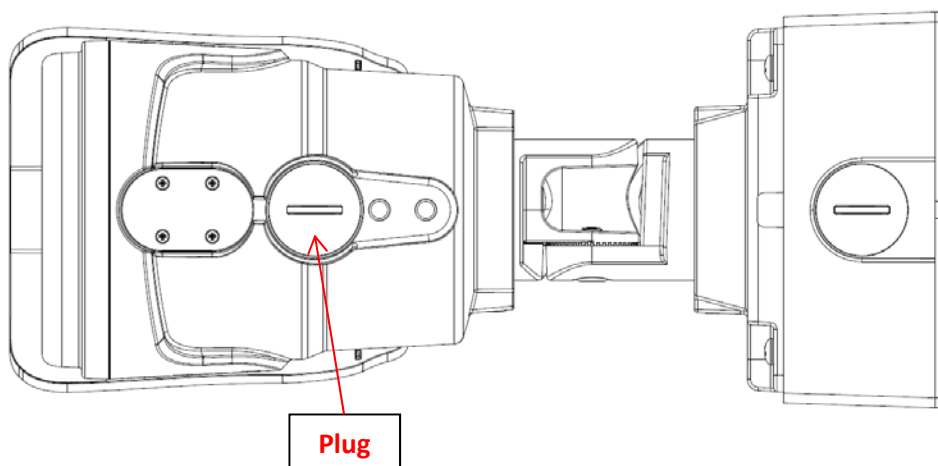

Image 25

LED	Status	Description
Yellow	Flashing	Link has been established.
	Solid	Normal Operation.
	None	No connection.
Green	Flashing	Camera has been accessed. Normal operation.
	Solid	N/A
	None	No Connection.



## Support

1. Arecont Vision FAQ Page Located at [ArecontVision.com](http://ArecontVision.com)
2. Check the following before you call:
  - ✓ Restore camera to factory default with AV100, AV200 or the camera webpage.
  - ✓ Upgrade to the latest firmware by visiting [ArecontVision.com](http://ArecontVision.com).
  - ✓ Isolate the camera on a dedicated network and test with AV100 or AV200.
  - ✓ Swap the “troubled” camera with a known good camera to see if the problem follows the camera or stays at the location.
3. Contact Arecont Vision Technical Support one of three ways:
  - 1. Online Portal : [Support.ArecontVision.com](http://Support.ArecontVision.com)**
  - 2. Phone : 1.818.937.0700 (option #1)**
  - 3. Email : [support@arecontvision.com](mailto:support@arecontvision.com)**

## Mounting Template

### Junction Box Adapter Mounting Template

