



SE-800

datavideo®

PRODUCT GUIDE

DV Format Converters, Video Switchers
Long DV Cables & Repeaters,
DVD Recorders, Chroma keys,
Video Standards Converter, TBC's.



© 2006 Datavideo Corporation. All Rights Reserved.



▶ SE-800 DV

▶ SE-800 AV

Unit Dimensions/Weight

Width:	17 inches, 430 mm
Depth:	16.8 inches, 420 mm
Height:	4.72 inches, 120 mm
Net Weight:	14 lbs, 6.4 kgs

Producers can now shoot, mix, and edit their video all within the DV25 format while controlling the SE-800's dissolve, chroma key, and more than 50 built in effects with its full size keypad, control panel, or remotely via PC.

▶ SE-800 DV



Video Inputs
DV (DV25), Component, Y/C (S-Video), or Composite Video.



Video Outputs
DV (DV25), Component, Y/C (S-Video), Composite and SDI.



SDI Character Generator
Use Datavideo CG-100, SDI Character Generator.

▶ SE-800 AV



Video Inputs
Component, Y/C (S-Video), or Composite Video.



Video Outputs
Component, Y/C (S-Video), Composite Video.

SE-800DV Rear View

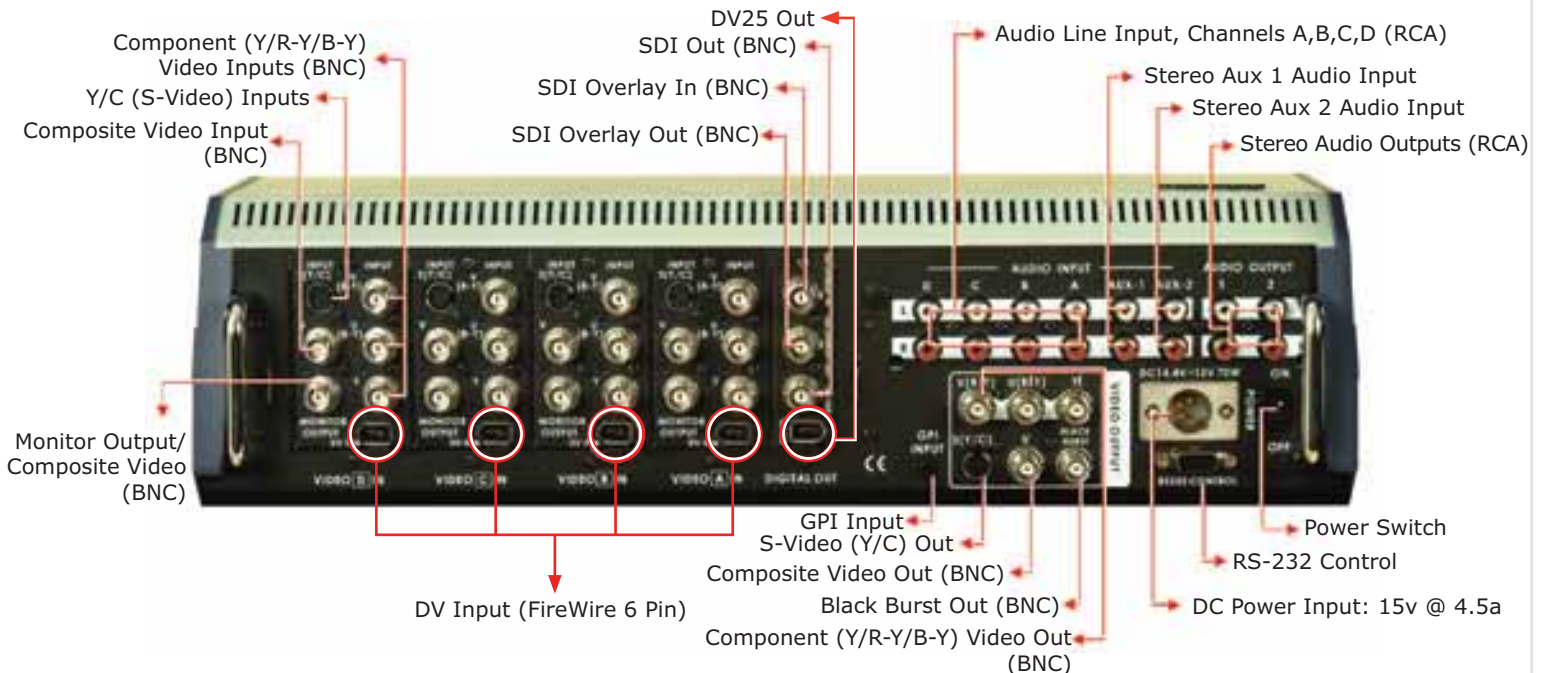

SE-800DV Included Accessories

CA64 (2), 2266 6/6P, 1.8M (2), 2264 6/4P, 1.8M (2)
 GPI Cable (1), Case, Power Cord, Power Supply 110/220

SE-800AV Included Accessories

Y/C (S-Video) 4ft/1.22m (2), GPI Cable (1), Case, Power Cord,
 Power Supply 110/220

Common Features for SE-800 DV and SE-800 AV

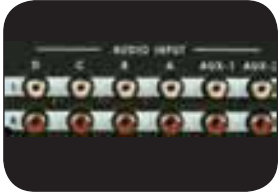

Audio Inputs
 4 Stereo pairs and 2 Aux
 - Unbalanced audio.



Audio Outputs
 2 main and 1 earphone
 with volume control.



Voice Sync.
 Advance or delay the
 audio to match the video.



Joystick
 Control RGB or PIP.



Color Processor
 Includes RGB adjustment
 for white balance. Stores
 last setup.



6 Channel Stereo Mixer
 Unbalanced in/out.
 Use BAC-03 accessory
 for balanced audio.



50+ Digital Effects
 Dissolve, Cut, Chroma
 Key, Mosaic, PIP, Strobe,
 Wipe, ect.



Programmable Playback
 Save 30 transitions.
 Playback by pressing a
 single key.



RS-232 Control Protocol
 Available on website.



GPI Input
 Controls preprogrammed
 EFX F01 to F30 in sequence.



Network PC Control
 See website for details.
www.datavideo.us



No Genlock
 Dual channel TBC and
 4:2:2 frame synchronizer
 built-in.



SE-800 Carrying Case
 (Included)

FREE TRIAL

CALL US (562) 696-2324
 OR
 E-MAIL: contactus@datavideo.us

SE-800AV Rear View



SE-800 Accessories

Converting PowerPoint® files to high quality video is no longer a time consuming necessity.

PPT-100

PowerPoint to DV25 Software. Use this PC program to convert PowerPoint or other programs, to DV25 for editing or as a switcher source. (P/N PPT-100)

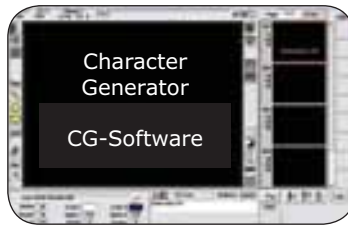

CG-100

This software combined with a DeckLink card and a PC is a high quality, easy to use CG. (P/N CG-100)



MP-6000 DVD RW+Recorder

Burn DVD directly from the SE-800. This recorder accepts a DV25 input. (P/N MP-6000)



DV25 Hard Drive Recorder

Burn, Record up to 9 hours of DV25 for archiving or future storage. (P/N DN-100)



TLM-70 LCD Monitor

7" portable LCD monitor with DV25 and Composite Inputs. Includes speakers. (P/N TLM-70)



RMC-140

Next Source - Tally - Quad Split, POP or PIP Preview accessory. Includes tally lights that mount on your camera.



BAC-03

A powered, bi-directional audio balanced/unbalanced converter using active transformers for best audio response.

SE-800 DV (with FireWire)

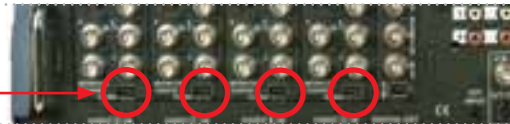

SE-800 AV (without FireWire)



RKM-4N7

Specifications SE-800DV & AV

TWO MODELS	SE-800DV	SE-800AV
VIDEO INPUTS		
DV25 INPUTS (VIDEO & AUDIO)	4	0
COMPOSITE INPUT	4	4
Y/C (S-VIDEO) INPUT	4	4
COMPONENT INPUT	4	4
AUDIO INPUTS		
STEREO ANALOG FOR VIDEO (UNBALANCED)	4	4
STEREO (AUX)	2	2
VIDEO OUTPUTS		
DV25	1	0
SDI	1	0
COMPOSITE	1	1
Y/C (S-VIDEO)	1	1
COMPONENT	1	1
AUDIO OUTPUTS		
STEREO ANALOG (UNBALANCED)	2	2
EARPHONE	1	1
VIDEO MONITOR OUTPUTS COMPOSITE	4	4

(NTSC and PAL B are separate models)

Color Processing

Brightness +/- 20%,
Contrast +/- 3 dB,
Color +/- 10 dB

Signal/Noise Ratio

Video > 55 dB, Audio > 65 dB

CG, DP

+/- 3%, 3 degree

Audio

THD < 1%

GPI Control

Remote trigger controls preprogrammed effects from F01 to F30 in sequence

Remote Control

RS-232, free PC interface available on website www.datavideo.us

Power

Input: AC 90V to 240V auto sensing
Output: DC 15V/50W

Dimensions/Weight SE-800

17" x 16.8" x 4.72", 430mm x 420mm x 120mm, 14 lbs/6.4 kgs

SE-800 with TLM-404 and Holder

17" x 18" x 9", 430mm x 457mm x 229mm, 21 lbs/6.4 kgs

Q: Can it accept four DV25 sources?

A: The SE-800DV does. The SE-800AV may be upgraded.

Q: Does it also accept four of any other format?

A: Yes. Both the SE-800 and the SE-800AV accept Component, Composite, and Y/C (S-Video).

Q: Do we need TBC's or Frame Synch's?

A: No

Q: Is there a problem with audio/video synch in DV?

A: No problem. You do have to set it. The instruction book and web site explain how.

Q: Is there a video delay?

A: Yes there is a DV25 delay. This means that if you are doing I-MAG or projecting a video image of the speaker, their video actions will be about five frames or 1/6th of a second later than their real movements. This is noticeable. There is less of a delay with Y/C (S-Video) cameras.

Q: How do you use an external audio mixer?

A: To use sound from an external audio mixer, you must connect the mixer to the A, B, C or D source audio input channels on the SE-800. You will then need to disable the DV25 audio stream from the SE-800. Do not use the AUX input for audio that you want to synchronize to video.

Using an external audio mixer

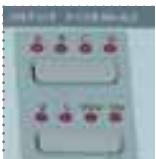

Separate the DV25 audio from the DV25 video so you can use an external audio mixer. Connect the mixer input to channel A, B, C, or D but not to aux inputs.

1. Press the INPUT FORMAT button. To select channel A, B, C or D



2. Press the "SPD" key to toggle "N" and "Y". "Y" enables the DV25 audio on each DV25 input. "N" disables the DV25 audio on the DV25 input and enables the analog line inputs.

3. Press the INPUT FORMAT button to exit and save your current selection. Note: Connect the output from your mixing board to channels A, B, C, D only, or your audio and video will not be in SYNC. Do not connect it to the AUX input on the mixer.

Q: What is the advantage of the Datavideo TLM-404 - 4 LCD display over the others?

A: (1) Combined with the custom holder, the

Q: What is the advantage of the Datavideo TLM-404 - 4 LCD display over the others?

A: (1) Combined with the custom holder, the Datavideo display is less expensive than others and uses LCD panels with similar specifications.

(2) The controls on the Datavideo TLM-404 are "recessed" to prevent being broken off.

(3) The TLM-404 has on/off switches on the front. With the custom holder, the monitors can be seen while operating the controls of the SE-800. This is particularly important to users who are not operating this equipment every day.

Q: Long DV cables?

A: Datavideo guarantees the performance of our cables when used with our DV25 repeaters, to carry a DV25 video signal. In other words, you can use these cables and repeaters to put your DV25 source 20, 40, 60 meters or more away from the switcher.

Q: What is the warranty?

A: One-year parts and labor. Extenuating circumstances are always considered.

Q: Does the SE-800 have a Demo mode?

A: Yes. Press and hold the PLAY button to activate it.

Q: What about HDV and 16:9 cameras?

A: These cameras also output (normal) DV25. The SE-800 will work with DV25.

Q: Can we use the carrying case as a shipping case?

A: No, please do not.

Q: Do you charge for firmware updates?

A: No charge for firmware updates.

Q: How do I set up the audio on the SE-800 so it does not change when selecting different video sources?

A: * When the A/V button is not enabled the audio source does not change when video channels are changed.

* When a single audio input from a sound board is used as an audio source, fade in/out of video would not affect the audio. In other words, the audio would stay active and not fade.

* When you turn on the A/V button and fade from "A" (Audio is present) to a channel that does not have audio, you will get a slow fade in the audio. It does not matter if you fade to a color or fade to video, the audio will fade out.

Q: What are the sizes of the picture in Picture Windows?

A: The Small PIP Window has a Width of 185 pixels and a Height of 147 pixels. The Large PIP Window has a Width of 284 pixels and a Height of 207 pixels.

Q What about RS-232 control via Crestron or AMX?

A The RS-232 protocol is on the web site. We will work with you.

Q Do we need Genlock?

A No, you do not.

Q What are the frame rates of the SE-800 dissolve speeds?

A Speed 1 = 84 Fr
Speed 2 = 45 Fr
Speed 3 = 32 Fr
Speed 4 = 26 Fr
Speed 5 = 18 Fr
Speed 6 = 11 Fr
Speed 7 = 6 Fr
Speed 8 = 5 Fr
Speed 9 = 4 Fr

Multi camera shoots in the field require that you make a tape and probably a disk back up so that upon return to the studio you can transfer files or digitize all of your footage.

The process goes faster and your story can have more integrity, if while you are shooting, a program cut is made on site.

In this example, SITV the production company and Marcos Cline the director were making a cable series about the opinions of young, English speaking Hispanics.

The production took place in two different parts of a restaurant. The SE-800 was mounted on a cart that rolled between locations.



DV cameras were connected to the SE-800 using 20 meter cables and DV Repeaters. The camera operators used headsets to communicate with the director who was at the SE-800.



The action at this table was seen by three cameras and edited live. Time was saved because the emotions of the moment were enhanced by being able to see and control the camera transitions in real time.



The TLM-70 monitor was used to view program from the SE-800 so the director, makeup and continuity people could check everything.

Live production for specific cable channels (sports, cooking, etc) is a growing market but one with limited budgets. Since DV is the ideal production medium for this market, our SE-800DV is a perfect fit.

Easy to transport, the SE-800 and a four camera production shoot can be set up in just a few hours.

Royster Productions (Los Angeles) used the SE-800 to record the National Outdoor Raquetball Championship matches.

The SE-800 was located outside under a tent. Datavideo's long DV25 cables were used to connect the cameras to the switcher.

Royster Productions took advantage of Datavideo's demo program and tried the SE-800 on a job. They immediately purchased the SE-800, monitor and holder, cables and repeaters.

Almost every Datavideo product is available for a two week evaluation. Please contact your local reseller to arrange this.



The TLM-404 display with the SE-800 is bright enough so you can see it outdoors in a protected area. This allows the director to see each of the camera outputs, speak with the shooters and assemble the story as it happens.



Before the matches begin, the director reviews with each shooter what is expected and how he will be making production decisions.



The result is a live cablecast delivered on time and within budget.

SE-800 What to Order

This is a list of many of the things needed to set up a small studio. We offer it as a specific list of Datavideo products and a starting point in general.

PRODUCT	MSRP	
CAMERAS		
SE-800 DV - This model accepts four DV or analog video inputs and it includes the SDI overlay card. It also includes DV, SDI and analog outputs. Carrying case included.	US\$ 4,600	
SE-800 AV - This model accepts four analog video inputs. It does not have the SDI overlay card, the DV input cards or the DV and SDI output cards. The AV model is upgradable. Carrying case included.	US\$ 2,600	
SE-800AV Upgrade - SDI Overlay Card to use with the CG-100.	US\$ 989	
SE-800AV Upgrade - DV Input Card.	US\$ 289	
SE-800AV Upgrade - DV Output Card.	US\$ 549	
RKM-4N7 - Monitor Holder (included with the purchase of the TLM-404).	(incl)	
TLM-404 - 4 x 4" LCD display will show you each of the inputs to the SE-800. and RKM-4N7 - This holder accommodates the TLM-404. It has included "bolt on" ears that will hold the TLM-702.	US\$ 1,550	
TLM-702 - 2 x 7" LCD display used with the RMC-140 this dual 7" LCD display will show you the "next" source as well as the program out.	US\$ 850	
RMC-140 NextSource & Tally Accessory - Accepts a looped video output from the TLM-404 and RS-232 from the SE-800 to select the next source video and to illuminate up to four included LED tally lights which attach via velcro.	US\$ 499	
TDXT25 Tally Light Extention Cable 25 ft.	US\$ 25	
CA22644/6 DV cable	US\$ 12	
CA2066 - 20 meter DV Cable 6 pin.	US\$ 75	
VP-314 DV Repeater , self powered. This repeater operates on the 12VDC that is available when connected to the SE-800. Note: Each SE-800DV comes with four adapters that will allow you to connect a 6 pin DV cable to a 4 pin camera.	US\$ 60	
Analog Video Cables - Be sure to budget for these cables or DV cables.		
CG-100 Character Generator Software & DeckLink Card - The CG-100 works with a Blackmagic DeckLink card installed in a PC. The DeckLink card is a downstream keyer (DSK) that takes SDI out from the SE-800, keys text and graphics over it and then sends it back to the SE-800. The website includes a free demo version. Both the website and the product guide page specify minimum requirements for the computer.	US\$ 1,149	
PC - For the CG-100 - Don't forget this item - see CG-100 page for minimum requirements.		
ITC-1 - Intercom This 8 channel cable connected intercom will let one central person contact each or all of up to 8 others. Basic kit includes all that you need for four users and home base. See web/product guide page for details.	US\$ 999	
PD-1 - Power Distributor No more wall warts . PD-1 powers everything around and including the SE-800. See web/product guide page for details.	US\$ 699	
External Audio Microphone Mixer - estimated price.	US\$ 600	
DN-100 DV Bank Recorder - We are making a new model of this one and I want you to have that - we'll have to work out something fair to both of us.	US\$ 1,100	
DVK-100 Chromakey - See web/product guide page for details.	US\$ 1,200	
Background - See web/product guide page for suggestions.		
Production / Shipping Cases - See web/product guide page for details.		
MP-6000 Direct to DVD burner	US\$ 1,299	

Datavideo U.S.A.

12300 East Washington Blvd., Suite U, Whittier, CA 90606
 Tel: (562) 696-2324 Fax: (562) 698-6930
<http://www.datavideo.us>



Unit Dimensions/Weight

Width: 5.5 inches, 209.55 mm
Depth: 4.4 inches, 209.55 mm
Height: 1.6 inches, 88.9 mm
Net Weight: 2 lbs, 2.8 kgs

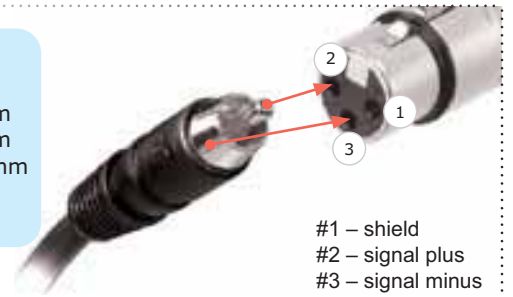

#1 – shield
 #2 – signal plus
 #3 – signal minus

BAC-03

Balanced Audio Converter

The BAC-03 is a powered, bi-directional audio level converter. For use with the SE-800 and in other applications, the BAC-03 will convert between balanced and unbalanced audio.

Viewed from Solder Side of Plug / Socket

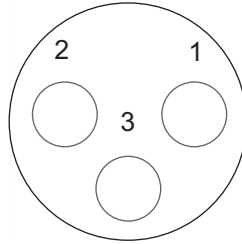

Plug

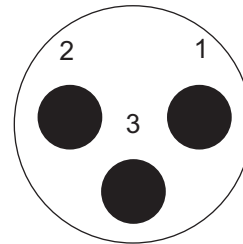

Socket

Included Accessories

BAC-03 Audio Converter Unit
 AC Adaptor DC 12 V 500MA
 Two 5 ft unbalanced audio cable
 (Red & White)

Front View



Rear View



Unit Dimensions/Weight

Width: 6.3 inches, 160 mm
Depth: 3.93 inches, 100 mm
Height: 1.95 inches, 49.5 mm
Net Weight: 5.36 lbs, 2.5 kgs



Tally Light

RMC-140

Preview / Tally

A next source and preview accessory for the SE-800 switchers. The RMC-140 will display your choice of Next Source, Quad Split with colored indicators, PIP or POP.

The included Tally Lights are connected and powered by mini phono plugs or via the Tally Out DB15 connector.



RMC-140 Rear View

RMC-140 Front View



Power connector (DV12V)



4 Composite Inputs



Display mode selects (Quad, POP, PIP and Next)



Tally Light output



Monitor output



Full screen next source preview output, Effect and Tally Light indicators



RS-232 input from SE-800



RS-232 Bypass

Included Accessories

RMC-140,
 RS232 cable x 1
 BNC 1.2m cable * 5,
 AC/DC Power Adapter DC 12V 1.5 AMP

▶ CG-100

Character Generator



PC Minimum Requirements

- CPU P4 3.0Ghz or above
- Memory 512MB or above
- Screen Display 1024x768/32 bits colors
- OS Windows XP-SP2
- DirectX 9.0c
- DeckLink Card (for NTSC/PAL B system)

Datavideo's CG-100 software is an affordable CG for the PC with excellent SDI quality. Based on the Blackmagic DeckLink card, it connects to the SDI Overlay/Graphics input on the SE-800 or any video switcher that accepts SDI keyed graphics input.

Operation

With this CG software you compose pages before they are used. For example, "lower thirds" or titles. And you can compose files "off line".

The CG-100 can hold many pages, limited only by the computer's processor speed and RAM speed and size. If you have 150-200 pages you will need a faster computer with more storage than if you have 50 pages. Text positioning may be done by mouse/eye or by X/Y pixel designation.

Package includes

CG-100 PC software. (Blackmagic card optional)

CG for use with other switchers

The CG-100 will work with any switcher that accepts the SDI video and key signal coming from the DeckLink card.

Driver notes

The CG-100 software requires use of the drivers included with the software.

System Diagram

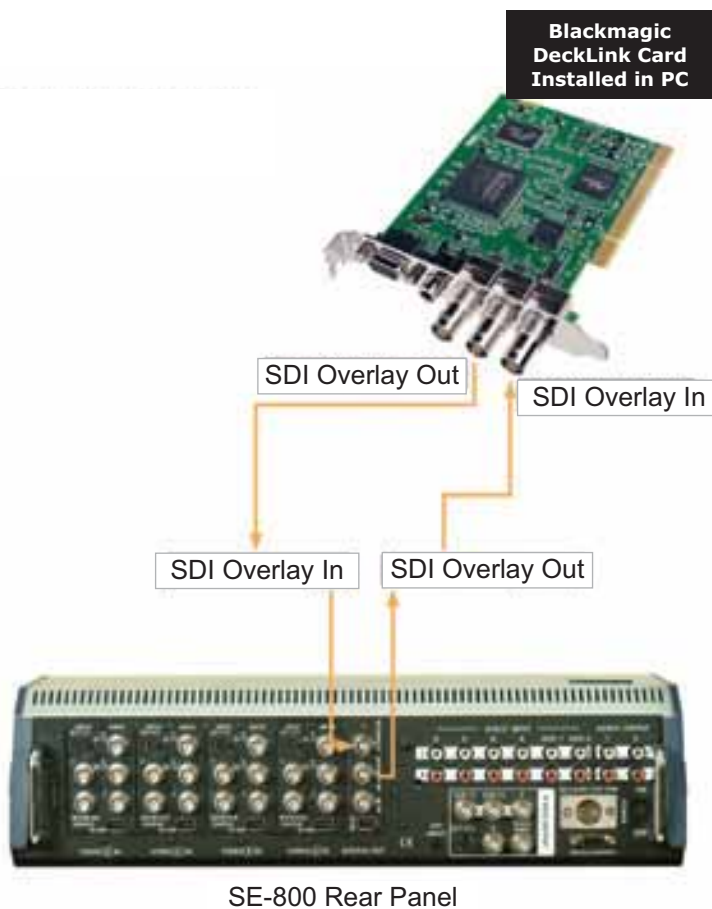

Font Selection

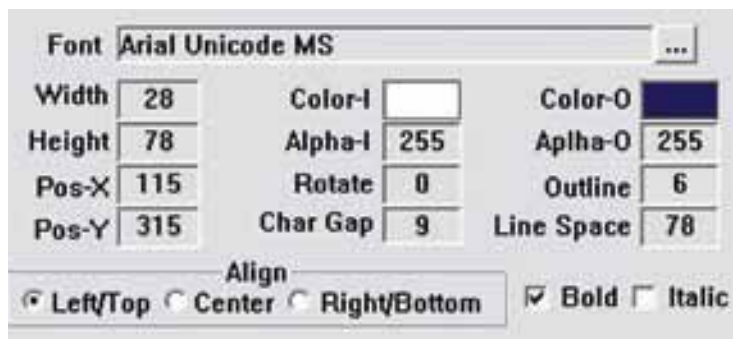

Trial software on website www.datavideo.us



1. Transfer text to CG function

- a. Generates subtitle from text files



2. Number Tags for text objects

- a. Number tag for each string helps verify sequence of text samples in sample page

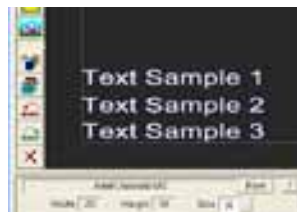

3. Mouse wheel to scroll CG pages

- a. Perfect to display subtitles



4. Targa sequence

- a. Export 3D animations or motion pictures as a sequence of targa files
- b. Prepare Targa sequence
- c. Adjust size and position of Targa sequence on screen
- d. Set Targa sequence as background
- e. Clear Targa sequence
- f. Add Targa sequence

5. Clock

- a. Insert a clock object on screen
- b. Selectable time format
- c. Adjust clock layout, text size, color and position



6. Timer / Stop Watch

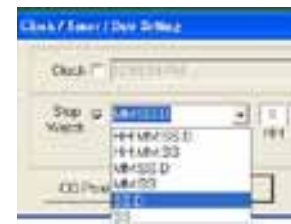

7. Logo Generator

- a. a special plug-in application
- b. Five independent layers of titles and graphics.
- c. One CG sample page to allocate the positions and colors of Targa sequence, logo, Roll/Crawl strings
- d. Twenty three CG backgrounds for Logos, Titles or other Graphics
- e. One upper layer of animated Targa sequence.
- f. One upper layer of a still Targa graphic for TV Channel's logo
- g. Two top layers of Roll/Crawl objects for emergency messages

8. System Buttons

- a. Zoom before play
- b. Clean
- c. Settings
- d. On line help
- e. Switch between Logo Generator and CG-100 layout editing mode

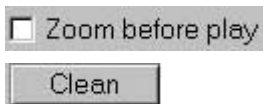

9. Logo Pages

- a. See the first 24 pages as icons after a VCG file is opened



10. Setup Templates

- a. TV Channel's logo
- b. Still Targa or Targa sequences

11. Add Crawl

- a. Two horizontal and two vertical crawls

12. Add a TV Channel's logo

13. Add background CG-100 pages

- a. Set additional background CG pages
- b. Add banner's background, images, wordings etc
- c. Set different "animation boxes" to create a background page

14. Commercial break

15. Quick LOGO Modification

- a. Directly edit the parameters of all Logo page icons

16. GPI Trigger

- a. Set GPI to trigger animation objects like wipe, push, fade etc

17. DL Renderer

- Resident software for DeckLink card

18. Hot Keys

- a. To edit CG pages conveniently

▶ PPT-100

Scan Converter Software

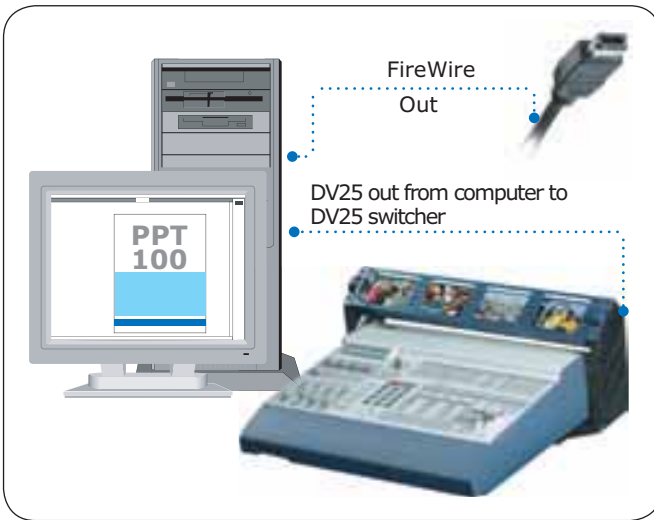

PC Minimum Requirements

- CPU P4 3.0Ghz or above
- Memory 512MB or above
- Screen Display 1024x768/32 bits colors
- OS Windows XP-SP2
- DirectX 9.0c

PPT-100 is a Scan Converter software that converts VGA display of your computer to DV25 video. It works with PowerPoint, Word, Excel, etc.

Note: Because this is a software only solution, the speed and RAM of your computer will affect performance.

We recommend that you test the trial version on our web site.
www.datavideo.us

Converting PowerPoint® files to high quality video is no longer a time consuming necessity.

All native PowerPoint effects and transitions are preserved.

Datavideo's PPT-100 software converts PowerPoint to DV

- For NLE editing, capture the DV stream from into your NLE or DV recorder.
- For live editing, use the PPT-100 as an input to your switcher.

Not Editing with DV?

Use DAC-6 to convert DV to Composite, Component or S-Video.

Direct Transfer of VGA to DV-25

- Flicker Free.
- Video position and size adjustment.
- Simple interface.

All you need is...

Datavideo PPT-100 software.
PC with Pentium 4 with 3+ GHz processor.
1024 x 768 32bit Graphics Card.
IEEE 1394 card in your computer.
Windows XP, Service Pack 2 Direct X 9.0C.

▶ SE-800 Remote Control

Local & Network via PC



RS 232-L

The entire SE-800 is on your PC desktop.
Works with Window 2000 and XP.
This software only solution is available for free. Please visit our website to download.



RMC-120

PC/NETWORK control of the SE-800. Works with Window 2000 and XP.
Firmware upgrade may be needed. Available free.
Please visit our website for more details.



TLM-404

LCD Monitor

The TLM-404 has four 4" TFT/LCD displays in a 2U, tilting, 19" rackmount. It can tilt +/- 30° and lock in any position. Controls include: Contrast, Brightness, Color, and Tint (NTSC only) Composite Video.

Included Accessories

- Allen Wrench (1.5 mm)
- Allen Wrench (2.5 mm)
- Instruction Manual (1)
- BNC Cable 4ft/1.22m (4)
- Power Adapter (1)
- Power Cord (1)

TLM-404 Specifications

VIDEO I/O	Composite Video 1.0Vp-p, 75 ohm/ Loop-through with 75 ohm self terminated, 1.0Vp-p output at 75 ohm load
VIDEO CONTROLS	Contrast, Brightness, Color and Tint (NTSC only) Composite Video NTSC/PAL B
VIDEO FORMATS	
VIDEO STD NTSC/PAL B TALLY	auto-sensing Yes
LCD DISPLAY	4" TFT/LCD Active Matrix 480 x 234 pixels.
RESOLUTION	
VIEWING ANGLE	Top:40°, Bottom:60°, Left: 60°, Right: 60°.
POWER INPUT	9-12VDC@3a

Unit Dimensions/Weight

Width:	19 inches, 482.6 mm
Depth:	3 inches, 76.2 mm
Height:	3.5 inches, 88.9 mm
Net Weight:	4 lbs, 2.0 kgs

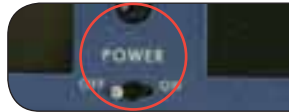

**TLM-404
Power
Switch**



TLM-404 Tilts



TLM-404 Video Loop



Recessed Controls



SE-800 Monitor Out
Each video input module has a Composite Output that can connect to the TLM-404



TLM-702

7" x 2 TFT LCD Monitor

The TLM-702 has four 4" TFT/LCD displays in a 4U, tilting, 19" rackmount. It can tilt +/- 30° and lock in any position. Controls include: Contrast, Brightness, Color, and Tint (NTSC only) Composite Video.

Included Accessories

- Allen Wrench (1.5 mm)
- Allen Wrench (2.5 mm)
- Instruction Manual (1)
- BNC Cable 4ft/1.22m (4)
- Power Adapter (1)
- Power Cord (1)

TLM-702 Specifications

VIDEO I/O	4* Composite Video 4:3, 16:9, Flip Mirror Image, Source Select, Brightness, Contrast, Color, Tint (NTSC ONLY)
VIDEO CONTROLS	NTSC/PAL B
VIDEO FORMATS	
VIDEO STD NTSC/PAL B TALLY	auto-sensing Yes
LCD DISPLAY	7" TFT LCD, Active Matrix 1440 X 234 Pixels 500 CD/MX2
RESOLUTION	
BRIGHTNESS	
CONTRAST RATIO	300:1
VIEWING ANGLE	Top:40°, Bottom:60°, Left: 60°, Right: 60°.
POWER INPUT	DC12V/20W (10.8 to 13.2 Volts)

OPERATING ENVIRONMENT

0°C to 50°C, RH less than 90%.

Unit Dimensions/Weight

Width:	19 inches, 482.6 mm
Depth:	2.5 inches, 63.5 mm
Height:	5.25 inches, 133.4 mm
Net Weight:	5 lbs, 2.3 kgs



Space saving connectors on the rear



Power: 12 VDC Input



Controls: Tally Lights



TLM-702 Tilts



**Controls: Tint, Color,
Contrast, Brightness**



RKM-4N7

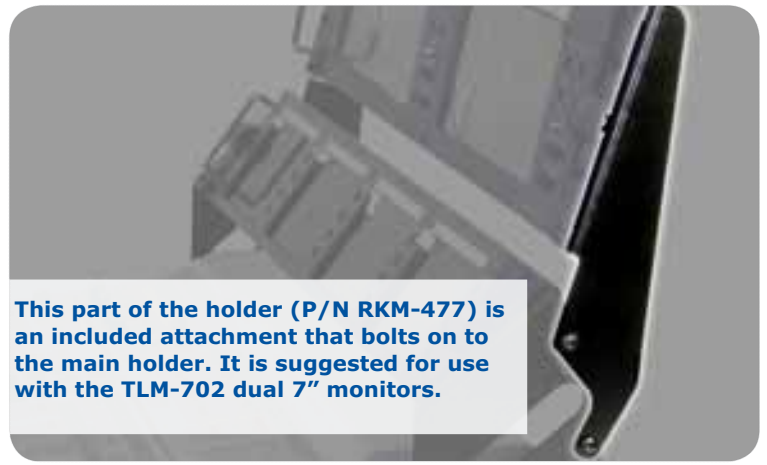

This part of the holder (P/N RKM-477) is an included attachment that bolts on to the main holder. It is suggested for use with the TLM-702 dual 7" monitors.



RKM-572



TLM-350



TLM-350



TLM-350



TLM-350



TLM-350

TFT LCD MONITOR

A small Composite Video monitor that tilts and twists in any direction. Includes a sunshade, 12v battery, nylon carry case and a small ball head that will mount in a camera shoe. It operates on 12 VDC.

TLM-350 Specifications

- VIDEO I/O**
2 x Composite Video / None
- VIDEO CONTROLS**
Source Select, Brightness, Mirror
- VIDEO FORMATS**
NTSC/PAL B
- VIDEO STD NTSC/PAL B**
auto-sensing
- TALLY**
No
- LCD DISPLAY**
3.5" TFT LCD, Active Matrix
- RESOLUTION**
480 X 234 Pixels
- BRIGHTNESS**
250 CD/MX2
- CONTRAST RATIO**
350:1
- VIEWING ANGLE**
Top:15°, Bottom: 35°,
Left: 50°, Right: 50°.
- POWER INPUT**
DC12V/3.6W (10.8 to 13.2 Volts)
- OPERATING ENVIRONMENT**
Operating temperature From
0°C to 50°C, RH less than 90%.

Unit Dimensions/Weight

- Width:** 3.5 inches, 88.9 mm
- Depth:** .88 inches, 22 mm
- Height:** 3.2 inches, 81.3 mm
- Net Weight:** .5 lbs, .23 kgs

Included Accessories

- Ball Head (BH-05),
- Li-Battery (1)
- Battery charger,
- Small battery bag
- Carrying Case
- Male to male DC cable

SUNSHADE



Case and a BH-05 Ball head





TLM-70D

7" DV Input LCD Monitor

The TLM-70D is a portable, DV25 input monitor with removable stereo speakers and a small audio amp. It includes a built in DV25/Analog converter that will let you connect additional monitors or test instruments.

Back View



TLM-70D Specifications

VIDEO I/O

1394 DV25, Composite Video/
1394 DV25, Composite Video
(Looped or converted from DV25)

VIDEO CONTROLS

4:3, 16:9, Flip mirror Image,
Source Select, Brightness,
Contrast, Color, Tint (only in NTSC).

7.5/ 0 IRE

Switchable

VIDEO STD NTSC/PAL B

auto-sensing

TALLY

Yes

AUDIO INPUTS

Unbalanced RCA, Audio in the DV25 stream.

AUDIO OUTPUTS

Unbalanced RCA, Audio in the DV25 stream,
Earphone, 1W additional speakers.

AUDIO CONTROLS

Earphone & speaker level.

LCD DISPLAY

7" TFT LCD, Active Matrix

RESOLUTION

480 X 234 Pixels

BRIGHTNESS

300 NITS

Unit Dimensions/Weight

Width:	7.5 inches, 190.5 mm
Depth:	2.5 inches, 63.5 mm
Height:	5.5 inches, 139.7 mm
Net Weight:	3.5 lbs, 1.8 kgs

Included Accessories

Power Supply 110/220 12VDC

BNC 4ft/1.22m (1)

2266 6/6p,1.8m(1)

2264 6/4p,1.8m(1)

Power Cord
Carrying Case



Removable sunshade



1/4x20
threaded
hole for
tripot screw



Tilting
handle



TLM-700

7" TFT LCD Monitor

The TLM-700 is a portable, analog input monitor with two Composite Video inputs.

Back View



TLM-700 Specifications

VIDEO I/O

2 x Composite Video / None

VIDEO CONTROLS

Source Select, Brightness, Mirror
Tint (only in NTSC)

VIDEO FORMATS

NTSC/PAL B

VIDEO STD NTSC/PAL B

auto-sensing

TALLY

No

LCD DISPLAY

3.5" TFT LCD, Active Matrix

RESOLUTION

480 X 234 Pixels

BRIGHTNESS

250 CD/MX2

CONTRAST RATIO

350:1

VIEWING ANGLE

Top: 15°, Bottom: 35°,
Left: 50°, Right: 50°.

POWER INPUT

DC12V/3.6W (10.8 to 13.2 Volts)

OPERATING ENVIRONMENT

Operating temperature from
0°C to 50°C, RH less than 90%

Unit Dimensions/Weight

Width:	5 inches, 127 mm
Depth:	1.5 inches, 38.1 mm
Height:	7.26inches, 184.4 mm
Net Weight:	1.5 lbs, 0.8kgs

Included Accessories

Power Supply 110/220 12VDC

BNC 4ft/1.22m (1)

Power Cord

Removable Sunshade



Carrying Case



Tripod Screw

DV Cables



4 male/6 female adapter
0.3m/12 inches, P/N CA64,
4 male to 6 female

This cable will connect a 4 pin jack on a camera or recorder with a 6 pin cable.

FireWire Cables for 200 MBPS Video

- 1.8m/5.91 feet P/N CA2264, 4 male to 6 male
- 1.8m/5.91 feet P/N CA2266, 6 male to 6 male
- 10m/30 feet, P/N CA1066, 6 male to 6 male
- 20m/60 feet, P/N CA2066, 6 male to 6 male

Cable length is no longer a reason for not shooting FireWire. These cables are rugged and guaranteed to work with DV25. For extended lengths in harsh environments, we suggest covering the repeaters with heat shrink tubing.



You may join Datavideo brand DV25 cables with our DV Repeater and separate your DV25 devices by hundreds of feet.
60m = 196.85 feet

DV Repeater



VP-314 DV Repeater

The VP-314 receives its power from another device in the DV25 Stream. For example, the SE-800 or all of the DAC format converters add power through the 6 pin connector. Cameras with 4 pin connectors do not add power. Some cameras with 6 pin connectors may add power.

Unit Dimensions/Weight

- Width: 5.75 inches, 146 mm
- Depth: 0.75 inches, 19 mm
- Height: 1.375 inches, 35 mm
- Net Weight: 4 ounces, 113 gr

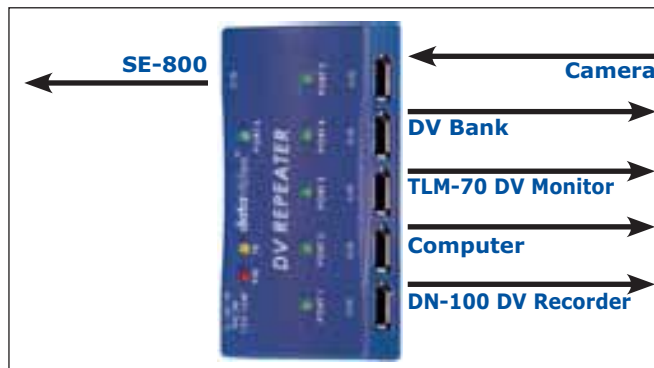

VP-332 DV Repeater

The VP-332 DV repeater must be used with one DV25 input only. It will take a single input and "resend" it to the five other ports on the unit. Because it is expecting just one "source", there will be a device conflict if you connect two cameras or other devices that present themselves as sources.

Unit Dimensions/Weight

- Width: 4 inches, 98 mm
- Depth: 2 inches, 52 mm
- Height: .75 inches, 18 mm
- Net Weight: 2.5 ounces, 70 gr



DN-100

DV Recorder

The DV Bank is an instant on, easy to use FireWire video recorder/player with a built in hard drive.

VTR-like controls with large, illuminated buttons, and a two line backlit LCD display let the user select play, record, rewind, fast forward, fast reverse, pause, frame advance, file selection, file delete and loop play.

Its FireWire (IEEE-1394) interface allows direct capture from digital camcorders, other digital sources.

Included Accessories

Download Cable (2), Power Cord, 2266 6/6P, 1.8M (1), 2264 6/4P, 1.8M (1)
Power Supply 110/220 12VDC
Remote Control

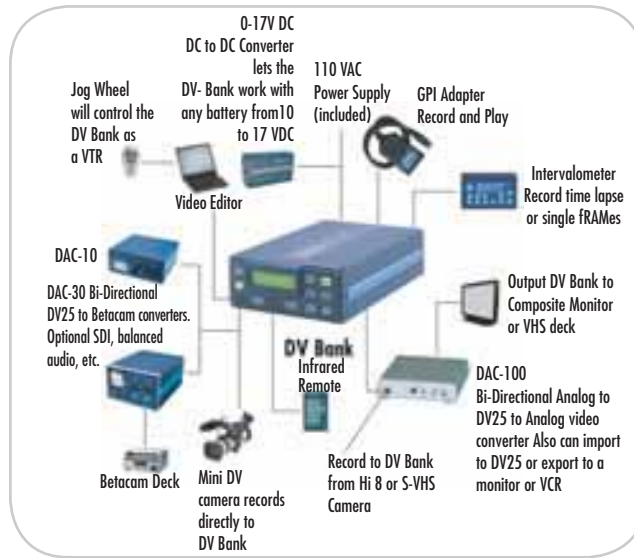

Unit Dimensions/Weight

Width: 6.7 inches, 170 mm
Depth: 10 inches, 254 mm
Height: 2.8 inches, 70 mm
Net Weight: 4.5 lbs, 2.0 kgs

Compatible Accessories



TL-1
Intervalometer
Time Lapse Controller



DAC-100



DV Bank
Infrared Remote



DC Stabilizer



DAC-10



EZ Cut Edit
Software

DAC Format Converters - **DV** ANALOG

					
	DAC-200	DAC-30	DAC-15	DAC-6	DAC-5
All DAC's are available for a FREE DEMO call (562) 696-2324 E-mail: contactus@datavideo.us					
SMART DV	YES	YES	YES	NO	NO
HOW MANY DV JACKS?	2	3	2	2	2
Y/C (S-Video) & COMPOSITE IN & OUT	YES	YES	YES	OUT ONLY	OUT ONLY
COMPONENT (Y/R-Y/B-Y) I/O (BETACAM)	NO	YES	YES	OUT ONLY	OUT ONLY
COLOR PROCESSOR CONTROL	NO	YES	YES	NO	NO
AUDIO INPUT LEVEL CONTROL	NO	YES	YES	NO	NO
NTSC/PAL B SELECTABLE	YES	YES	YES	YES	YES
0/7.5 IRE SELECTABLE	YES	YES	YES	YES	YES
BALANCED AUDIO IN/OUT	NO	YES	NO	NO	NO
UNBALANCED AUDIO IN/OUT	YES	YES	YES	NO	OUT
AUDIO METERS	NO	YES	YES	NO	NO
TBC BUILT-IN	NO	YES	NO	NO	NO
SDI IN & OUT (SMPTE 259M)	NO	YES	NO	NO	YES
COLOR BAR GENERATOR	YES	YES	YES	NO	NO
RS-422 INTERFACE	NO	YES	YES	NO	NO
BLACK BURST OUT	NO	YES	YES	NO	YES
LOCKED/UNLOCKED AUDIO	YES	YES	YES	YES	YES
POWER	DC5V/6W	DC12V/18W	DC12V/10W	DC12V/6W	DC12V/12W
RACKMOUNT	NO	DAC-30R MODEL	YES	NO	YES
UNIT DIMENSIONS/WEIGHT	6.15" X 6.0" X 1.6" 0.88 LBS	8" X 10.25" X 5.25" 7 LBS	8.25" X 8.25" X 3.5" 4 LBS	4" X 6.5" X 2" 1 LBS	8.25" X 8.25" X 3.5" 4 LBS



DAC-200

Media Format Converter

Bi-Directional DV25/Analog Video - Y/C (S-Video), Composite Video, NTSC/PAL B selectable, and selectable audio sampling rate.

Included Accessories

- 2264 6/4P, 1.8m (1)
- RCA 5ft/1.52m (1)
- Power Supply 110/220 5VDC
- S-Video 4ft/1.22m (1)



DV → **Composite.**
 → **S-Video**
 → **Unbalanced Audio**

Bidirectional

Unit Dimensions/Weight

Width: 6 inches, 15.5 mm
Depth: 6 inches, 15.5 mm
Height: 1.5 inches, 3.5 mm
Net Weight: .5 lbs, .4 kgs

Inputs

DV25, Y/C (S-Video), Composite.

Outputs

DV25, Y/C (S-Video), Composite.
 Selectable video level, at 0 IRE or 7.5 IRE.
 Video comb filter for high quality video.
 Video input source auto-detection.

AUDIO SAMPLING RATE

Selectable 32KHz (12-bit) or 48 KHz (16-bit) for unbalanced audio.

COMPUTERS

Macs, Windows 98 / ME / 2000 and XP.

Features

SELECTABLE VIDEO STANDARD

NTSC (525 lines / 60Hz),
 PAL B (625 lines/50Hz)



Analog Audio Output

Two unbalanced audio RCA connectors.

Composite Video Output

S-Video Output

Dip Switches

FireWire Input/Output



FireWire Input/Output

S-Video Input

Composite Video Input

School Studio

Rationale:

Live video production is an intellectual "team sport" that develops student technical skills and social skills. And, because of the immediate feedback from live editing and peer pressure to succeed, the academic knowledge necessary for live presentation is important to the student.

Computerized video editing is also an essential teaching method but it develops different skills and does not offer the immediate feedback of live production.

All Datavideo products are "tested" by children around the world for ease of operation and abuse tolerance.

Support for schools:

Datavideo will work directly with schools to suggest the best equipment choices and arrange demo products. We offer free technical support by email. Purchases should be made through your favorite reseller.





DAC-5

SDI to/from DV Digital Video Converter

DAC-5 converts SDI video and AES/EBU audio to and from FireWire DV25 audio/video. The DVITC timecode in the output signal respects the same standard as the one in the input signal.

Included Accessories

- 2264 6/4P, 1.8m (1),
- 2266 6/4P, 1.8m (1)
- BNC 4ft/1.22m (4),
- RCA 5ft/1.52m (1),
- AES Adaptor (1),
- Y/C (S-Video) 4ft/1.22m (1),
- Power Supply 110/220 12VDC

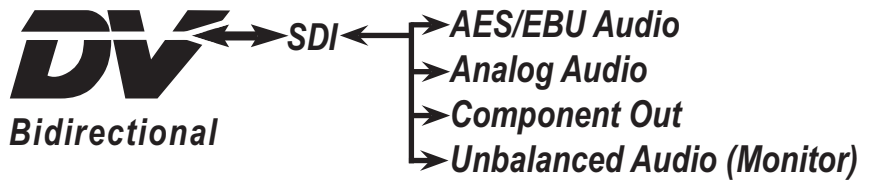

Unit Dimensions/Weight

Width: 8.25 inches, 209.55 mm
Depth: 8.25 inches, 209.55 mm
Height: 3.5 inches, 88.9 mm
Net Weight: 6 lbs, 2.8 kgs



12 Bit or 16 Bit Audio



SDI or DV25 Input



Dip Switches
PAL B/NTSC,
0/7.5 IRE



Blackburst
Output



Component
Output (YUV)



Digital Audio I/O



Digital: DV I/O



Video & Audio Monitoring



Digital: SDI I/O



DAC-6

One way DV to Analog Video Converter

Included Accessories

- RCA 5ft/1.52m (1)
- Y/C (S-Video) 4ft/1.22m (1)
- BNC 4ft/1.22m (3)
- 2266 6/4P, 1.8m (1)
- Power Supply 110/220 12VDC



Unit Dimensions/Weight

Width: 4 inches, 101.6 mm
Depth: 6.5 inches, 165.1 mm
Height: 2 inches, 50.8 mm
Net Weight: 1 lbs, 0.45 kgs



Y/C (S-Video)
Output



Audio



Component
Output



Composite Output

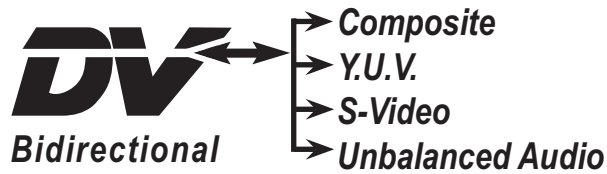

DAC-15

Media Format Converter

Bi-Directional DV25/Analog Video – YUV Y/C (S-Video), and Composite Video features: Audio Level, Video Color Adjustments, Blackburst Generator, NTSC/PAL B selectable and more.

Included Accessories

- 2264 6/4P, 1.8m (1)
- 2266 6/4P, 1.8m (1)
- BNC 4ft/1.22m (4)
- RCA 5ft/1.52m (1)
- Y/C (S-Video) 4ft/1.22m (1)
- Power Supply 110/220 12VDC

Unit Dimensions/Weight

- Width:** 8.25 inches, 209.55 mm
- Depth:** 8.25 inches, 209.55 mm
- Height:** 3.5 inches, 88.9 mm
- Net Weight:** 6 lbs, 2.8 kgs



Color Adjustment Works on all formats Audio Input Level



Push Buttons to Select Video Input & Output



Digital: DV25 (IEEE 1394) I/O

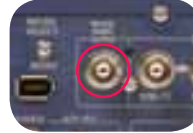

Analog Video Blackburst Output



Component Video (Y/R-Y/B-Y) I/O



RS-422 control



Composite Video I/O Y/C (S-Video) I/O Unbalanced Audio I/O



Rackmount for Two DAC-10's

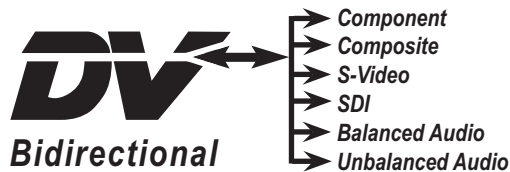

DAC-30

Media Format Converter

Bi-Directional DV25/Analog Video - SDI, YUV Y/C (S-Video), and Composite with Balanced Audio.

Features: Audio Level Adjustment, Video Color Adjustments, Black Burst Generator, NTSC/PAL B selectable, RS422 and more. Available in rack-mount or desktop configuration.

Included Accessories

- 2264 6/4P, 1.8m (1), 2266 6/4P, 1.8m (1)
- BNC 4ft/1.22m (4), RCA 5ft/1.52m (1)
- Y/C (S-Video) 4ft/1.22m (1), Power Cord,
- Power Supply 110/220 12VDC
- Digital AES Adaptor (1), Serial 9PIN (1)

DAC-30 Unit Dimensions/Weight

- Width:** 8 inches, 205 mm
- Depth:** 9.8 inches, 250 mm
- Height:** 5.2 inches, 132 mm
- Net Weight:** 6 lbs, 2.8 kgs



Audio Input Level Meters



Analog & Digital Video Input

DAC-30R Unit Dimensions/Weight

- Width:** 17 inches, 431.8 mm
- Depth:** 11.37 inches, 288.93 mm
- Height:** 3.5 inches, 88.9 mm
- Net Weight:** 8 lbs, 3.8 kgs



Color Adjustment Audio Input Level



RS-232 Control AES/EBU



DAC-30R



Audio: Balanced Audio I/O, Unbalanced Audio I/O



Composite Video I/O, Y/C (S-Video)



Component Video output (Y/R-Y/B-Y) Black Burst Output



Component Video Input (Y/R-Y/B-Y)



SDI I/O



SE-500

4 Input Switcher

Everything you need to switch and monitor four Composite or Y/C (S-Video) sources. Sophisticated monitor functions show you quad, split, next source and next effect. This small, rugged switcher is ideal for educational and security applications.

Included Accessories

- Y/C (S-Video) 4ft/1.22m (1) BNC to RCA (2)
- BNC to RCA Connector (2)
- RCA Stereo (1) YUV Cable (1)
- Power Supply 110/220 12VDC

SE-500 Specifications

- VIDEO IN**
4 Composite or Y/C (S-Video)
- VIDEO OUT**
2 Composite and 1 Y/C (S-Video)
- VIDEO MONITOR OUT**
1 Quad preview

- VIDEO OUT OPTION**
Two Composite Video outputs.
The monitor out may be reassigned as a component (Y/R-Y/B-Y) output

- VIDEO TALLY OUT**
DB15 connector
- RS232 CONTROL**
DB9 connector

- AUDIO IN**
2 line level, unbalanced,
2 microphone 1/4"
- AUDIO OUT**
2 line level, unbalanced

Unit Dimensions/Weight

- Width:** 15.7 inches, 400 mm
- Depth:** 9.8 inches, 250 mm
- Height:** 3.2 inches, 80 mm
- Net Weight:** 4.4 lbs, 2.0 kgs



Preview Out
Source Status:
Program=Red,
Next=Yellow
Effect:
Select Effect,
BKG:
Selected Color



Wipe Patterns



No Genlock Required
Dual channel TBC and
4:2:2 frame synchronizer
built-in.

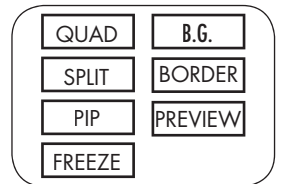

Digital Effects
A/B Roll, A/B Dissolve, Quad,
Freeze, Split, PIP with Borders.
Two PIP size with borders:
Small PIP: 243(W) x 162 (H)
Large PIP: 288(W) x 194 (H)



RKM-572



RS-232 Control



Tally Out



MIDI Control



Microphone Inputs



Audio I/O



12V DC in 1.5 amp



Preview out, Selects
between Sub
Source or Effect



4 Inputs Composite
Video or
S-Video



3 Outputs, 1 Y/C (S-Video),
2 Composite, Preview
and Composite Outputs
may be assigned as
(Y/R-Y/B-Y)
Component Out

Accessories



DAC-6



DVK-100



TLM-702



Y/C (S-video)
Cables



TB-5
Tally box for SE-500
includes 4 LED tally lights
that attach to any camera



SE-500 Rear View

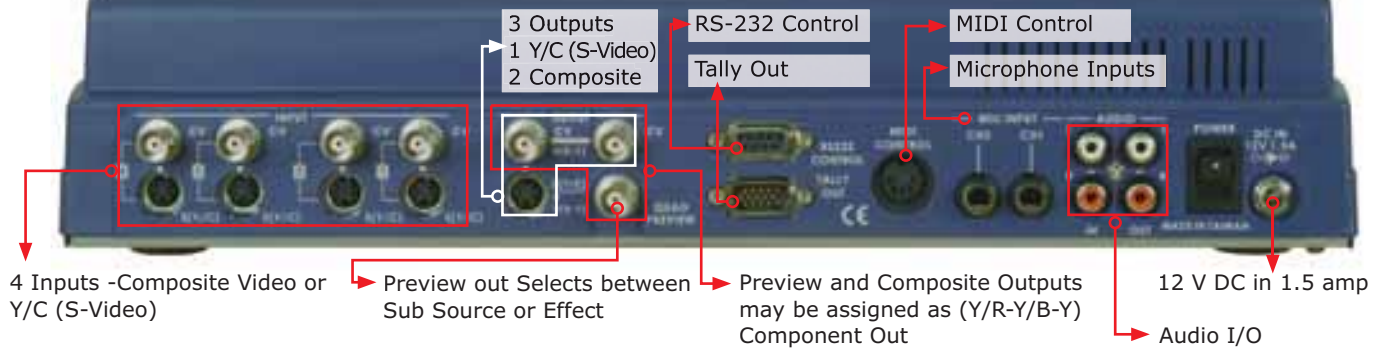

Use the DVK-100 to make video of an imaginary motorcycle ride and include an introductory video at the beginning of the DVD.

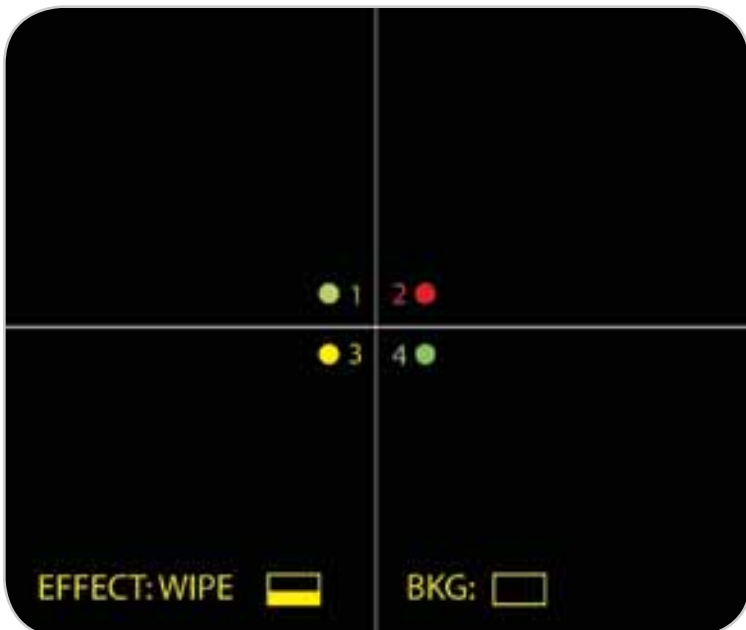

SE-500 What to Order

This is a list of many of the things needed to set up a small studio. We offer it as a specific list of Datavideo products and a starting point in general.

PRODUCT	MSRP	
LIGHTS		
SE-500 This model accepts four analog Composite or Y/C (S-Video) inputs (NTSC).	US\$ 1,050	
TLM-702 Monitor & Holder Kit SE-500	US\$ 1,150	
TLM-702 Monitor - 2 x 7" LCD display used with the RMC-140 this dual 7" LCD display will show you the "next" source as well as the program out.	US\$ 850	
CA22644/6 DV cable	US\$ 12	
CA2066 - 20 meter DV Cable 6 pin.	US\$ 75	
VP-314 DV Repeater , self powered. This repeater operates on the 12VDC that is available when connected to the SE-800. Note: Each SE-800DV comes with four adapters that will allow you to connect a 6 pin DV cable to a 4 pin camera.	US\$ 60	
Analog Video Cables - Be sure to budget for these cables or DV cables.		
TB-5 Tally Box for SE-500	US\$ 149	
TDXT25 Tally Light Extension Cable 25 ft.	US\$ 25	
DAC-6 Converts DV to Y/C (S-Video) for input to SE-500	US\$ 249	
ITC-1 - Intercom This 8 channel cable connected intercom will let one central person contact each or all of up to 8 others. Basic kit includes all that you need for four users and home base. See web/product guide page for details.	US\$ 999	
PD-1 - Power Distributor No more wall warts . PD-1 powers everything around and including the SE-800. See web/product guide page for details.	US\$ 699	
DVK-100 Chromakey - See web/product guide page for details.	US\$ 1,200	
Background - See web/product guide page for suggestions.		
Production / Shipping Cases - See web/product guide page for details.		
CG-100 Character Generator Software & DeckLink Card - The CG-100 works with a Blackmagic DeckLink PRO card installed in a PC. The system may be set up as a downstream keyer (DSK) to take Y/C (S-Video) out from the SE-500 or as an upstream keyer to place text over one incoming Y/C (S-Video) source.	US\$ 1,499	
PC - For the CG-100 - Don't forget this item - see CG-100 page for minimum requirements.		
MP-6000 Direct to DVD burner	US\$ 1,299	





DVK-100

Chroma Key

Can you believe it? US\$ 1,200 for a Y/C (S-Video) / Composite Chromakey. It's available for demo. Just ask your favorite reseller.

Included Accessories

- BNC 4ft/1.22m (1)
- Y/C (S-Video) 4ft/1.22m (2)
- Power Supply

Unit Dimensions/Weight

Width:	8.25 inches, 210 mm
Depth:	8.25 inches, 210 mm
Height:	3.5 inches, 88.9 mm
Net Weight:	4 lbs, 2 kgs

Specifications

3 INPUTS:

CAM-1/CAM-2 INPUT--
For foreground use (FG)
BG INPUT-- For background use (BG)

EACH INPUT CAN SELECT COMPOSITE OR Y/C (S-Video) SIGNAL:

Y/C (S-Video) in 4-pin 75 ohm DIN Connector Composite in 75 ohm RCA connector, level: 1.0Vp-p

Output:

SIMULTANEOUS OUTPUT:

1 Y/C (S-Video) out

2 Composite out

OUTPUT MODE:

FG or FG with BG: Choose Chroma key ON or OFF

LOOP THROUGH OUT:

Composite out from Y/C (S-Video) in or Composite in Y/C (S-Video) out from Y/C (S-Video) in only

General

POWER INPUT DC:

12V/1.5A (AC adapter included)

RS-232 & GPI INTERFACE:

for remote control

AMBIENT HUMIDITY:

Less than 90%

Features

- * 2 camcorder inputs for foreground and 1 for background input.
- * Key out background, color selectable (Blue, Green, or luminance).
- * Key out level, adjustable to reduce shadow after keying.
- * Y/C (S-Video) and Composite input and output.
- * Window adjustable to fit different sizes of background screen.
- * Built-in Shrink function (Reduce white or black color edge on subject.)
- * Built-in Spill function (Adjust spill suppression.)
- * Built in Density (Adjust selected color key transparency.)
- * Built-in Color Processor, Brightness, Contrast, Color, and Tint adjustable (Tint is NTSC only)
- * Built in TBC
- * RS-232 interface for control from other RS232 devices.
- * GPI trigger interface for switching two different camera foreground sources.



Rear View

CB-2 Y/C (S-Video) to BNC Adapter

Use two of these adapters when you need a long Y/C (S-Video) cable run and want the best quality.



Uses Y/C (S-Video)

DV25 compresses and combines color and luminance information into small data packages for convenient transmission and storage. Decompressing for a chromakey adds cost without quality. A component video like "Y/C (S-Video)" is better for chromakey.



Selectable Background Window Crop

Adjust the size of the area that is cropped by the chromakey.



2 Camera Input and 1 Background Input

With two camera inputs, you can seamlessly cut between a full shot and a close up while you keep the background. This can make your video more believable. Includes a GPI trigger to switch between sources. The video signal loops through the DVK-100 so you can monitor each camera before cutting between them.



Edge Halo Shrink Function

Built in edge halo shrink function (reduce white or black color edge on subject)

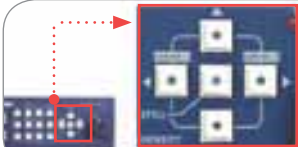

Selectable Background Colors

Uses standard BLUE, GREEN or BLACK backgrounds or special ones with retro reflective screens and led rings around the lens.



Build in Color Processor & TBC

Limited color tweak capabilities and TBC.



Use DV - Add a DAC-200

MSRP for the DAC-200 is US\$200





+



=



+



=



NEWSRUSH Anchor Kiosk
Controlled by EYE STUDIO - AEB FOR ALL MEDIA

- PTZ silent camera
- Integrated Prompter
- 2-channel server
- Switcher control
- Character Generator with animation
- Touch screen anchor selection
- Automated rundown
- Instant replay
- Automated VTR copies
- Automated DVD copies with silent picture on label



Using the Datavideo DVK-100 Chromakey can add a sense of fun and interest to any video presentation.



Getting Optimum Chromakey Results

Background Types

A Chromakey works by recognizing a single video color (blue, green or black and replacing those pixels with a background image.

Paper

Paper is the easiest, least expensive and fastest temporary solution. In the US, the primary manufacturer is Savage.
www.savagepaper.com

Paint

Paint is the easiest permanent solution. The main US manufacturer is Rosco.
<http://www.rosco.com>

Home Supply store paint is usually not optimized for low reflection.

Cloth

Regular cloth and foam backed cloth are available. The regular cloth is a smaller package but requires that you remove the wrinkles before use. The foam backed material does not show wrinkles and is easy to use.

Cyclorama

A formed background that curves between the wall(s) and floor. This is a more permanent solution although portable ones are available.

Retroreflective Backgrounds

Using the same theory as traffic signs, this material reflects light back toward the source where it came from. With a ring of LED's surrounding the camera lens you can use a small amount of light to illuminate just what the camera sees. Usually it will help if you "back light" the subject(s) to make it easier for the chromakey to distinguish between background and foreground.

Wide Angle lenses – yes or no?

Camera lens focal length will affect the size of the background you must use. A wide angle lens requires a larger background.

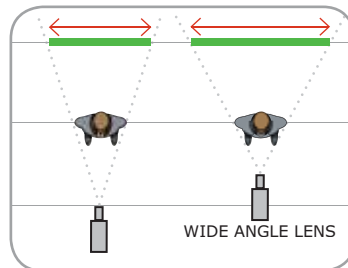

Lighting

You can quickly get the best results by being able to measure and control your lights. In general we suggest that more light is better than less light but it must be well balanced, i.e. a bright background and dim subject will not give optimum results.

How do you measure lighting?

Use a light meter. The idea is to get even illumination on the background. Do not use your eyes to judge the evenness of illumination. Once you have the best illumination you can get, then you can adjust the Chromakey to compensate for differences.

Flat lighting for the background.

Chromakeys work best with lots of flat, even light. It may be difficult to illuminate the whole background so it is even. The DVK-100 may be adjusted to crop out all except the area behind the people or objects that you want to separate (from the background).

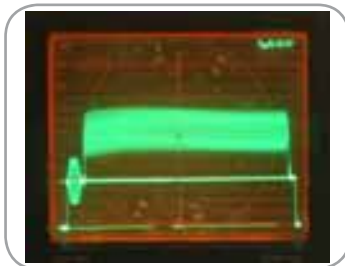

Natural lighting for the people

We are used to seeing each other with a main or key source and a fill source. Flat lighting on the people will appear less natural. You should be able to light the people without affecting the background.

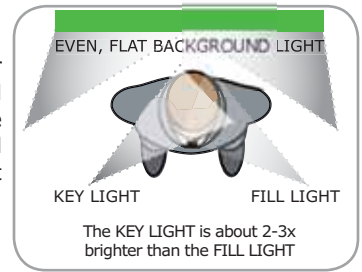

Balance the light levels

You will get better results if the light on the background and the light on the subject are of similar brightness levels.

Light brightness

Light brightness is like sound. The closer you are to the source, the more there is. Light spreads out rapidly with distance.

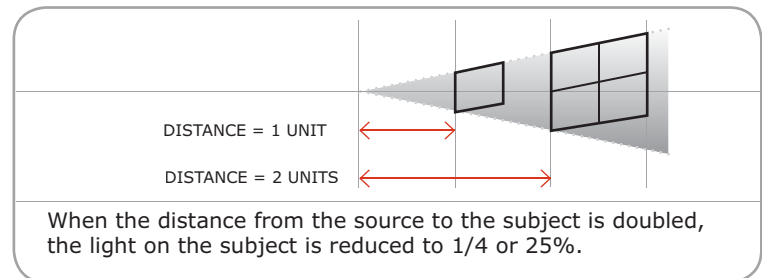

With more light, the camera electronics will work less (theoretically) the signal has less noise. Less expensive cameras can look better with more light. More light also means that the lens is stopped down more and that the depth of field is greater i.e. more is in focus.

Light vocabulary

One footcandle is the illuminance at a point on a surface which is one foot from, and perpendicular to, a uniform point source of one candela.

One lux is the illuminance at the same point at a distance of 1 meter from the source.

One lumen uniformly distributed over one square foot of surface provides an illumination of 1 footcandle.

If you work in feet, your results will be in footcandles - (1 footcandle = 1 lumen/square ft.)

If you work in meters, your results will be in lux - (1 lux = 1 lumen/square meter)

The edge that separates the foreground from the colored background.

We suggest that you experiment with the illumination ratios using your particular screen and setup.

If the green/blue screen is brighter than the subject, what does the edge look like?

If they are about equal, what does the edge look like? How does lighting the back of the subject affect the edge?

DVK-100 Instruction book

We've given you concepts and ideas. Please read the instruction book for the best results from your Datavideo DVK-100.



MP-6000 DVD+R/RW Recorder

The MP-6000 records DVD+R/RW DVD's direct from most A/V sources, including cameras and analog VCR's. Using a high performance MPEG2 codec, you can select the bit rate for higher quality or more recording time. The created DVD discs can be played in most existing DVD players.

Unit Dimensions/Weight

Width: 11.75 inches, 190.5 mm
Depth: 8 inches, 139.7 mm
Height: 5.5 inches, 63.5 mm
Net Weight: 9 lbs, 4.2 kgs

Features

- * Real Time Stand Alone DVD Recorder/ Player.
- * VTR Controls and Formats.
- * Built in Video Processor with Color Correction.
- * Variable Bit Rate Recording.
- * RS-232 Remote Interface.
- * Direct to DVD Recording.

Included Accessories

2264 6/4P, 1.8m (1)
 2266 6/4P, 1.8m (1)
 BNC 4ft/1.22m (4)
 RCA 5ft/1.52m (1)
 Y/C (S-Video) 4ft/1.22m (1)
 Power Cord
 Power Supply 110/220 12VDC

More Accessories

DVD+RW Disc
 User Manual
 AC Adaptor
 Video Cables
 Stereo Audio Cable
 IR Remote Control

Functions

One Touch Record, Append, Erase, Automatic/Manual Chapter insertion, Disc Write, Protection, Instant Content Menu Access, Selectable Index Pictures.



Component Video (Y/R-Y/B-Y) and Black Burst Output



Component (Y/R-Y/B-Y) Input



Balanced Audio Input



Unbalanced Audio I/O

MP-6000 Front View

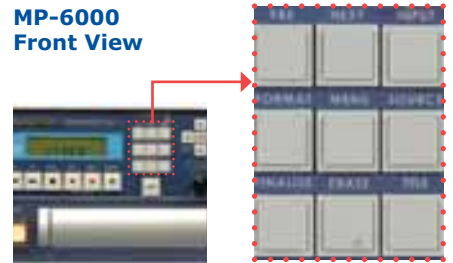

AUDIO IN	AUDIO OUT
UNBALANCED (RCA)	UNBALANCED (RCA)
BALANCED (XLR)	BALANCED (XLR)

VIDEO IN	VIDEO OUT
DV25	DV25
COMPONENT	COMPONENT
COMPOSITE (ANALOG)	COMPOSITE (ANALOG)
Y/C (S-VIDEO)	Y/C (S-VIDEO)

AUDIO FORMATS - AUDIO PERFORMANCE D/A=24 BIT, A/D=16 BIT		
DVD	96 KHZ	4 HZ-44 KHZ
	48 KHZ	4 HZ-22 KHZ
VIDEO CD	44.1 KHZ	4 HZ-20 KHZ
AUDIO CD	44.1 KHZ	4 HZ-20 KHZ

VIDEO FORMAT	DVD, SVCD, VCD	MPEG2, MPEG1
DVD-VIDEO & DVD+R/RW		
HORIZONTAL RESOLUTION	720 PIXELS	740 PIXELS
VERTICAL RESOLUTION	576 LINES	480 LINES
DVD+RW (LP/EP)		
HORIZONTAL RESOLUTION	360 PIXELS	360 PIXELS
VERTICAL RESOLUTION	576 LINES	480 LINES
VCD		
HORIZONTAL RESOLUTION	352 PIXELS	352 PIXELS
VERTICAL RESOLUTION	288 LINES	240 LINES

MP-6000 DVD+R/RW DISC RECORDING SPEC:					
DVD+R/RW RECORDING MODE		VIDEO RESOLUTION H-PIXELS X V-LINES		EST RECORDING TIME ON A 4.7GB DVD+R/RW DISC	
MODE	BIT RATE	PAL B/50HZ	NTSC/ 60HZ		
HQ	9.17 MBPS	720 X 576	720 X 480	60 MINUTES	
SP	5.07 MBPS	720 X 576	720 X 480	120 MINUTES	
LP	3.38 MBPS	480 X 576	480 X 480	180 MINUTES	
EP	2.54 MBPS	360 X 576	360 X 480	240 MINUTES	
SLP	1.69 MBPS	352 X 288	352 X 240	360 MINUTES	



DISC TYPES	PLAY	RECORD
DVD+RW	Y	Y
DVD+R	Y	Y
DVD-R	Y	N
DVD-RW/VIDEO	Y	N
DVD/VIDEO	Y	N
SUPER VCD	Y	N
VIDEO CD	Y	N
AUDIO CD	Y	N
CD-R	Y	N
CD-RW	Y	N



This MP-6000 is used by Klasky Chewpo animation (Los Angeles) to make DVD video work prints for their animation customers.



TBC'S

All TBC's use an internal crystal to regenerate the video synch signals and stabilize the video. There is no provision for external genlock. With black and white video, a color reference signal (color burst) is required. Each TBC includes an internal full frame memory buffer for synchronization.

Time Base Correctors			
	TBC 100	TBC 1000	TBC 3000
BUILT IN VIDEO AND AUDIO DA		YES	
NTSC/PAL B AUTO DETECT	YES	YES	
COMPOSITE VIDEO I/O	YES	YES	YES
Y/C (S-VIDEO) I/O	YES	YES	YES
CHANNELS	1	1	2
CHROMA KEY 16 COLORS/15 STEPS			
VIDEO LEVEL CONTROLS			
COLOR BAR & PATTERN GENERATOR			YES
FREEZE FRAME			
VOLTAGE	5/12 VDC	12 VDC	9 VDC
POWER SUPPLY INCLUDED		YES	YES

Specifications

Wide bandwidth – Y/C (S-Video) 4.5MHz, Composite 3.5MHz,
8 bit, 4:2:2 sampling rate.
SN>50db

Time Base Correctors			
	TBC 4000	TBC 6000	TBC 7000
FITS IN PC			
BUILT IN VIDEO AND AUDIO DA			
NTSC/PAL B AUTO DETECT			
COMPOSITE VIDEO I/O	YES	YES	YES
Y/C (S-VIDEO) I/O	YES	YES	YES
CHANNELS	4	3	3
CHROMA KEY 16 COLORS/15 STEPS		1	2
VIDEO LEVEL CONTROLS		YES	YES
COLOR BAR & PATTERN GENERATOR	YES	YES	YES
FREEZE FRAME			
VOLTAGE	9 VDC	9 VDC	9 VDC
POWER SUPPLY INCLUDED	YES	YES	YES



VP-299 ANALOG AUDIO & VIDEO DISTRIBUTION AMPLIFIER

One in and four out, Stereo audio pairs, Y/C (S-Video) and Composite video.

Note: Does not convert between Y/C (S-Video) and Composite Video.

Unit Dimensions/Weight

Width: 8.4 inches, 210 mm

Depth: 8.4 inches, 210 mm

Height: 2.2 inches, 55 mm

Net Weight: 2.5 lbs, 1.12 kg



Unit Dimensions/Weight

Width: 19 inches, 482.6 mm
Depth: 5 inches, 127 mm
Height: 1.5 inches, 38.1 mm
Net Weight: 4 lbs, 2.8 kgs

AC Input

110/220 VAC 1.5 amp
 (or connect to the PD-1)
 Includes Tally indication on the
 belt packs.
 Includes chassis grounding screw
 for a common audio ground.

ITC-100

Intercom

An innovative, 8 remote user and base station intercom that can use low cost cell phone headsets or high quality, professional units.

Users are connected to the base station via belt packs and 20 meter audio cables (5 pin XLR connectors) that may be extended up to 300 meters.

Included Accessories

- Rack Mount Intercom (1),
- Gooseneck MIC (1)
- DJ lamp (1), 12V/1.5A Power Adaptor (1),
- Belt packs (4), 20m cables (4),
- Headsets (4),
- XLR mount gooseneck microphone
- XLR mount gooseneck light



ITC-1 Front View



ITC-1 Rear View

Optional Accessories
 p/n: CB-2 20m intercom & tally cable, p/n: CB-3 50m intercom & tally cable,
 p/n: CB-4 100m intercom & tally cable, p/n: HP-1 Small Cell phone headset,
 p/n: HP-2 Larger Cell phone headset, p/n: ITC-1 Additional belt packs with
 only 5 pin XLR, p/n: ITC-10S package of 1x belt pack, 1x 20m cable, 1x headset.



Belt packs



Cable



Cell phone headsets



Unit Dimensions/Weight

Width: 19 inches, 482.6 mm
Depth: 8.5 inches, 216 mm
Height: 1.5 inches, 38.1 mm
Net Weight: 8.5 lbs, 2.5 kgs

Output

10 DC output connectors
 2*4 pin XLR @ 12V/6 amps
 3* AC output connectors

Input

1*4 pin XLR @ 12V/300W

PD-1

Power Distributor

The PD-1 Power Distribution center eliminates wall warts and dangling power supplies. It can be powered by a DC supply (mobile) or by an AC supply.

Included Accessories

- 35" 12V Locking Connectors (2)
- 42" 12V Locking Connectors (1)
- 23" 12V Locking Connectors (1)
- 4 Pin Male to Female Adaptor (1)
- Power cord (1)



PD-1 Front View



PD-1 Rear View

Typical Application

The PD-1 can power all of these devices at the same time

- 1 - SE-800
 - 1 - MP-6000 DVD recorder and eight more devices including
 - 1 - TLM-404 (monitor)
 - 1 - TLM-702 (monitor)
 - 1 - RMC-140 next source preview and Tally Box
- And five more devices.

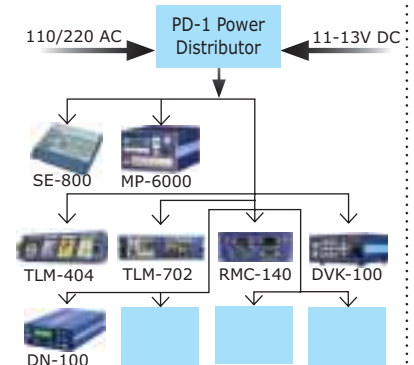



STC-100

Standards Converter

The STC-100 is a bi-directional video standards converter between NTSC and PAL B (not PAL M- or PAL N). It operates on 12 VDC and can be rack mounted.

Included Accessories

- 1.2M BNC Cable (3)
- Y/C (S-Video) (1)
- 12V DC Power Adaptor
(100-240V AC input - 12V 1.5 A output)

Unit Dimensions/Weight

- Width:** 8.25 inches, 210 mm
- Depth:** 8.25 inches, 210 mm
- Height:** 3.25 inches, 21 mm
- Net Weight:** 3.5 lbs, 1.6 kgs



Black Burst Output



Component Output



Composite Video I/O



Power



Component Input



DC In

Specifications

Input

Video Composite, Y/C (S-Video), YUV
Audio Stereo, Unbalanced, RCA

Output

Video Composite, Y/C (S-Video),
Black Burst
Audio Stereo, Unbalanced, RCA

Video Processing

Component
8-bit, 4:2:2, Y: 13.5MHz

Frame Synchronization

Full Frame TBC

Frequency Response (S input)

5 MHz +/-3dB

DG, DP

+/- 3%, 3°

S/N Ratio

>50 dB

Video Correction

Brightness +/- 10%
Contrast +/- 3dB
Color +3/-10dB
Tint +/- 10°(NTSC only)

Audio level calibration

S/N Ratio >60dB
THD <0.1%
Analog Bandwidth 20Hz~20kHz, +/- 3dB

Ambient Temperature

32°- 131°F (0°- 55°C)

Ambient Humidity

Less than 90%

The following countries use the **NTSC** system

Antigua	Dominican Republic	Peru
Bahamas	El Salvador	Philippines
Barbados	Ecuador	Puerto Rico
Barbuda	Guam	Saipan
Belize	Guatemala	Samoa
Bermuda	Haiti	South Korea
Bolivia	Honduras	Saint Kitts
Burma	Jamaica	Saint Lucia
Cambodia	Japan	Saint Vincent
Canada	Mexico	Surinam
Cayman Islands	Midway Islands	Taiwan
Chile	Netherland Antilles	Tobago
Colombia	Nicaragua	Trinidad
Costa Rica	North Mariana Island	United States
Cuba	Panama	Venezuela
		Virgin Islands

The following countries use the **PAL** system

Afghanistan	Iceland	Qatar
Albania	India	Romania
Algeria	Indonesia	Singapore
Angola	Ireland	Somalia
Argentina	Israel	South Africa
Australia	Italy	Spain
Azores Islands	Jordan	Sri Lanka
Baharain	Kenya	Sudan
Bangladesh	Kuwait	Swaziland
Botswana	Laos	Sweden
Brunei	Liberia	Switzerland
Cameroon	Madeire	Tanzania
Canary Islands	Malaysia	Thailand
China	Malta	Turkey
Cyprus	Mozambique	Uganda
Denmark	Nepal	UAE
Ethiopia	Netherland	United Kingdom
Faeroe Islands	New Guinea	Uruguay
Fiji	New Zealand	Yemen
Finland	Nigeria	Yugoslavia
Ghana	North Korea	Zambia
Gibraltar	Norway	Zimbabwe
Guinea-Bissan	Oman	
Germany	Pakistan	
Holland	Paraguay	
Hong Kong	Portugal	

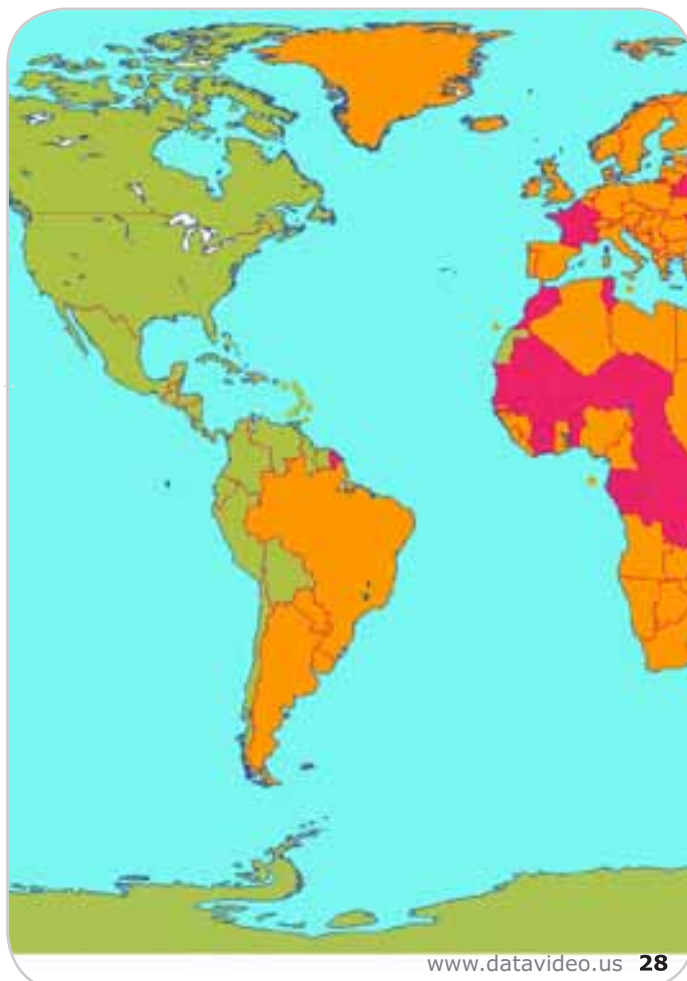



SE-900

Preliminary Product Description

8 VIDEO SOURCE
INPUT SWITCHER
WITH STEREO AUDIO
I/O

A live production switcher for church,
corporate and educational production.

The SE-9Audio inputs. The console portion
fits on a 19" shelf.

PRELIMINARY

Input Video Card Choices

Composite / Component / YC,
DV25
SDI w/wo embedded audio

Audio Inputs

A stereo analog audio input (line level)
will be embedded in the SDI and the DV
stream. The audio may be delayed to
match the DV25 video.

Video Output

SDI, DV25, Component, Y/C (S-Video)
and Composite Video.

Audio Output

Program:
Two analog audio outputs (balanced XLR)
Source:

On each SDI & DV25 input
board there is one unbal-
anced out stereo pair.

Preview Output

Normal is next source pre-
view. Pressing the "PREVIEW" key will
show the next effect.

Tally Output

8 tally low voltage/current contact
closures that can power LED's or solid
state relays.

Character Generator

Designed to work with CG's that use
their own DSK eg: Datavideo CG-100
and Blackmagic Design card.

Remote Control

RS-422 or RS232.

PIP Function

Three fixed sizes, able to move on/off
screen.

Optional Boards

Composite / Component / YC input
DV input
SDI input w/ embedded audio
SDI input w/o embedded audio
Genlock in
Chromakey
SDI out w/ embedded audio
SDI out w/o embedded audio

Character Generator

(a) CG-100 Software and DeckLink Pro card
(b) CG-100 Software, DeckLink Pro card
and 2U Rackmount PC

Estimated Delivery - 2007 1st QTR.



datavideo®

Datavideo U.S.A.

12300 E. Washington Blvd., Ste. U
Whittier, CA 90606 U.S.A.
Tel: (562) 696-2324
Fax: (562) 698-6930
<http://www.datavideo.us>

Datavideo Taiwan

10F, No. 176, Jian-Yi Road, Chung
Ho City, Taipei Hsien 235
Taiwan, R.O.C.
Tel. +886.2.8227.2888
<http://www.datavideo.com.tw>

Datavideo Europe

Californiedreef 26
3565 BL Utrecht
The Netherlands
Tel. +31.30.261.9656
<http://www.datavideo.info>

Datavideo United Kingdom

Unit 2 Waterside Business Park,
Hadfield Glossop, Derbyshire
SK13 1BE United Kingdom
Tel. +44.1457.851000
<http://www.datavideo.info>

Datavideo China

2 F-D, No. 2 Lane 777, West
GuangZhong Road, Zhabei District,
Shang-Hai, China
Tel. +86.21.5603.6599
<http://www.datavideo.cn>

Datavideo Singapore

100 Lor 23, Geylang Road
01-03 D'Centennial
Singapore 388398
Tel. +65.6749.6866
<http://www.datavideo.sg>

Datavideo Office Locations

Datavideo
Taiwan



Datavideo
U.S.A.

Datavideo
U.K.

Datavideo
Europe

Datavideo
China

Datavideo
Singapore

Datavideo
Hong Kong

Demo Datavideo Products in your facility!

No test is better than the one you make in your own facility.
Every Datavideo product is available for a period of up to two weeks for evaluation.
Please check our website <http://www.datavideo.us> for demo information.
Call us at (562) 696-2324 or ask your reseller.

Datavideo U.S.A.

12300 East Washington Blvd., Suite U
Whittier, CA 90606

Tel: +1-562-696-2324
Fax: +1-562-698-6930
<http://www.datavideo.us>

Datavideo United Kingdom

Unit 2 Waterside Business Park,
Hadfield Glossop, Derbyshire
SK13 1BE United Kingdom

Tel: +44-1457-851000
<http://www.datavideo.info>

Datavideo Europe

Californiedreef 26
3565 BL Utrecht
The Netherlands

Tel: +31-30-261-9656
<http://www.datavideo.info>

Datavideo Hong Kong

G/F, 26 CROSS LANE
WANCHAI
HK

Tel: +852-28331981
<http://www.datavideohk.com>

Datavideo China

2 F-D, No. 2 Lane 777, West
GuangZhong Road, Zhabei District,
Shang-Hai, China

Tel: +86-21-5603-6599
<http://www.datavideo.cn>

Datavideo Singapore

100 Lor 23, Geylang Road
01-03 D'Centennial
Singapore 388398

Tel: +65-6749-6866
<http://www.datavideo.sg>

Datavideo Taiwan

10F, No. 176, Jian-Yi Road, Chung
Ho City, Taipei Hsien 235
Taiwan, R.O.C.

Tel: +886-2-8227-2888
<http://www.datavideo.com.tw>

datavideo[®] www.datavideo.us

12300 E. Washington Blvd., Suite U
Whittier, CA 90606 U.S.A.

Tel: +1-562-696-2324 Fax: +1-562-698-6930

Orders & Credit
Marketing & Sales
Technical Support &
Service
Business Hours

contactus@datavideo.us
john@datavideo.us
techsupport@datavideo.us
Mon.- Fri. 9:00a.m. - 5:00p.m.
PACIFIC TIME