



user's manual

Upbeat
model #: BTS100

Portable Bluetooth® Speaker System

hello.

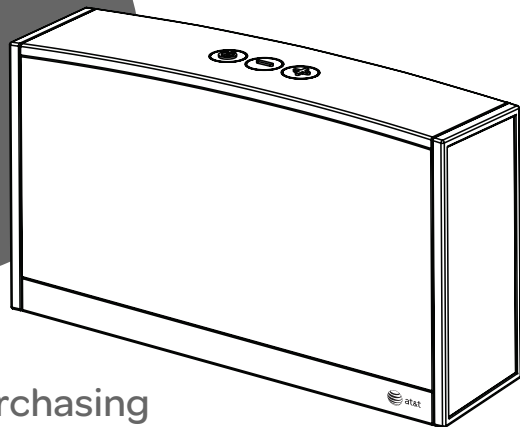

Thank you for purchasing
Upbeat [BTS100].

Portable Bluetooth® Speaker System

Features

- High powered Bluetooth speaker
- Easy pairing Bluetooth 4.0 with stereo A2DP
- APTX compatible (HD stereo)
- Auxiliary input to play music from any device with a headphone jack
- USB charging port to charge your media devices
- Long lasting rechargeable battery

The Bluetooth® word mark and logos are registered trademarks owned by Bluetooth SIG, Inc.

What's Included

Unpack the speaker system and make sure all accessories are put aside so they will not be lost.



AC Adapter

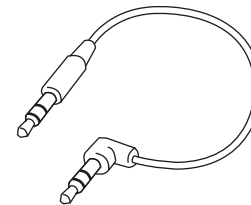

3.5mm Audio Cable

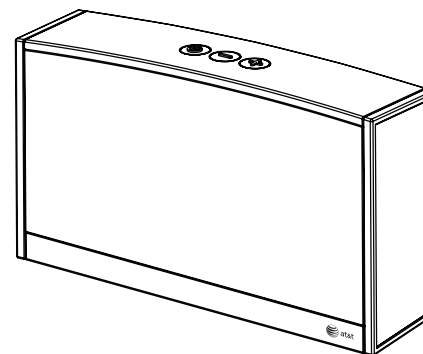

Bluetooth Speaker

Contents

Introduction	2
What's Included	3
Safety Information	5
Getting Started	
Location of Main Unit Controls	8
Power Supply	9
Powering ON/OFF	9
Power Saving Mode	9
Operational Instructions	
Bluetooth Operation	10
Using the Audio Line in Connection	12
Using Upbeat to Charge Your Device	13
Troubleshooting	14
Compliance with FCC Regulations	15
Warranty Information	16
Specifications	18

Safety Information

Warning!

TO REDUCE THE RISK OF FIRE OR ELECTRIC SHOCK, DO NOT EXPOSE THIS APPLIANCE TO DRIPPING OR SPLASHING LIQUIDS.



The lightning flash and arrowhead symbol within the triangle is a warning sign alerting you of “dangerous voltage” inside the product.



WARNING: To reduce the risk of electric shock, do not remove cover (or back). No user-serviceable parts inside. Refer servicing to qualified service personnel.



The exclamation point within the triangle is a warning sign alerting you of important instructions accompanying the product.

NOTES: Caution symbols are printed on rear of unit. Please refer to user's manual. This device complies with Part 15 of the FCC Rules. Operation is subject to the condition that this device does not cause harmful interference.

Safety Information

Important Safety Instructions

When used in the directed manner, this unit has been designed and manufactured to ensure your personal safety. However, improper use can result in potential electrical shock or fire hazards. Please read all safety and operating instructions carefully before installation and use, and keep these instructions handy for future reference. Take special note of all warnings listed in this user's manual and on the unit.

1. **CLEANING** - Unplug the unit from the wall outlet before cleaning. Clean the unit using a damp cloth; do not use liquid or aerosol cleaners.
2. **ATTACHMENTS** - Do not use attachments not recommended by the manufacturer.
3. **WATER AND MOISTURE** - The unit should not be used near water. For example: near a bathtub, washbowl, kitchen sink, laundry tub, swimming pool or in a wet basement.
4. **PLACEMENT** - Do not place the unit on an unstable table, stand, tripod, or bracket. This may result in serious personal injuries and damage to the unit.
5. **VENTILATION** - The unit should be situated so that its location or position does not interfere with its proper ventilation. For example, it should not be situated on a bed, sofa, rug or similar surface that may block ventilation openings. Also, it should not be placed in a built-in installation, such as a bookcase or cabinet, which may impede the flow of air through the ventilation openings.
6. **PERIODS OF NON-USE** - If the unit is to be left unused for an extended period of time, such as a month or longer, the power cable should be unplugged from the unit to prevent damage or corrosion.
7. **OBJECTS AND LIQUID ENTRY** - Care should be taken so that external objects do not fall into and liquids are not spilled onto any openings or vents located on the product.
8. **POWER SOURCE** - The unit should be connected to a power supply only of the type described in the operating instructions or as marked on the unit. If you are not sure, please consult the dealer or local power company.
9. **POWER CORD PROTECTION** - Power supply cord should be routed so that it is not likely to be walked on or pinched by items placed upon or against them. It is always better to have a clear area from where the cable exits the unit to where it is plugged into an AC outlet.

Safety Information

10. **LIGHTNING** - Unplug the unit from the wall outlet and disconnect the antenna or cable system during a lightning storm or when it is left unattended and unused for long periods of time. This will prevent damage to the product due to lightning and power-line surges.
11. **OVERLOADING** - Do not overload wall outlets, extension cords, or integral convenience receptacles as this can result in a risk of fire or electric shock.
12. **HEAT** - The unit should be situated away from heat sources such as radiators, heat registers, stoves or other appliances (including amplifiers) that produce heat.
13. **DAMAGE REQUIRING SERVICE** - The unit should be serviced by qualified service personnel when:
 - A. the power supply cable or plug has been damaged.
 - B. objects have fallen into or liquid has been spilled onto the enclosure.
 - C. the unit has been exposed to rain.
 - D. the unit has been dropped or the enclosure damaged.
 - E. the unit exhibits a marked change in performance or does not operate normally.
14. **SERVICING** - The user should not attempt to service the unit beyond those methods described in the user's manual. Opening or removing covers will expose you to dangerous voltage and other hazards. Service methods not covered in the user's manual should be referred to qualified service personnel.
15. **SAFETY CHECK** - Upon completion of any service or repair to the unit, ask the service technician to perform safety checks to determine that the product is in proper working condition.
16. **BUILT-IN-BATTERY CARE** - This device contains a rechargeable Lithium ion battery. The battery can be charged and discharged hundreds of times. Unplug the charger from the electrical outlet and product when not in use. Do not leave a fully charged battery connected to a charger, since overcharging may shorten its lifetime. Leaving the product in hot or cold places will reduce the capacity and lifetime of the battery.

Getting Started

Location of Main Unit Controls

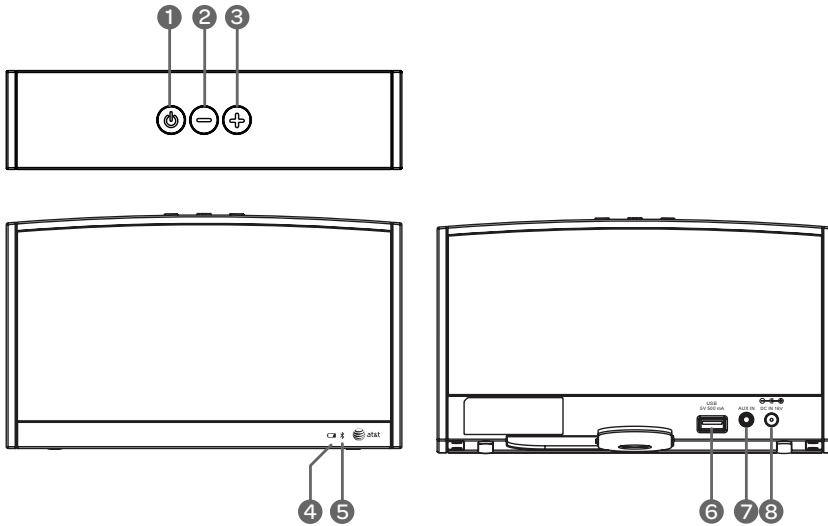

1. ⏻ POWER ON/OFF/PLAY/PAUSE Button
2. VOLUME - Button
3. VOLUME + Button
4. Battery LED Indicator
5. Bluetooth LED Indicator
6. USB Port
7. AUX IN Jack
8. DC IN Jack

Getting Started

Power Supply

Charging Upbeat

1. Connect the supplied AC adapter to the back of Upbeat.
2. Plug the supplied AC adapter into a wall power outlet to begin charging Upbeat's internal battery.
3. The battery LED indicator light will turn orange while charging and will turn green when the battery is fully charged.

Note: Full charge time is approx 4 hours.

LED Status Indicator

- Bluetooth LED Indicator
 - Blinking Blue LED: Bluetooth on with no connection. (Ready to pair)
 - Solid Blue LED: Bluetooth paired and connected
- Battery LED Indicator
 - Orange LED: Charging (When plugged into a wall outlet)
 - Green LED: Fully charged (When plugged into a wall outlet)
 - Red LED: Low battery (When running on the built-in battery)

Powering ON/OFF

- To power the speaker on, press and hold the ⏻ button for 3 seconds until you hear an ascending audible tone and the Bluetooth LED light starts blinking.
- To power the speaker off, press and hold the ⏻ button for 3 seconds until you hear a descending audible tone. The Bluetooth LED will shut off.

Power Saving Mode

The Upbeat will automatically enter power saving mode if no audio is played for 30 minutes. Press and hold power button 3 seconds to wake the speaker up.

Operational Instructions

Bluetooth Operation

Bluetooth Device Compatibility

Upbeat connects with most Bluetooth devices that support the A2DP profile, including iPad®/iPhone®/iPod® touch devices, and most smartphones, laptops and tablets.

Setting Up Your Upbeat for Pairing

1. Power on the Upbeat speaker.
2. The blue LED light will start to flash, indicating that Upbeat is now ready to be paired with your Bluetooth device.

Pairing a Bluetooth Device for the First Time

1. Navigate to the Bluetooth manager on your Bluetooth device.
2. Search Bluetooth devices and select 'Upbeat' to start connecting.
3. Once paired, Upbeat will beep and the Bluetooth LED light will turn solid blue.
4. Your Bluetooth device is now paired, connected and ready to stream audio to the speaker system.
5. Although Upbeat can only stream audio from one device at a time, it is capable of being paired with multiple devices.

Note: If your device asks for a PIN code, enter "0000".

Connecting a Paired Bluetooth Device

1. You will only need to pair your Bluetooth device with Upbeat one time.
2. The next time your Bluetooth device and Upbeat are in range of each other, and the Bluetooth feature is turned on, they will automatically connect.
3. The speaker system will only automatically connect to the last Bluetooth device it was connected to.
4. If your paired device does not automatically connect, navigate to the Bluetooth menu on your device and select Upbeat from the list.

iPad, iPhone and iPod are registered trademarks of Apple Inc.

Operational Instructions

Playing Audio from Your Bluetooth Device

1. Once your Bluetooth device is connected to Upbeat, simply start playing your music, movie or game and all audio will automatically be played through Upbeat.
2. Press **⏮** to play/pause the audio.
3. Press + or - to adjust the volume level of the audio.
4. Keep in mind that Upbeat has up to a 30-foot Bluetooth wireless range.

Note: The volume controls on your media device work separately from the volume controls on Upbeat.

Disconnect your Bluetooth device

To disconnect your Bluetooth device from the speaker, turn off the Bluetooth feature of your connected device or press + and - at the same time. The Bluetooth LED indicator will start to flash.

Reconnecting Your Device

If you move out of range or turn off the Bluetooth feature on your device, the speaker system will disconnect from your device. To reconnect, simply access the Bluetooth Manager on your device and select Upbeat. You will not be asked to enter the PIN code again.

Out of Range or Lost Signal

If the music device is out of range of Upbeat or if there is something blocking the Bluetooth signal, the Bluetooth LED light will flash to indicate that the Bluetooth connection with Upbeat has been lost.

To avoid a lost connection:

1. Move the music device back into range, and/or make sure there's a clear line of sight between Upbeat and the Bluetooth device.
2. If the connection is lost, the connection will need to be reestablished. Follow the directions under "Reconnecting Your Device".

Operational Instructions

Using the Audio Line in Connection (aux-input)

You can connect the audio output of an external device, such as a MP3 player or smartphone, to Upbeat for listening to the audio of that device through the high quality amplifier of the speaker system.

- Use a standard stereo headphone (3.5 mm) cable to connect the "headphone-out" or "audio line-out" of the device to the aux-in jack of this speaker system.
- Turn on the speaker system and the external device (eg. MP3-player or smartphone).
- Make sure the speaker system is not connected to any Bluetooth devices.
- Start playback of the external device and adjust the volume of the docking station to the desired level.
- Remember to switch off the speaker system when you are finished using the external device.

Note: The volume controls on your media device work separately from the volume controls on Upbeat.

Operational Instructions

Using Upbeat to Charge Your Device

Upbeat includes a USB port on the back to allow you to charge your media device. Plug Upbeat into a wall outlet and then connect your device to the speaker using a USB cable (not included).

Note: Power output of the USB port is 500 mA. Media devices that require more power may not charge through this USB port.

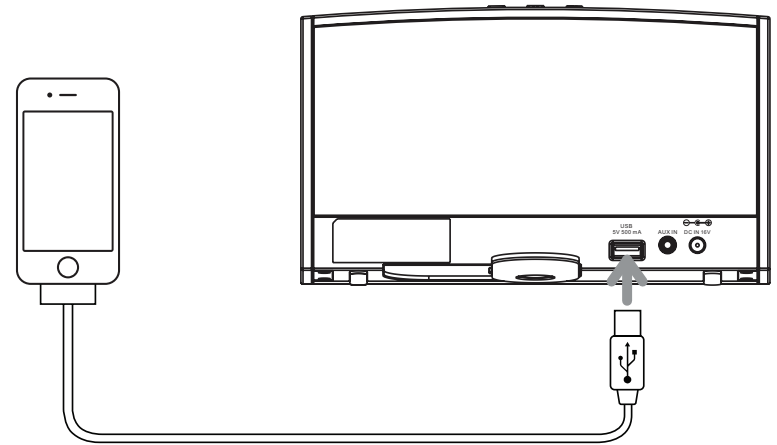

Troubleshooting

Symptom	Solution
Music is not streaming over Bluetooth	<ul style="list-style-type: none">- Make sure your Bluetooth device has A2DP profile.- Check if both devices are paired and connected over Bluetooth.- Make sure there isn't a 3.5mm cable connected to the aux input on the back of the speaker.- Restart the BTS100 to auto-connect with your Bluetooth device.
No power	<ul style="list-style-type: none">- Verify BTS100 is plugged in properly and into a proper power source.
Battery is not charging	<ul style="list-style-type: none">- Verify BTS100 is plugged in properly and into a proper power source.
My mobile device is not charging when connected to the USB port on the BTS100	<ul style="list-style-type: none">- Make sure the BTS100 is plugged into a wall outlet. The USB port will not charge your mobile device unless the BTS100 is plugged in.
	<ul style="list-style-type: none">- The built in USB port supports up to 500mA output power. Some larger devices (ie tablets) may require more output power in order to charge.

Remarks:

If troubleshooting does not eliminate the problem, disconnect the DC IN plug from the back of unit and reconnect it after a few seconds. This resets the unit to its factory default settings and results in the deletion of all previous settings. In case the problem still exists, see warranty information on pages 16 and 17 to obtain service.

Compliance with FCC Regulations

Caution!

The user is cautioned that changes or modifications not expressly approved by the party responsible for compliance could void the user's authority to operate the equipment.

The equipment has been tested and found to comply with the limits for a Class B digital device, pursuant to Part 15 of the FCC Rules. These limits are designed to provide reasonable protection against harmful interference in a residential installation. This equipment generates, uses, and can radiate Radio frequency energy and, if not installed and used in accordance with the instructions, may cause harmful interference to Radio communications.

However, there is no guarantee that interference will not occur in a particular installation. If this equipment does cause harmful interference to Radio or television reception, which can be determined by turning the equipment off and on, the user is encouraged to try to correct the interference by one or more of the following measures:

- Reorient or relocate the receiving antenna.
- Increase the separation between the equipment and receiver.
- Connect the equipment into an outlet on a circuit different from that to which the receiver is connected.
- Consult the dealer or an experienced Radio/television technician for assistance.

This equipment complies with FCC's RF radiation exposure limits set forth for an uncontrolled environment. The antenna(s) used for this transmitter must be installed and operated to provide a separation distance of at least 20 cm from all persons and must not be collocated or operating in conjunction with any other antenna or transmitter. Installers must ensure that 20 cm separation distance will be maintained between the device (excluding its handset) and users.

THE SPECIFICATION AND EXTERNAL APPEARANCE OF THE SPEAKER SYSTEM ARE SUBJECT TO CHANGE WITHOUT PRIOR NOTICE.



If at any time in the future you should need to dispose of this product, please note that waste electrical products should not be disposed of with household waste. Please recycle where facilities exist. Check with your local authority or retailer for recycling advice.

Warranty Information

Limited Warranty

The AT&T brands are used under license. Any repair, replacement, or warranty service, and all questions about this product should be directed to Concept 101 LLC at www.att.com/electronics or call 1 (888) 920-8680 from the USA or Canada.

Concept 101 LLC warrants to the original purchaser that the product will be free from defects in material, parts and workmanship for the period designated for this product. The warranty commences the day the product is purchased and covers up to a period of one (1) year (90 day Labor and 1 year Parts). Concept 101 LLC agrees that it will, at its option, replace the defective product with either a new or remanufactured docking station equivalent to your original purchase during the warranty period. Should the Parts warranty period exceed the Labor warranty period, Concept 101 LLC will supply at no charge for the remainder of the Parts warranty, any new or remanufactured replacement parts as required by the product. During this period all labor and service charges will become the responsibility of the customer.

Exclusions: This warranty does not apply to the appearance or exterior of the product which may have been damaged or defaced, altered or modified in design or construction. This warranty does not apply if the serial number is altered or removed, or if there is any damage due to power line surge, user damage to the AC power cord, connection to improper voltage source, general misuse, accidents, or repair attempts by unauthorized service agents. Other exclusions include ear pads, rechargeable and non-rechargeable batteries.

REPAIR OR REPLACEMENT AS PROVIDED UNDER THIS WARRANTY IS THE EXCLUSIVE REMEDY OF THE CUSTOMER; Concept 101 LLC SHALL NOT BE LIABLE FOR ANY INCIDENTAL OR CONSEQUENTIAL DAMAGES FOR BREACH OF ANY EXPRESS OR IMPLIED WARRANTY ON THIS PRODUCT, EXCEPT TO THE EXTENT PROHIBITED BY APPLICABLE LAW. ANY IMPLIED WARRANTY OF MERCHANTABILITY OF FITNESS FOR A PARTICULAR PURPOSE ON THIS PRODUCT IS LIMITED TO THE DURATION OF THE WARRANTY.

Warranty Information

Some states do not allow the exclusion or limitations of incidental or consequential damages, or limitations on how long the warranty lasts. In these cases the above exclusions or limitations may not apply to you. This warranty gives you specific legal rights and you may also have other rights which vary from state to state.

Obtaining Service: To obtain service, product literature, supplies or accessories please call 1888-920-8680, or visit our website, www.att.com/electronics, to create a ticket for exchange/repair. Please make sure to provide the date of purchase, model number and a brief description of the problem. Our customer service representative will contact you or send detailed return instructions.

Concept 101 LLC does not warrant that the docking station will work properly in all environmental conditions, and makes no warranty and representation, either implied or expressed, with respect to the quality, performance, merchantability, or fitness for a particular purpose other than the purpose identified within this user's manual. Concept 101 LLC has made every effort to ensure that this user's manual is accurate, and disclaims liability for any inaccuracies or omissions that may have occurred. Information in this user's manual is subject to change without notice and does not represent a commitment on the part of Concept 101 LLC. Concept 101 LLC reserves the right to make improvements to this user's manual and/or to the products described in this user's manual, at any time without notice. If you find information in this manual that is incorrect, misleading, or incomplete, please contact us through our website.

Specifications

- Power supply: DC 16V, 1.8Amps through built-in DC jack
External AC power adapter 100V-240V ~ 50/60Hz
- Speaker: Impedance 8 Ω 2.0" Speaker x2
- Bluetooth version 4.0
- Bluetooth compatibility: Bluetooth 2.0 or above device with A2DP/AVRCP



www.att.com/electronics

purchase date:

place of purchase: