



IRIDIUM

9522A L-Band Transceiver Product Information Guide Revision 1.01



Iridium Satellite LLC
6701 Democracy Blvd., Suite 500
Bethesda, MD 20817 USA
www.iridium.com

Toll Free: +1.866.947.4348 [US Only]
International +1.480.752.5155
email: info@iridium.com

Contents

Revision History.....	2
1.0 Product Overview	3
2.0 Standards Compliance	3
2.1 FCC Compliance	3
2.2 CE Compliance	3
3.0 Physical Specifications	4
3.1 Environmental	4
3.2 Dimensions.....	4
3.3 Interface Connectors.....	6
3.3.1 Multi-Interface Connector	6
3.3.2 Antenna Connector.....	7
3.3.3 SIM Chip Reader	7
3.4 Mounting.....	7
3.5 Connector Sealing in Harsh Environments	7
4.0 Electrical Interfaces	8
4.1 DC Power Interface.....	8
4.1.1 DC Power Interface Signal Descriptions	8
4.1.2 DC Power Input Specifications.....	8
4.2 Control/Digital Audio (DPL bus) Interface	8
4.2.1 Control/Digital Audio Interface Signal Descriptions.....	8
4.3 RS232 Data Interface.....	9
4.3.1 RS232 Data Signal Descriptions	9
4.3.2 Autobaud	9
4.4 Analog Audio Interface.....	9
4.4.1 Analog Audio Interface Signal Descriptions	9
4.5 SIM Interface.....	9
4.6 RF Interface.....	10
4.6.1 RF Interface Specifications	10
4.6.2 Radio Characteristics	10
5.0 Instructions for the safe Installation and use of the 9522A LBT.....	11
5.1 Instructions for the Integrator.....	11
5.2 Instructions from the integrator to the user	11
6.0 Modem Commands and Configuration.....	11

Revision History

Revision	Date	Comment
V1.0	02 14 2005	First revision
V1.01	03 24 2005	Revised upper range of operating temperature specification in Section 3.1

Export Compliance Information

This product is controlled by the export laws and regulations of the United States of America. The U.S. Government may restrict the export or re-export of this product to certain individuals and/or destinations. For further information, contact the U.S. Department of Commerce, Bureau of Industry and Security or visit www.bis.doc.gov.

1.0 Product Overview

The 9522A L-Band Transceiver (LBT) is designed to be integrated into a specific application with other hardware and software to produce a solution designed for a specific application or vertical market. Some examples of these solutions include a maritime voice telephony terminal or a vehicle tracking solution.

The LBT functionally supports all of Iridium's voice and data services. Applications can be built to use one or multiple services using the voice and data interfaces. The 9522A is a functional replacement to the 9522 "Sebring" LBT. However it should be noted that there are some differences to the voice interface.

The 9522A is regulatory approved for FCC, Canada, and CE assuming an antenna with a gain of ~3 dBi. This allows the LBT to be integrated into a variety of subscriber products, or retrofitted into existing LBT-based products. These products, when integrated together will require regulatory testing to be conducted by the integrator.

The LBT is essentially provided as a 'black box' with all interfaces provided via a DB25 connector. The product provides the core transceiver module and SIM card reader. All other functions and hardware such as keypad, display, power supply, antenna etc. must be provided by the solution developer. The DB25 provides the following interfaces and connections:

- Analog Audio
- Control / Digital Audio
- RS232
- Power Input
- On / Off

2.0 Standards Compliance

The 9522A is designed to comply with the standards for Radio Emissions Compliance, Electromagnetic Compatibility, and AC Safety in the United States, European Union and Canada.

2.1 *FCC Compliance*

The 9522A is certified under 47 CFR Part 25 as FCC ID:Q639522A. It also complies with Part 15 of the FCC Regulations. Operation is subject to the condition that this device does not cause harmful interference. Any changes or modifications, including the use of a non-standard antenna, not expressly approved by the party responsible for compliance could void the user's authority to operate the equipment.

IMPORTANT: To comply with FCC RF exposure requirements, a minimum separation of 20 cm is required between the antenna and all persons.

2.2 *CE Compliance*

This product, when marked with the CE symbol, complies with the European Community Council Directive for R&TTE, 99/5/EC, provided that the integrator/user adheres to the instructions detailed in this LBT Interface Specification. This product is in compliance with applicable ETSI standards. Compliance with the requirements of ETSI EN 301 489 requires the use of a shielded digital data interface cable.

3.0 Physical Specifications

The 9522A is depicted in Figure 1 below.

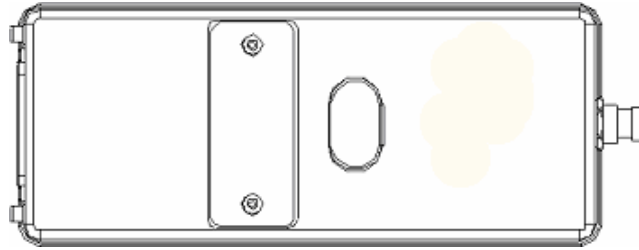

Figure 1: Top View of 9522A

3.1 Environmental

The environmental specifications of the 9522A LBT are summarized in Table 1 below.

Table 1: Environmental Specifications

Parameter	Value
Operating Temperature Range	-20°C to + 60°C
Operating Humidity Range	≤ 75% RH
Storage Temperature Range	-40°C to + 85°C
Storage Humidity Range	≤ 93% RH

3.2 Dimensions

The overall dimensions of the 9522A LBT and its weight are summarized in Table 2 below. Dimensioned views of the 9522A LBT are shown in Figures 2-5 which follow.

Table 2: Mechanical Dimensions

Parameter	Value
Length (including antenna connector)	216.1 mm (8.51")
Length (excluding antenna connector)	196.4 mm (7.73")
Width	82.6 mm (3.25")
Depth	39.0 mm (1.54")
Weight (approximate)	659 g

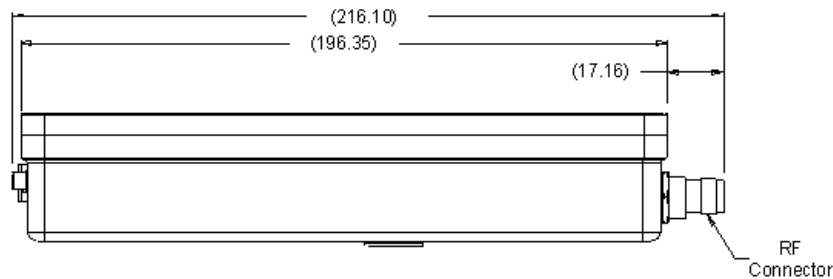

Figure 2: Side View

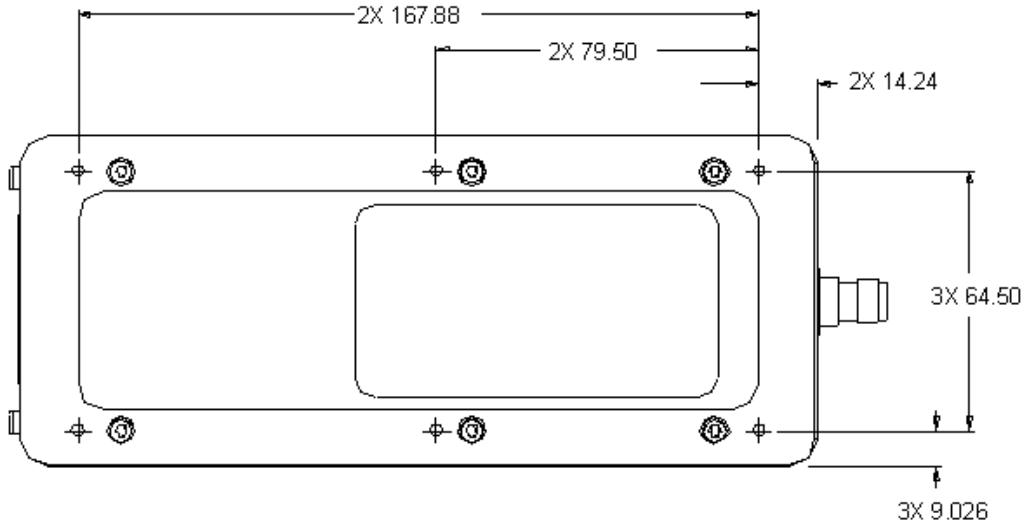

Figure 3: Bottom View

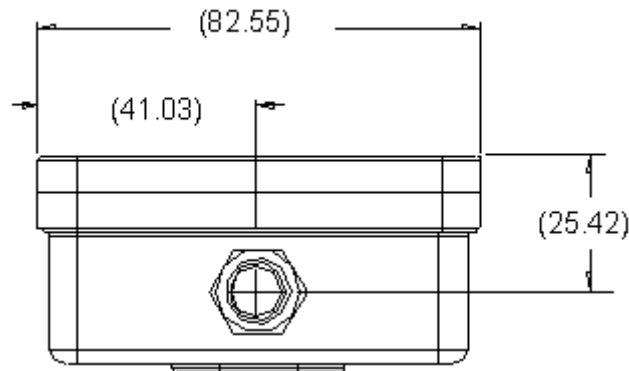

Figure 4: Antenna Connector End View

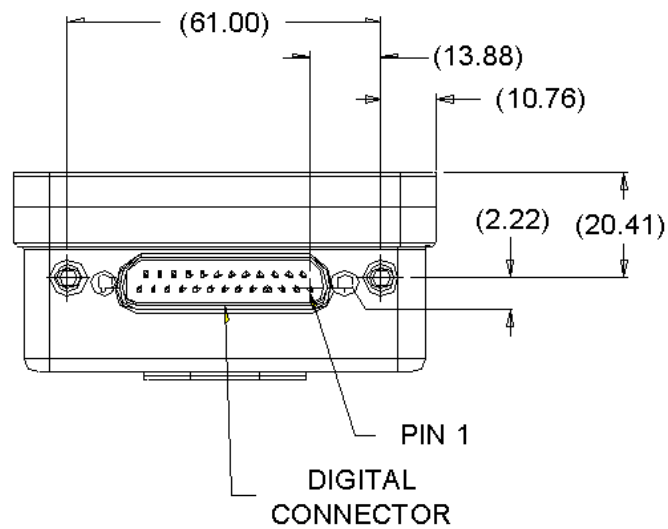

Figure 5: Multi-Interface Connector End View

3.3 Interface Connectors

The 9522A LBT incorporates three interface connectors:

- Multi-Interface Connector (located on the end of the 9522A LBT)
- Antenna Connector (located on the end of the 9522A LBT; opposite to the multi-interface connector)
- Subscriber Identity Module (SIM) Chip Connector (located beneath a cover plate atop the 9522A LBT)

3.3.1 Multi-Interface Connector

The multi-interface connector is a 25 pin D-subminiature type that includes four interfaces:

- DC Power
- Control/Digital Audio (DPL bus)
- RS232 Data
- Analog Audio

The pin out information for this connector is given in Table 3 below.

Table 3: 25-way connector pin-out

Contact	Signal	Description
1	EXT_ON_OFF	External connection for On / Off key input to Daytona LBT
2	EXT_11HZ	90ms "frame sync" signal (used in testing)
3	EXT_GND	Power Ground input to Daytona LBT
4	EXT_PWR	Power input to Daytona LBT
5	SPKR_AUD	Speaker audio output from Daytona LBT
6	DA_TX	PCM digital audio output from Daytona LBT
7	DF_RI	Data / Fax Ring Indication output from Daytona LBT
8	DF_RTS	Data / Fax Request to Send input to Daytona LBT
9	DF_S_TX	Data / Fax (UART) data input to Daytona LBT
10	DF_DCD	Data / Fax Data Carrier Detect output from Daytona LBT
11	DA_FS	PCM digital audio frame sync output from Daytona LBT
12	DA_CLK	PCM digital 2.048MHz audio clock output from Daytona LBT
13	DF_S_RX	Data / Fax data (UART) output from Daytona LBT
14	0V	Signal ground, 0V signal reference and return
15	MIC_AUD	Microphone audio input to Daytona LBT
16	EXT_PWR	Power input to Daytona LBT
17	EXT_GND	Power Ground input to Daytona LBT
18	DPL_TX	Digital Peripheral Link (UART) data output from Daytona LBT
19	DF_DTR	Data / Fax Data Terminal Ready input to Daytona LBT
20	DPL_RX	Digital Peripheral Link (UART) data input to Daytona LBT
21	DF_DSR	Data / Fax Data Set Ready output from Daytona LBT
22	DF_CTS	Data / Fax Clear to Send output from Daytona LBT
23	0V	Signal ground, 0V signal reference and return
24	DA_RX	PCM digital audio input to Daytona LBT
25	0V	Signal ground, 0V signal reference and return

3.3.2 Antenna Connector

The 9522A LBT provides a single 50 Ω , TNC type antenna connector both transmit and receive.

3.3.3 SIM Chip Reader

An integrated SIM chip reader is provided on the 9522A LBT. This connector allows installation of the chip form of the SIM beneath a cover plate on the 9522A LBT housing.

3.4 Mounting

The 9522A LBT incorporates (6) mounting holes on its bottom surface that can aid in its mounting. See Figure 3 for locations of these features. It is recommended that a thread-forming screw be used to mount the 9522A LBT via these features. Particularly, a Textron Camcar® Taptite® II Thread-Rolling Fastener of M3.5x0.6 thread type is recommended. This fastener has a 15IP Torx Plus® pan head and is available in lengths of 6, 8, 12, 16, and 20 mm as part number 3BE-P802-00, 3BE-P803-00, 3BE-P8185-00, 3BE-P804-00, 3BEP8186-00, and 3BE-P8187-00 respectively. Length should be chosen to ensure that penetration into the 9522A LBT housing does not exceed 11 mm. If a 6-32 thread type is desired, a Textron Camcar® Taptite® II Thread-Rolling Fastener with a 15IP Torx Plus® pan head is available in lengths of 1/4, 5/16, 3/8, 1/2, 5/8, 3/4, and 1 inch as part number 3BE-P814-00, 3BE-P8123-00, 3BE-P815-00, 3BE-P816-00, 3BE-P8124-00, 3BE-P817-00, and 3BE-P818-00 respectively. A 10IP Torx Plus® flat head version is also available in a single length of 1/2 inch as part number 3BE-P801-00. Another 6-32 thread type option is to insert a helical coil insert with a 6-32 internal thread into these features thus accommodating 6-32 threaded fasteners as mounting hardware for the 9522A LBT. National Aerospace Standard NASM122238 serves as a technical reference for the recommended helical coil insert.

3.5 Connector Sealing in Harsh Environments

If the 9522A LBT is to be used in a harsh environment with exposure to high humidity or water, the mating of the multi-interface connector must be further sealed to protect from moisture entry. It is recommended that a bead of RTV silicone sealant be placed on the connector mating to the 9522A LBT's multi-interface connector where shown in Figure 6 below. A material similar to Permatex 16B should be used.

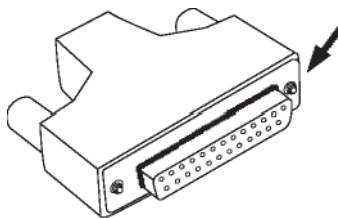

Figure 6: Placement of Silicone RTV bead around the connector mating to the 9522A's multi-interface connector.

4.0 Electrical Interfaces

The subsections to follow contain interface information for the electrical interfaces of the 9522A LBT.

4.1 DC Power Interface

4.1.1 DC Power Interface Signal Descriptions

The DC power interface is comprised of the DC power inputs and a control signal as summarized in Table 4 below. The EXT_PWR and GND inputs are used to supply DC power to the 9522A LBT. The EXT_ON_OFF control input is pulled to a GND level to toggle the 9522A LBT on and off. Note that both pairs of pins should be connected for EXT PWR and EXT GND.

Table 4: Control/Audio Interface Signal Descriptions

Signal Name	Signal Description
EXT_PWR (pin 4 and 16)	External power +4.4VDC input
EXT_GND (pin 3 and 17)	External power GND input
EXT_ON_OFF (pin 1)	Power on/off control input

4.1.2 DC Power Input Specifications

The DC power requirements for the 9522A LBT are summarized in Table 5 below. Note that these requirements apply to DC power measured at the 9522A LBT multi-interface connector input.

Table 5: DC Power Input Specifications

Parameter	Value
Main Input Voltage Range	+4.0 VDC to +4.8 VDC
Main Input Voltage - Nominal	4.4VDC
Main Input Voltage – Ripple	40 mV peak to peak
Consumption at +4.4 VDC	
	Value
Input Standby Power (average)	570mW
Peak Transient Current – Transmit	2.5A
Current Average – Continuous Transmit at Maximum RF Power (see note)	1.0A
Power Average – Voice/Data Call (see note)	2200mW

Note: The average power consumption depends on the view of the satellite constellation from the antenna.

4.2 Control/Digital Audio (DPL bus) Interface

4.2.1 Control/Digital Audio Interface Signal Descriptions

The control/digital audio interface enables peripherals such as handsets and SIM card readers to be interfaced to the 9522A LBT. The interface utilizes an Iridium Proprietary communication bus not detailed in this fact sheet. Details can be made available after appropriate Non-Disclosure and/or License Agreements are executed.

4.3 RS232 Data Interface

4.3.1 RS232 Data Signal Descriptions

The RS232 data interface is comprised of eight standard RS232 data, control, and status signals plus a ground level signal reference. This interface allows a connected Data Terminal Equipment (DTE) to utilize the 9522A LBT's modem functionality via AT command control. A 3-wire RS232 Data minimal interface may also be implemented however the 9 wire interface offers better control and is the recommended implementation.

4.3.2 Autobaud

Autobaud is enabled by default. Autobaud will occur on the following characters 'a', 'A', or CR (carriage return). Autobaud will also occur on the escape sequence character, provided this is an odd number character. Normally this is set to '+' in register S2. See the AT Command Reference for details.

4.4 Analog Audio Interface

4.4.1 Analog Audio Interface Signal Descriptions

The analog audio interface is comprised of the analog audio input and output signals referenced to the 0V signal ground as summarized in Table 6 below.

Table 6: Analog Audio Interface Signal Descriptions

Signal Name	Signal Description
MIC_AUD (pin 15)	Analog audio input to LBT
SPKR_AUD (pin 5)	Analog audio output from LBT
0V (pins 14, 23 and 25)	Signal ground

4.5 SIM Interface

An integrated SIM chip reader is provided on the 9522A LBT. An external SIM card reader may also be interfaced as a peripheral to the 9522A LBT via the DPL bus (control/audio interface). A SIM card in the external reader will take precedence over the SIM chip in the integrated connector when both are present.

4.6 RF Interface

4.6.1 RF Interface Specifications

The RF interface requirements for the 9522A LBT are summarized in Table 7 below.

Table 7: General RF Parameters

Parameter	Value
Frequency Range	1616 MHz to 1626.5 MHz
Duplexing Method	TDD (Time Domain Duplex)
Oscillator Stability	± 1.5 ppm
Input/Output Impedance	50Ω
Multiplexing Method	TDMA/FDMA

4.6.2 Radio Characteristics

The tables within this section contain radio characteristics of the 9522A LBT.

Table 8: In-Band Characteristics

Parameter	Value
Average Power during a transmit slot (max)	7 W
Average Power during a frame (typical)	0.6 W
Receiver Sensitivity at 50W (typical)	-118.5 dBm
Receiver Spurious Rejection at offsets > 1 MHz (typical)	60 dB

Table 9: Link Margin

Configuration	Cable Loss	Link Margin
9522A LBT with accessory antennas (Note 1)	2 dB (Note 2)	13.1 dB (Note 3)

Note 1: Other antenna options are available

Note 2: Cable losses should be minimized

Note 3: Link Margin given for free space

5.0 Instructions for the safe Installation and use of the 9522A LBT

The 9522A LBT is intended for integration into a finished product. The integrator of the 9522A LBT is required to connect a power supply, antenna, and user interface to the 9522A LBT. To ensure that the 9522A LBT is correctly installed the following general instructions (sub-section 5.1) are provided for the installer.

The integrator will be required to supply the end user of the integrated product, incorporating the 9522A LBT, with operating instructions and any other information relating to the maintenance and safety of the equipment (sub-section 5.2).

5.1 *Instructions for the Integrator*

- The 9522A LBT must be installed by an appropriately qualified installer and mounted securely as described in section 3.4 of this document.
- The power supply used to power the 9522A LBT must be checked to ensure it meets the requirements of sub-section 4.1.2 of this document.
- Electrical connections to the 9522A LBT multi-interface connector shall be as designated in Table 3 of sub-section 3.3.1 of this document.
- The current and voltage rating of the multi-interface connector cable shall meet the requirements of the LBT DC power input.
- The electrical characteristics of the multi-interface connector cable shall not degrade the 9522A LBT digital communications and analog audio signals.
- The multi-interface connector cable will provide adequate screening from external electromagnetic interference.
- The 9522A LBT shall not be located in close proximity to sources of extreme temperature which will cause it to be operated outside of its temperature specification.
- The 9522A LBT shall not be operated without an appropriate antenna connected to its Antenna connector via a suitable 50 Ohm coaxial cable. This antenna shall be sited at least 20cm away from any person.

5.2 *Instructions from the integrator to the user*

To comply with the requirements of sub-clause 1.7.2 (Safety instructions) of the European Information technology equipment safety standard EN60950-1:2002 the integrator must ensure that:

'Sufficient information shall be provided to the USER concerning any condition necessary to ensure that, when used as prescribed by the manufacturer, the equipment is unlikely to present a hazard within the meaning of this standard. If it is necessary to take special precautions to avoid the introduction of hazards when operating, installing, servicing, transporting or storing equipment, the necessary instructions shall be made available.'

As part of these instructions the installer should inform the user that they should not service the 9522A LBT.

6.0 Modem Commands and Configuration

The 9522A is configured through the use of AT commands. A full listing of the supported AT commands can be found in the AT Command Reference document.