

# Daytime Fan-Aspirated Radiation Shield Kit Installation Manual

For Vantage Pro2™ & Vantage Pro2 Plus™ Stations

---

## Introduction

The instructions describe how to upgrade a non-aspirated Vantage Pro2™ radiation shield to a Daytime Fan-Aspirated Radiation Shield.

The upgrade kit can be installed on any Vantage Pro2™ or Vantage Pro2 Plus™ Integrated Sensor Suite (ISS) equipped with a non-aspirated radiation shield.

## Components

The upgrade kit includes the following components:

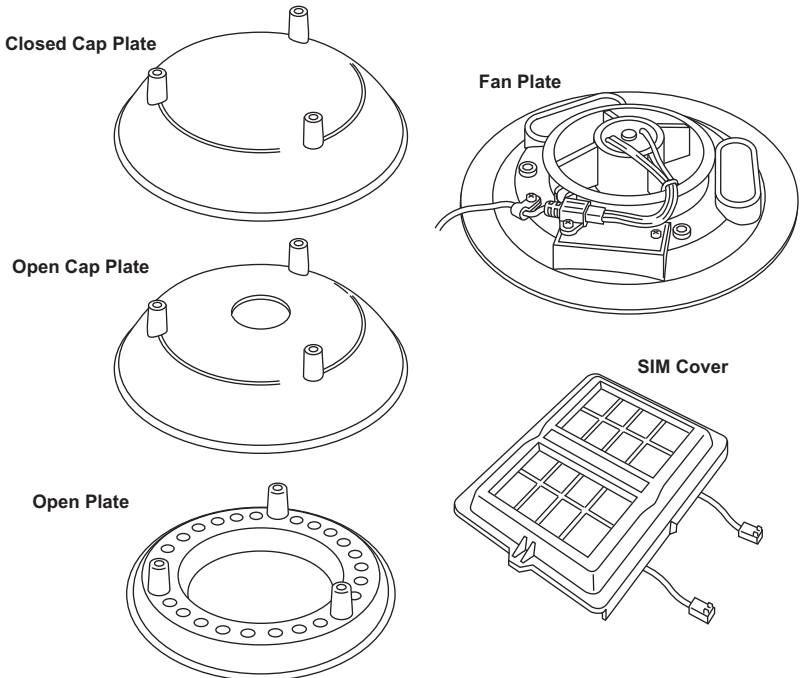

*Daytime Fan Kit Components*

The kit also includes the following hardware:

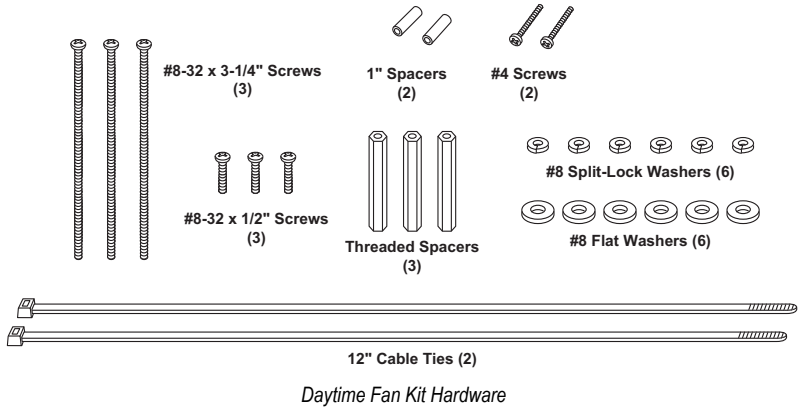

### Tools Needed

You may need some or all of the following tools to complete the upgrade:

- A medium Phillips-Head screwdriver
- A medium slot-tip screwdriver
- Other tools as required to remove and re-mount the ISS
- **Cabled ISS Only:** Wire cutters

## Installing the Daytime Fan Kit

### Installation Overview

These are the steps to install the Daytime Fan components:

1. **For Consoles Only** — Put the console into Setup Mode.
2. Take the ISS down from its installed position.
3. Disassemble the standard radiation shield.
4. Check Temperature/Humidity sensor orientation.
5. Assemble the lower section of the fan-aspirated shield.
6. Install the fan unit.
7. Assemble the upper section of the fan-aspirated shield.
8. Re-Install the ISS.
9. Take the console out of Setup Mode.

### For Consoles Only— Put Console in Setup Mode

If you have a console, you need to put it in Setup Mode. This prevents the reception of erroneous data while you are removing the ISS.

If you have an Envoy and are concerned with erroneous data, you may edit the data via the WeatherLink software. See the WeatherLink Online Help for more information.

To put your console in Setup Mode:

At your Vantage Pro2 console, press and hold DONE and then press the down arrow (-) to put the console in Setup Mode. This prevents the reception of erroneous data while you are removing the ISS.

**Note:** If the console acquires erroneous data during the upgrade, see *Take the Console Out of Setup Mode* on page 15 for instructions on clearing data. Additional information on clearing console data can be found in the *Vantage Pro2 Console Manual*.

## Take Down the ISS

Please work on your Vantage Pro2 ISS in a safe place. If you are installing the Daytime Fan Kit on an ISS that has already been placed into service, you will need to take down the ISS from its sited location and move it to a convenient and safe place to perform the installation.

To disassemble the ISS:

1. Locate the Sensor Interface Module (SIM) housing cover on the side of ISS and open it.
2. Disconnect the Solar Panel wire on the SIM cover from the SIM board by pulling the Solar Panel connector.
3. Pull the foam insert out of the cable access port in between the cables and set the foam insert aside.
4. Disconnect the anemometer cable from the sensor connector labeled WIND and, if you are using a cabled model, disconnect the console cable from the SIM and slide the cables out of the cable access port.
5. You can now remove the ISS from its mounted position. Move it to a safe place to install the kit components.

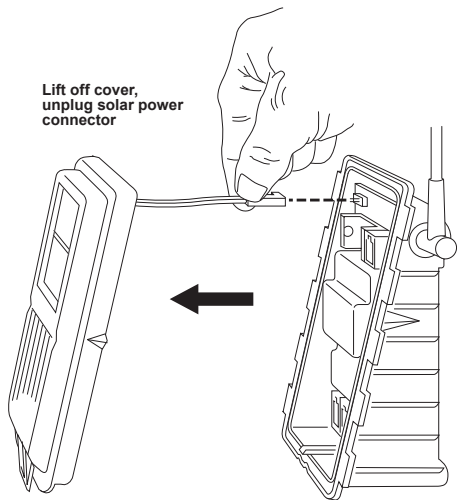

*Detaching the SIM Cover*

## Disassemble the Standard Radiation Shield

**Note:** We recommend using a workbench or table to perform the following procedures.

1. Open and remove the SIM cover if you have not done so already.
2. Disconnect the Temperature/Humidity cable from the SIM and slide the cable out of the cable access port.

3. Remove the rain collector cone from the ISS base by rotating the cone counter-clockwise. When the cone's latches line up with openings in the base, you can lift the cone off. The cone fits in the base tightly and may require extra pressure to remove the first few times. Steady the ISS base between your knees when removing the cone

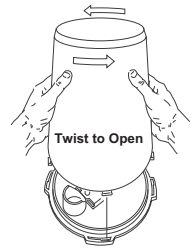

Remove the Rain Collector Cone

4. Remove the three 8-32 x 4" screws holding the radiation shield plates together.
5. Save these three screws and washers, and separate out the radiation plating.

Depending on the placement of the Temperature/Humidity sensor, you may need to reorient the sensor before assembling the lower section of the radiation plating. See Check Temperature/Humidity Sensor Orientation on page 5 for more information.

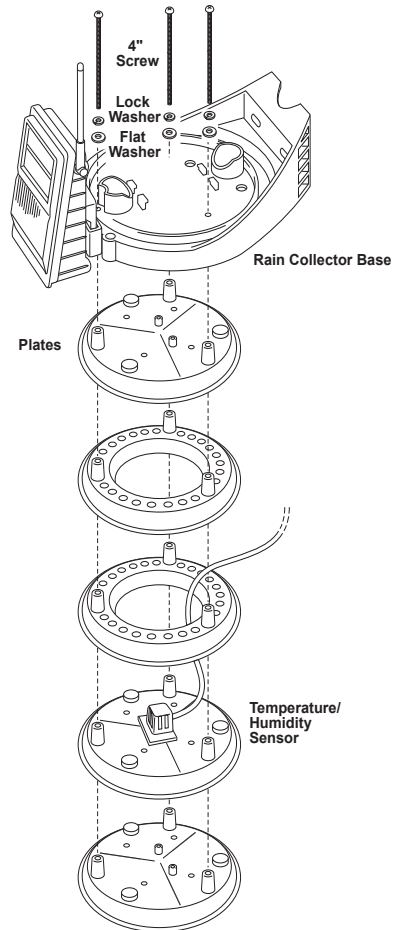

Standard Radiation Shield Assembly Diagram  
Note: Placement of the Temperature/Humidity Sensor may vary.

## Check Temperature/Humidity Sensor Orientation

The orientation and placement of the Temperature/Humidity sensor should be checked, and in many cases, should be reoriented. There are three ways the sensor could be mounted in an ISS:

- On the second to bottom-most plate of radiation plating stack with the Temperature/Humidity sensor facing up.
- Underneath the top plate of the radiation plating stack, on the insulating disk with the Temperature/Humidity sensor facing down.
- On the second to bottom-most plate of the radiation plating stack with the Temperature/Humidity sensor mounted on spacers, facing down.

If the Temperature/Humidity sensor is mounted on the second to bottom-most plate with the sensor facing down, it is in the correct orientation and does not need to be repositioned in the stack.

If the Temperature/Humidity Sensor is placed in one of the other two positions, it should be removed from its current position and remounted in the correct position shown above.

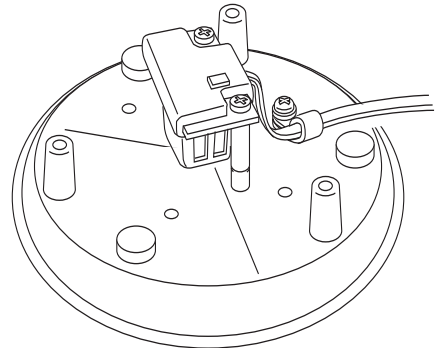

*Temperature/Humidity Sensor correctly mounted on spacers*

## Reinstall the Temperature/Humidity Sensor — For Sensors Facing Up

1. Locate the Temperature/Humidity sensor on the second to bottom plate in the radiation shield plating stack.
2. Remove the three screws, flat washer, and cable clamp securing the Temperature/Humidity sensor to the radiation plating. Save the small screw, flat washer, and cable clamp for use later.

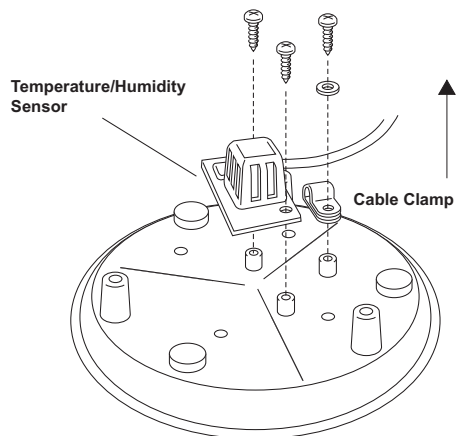

*Removing Temperature/Humidity Sensor with sensor mounted up*

3. Reinstall the sensor face down on the radiation plate, using the two 1' spacers and #4 screws included with the kit.
4. Put the cable clamp back on the cable and use the screw and flat washer to resecure the cable onto the radiation plate.
5. Replace the radiation plate back in its correct place in the radiation shield plating stack.

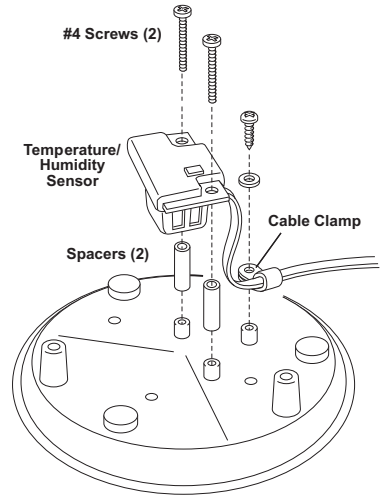

*Reinstalling Temperature/Humidity Sensor with Sensor Mounted Down*

### **Reinstall the Temperature/Humidity Sensor — For Sensors on the Insulating Disk**

1. Locate the plate at the top of the radiation shield plating and find the insulating disk with the Temperature/Humidity sensor on the underside of the radiation shield.
2. Remove the three screws, flat washer, and cable clamp securing the Temperature/Humidity sensor to the insulating disk. Save the small screw, flat washer, and cable clamp for use later.
3. Remove the two screws holding the insulating disk attached on the underside and discard the disk.
4. Reinstall the sensor face down on the second to bottom-most radiation plate, using the two 1' spacers and #4 screws included with the kit. See figure Reinstalling Temperature/Humidity Sensor with Sensor Mounted Down for more information on mounting the sensor.

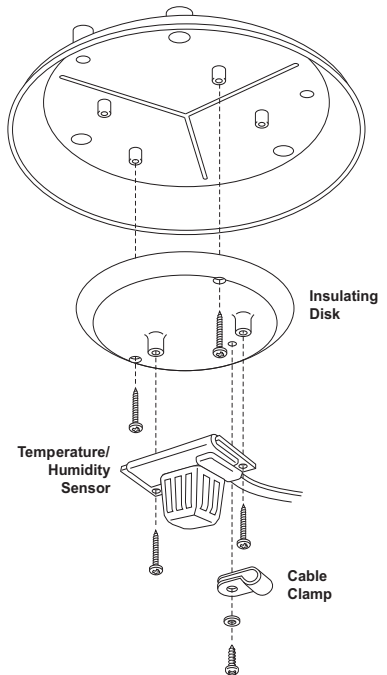

*Removing Temperature/Humidity Sensor with sensor mounted on Insulating Disk*

5. Put the cable clamp back on the cable and use the screw and flat washer to resecure the cable onto the radiation plate.
6. Replace the radiation plate back in its correct place in the radiation shield plating stack.

### Assemble the Lower Section

Once the existing radiation shield has been disassembled and the Temperature/Humidity sensor has been mounted correctly in the radiation plating stack, the existing disks have to be re-organized and assembled with the fan-aspirated kit. To reassemble the radiation shield with the new fan-aspirated shielding:

1. Locate the plate at the top of the radiation shield plating and find the insulating disk on the underside of the radiation shield.
2. Remove the two screws holding insulating disk attached on the underside and discard it. Save the top plate for use in Step 3.
3. Start building the lower section of the new radiation shield, starting with the original bottom plate on bottom and the disassembled top plate above that.
4. Place the plate containing the Temperature/Humidity sensor and the two open plates on top of the two bottom plates.

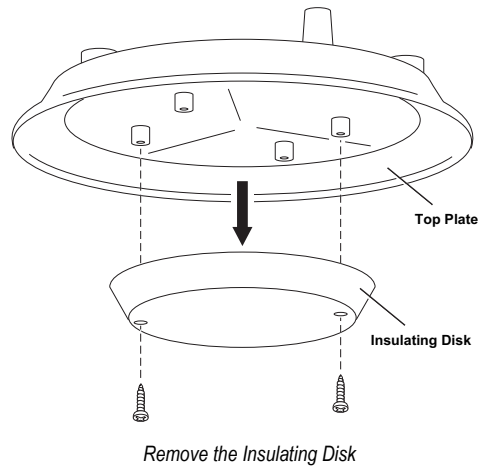

---

Note: When stacking plates, make sure the screw bosses (holes) line up with each other.

---

5. Place the third open plate (supplied with the fan-aspirated kit) on the stack.

6. Run the Temperature/Humidity cable through the top of the three open plates.

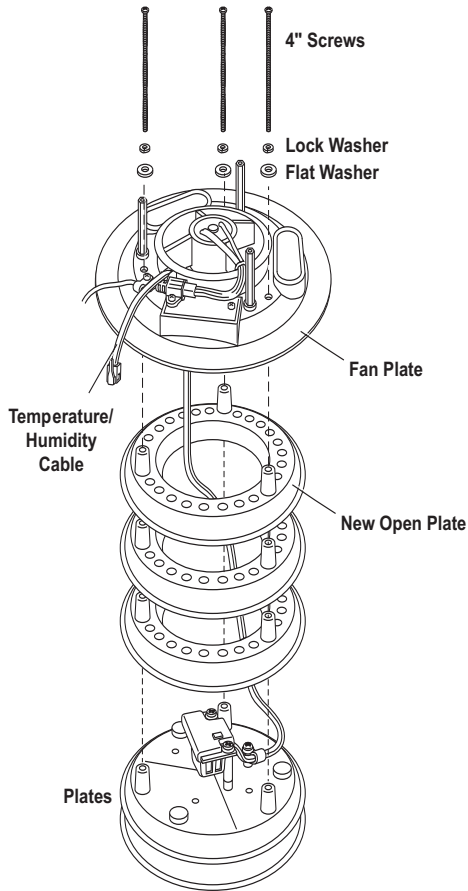

*Reassemble the Radiation Shield Plates with the Fan Plate*

7. Set aside the re-assembled radiation shielding and find the fan plate motor assembly.



- Attach the three threaded spacers to the fan plate using the three #8-32 x 1/2" screws and the three #8 washers and #8 lock washers included with the kit.

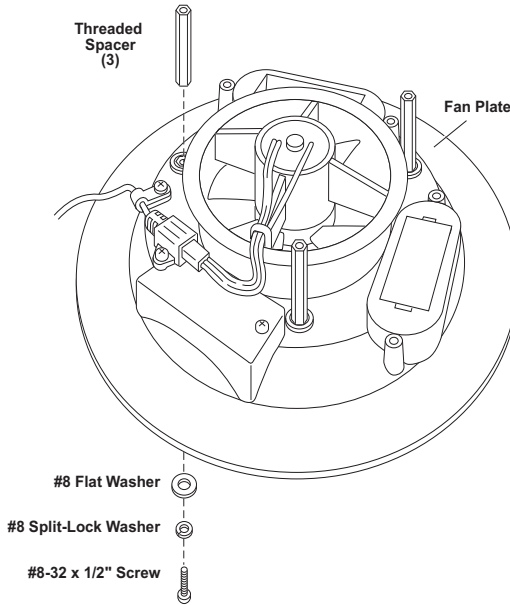

*Install Threaded Spacers*

- Detach the fan motor cable from the power cable assembly on the fan plate and set the fan motor aside.

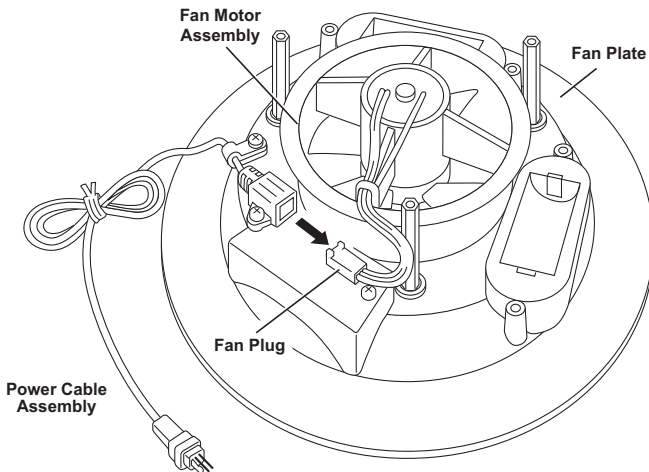

*Detach Fan Motor Cable*

- Lower the Fan Plate onto the radiation shielding stack.

11. Bring the Temperature/Humidity cable over the top of the fan plate so that no slack in the cable exists between the sensor and the fan plate and press it firmly into the cable channel on the fan plate.

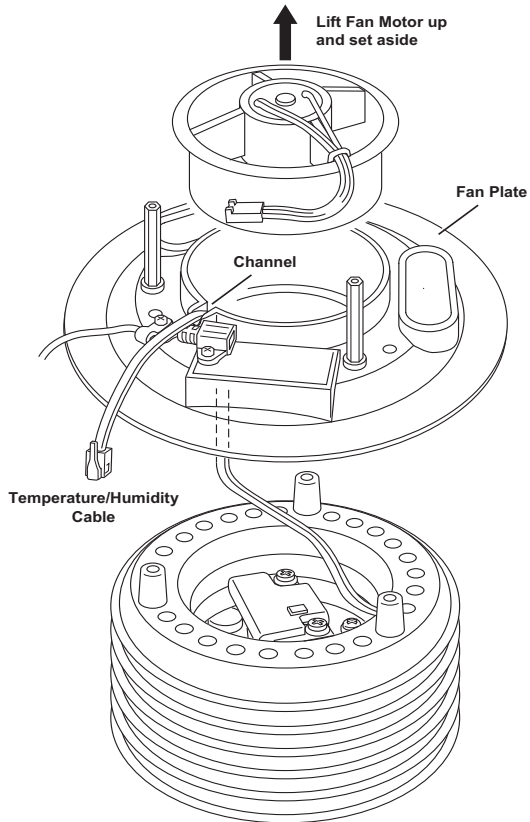

*Connecting the Radiation Shield and Fan Unit*

12. Place one of the 4" screws removed from the original radiation shield and its corresponding #8 lock washer and #8 flat washer into one of the radiation shield plate holes on the fan plate located just counter-clockwise from a threaded spacer, making sure the screw goes through the boss in each of the plates and lines up with the threaded insert located in the bottom plate.

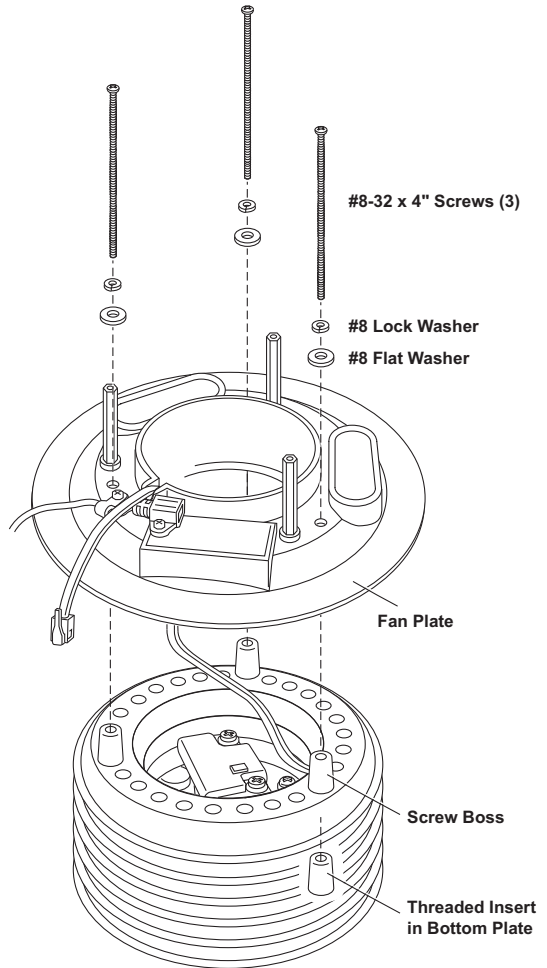

*Installing the Fan Plate onto the Radiation Shield*

13. Turn the screw to engage the threaded insert in the bottom plate.
14. Make sure the other screw bosses are aligned and then insert the other two 4" screws and corresponding washers in the same way.
15. Tighten all three screws to securely fasten the bottom section of the radiation shield.
16. Place the fan motor back into place and plug the fan motor cable back into the power cable assembly.
17. Unscrew the cable clamp holding the power cable assembly in place.
18. Thread the Temperature/Humidity cable into the cable clamp and tighten the screw back down in its original placement.
19. Place the cap plates on top of the rest of the radiation shield and line up their bosses.

20. Insert one of the 3 1/4" screws and corresponding lock and flat washers included in the kit hardware into the ISS base

**Radiation Shield Mounting Holes (3)**

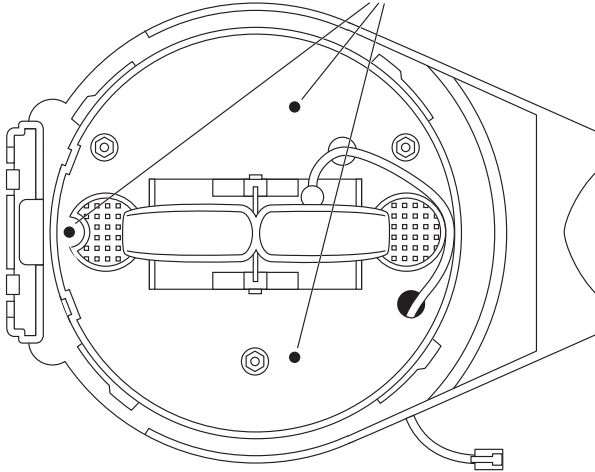

*Radiation Shield Mounting Holes in ISS base*

21. Lower the ISS base onto the stack so that the screw goes into the boss. Turn the screw a few times to engage the threads.
22. Place a lock washer and flat washer on the other two 3 1/4" screws then insert them through the other two screw holes.
23. Tighten all three screws to securely fasten the radiation shield to the ISS base.

### Re-Install the ISS

1. Install the rain collector cone and lock it in place.
2. Slide the Temperature/Humidity cable and the fan-aspirated unit's solar power cable assembly through the cable access port of the SIM box.
3. Connect the Temperature/Humidity sensor cable.
4. Close the SIM cover temporarily without connecting the solar panel cables.
5. Test communication between the ISS and the console. To test communication, take the console out of Setup Mode and make sure the console is receiving data from the ISS. See the ISS manual for more information on testing communication.
6. Reinstall the ISS in its previous location.
7. Open the SIM cover and connect the WIND (anemometer) cable.
8. **Cabled ISS Only:** Connect the console cable.

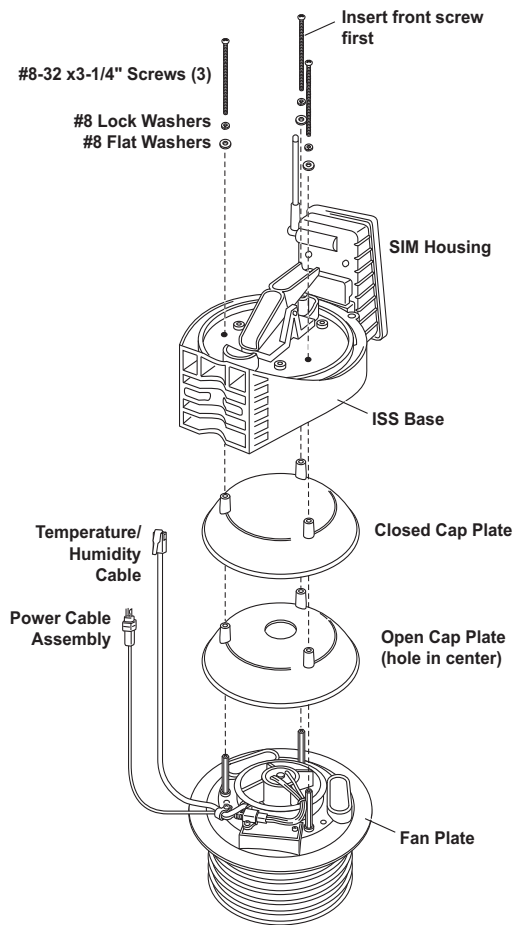

*Reconnecting the Radiation Shield to the Rain Collector*

9. Connect the wire coming from the top solar panel on the SIM cover included in the components of the fan-aspirated unit to the SIM board.

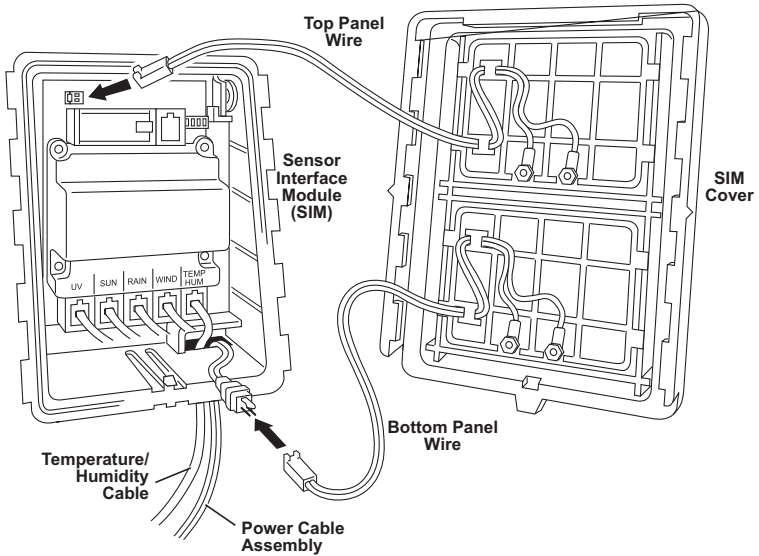

Connecting the Solar Panel Wires

10. Connect the wire coming from the bottom solar panel to power cable assembly in the SIM Box.
11. Reinsert the foam into the cable access port in the SIM box.
12. Close the SIM box.
13. Use cable ties to secure cables.
14. Make sure the fan blades are rotating by directing the connected SIM cover to sunlight or by shining a bright incandescent light on the solar panel.  
You should hear a slight whir if the fan is running.

### Guidelines for Securing Cables

- Secure cables so they will not whip in the wind.
- Secure cables to metal poles by using a cable tie or by wrapping electrical tape around them both.
- Place clips or ties approximately every 3 to 5 feet (1 to 1.6 m).
- If needed, additional cable ties, cable tie mounts, and other hardware can be obtained at a hardware or electronics store.

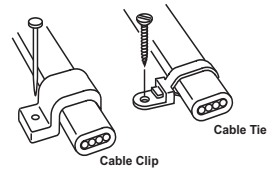

Securing Cables

**Note:** Do not use metal staples or a staple gun to secure cables. Metal staples—especially when installed with a staple gun—have a tendency to cut the cables.

---

### Take the Console Out of Setup Mode

1. At your Vantage Pro2 console, press and hold DONE for three seconds to take the console out of Setup Mode.
2. Check the console for erroneous rain data and clear if necessary.

To clear erroneous daily rain data:

- Select the RAINDAY button. The graph icon displays next to the daily rain variable.
  - Press and release 2ND, then immediately press and hold CLEAR.
  - The daily rain variable will start blinking.
  - Keep holding CLEAR until the reading changes to zero.
  - Refer to your *Vantage Pro2 Console Manual* for more information on clearing any other weather variables or clearing all weather variables in the console.
3. Congratulations! You have completed the upgrade and can now enjoy your daytime fan-aspirated radiation shield.

## Maintenance

- Keep the surfaces of the ISS clean, since the radiation shield and solar panel are less effective when dirty. Remove dust from the solar panel and radiation shield with a damp cloth.
- Remove any debris obstructing air flow through the radiation shield such as leaves, twigs, webs, and nests.
- Do not spray the ISS with insecticides of any kind. Some insecticides can damage the sensors and even damage the radiation shield.

### Annual Maintenance

We recommend cleaning out any debris that may have accumulated inside the radiation shield and replacing the motor (# 7758) on an as needed basis. The routine procedures for annual maintenance include:

1. Remove your fan-aspirated ISS and place on a stable work surface.
2. Check to see if the fan motor is still working. If it is not running, replace the motor with a new motor (# 7758).
3. Disassemble the radiation shield.
4. Remove any debris lodged inside the unit.
5. Clean the surfaces of the radiation shield with a damp cloth.
6. Assemble the radiation shield.
7. Re-install the ISS in its previous location.

---

## Contacting Davis Technical Support

If you are experiencing problems performing the upgrade or have problems with your Daytime Fan-Aspirated Radiation Shield, first be sure to check all cable connections. If you are unable to solve the problem, please call Davis Technical Support. We'll be glad to help. Most questions can be answered over the phone. You can also email us for support or visit our website. Sorry, we are unable to accept collect calls.

---

Note: Please do not return items to the factory for repair without prior authorization.

---

**(510) 732-7814** — Monday - Friday, 7:00 a.m. - 5:30 p.m. Pacific Time. We are unable to accept collect calls.

**(510) 670-0589** — Technical Support Fax.

**support@davisnet.com** — E-mail to Technical Support.

**info@davisnet.com** — General e-mail.

**www.davisnet.com** — Davis Instruments web site. See the Weather Support section for copies of user manuals, product specifications, application notes, and information on software updates. Watch for FAQs and other updates.

### FCC Part 15 Class B Registration Warning

This equipment has been tested and found to comply with the limits for a Class B digital device, pursuant to Part 15 of the FCC Rules. These limits are designed to provide reasonable protection against harmful interference in a residential installation. This equipment generates, uses, and can radiate radio frequency energy and, if not installed and used in accordance with the instructions, may cause harmful interference to radio communications.

However, there is no guarantee that interference will not occur in a particular installation. If this equipment does cause harmful interference to radio or television reception, which can be determined by turning the equipment on and off, the user is encouraged to try to correct the interference by one or more of the following measures:

- Reorient or relocate the receiving antenna.
- Increase the separation between the equipment and receiver.
- Connect the equipment into an outlet on a circuit different from that to which the receiver is connected.
- Consult the dealer or an experienced radio/TV technician for help.

Changes or modification not expressly approved in writing by Davis Instruments may void the warranty and void the user's authority to operate this equipment.

### EC EMC Compliance

This product complies with the essential protection requirements of the EC EMC Directive 89/336/EC.

**FC** Tested to comply  
with FCC standards  
FOR HOME OR OFFICE USE



### Addendum, Fan-Aspirated ISS Installation

Document Part Number: 7395.236

Rev. B, February 7, 2008

Product Number:7747

Vantage Pro<sup>®</sup> and Vantage Pro2<sup>™</sup> are trademarks of Davis Instruments Corp., Hayward, CA.

© Davis Instruments Corp. 2008. All rights reserved.

Information in this document subject to change without notice.

**DAVIS**   
**Davis Instruments**

3465 Diablo Avenue, Hayward, CA 94545-2778 U.S.A.

510-732-9229 • Fax: 510-732-9188

E-mail: info@davisnet.com • www.davisnet.com