

## BMW Key Programmer user manual

1. Handle EWS, firstly disconnect CPU 20pin with circuit board, please refer to the following pictures.

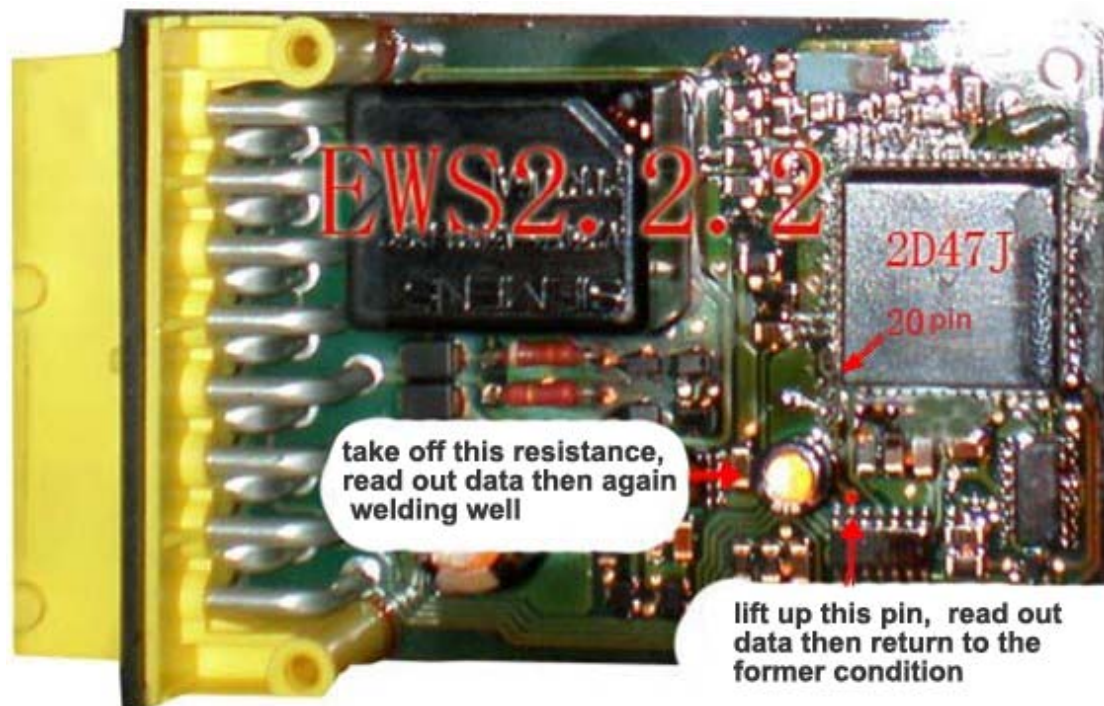



Then, handle well every pin of CPU, correctly put the IC socket

of BMW Key Programmer on 68HC11EA9 CPU. BMW Key Programmer support directly read out data and program key for EWS2 2D47J, EWS3 0D46J and EWS3+ 0D46J.

Plus, as for a small part of rare EWS2 1D47J and EWS3 2D47J, it needs related programmer to read out data, then to program key. **(IMPORTANT NOTE: make sure not use BMW key programmer to read out the data of EWS3 2D47J)**

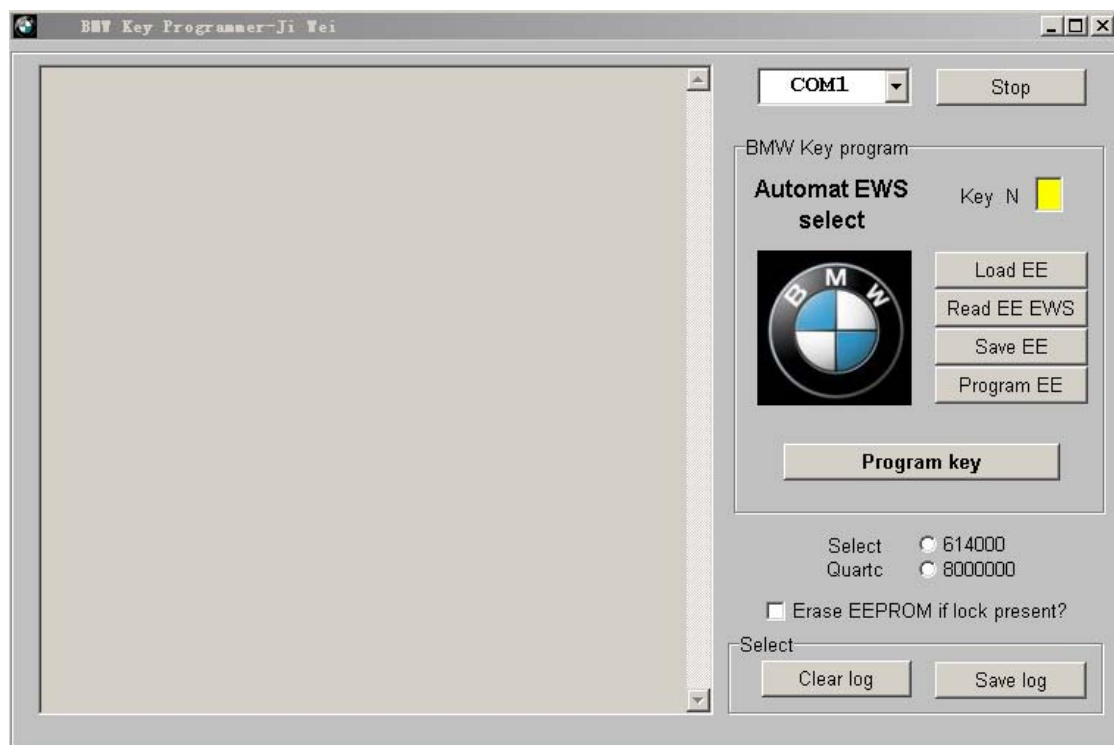
2. Connect BMW KEY PROGRAMMER with computer, open operation software, as follows:



3. Click  to choose Quartc, select 614000 to read EWS2 2D47J; select 8000000 to read EWS3 0D46J and EWS3+ 0D46J.

4. Click **Read EE EWS**, then display EWS data that was read out, see the following picture.

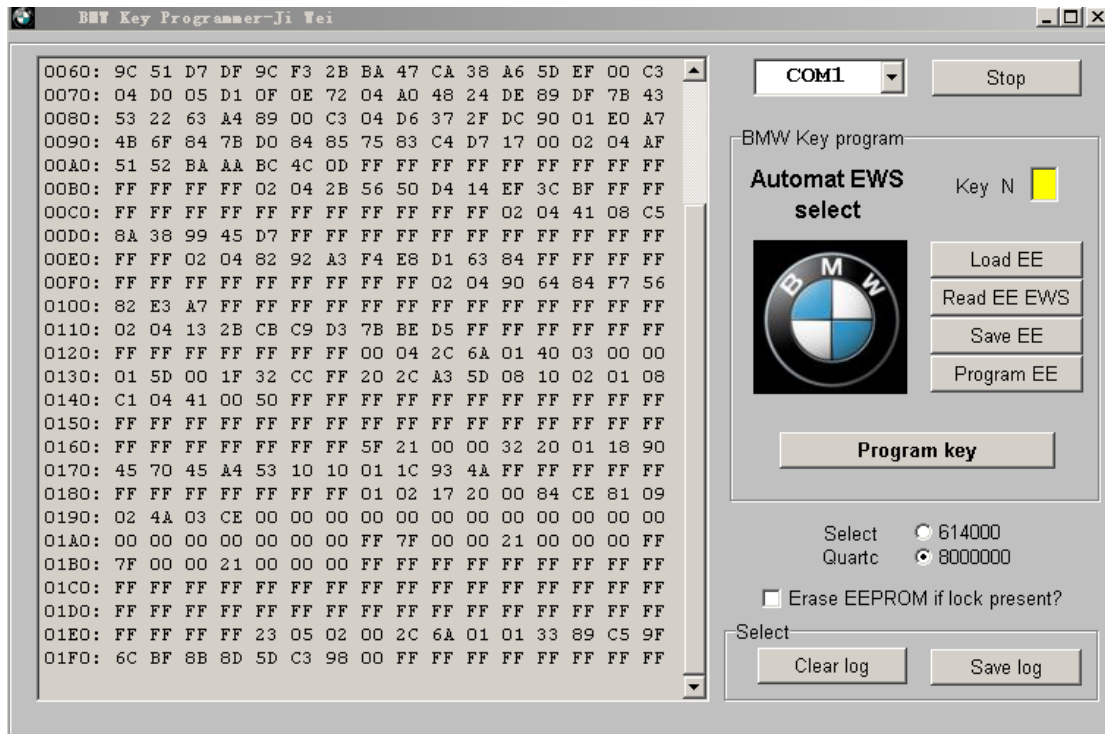

5. Click **Save EE**

6. Enter key position into **Key N** (From 0-9, it's 10 keys in total, if you don't want to erase the original car key, please enter the key from 3-9 )

7. Put key or chip (PCF7930, 7931, 7935) into BMW KEY PROGRAMMER key keyhole, see the picture as follows:



8. Click **Program key** to program key, it usually cost 30 seconds.

9. **Programming OK** Displays, once key is successfully programmed.

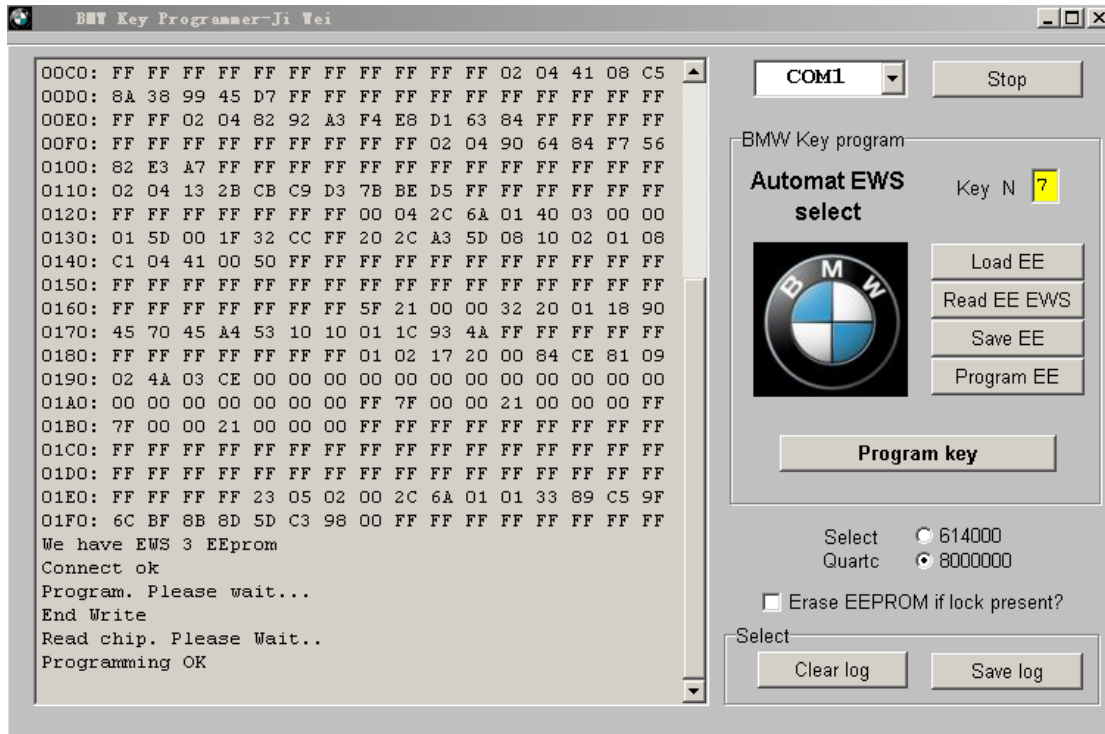

10. Welding well CPU 20PIN with circuit board

11. Put EWS into the car, use the cloned key to turn on ignition, do not start, wait about 20 seconds, turn off ignition, don't take out key, restart, now all is ok!