



# Smart GPS Antenna A1035-D

A description of Tyco Electronics'  
GPS antenna module A1035-D

## User's Manual

Version 1.3  
Hardware Revision 01

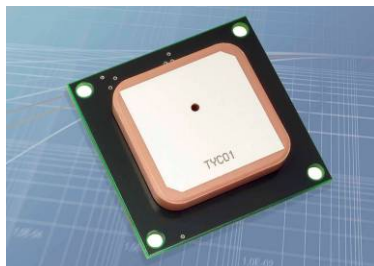

**This page was intentionally left blank.**

## Revision History

Rev.	Date	Description
1.0	05-22-07	Initial Draft – preliminary information
1.1	11-06-07	PTF function added
1.2	12-06-07	Minor corrections
1.3	26-03-08	Tray specifications changed
	mm-dd-yy	

## **Disclaimer**

THIS DOCUMENT CONTAINS PROPRIETARY INFORMATION OF TYCO ELECTRONICS CORPORATION/POWER SYSTEMS (TYCO ELECTRONICS). IT MAY NOT BE COPIED OR TRANSMITTED BY ANY MEANS, PASSED TO OTHERS, OR STORED IN ANY RETRIEVAL SYSTEM OR MEDIA, WITHOUT PRIOR CONSENT OF TYCO ELECTRONICS OR ITS AUTHORIZED AGENTS.

THE INFORMATION IN THIS DOCUMENT IS, TO THE BEST OF OUR KNOWLEDGE, ENTIRELY CORRECT. HOWEVER, TYCO ELECTRONICS CAN NEITHER ACCEPT LIABILITY FOR ANY INACCURACIES, OR THE CONSEQUENCES THEREOF, NOR FOR ANY LIABILITY ARISING FROM THE USE OR APPLICATION OF ANY CIRCUIT, PRODUCT, OR EXAMPLE SHOWN IN THE DOCUMENT.

THE PRODUCT (HARD- AND SOFTWARE) DESCRIBED IN THIS DOCUMENTATION IS NOT AUTHORIZED FOR USE IN LIFE SUPPORT DEVICES OR SYSTEMS WITHOUT THE EXPRESS WRITTEN APPROVAL OF TYCO ELECTRONICS.

THIS DOCUMENT MAY PROVIDE LINKS TO OTHER WORLD WIDE WEB SITES OR RESOURCES. BECAUSE TYCO ELECTRONICS HAS NO CONTROL OVER SUCH SITES AND RESOURCES, TYCO ELECTRONICS SHALL NOT BE RESPONSIBLE FOR THE AVAILABILITY OF SUCH EXTERNAL SITES OR RESOURCES, AND DOES NOT ENDORSE AND IS NOT RESPONSIBLE OR LIABLE FOR ANY CONTENT, ADVERTISING, PRODUCTS, OR OTHER MATERIALS ON OR AVAILABLE FROM SUCH SITES OR RESOURCES. TYCO ELECTRONICS SHALL NOT BE RESPONSIBLE OR LIABLE, DIRECTLY OR INDIRECTLY, FOR ANY DAMAGE OR LOSS CAUSED OR ALLEGED TO BE CAUSED BY OR IN CONNECTION WITH USE OF OR RELIANCE ON ANY SUCH CONTENT, GOODS OR SERVICES AVAILABLE ON OR THROUGH ANY SUCH SITE OR RESOURCE.

TYCO ELECTRONICS RESERVES THE RIGHT TO CHANGE, MODIFY, OR IMPROVE THIS DOCUMENT OR THE PRODUCT DESCRIBED HEREIN, AS SEEN FIT BY TYCO ELECTRONICS WITHOUT FURTHER NOTICE.

## Table of Contents

<b>1 Introduction</b> .....	<b>7</b>
1.1 Label .....	7
1.2 Characteristics .....	8
1.3 Mechanical Characteristics .....	8
1.4 Handling Precautions .....	8
<b>2 Ordering Information</b> .....	<b>9</b>
2.1 GPS Receiver A1035-D .....	9
2.2 Packing .....	9
2.3 Additional Equipment .....	10
<b>3 Quick Start</b> .....	<b>11</b>
3.1 Minimum Configuration .....	11
3.2 Serial Port Settings .....	12
3.3 Improved TTFB .....	12
<b>4 Mechanical Outline</b> .....	<b>13</b>
4.1 Overview A1035-D .....	13
4.2 Connector A1035-D .....	15
<b>5 Pin-out Information</b> .....	<b>16</b>
5.1 Layout A1035-D .....	16
5.2 Description A1035-D Signals .....	17
5.3 General Comments .....	18
<b>6 Electrical Characteristics</b> .....	<b>19</b>
6.1 Operating Conditions .....	19
6.2 Absolute Maximum Ratings .....	19
<b>7 Mounting</b> .....	<b>19</b>
<b>8 Quality and Reliability</b> .....	<b>20</b>
8.1 Environmental Conditions .....	20
8.2 Product Qualification .....	20
8.3 Production Test .....	20
<b>9 Applications and Hints</b> .....	<b>21</b>
9.1 Minimum Configuration .....	21
9.2 Battery Back-up .....	21
9.3 1PPS pin (1 pulse per second pin) .....	22
9.4 Reset Signal .....	22
9.4.1 Internal reset circuit .....	22
9.4.2 External reset circuit .....	22
9.5 Push-to-Fix Mode .....	24
<b>10 Demonstration Kit A1035-D</b> .....	<b>24</b>
<b>11 Related Information</b> .....	<b>25</b>

11.1 Contact.....	25
11.2 Related Documents.....	25
<b>12 List of Tables .....</b>	<b>27</b>
<b>13 List of Figures .....</b>	<b>27</b>

## 1 Introduction

Tyco Electronics' smart GPS antenna A1035-D is the combination of a highly integrated GPS receiver module and a ceramic GPS patch antenna. The antenna is connected to the module via an LNA. The module is capable of receiving signals from up to 20 GPS satellites and transferring them into position and timing information that can be read over a serial port. Small size and high-end GPS functionality are combined at low power consumption:

- Operable at 3.3V / 41mA (typ.) @ 1fix per second
- UART interface at CMOS level
- Small form factor of 35.6 x 35.6 mm (1.4" x 1.4")
- Standard power and I/O connector
- Mountable without solder process
- Field replaceable

The smart antenna module is available as an off-the-shelf component, 100% tested and shipped in trays.

**NOTE:** The module can be offered for OEM applications with adaptation in form and connection. Additionally, the antennas can be tuned to their final environment.

### 1.1 Label

The A1035-D's labels hold the following information:

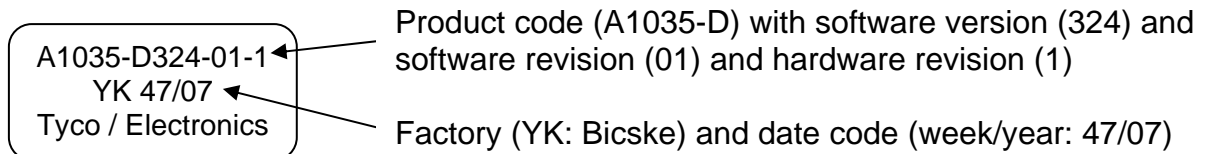

Figure 1: A1035-D labels

## 1.2 Characteristics

The antenna modules are characterized by the following parameters.

Channels		20, parallel tracking
Correlators		200.000 plus
Frequency		L1 (= 1575 MHz)
Tracking Sensitivity		-159dBm
Position Accuracy	Stand alone	< 10m CEP (SA off)
Time To First Fix – TTFF (theoretical minimum values; values in real world may differ)	Obscuration recovery <sup>(1)</sup>	0.1s
	Hot start <sup>(2)</sup>	< 1s
	Warm <sup>(3)</sup>	< 32s
	Cold <sup>(4)</sup>	< 35s

Table 1: A1035-D characteristics

- (1) The calibrated clock of the receiver has not stopped, thus it knows precise time (to the  $\mu$ s level).
- (2) The receiver has estimates of time/date/position and valid almanac and ephemeris data.
- (3) The receiver has estimates of time/date/position and recent almanac.
- (4) The receiver has no estimate of time/date/position, and no recent almanac.

## 1.3 Mechanical Characteristics

Mechanical dimensions	Length	35.56mm, 1.4"
	Width	35.56mm, 1.4"
	Height	8.0mm, 0.315"
Weight		12g, 0.5oz (may vary)

Table 2: A1035-D dimensions and weight

## 1.4 Handling Precautions

The smart GPS antenna A1035-D is a module that is sensitive to electrostatic discharge (ESD). Please handle with appropriate care.



## 2 Ordering Information

### 2.1 GPS Receiver A1035-D

The order numbers are built as follows:

- V23993A1035Dxxx

“V23993” stands for Tyco Electronics’ wireless and communication products, the “A1035-D” for the A1035-D module. The “xxx” stands for the according firmware version. If no firmware version is noted in an order, the latest version will be provided.

### 2.2 Packing

The A1035-D comes in trays, with 35 modules per tray and 5 trays per box.

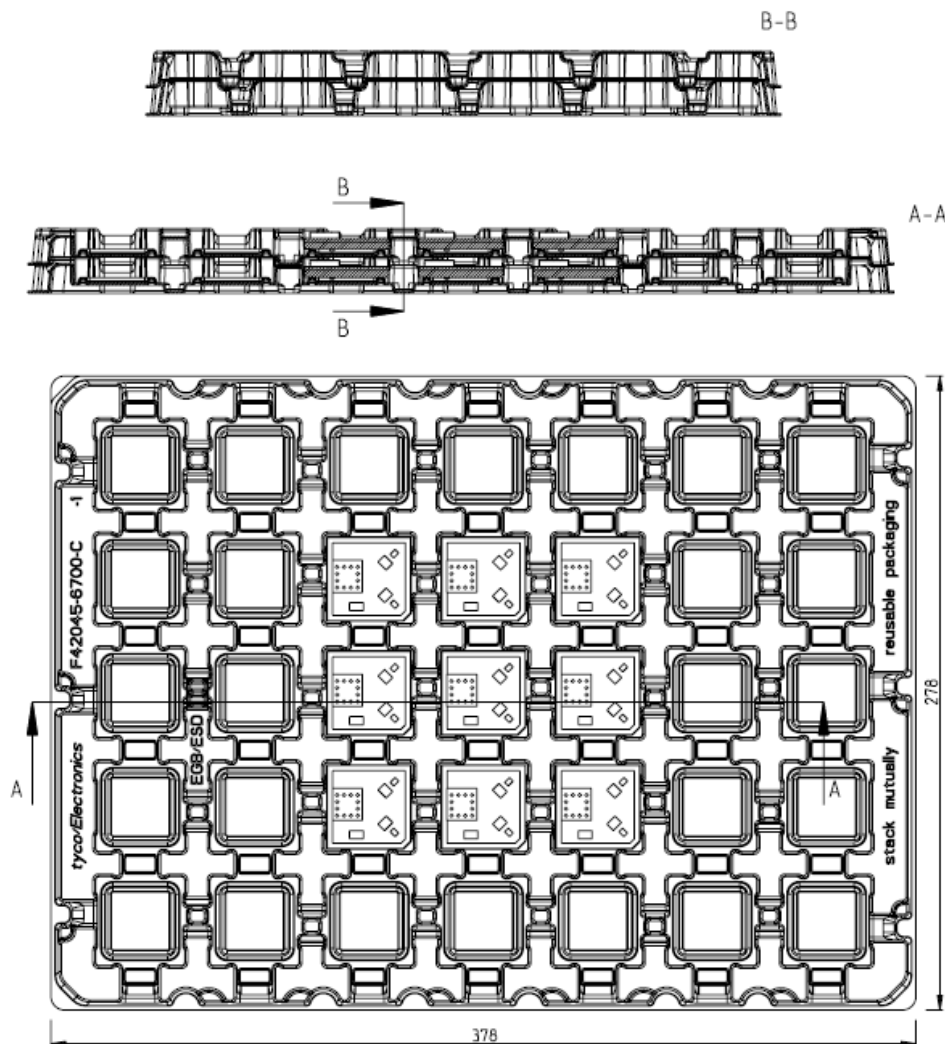

Figure 2: A1035-D tray specification (1)

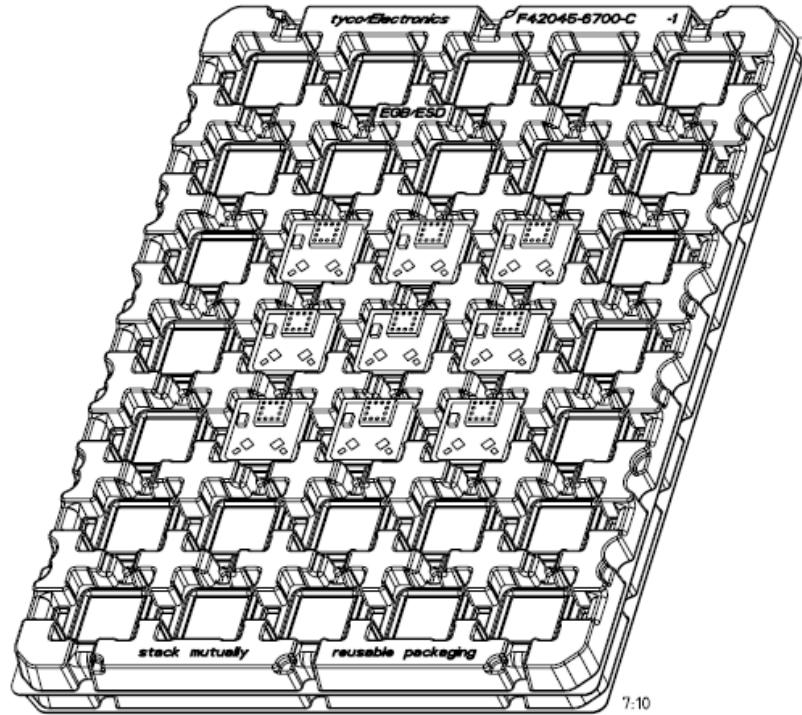

Figure 3: A1035-D tray specification (2)

## 2.3 Additional Equipment

V23993DKS1035D	Demonstration Kit (including one module V23993A1035D)
----------------	---

Table 3: Additional equipment

Detailed descriptions of the additional kits can be found in the according manuals.

### 3 Quick Start

In order to allow an easy and quick start with the modules A1035-D, this chapter provides a short overview on the most important steps to receive NMEA messages with position information on a serial port. For details please refer to the according chapters.

#### 3.1 Minimum Configuration

The following picture shows a recommended minimum configuration for NMEA output and commands received and sent via an RS232 interface.

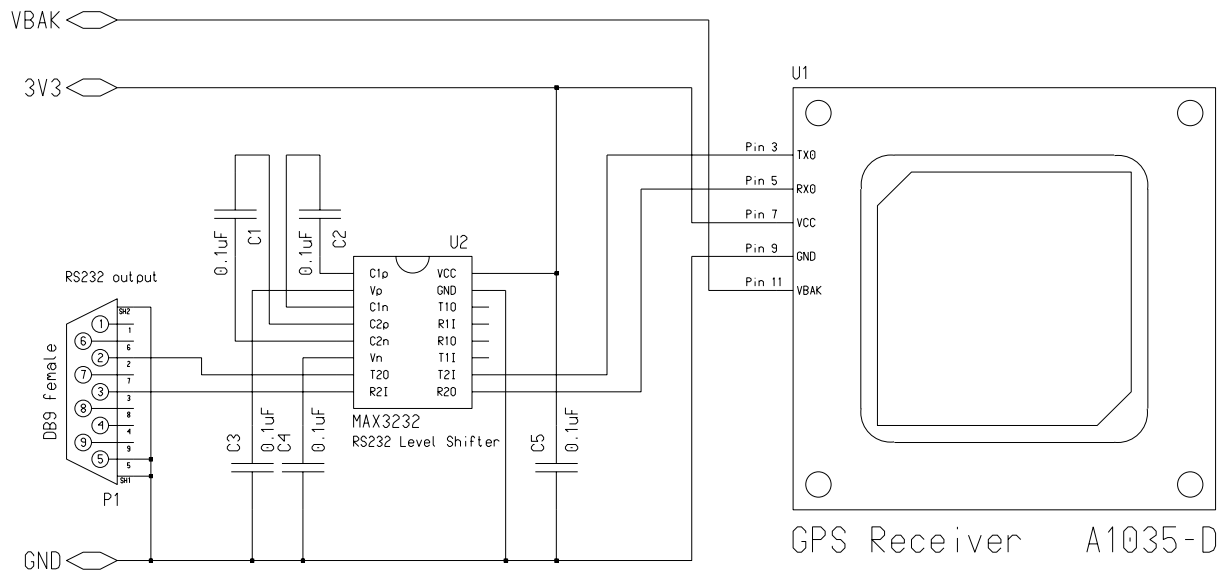

Figure 4: Recommended minimum configuration A1035-D

#### Remarks:

- Place C1 to C5 close to MAX3232. For capacity values see datasheet of actual component used.
- Use 3.3V level shifter (MAX3232 or equivalent).
- A battery back-up circuit for the RTC (Real Time Clock) should be considered (see below)!

### **3.2 Serial Port Settings**

The default configuration within the standard GPS firmware is:

- Serial 0 (NMEA) 4800 baud, 8 data bits, no parity, 1 stop bit, no flow control

### **3.3 Improved TTFF**

In order to improve the TTFF (Time To First Fix), it is recommended to support the RTC with a back-up power when no system power is available.

## 4 Mechanical Outline

### 4.1 Overview A1035-D

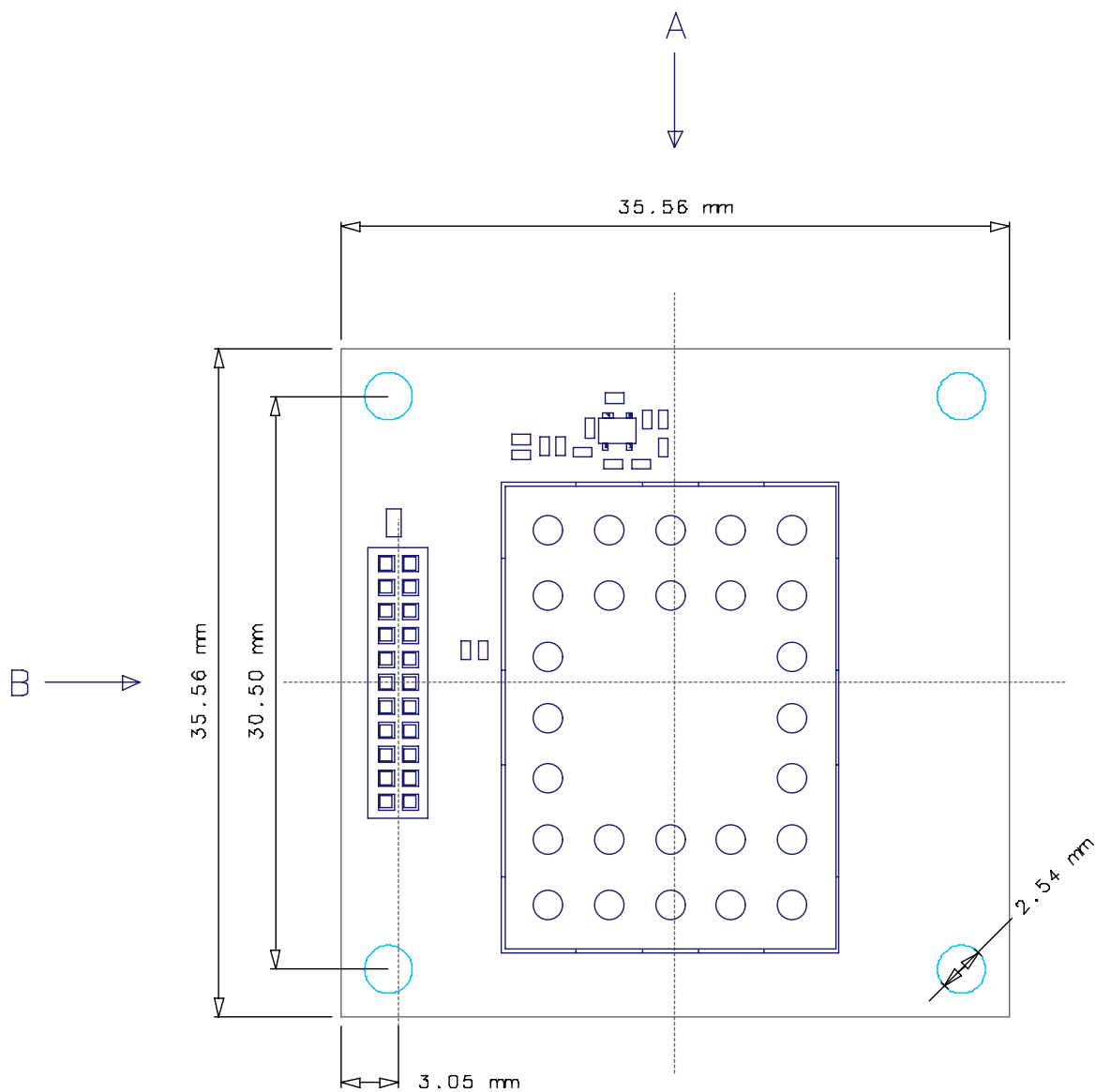

All dimensions in [mm]

Figure 5: Mechanical outline overview A1035-D (bottom)

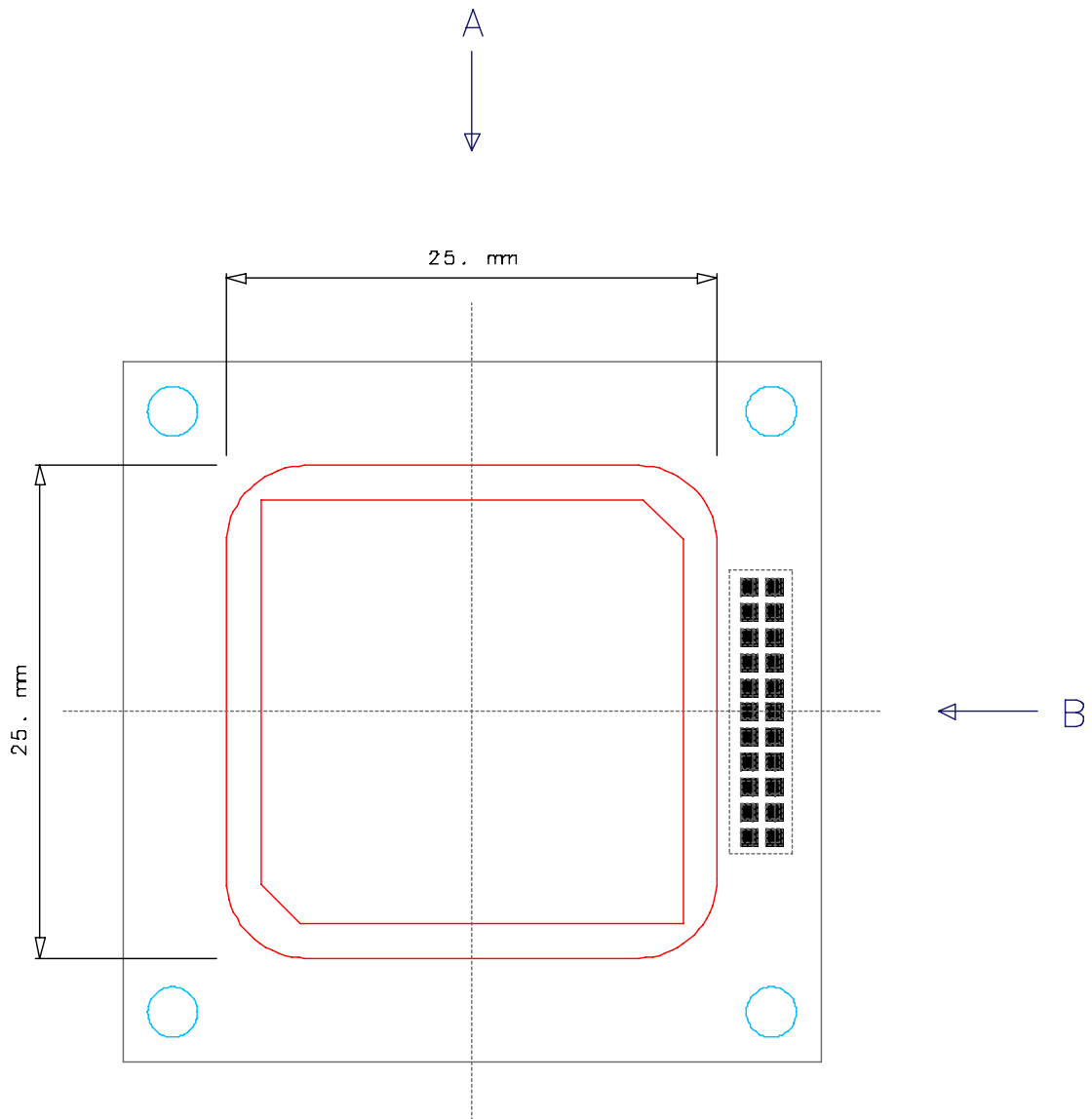

All dimensions in [mm]

Figure 6: Mechanical outline overview A1035-D (top)

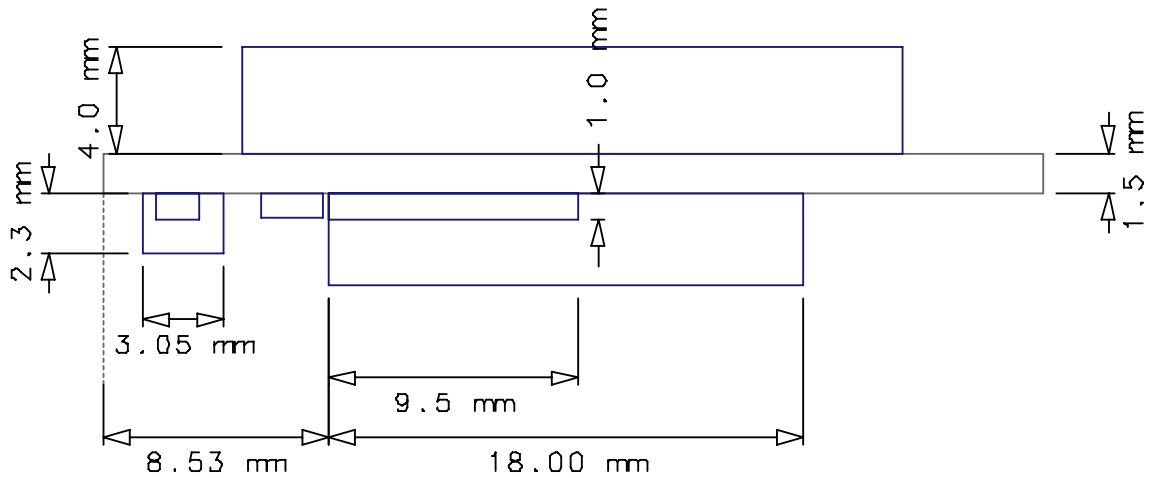

All dimensions in [mm]

Figure 7: Mechanical outline overview A1035-D (side A)

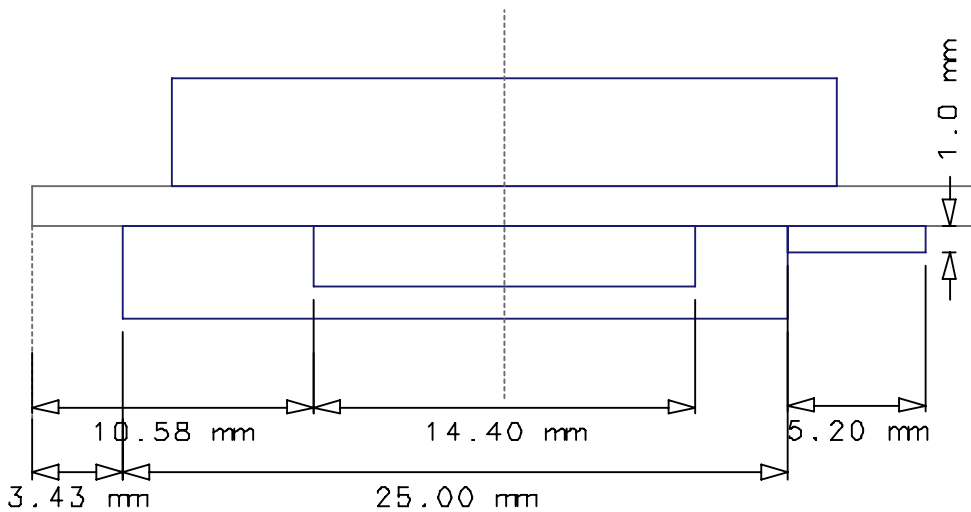

All dimensions in [mm]

Figure 8: Mechanical outline overview A1035-D (side B)

## 4.2 Connector A1035-D

The power and I/O connector used on the A1035-D is a 1.27mm (0.05") low profile, double row socket with a height of 2.21mm (.087") and a total of 22 contacts. Potential counterparts on the motherboard are e.g. Samtec 1.27mm (0.05") micro strips of the FTS series (e.g. FTS-111-02-L-DV-P-TR).

## 5 Pin-out Information

### 5.1 Layout A1035-D

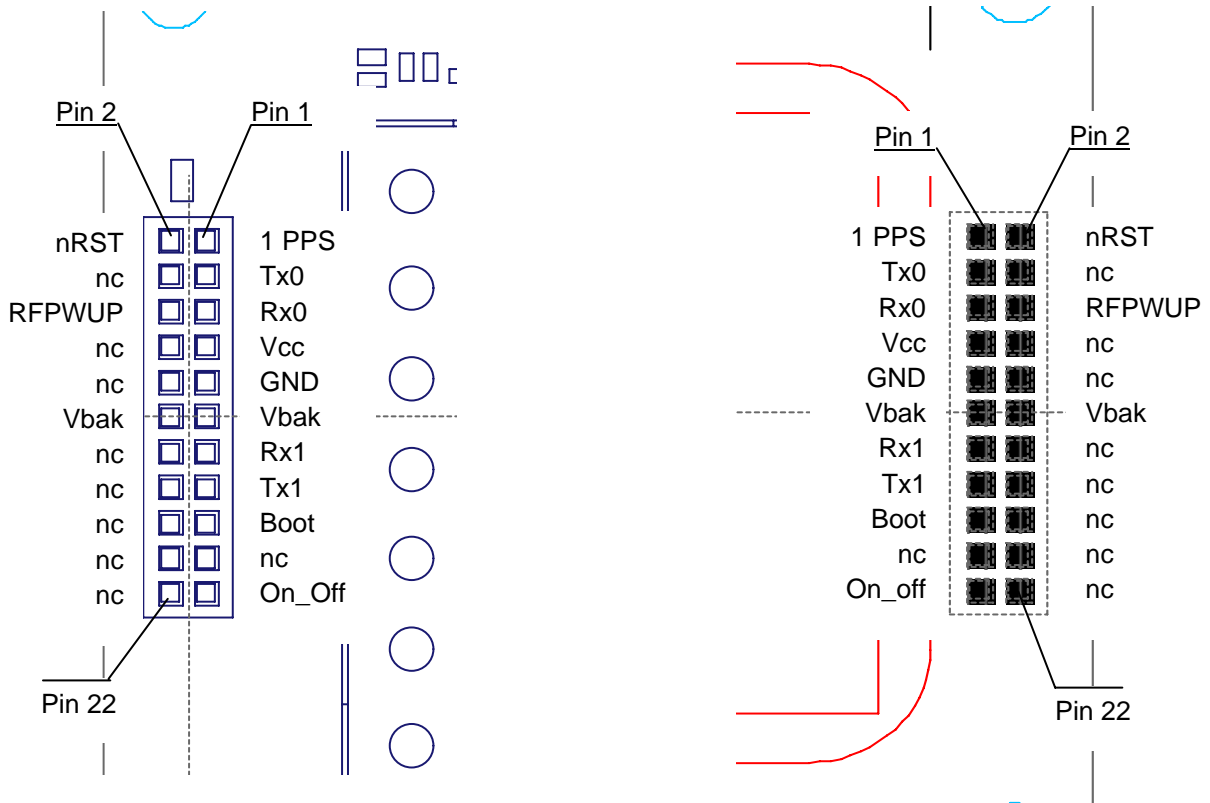

Figure 9: Pin out information A1035-D (bottom and top view)

Bottom view is showing the side of the module that will face the carrier board.



## 5.2 Description A1035-D Signals

This table describes the functionality of the pins and their associated symbols.

Pin	Symbol	Function	Description
1	1PPS	Output	1PPS (pulse per second) output
3	TX0	Output	Serial output 0, NMEA out
5	RX0	Input	Serial input 0, NMEA in
7	Vcc	Power Supply	3.0 – 3.6 VDC (power supply)
9	GND	Power Supply	Ground (power supply)
11	Vbak	Power Supply	Back-up pin of module for “super cap” or battery (see below)
13	RX1	Input	Serial input 1 – unused in current firmware (leave open)
15	TX1	Output	Serial output 1 – unused in current firmware (leave open)
17	BOOTSEL	Input	Special boot mode – leave open for normal operation
19	Res.		Reserved – leave open
21	ON_OFF	Input	ON_OFF, used in PTF mode to request fix by toggling from LOW to HIGH and back – leave open if not used

Table 4: Pin description A1035-D (part 1)

Pin	Symbol	Function	Description
2	nRST	Input	Reset input
4	Res.		Reserved – leave open
6	RFPWUP	Output	Status of analog section (Low = OFF, High = ON)
8	Res.		Reserved – leave open
10	Res.		Reserved – leave open
12	Vbak	Power Supply	Back-up pin of module for “super cap” or battery (see below)
14	Res.		Reserved – leave open
16	Res.		Reserved – leave open
18	Res.		Reserved – leave open
20	Res.		Reserved – leave open
22	Res.		Reserved – leave open

Table 5: Pin description A1035-D (part 2)

### **5.3 General Comments**

The following comments should be considered for a design with and use of the module:

- Standard configuration of serial port:  
Serial 0 (NMEA) 4800 baud, 8 data bits, no parity, 1 stop bit, no flow control

## 6 Electrical Characteristics

### 6.1 Operating Conditions

Pin	Description	Min	Typical	Max
12	$V_{bak}$	1.8V		3.6V
	Standby Current <sup>(4)</sup>		20 $\mu$ A	
7	$V_{cc}$	3.0V	3.3V	3.6V
	Peak Acquisition Current <sup>(1)</sup>		57mA	
	Average Acquisition Current <sup>(2)</sup>		41mA	
	Tracking Current <sup>(3)</sup>		36mA	

Table 6: Operating Conditions

- (1) Peak acquisition current is characterized by millisecond bursts above average acquisition current
- (2) Average current is typically only the first two seconds of TTFF
- (3) Tracking current typically includes tracking and the post acquisition portion of TTFF
- (4) During standby state: RTC block and core powered on and clock off.

### 6.2 Absolute Maximum Ratings

Pin	Description	Min	Max
7	$V_{cc}$	-0.3V	3.6V
	Applied voltage to all input pins excluding $V_{cc}$	-0.3V	$V_{cc}+0.3V$ max. 3.6V

Table 7: Absolute maximum ratings

Stresses beyond those listed under “Absolute Maximum Ratings” may cause permanent damage to the device. This is a stress rating only. Functional operation of the device at these or any other conditions beyond those indicated in the operational sections of this specification is not implied. Exposure to absolute maximum rating conditions for extended periods may affect device reliability.

## 7 Mounting

The A1035-D offers a power and I/O connector with a 1.27mm (0.05”) low profile, double row socket with a total of 22 contacts. Potential counterparts on the motherboard are Samtec 1.27mm (0.05”) micro strips of the FTS series. For fixing the A1035-D on a motherboard appropriate screws and bolts or clips (see also chapter 4 Mechanical Outline) are recommended.

## 8 Quality and Reliability

### 8.1 Environmental Conditions

Operating temperature	- 30 ... + 85°C
Operating humidity	Max. 85% r. H., non-condensing, at 85°C
Storage	6 months in original package.

Table 8: Environmental conditions

### 8.2 Product Qualification

Prior to product qualification the GPS receiver is preconditioned according to EIA/JEDEC standard JESD22-A113-B / Level 3.

Basic qualification tests:

- Temperature Cycling –30°C ... +85°C
- Temperature Humidity Bias 70°C / 85% RH
- High / Low Temperature Operating –30° / +85°C
- High Temperature Operating Life +85°C
- Vibration Variable Frequency
- Mechanical Shock

Please contact Tyco Electronics for detailed information.

### 8.3 Production Test

Each module is electrically tested prior to packing and shipping to ensure state of the art GPS receiver performance and accuracy.

## 9 Applications and Hints

### 9.1 Minimum Configuration

Please refer to chapter 3.1 Minimum Configuration for details. In addition, for optimized start-up behavior it is strongly recommended to add a battery back-up circuit (see chapter 3.3)!

### 9.2 Battery Back-up

This application note describes on how to back-up the RTC and the SRAM of the GPS receiver module. The basic of the first examples is to provide a back-up by a separate battery or a “supercap”.

While the “supercap” is charged thru the module during normal operation, the battery (primary cell) is decoupled thru a diode!

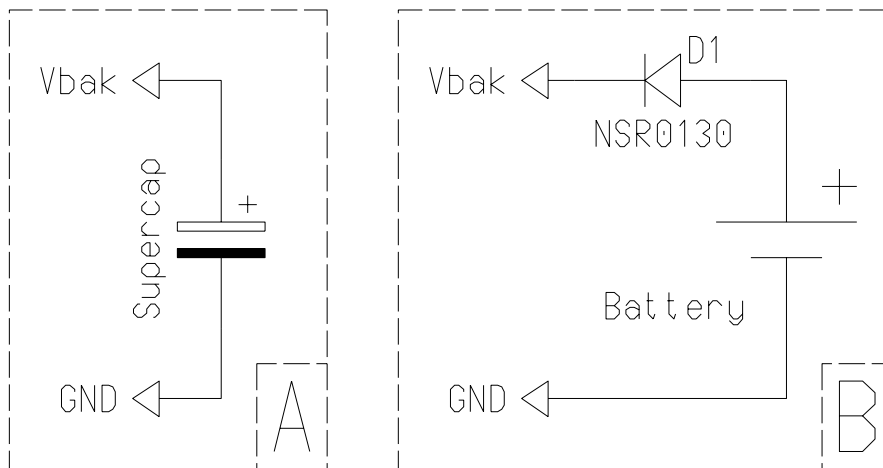

Backup Supply Options  
(A) Supercap, charged through GPS module  
(B) Primary cell, decoupled with diode

Figure 9: Application note: Module back-up

An alternative to this solution is to switch the supply voltage from the Vcc pin to the Vbak pin. Care needs to be taken that there is no voltage outage during the switch-over phase!

### **9.3 1PPS pin (1 pulse per second pin)**

The 1PPS pin is an output pin.

In addition to precise positioning, GPS also allows for accurate timing due to the synchronized atomic clocks in the GPS satellites. While the current date and time is transmitted in NMEA sentences, an exact and accurate timing signal is provided via the 1PPS pin of the A1035-D modules.

### **9.4 Reset Signal**

The nRST pin is an input pin.

The nRST pin can be used to generate a reset on the A1035-D module. Resetting the module will result in a restart of the complete firmware. All information stored in SRAM will still be valid.

#### **9.4.1 Internal reset circuit**

The A1035-D is already equipped with a voltage monitoring device that generates a proper power-on reset at the appropriate threshold and delay. Additionally it takes care about the brown-out protection. Usually there is no need to deal with the reset input externally, thus the general advice is to leave this pin open.

#### **9.4.2 External reset circuit**

If – for some reasons – an external reset input is really desired, the use is subject to following restrictions:

- (1) Never ever connect a capacitor of any size to the nRST pin.
- (2) Never ever pull the nRST pin actively high.
- (3) Only use an open drain/collector device (e.g. a bipolar NPN transistor to ground, see Fig. 1) to pull the nRST pin low in order to issue a reset.
- (4) Make sure that the nRST pulse is absolutely glitch free with sharp edges and lasts at least 100ms.

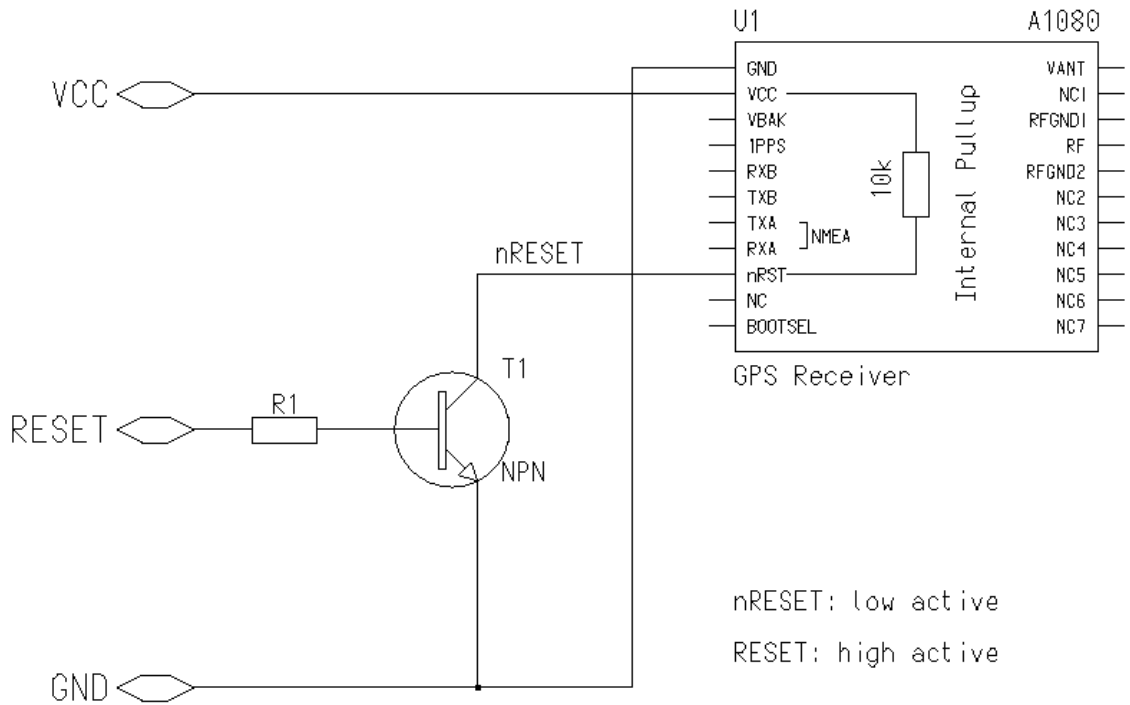

Figure 10: Application note: External reset circuit

## 9.5 Push-to-Fix Mode

The push-to-fix mode is initialized and entered using the SiRF Binary Protocol. Please refer to the according manual, especially the paragraph “Set TricklePower Parameters”. In order to request a fix outside the specified duty cycles, it is necessary to toggle the pin ON\_OFF.

Before you toggle pin ON\_OFF, the signal RFPWUP needs to be checked. Only if the status of RFPWUP is LOW, ON\_OFF should be toggled. Toggling is done by pulling the signal to HIGH for about 100ms.

## 10 Demonstration Kit A1035-D

For demonstration and easy evaluation of GPS performance Tyco Electronics offers a Demonstration Kit (including one smart GPS antenna A1035-D). It shows two serial interfaces, but only one is being used (NMEA). The Demonstration Kit can be powered by an external 5 to 12V source. Accompanied by a serial cable it offers a ready-to-go set. For further information please contact Tyco Electronics.



Figure 11: Demonstration kit DKS1035-D (identical to DKS1035-C shown here)

For further information please contact Tyco Electronics.



## 11 Related Information

### 11.1 Contact

This manual was created with due diligence. We hope that it will be helpful to the user to get the most out of the GPS module.

Anyway, inputs about errors or mistakable verbalizations and comments or proposals to TYCO Electronics, Power Systems in Munich, Germany, for further improvements are highly appreciated.

#### **Tyco Electronics**

#### **Power Systems**

Finsinger Feld 1

85521 Ottobrunn, Germany

Tel.: +49 89 6089 838

Fax: +49 89 6089 835

[gps@tycoelectronics.com](mailto:gps@tycoelectronics.com).

<http://www.tycoelectronics.com/gps>.

Further contact addresses:

[info.gps@tycoelectronics.com](mailto:info.gps@tycoelectronics.com).

[support.gps@tycoelectronics.com](mailto:support.gps@tycoelectronics.com).

[sales.gps@tycoelectronics.com](mailto:sales.gps@tycoelectronics.com).

### 11.2 Related Documents

- Manual: T.E. GPS Firmware A1080-A (TYCO)
- Manual: T.E. GPS DemoKit DKS1035 (TYCO)
- Manual: T.E. GPS Receiver A1080 (TYCO)
- Application note: GPS AN A1080-A – EDLC as Backup Supply V1.0 (TYCO)
- Application note: GPS AN A1080-A – Backup V1.0 (TYCO)

**This page was intentionally left blank.**

## 12 List of Tables

Table 1: A1035-D characteristics .....	8
Table 2: A1035-D dimensions and weight.....	8
Table 3: Additional equipment.....	10
Table 4: Pin description A1035-D (part 1).....	17
Table 5: Pin description A1035-D (part 2).....	17
Table 6: Operating Conditions .....	19
Table 7: Absolute maximum ratings.....	19
Table 8: Environmental conditions .....	20

## 13 List of Figures

Figure 1: A1035-D labels .....	7
Figure 2: A1035-D tray specification (1).....	9
Figure 3: A1035-D tray specification (2).....	10
Figure 4: Recommended minimum configuration A1035-D.....	11
Figure 5: Mechanical outline overview A1035-D (bottom).....	13
Figure 6: Mechanical outline overview A1035-D (top).....	14
Figure 7: Mechanical outline overview A1035-D (side A).....	15
Figure 8: Mechanical outline overview A1035-D (side B).....	15
Figure 9: Pin out information A1035-D (bottom and top view).....	16
Figure 10: Application note: External reset circuit.....	23
Figure 11: Demonstration kit DKS1035-D (identical to DKS1035-C shown here) ..	24