

## **INSTRUCTIONS FOR USE**

Introduction .....	2
Indications for Use .....	2
Contraindications .....	2
Caution.....	3
Freedom60 Pump Diagram.....	4
Freedom60 Product Line .....	4
Syringes for Use with Freedom60.....	5
Testing Freedom60 Prior to Use.....	5
Syringe Load/Remove Instructions.....	6
Administering Antibiotics.....	6
Troubleshooting .....	8
Care and Maintenance.....	9
Freedom60 Flow Profile.....	12
Technical Specifications .....	12
Warranty Information .....	13
Definition of Symbols .....	15

## Introduction:

The Freedom60® Syringe Infusion System is portable and easy to use requiring no batteries or electric. There are only two operating knobs and special precision tubing sets are used to control the flow rate.

The Freedom60 operates at a constant safe pressure of 13.5psi. The constant pressure developed in the Freedom60 automatically decreases the flow rate if there is an increase in resistance during the delivery. The system will find equilibrium between the increasing resistance and flow rate. It provides constant flow which tends to inhibit clots, and holds full pressure after an infusion is complete to prevent blood or drug backflow. The Freedom60 also eliminates concerns of a bolus, overflow, overdose or runaway infusion.











## Indications for Use:

The Freedom60 Syringe Infusion System is indicated for the infusion of prescribed liquid medicines.

## Contraindications:

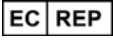
The Freedom60 is not intended for the delivery of whole blood, critical or life sustaining medications, or for the infusion of insulin.

## Definition of symbols:

	On		Manufacturer
<b>OFF</b>	Off		Quantity
	Caution, consult accompanying documents		Catalog number
	Consult instructions for use		Do not reuse
	Authorized representative in the European Community		Serial number
	Use by YYYY-MM-DD or YYYY-MM		Sterilized using irradiation
	Batch code		

 RMS UK Ltd,  
28 Trinity Rd,  
Nailsea, Somerset  
BS48 4NU, UK

 RMS Medical Products  
24 Carpenter Rd.  
Chester, NY 10918 USA  
Ph. 800-624-9600 • 845-469-2042  
www.rmsmedicalproducts.com



[WWW.FREEDOM60.COM](http://WWW.FREEDOM60.COM)

 0297

Patent No. 398,053  
337125 Rev C

- **Warranty Performance Procedure:** Notice of the defect must be made in writing to Customer Support Department, RMS Medical Products/Repro-Med Systems, Inc., 24 Carpenter Road, Chester, NY 10918, USA. Notice to RMS Medical Products/Repro-Med Systems, Inc. must include the model and serial number, date of purchase, and description of the defect in sufficient detail to facilitate repairs. Authorization must be obtained by the Original Purchaser from the Manufacturer or Manufacturers Representative prior to returning the product to the Manufacturer. The defective pump must be properly packaged and returned to the Manufacturer, postage-prepaid. Any loss or damage during shipment is at the risk of the Original Purchaser.
- **Conditions of Warranty:** This warranty does not apply to any product, or part thereof, which has been repaired or altered outside of the Manufacturer's facility in a way so as, in Manufacturer's judgment, to affect its stability or reliability, or which has been subjected to misuse, negligence or accident. Misuse includes, but is not limited to, use without compliance with the device operating instructions or use with non-approved accessories or disposable items.
- **Limitations and Exclusions:** Repair or replacement of an infusion pump or component part is the EXCLUSIVE remedy offered by the Manufacturer. The following exclusions and limitations shall apply:
  - No agent, representative, or employee of the Manufacturer has authority to bind the Manufacturer to any representation or warranty, expressed or implied, or to change this limited warranty in any way.
  - THIS LIMITED WARRANTY IS IN LIEU OF ALL OTHER WARRANTIES, EXPRESS OR IMPLIED, INCLUDING, BUT NOT LIMITED TO, WARRANTIES OF MERCHANTABILITY AND FITNESS FOR A PARTICULAR PURPOSE. THERE ARE NO WARRANTIES THAT EXTEND BEYOND THE DESCRIPTION ON THE FACE HEREOF.
  - Manufacturer's liability under this Limited Warranty Agreement shall not exceed to special, indirect, or consequential damages.
  - The infusion pump can only be used under the supervision of medical personnel whose skill and judgment determine the suitability of the infusion pump for a particular medical treatment.
  - All recommendations, information, and descriptive literature supplied by the Manufacturer or its agents are believed to be accurate and reliable, but do not constitute warranties.

This warranty and the rights and obligations hereunder, shall be construed under and governed by the laws of the State of NY, USA.



### Caution:

- Use the Freedom60 Syringe Infusion System only for the patient in which the device is prescribed and only for its intended use.
- Use only Freedom60 tubing sets manufactured by RMS Medical Products. Use of any other tubing set will cause the syringe to eject from the pump and eventually cause internal damage to the pump. Use of any other tubing set may also cause over delivery of fluids or medication to the patient.
- Use only recommended 60ml syringes with the Freedom60. Do not use Terumo® syringes.
- Do not use syringes smaller than 60ml. The use of a smaller syringe may cause high pressures unsafe for the patient.
- Before use, carefully inspect the tubing set package. Do not use the tubing set if the package is opened or damaged.
- Do not re-sterilize tubing sets.
- Over use of the slide clamp or storing tubing sets where the slide clamp has been engaged for long periods of time may damage the tubing and affect the infusion rate.
- The black tab that pushes on the syringe plunger operates under high force. Do not place fingers on the black tab or inside the syringe shield at any time. Do not attempt to interfere with the movement of the black tab at any time.
- Carefully inspect the Freedom60 Syringe Infusion Pump before use. Verify its condition and test. If repeated testing indicates the pump is not operating properly or at the appropriate rate of flow, immediately discontinue use.
- Do not attempt to open the pump housing or remove the syringe shield. Do not operate if the syringe shield has been removed.
- Do not attempt to remove the syringe or disconnect the tubing set without first turning the pump OFF and fully winding the large knob clockwise until the black tab has reached the end of its track.
- Discontinue use of a pump that has been damaged, exposed to severe impact, or which has failed to test properly.
- Discontinue use of a pump that has been submerged in fluid. If any fluid is allowed to enter the pump, it should be replaced immediately.
- Do not autoclave the Freedom60. It will melt the ABS plastic and damage the pump.
- Federal law (USA) restricts this device to sale by or on order of a physician.

## Freedom60 Pump Diagram:

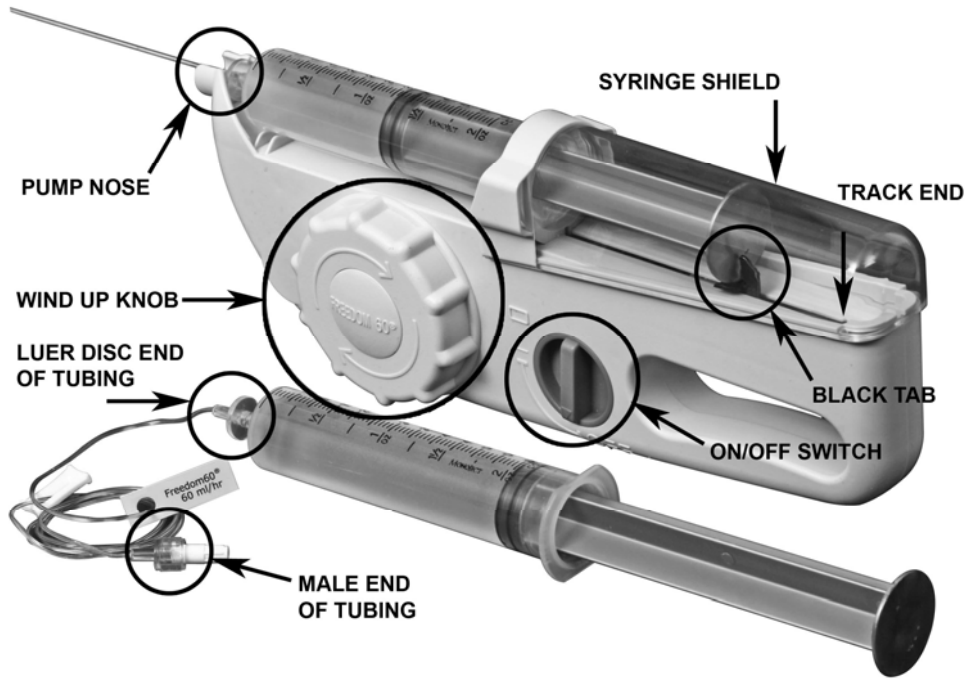

## Freedom60 Product Line:

Each Freedom60 Syringe Infusion System includes a travel pouch and user manual.

Product	Part #
FREEDOM60® Syringe Infusion Pump	F10050
Travel Pouch	F10090

## Rate Controlled Tubing (case of 50)

Flow Rate	Part #	Flow Rate	Part #
0.5ml/hr	F0.5	30ml/hr	F30
1ml/hr	F1	45ml/hr	F45
2ml/hr	F2	60ml/hr	F60
3ml/hr	F3	120ml/hr	F120
3.8ml/hr	F3.8	180ml/hr	F180
5ml/hr	F5	275ml/hr	F275
8ml/hr	F8	600ml/hr	F600
10ml/hr	F10	900ml/hr	F900
15ml/hr	F15	1200ml/hr	F1200
20ml/hr	F20	2400ml/hr	F2400

## Pump:

Weight:	14oz (0.4kg)
Length:	12" (304mm)
Width:	4.5" (114mm)
Height:	1.6" (41mm)

## Rate Controlled Tubing

Length:	6" to 72" (152mm-1829mm)
---------	--------------------------

## Rate Controlled Tubing / Residual Volume (cc's)

F0.5	0.012355555	F30	0.046333332
F1	0.017791999	F45	0.056063332
F2	0.025089499	F60	0.066719998
F3	0.029684221	F120	0.090813331
F3.8	0.033130263	F180	0.066533378
F5	0.038927721	F275	0.043514721
F8	0.03902811	F600	0.019865416
F10	0.031222488	F900	0.01336974
F15	0.065787849	F1200	0.01009037
F20	TBD	F2400	TBD

## Warranty Information:

**Limited Warranty:** RMS Medical Products/Repro-Med Systems, Inc. ("Manufacturer") warrants the infusion pump to be free from defects in materials and workmanship under normal use, if used in accordance with device operating instructions. Warranty is limited to Original Purchaser for one year from date of purchase. The "Original Purchaser" is the person purchasing the infusion pump from the Manufacturer or Manufacturers Representative. Warranty does not extend to subsequent purchasers. Subject to the conditions of and upon compliance with the procedures set forth in this limited warranty, the Manufacturer will repair or replace, at its option, any infusion pump, or part thereof, which has been actually received by the Manufacturer or Manufacturers Representative within the one year warranty period, and which examination discloses, to the Manufacturer's satisfaction, that the product is defective. Replacement product and parts are warranted only for the remaining portion of the original one-year warranty period. This warranty does not apply to accessories and disposable items.

The following conditions, procedures, and limitations apply to the Manufacturer's obligations under this warranty:

- **Parties Covered by this Warranty:** This warranty extends only to the Original Purchaser of the infusion pump. This warranty does not extend to subsequent purchasers.

## Freedom60 Flow Profile:

The Freedom60 flow profile shows that the flow rate is consistent throughout the delivery of medication.

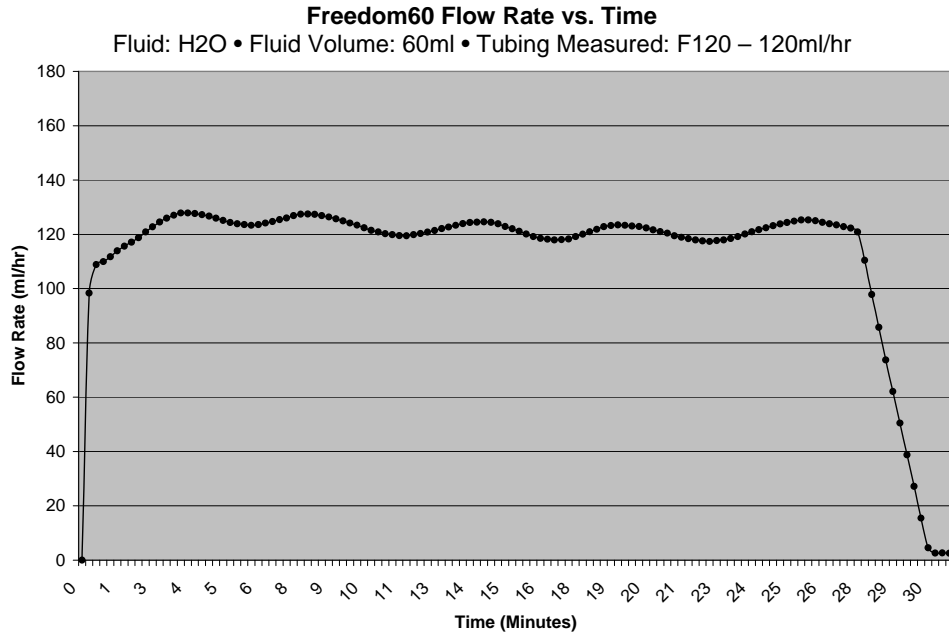

## Technical Specifications:

### System:

Reservoir volume:	60ml (maximum)
Residual volume:	<0.4ml
Flow rate accuracy:	+/- 8%*
Operating pressure:	15psi (maximum)
Height sensitivity:	+/- 3% per 12" (30cm)
Constant force mechanism:	+/- 3%

\*Flow rate data recorded at 22°C using 60ml of 0.9% NS. An overall accuracy of +/-8% is expected at these values. At higher temperatures, which results in a decrease in viscosity, a higher flow rate is anticipated to occur. The flow rate variation due to changes in temperature is approximately linear and would vary from -20% at 14°C to +20% at 30°C. Fluids considerably more viscous than 0.9% NS are expected to slow the flow rate and consequently may result in longer infusion times. More viscous fluids may be tested before patient use by following the bench test procedures described in this manual.

**Note:** Colors have been added to certain flow rates in order to identify those most commonly used for antibiotics. They are used only to identify them as most common and can be used to help aid in the selection of rates when there are multiple rates present. They do not bear any other meaning or change the performance in any way. (F15=Orange, F20=Purple, F30=Red, F45=Teal, F60=Green, F120=Blue)

## Syringes for use with the Freedom60:

- Becton Dickinson & Co. BD® Luer-Lok® 60ml (US Reference #309653; EU Reference #300865)
- Sherwood Medical Monoject® 60ml (Reference #8881-560125)

## Testing the Freedom60 Syringe Infusion Pump:

1. Examine the inside of the syringe shield and ensure it is free of debris or contamination.
2. Make sure that the pump's on/off switch is in the OFF position and that the black tab within the syringe shield is at the end of its track. If the black tab is not at the end of its track, fully wind the large knob clockwise.
3. Turn the pump ON (–) and watch that the tab moves smoothly the full length of its track; listen for the following sounds:
  - a “click” as the pump is turned ON (–),
  - a “whirling” sound as the black tab moves forward,
  - a “click” as the tab reaches the end of its travel.
4. Test to make sure the syringe tension-tab (the one-inch long, tab located at the entry of the syringe shield) operates freely by adjusting it up and down with your finger.

## Syringe Load and Remove Instructions:

### Step 1

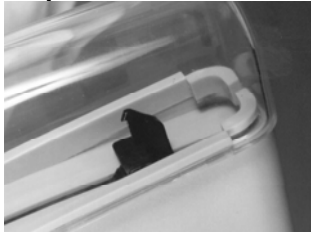

Make sure that the pump's on/off switch is in the OFF position and that the black tab within the syringe shield is at the end of its track. If the black tab is not at the end of its track, wind the large knob clockwise.

### Step 2

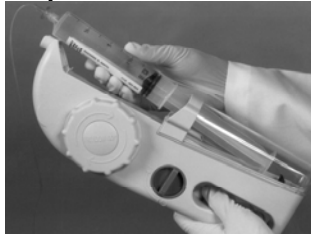

Load the prefilled syringe; tubing attached, with gradations facing up, plunger first into the syringe shield. Make sure the tubing luer disc is fully seated in the pump's nose.

### Step 3

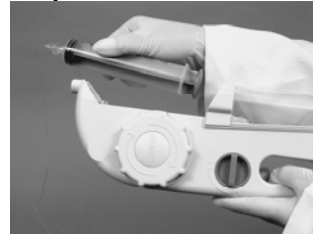

After the infusion is complete, turn the pump OFF and wind the large knob clockwise until the black tab is at the end of its track. Remove the empty syringe by gently pushing it back and up out of the pump.

**Note:** You will never need to use force to load or remove a syringe. If you're having trouble loading or removing, stop and make sure the black tab is at the end of its track.

## Administering Antibiotics:

**Note:** The chart below is intended for drugs with low viscosity. DO NOT use this chart for IgG, desferal or other viscous fluids. Drugs with greater viscosity will flow significantly slower and can be compensated for by using a faster flow rate tubing set. To assist you in determining what flow rate tubing set is to be used with these drugs, please contact us at 1-800-624-9600. Again, the chart below is for drugs with low viscosity only.

	60ml/hr Tubing	120ml/hr Tubing
Best Test Rate	72	134
Less Clinical Effects		
Catheter Gauge (20G PICC)	-7	-8
Fluid Viscosity (D5W)	-2	-3
Venous Pressure	-3	-3
Label Flow Rate	60	120

2. To assure consistent test results, keep pump and tubing at the same approximate horizontal plane and monitor flow for a minimum of 20 minutes. The Freedom60 System is factory rated to deliver infusions under strict test conditions over a large number of pumps tested within 8% of nominal with a 95% statistical confidence interval. Under varying bench test and fluid conditions this range can be expected to vary approximately 15% of nominal. For more accurate monitoring, use a stopwatch and finely graduated burette. Freedom60 pump testing is based on ANSI/AAMI National Standard, ID 26-1992, Infusion Devices, August 24, 1992.

If test results in the range indicated cannot be approximated under bench testing conditions, factory refurbishment and full certification testing is available from the manufacturer.

### References:

1. Stuhmeier, Mainzer B. MD; Aspects of pressure build-up in the use of electronic infusion devices. II. Need for a pressure limit. Ansth Intensivther Notfallmed (1987 Aug.) 22(4): 185-190.
2. Ansth Intensivther Notfallmed (1987 Aug.) 22(4): 181-184. ANSI/AAMI National Standard, ID 26-1992, Infusion Devices, August 24, 1992.

If absolutely necessary, you may clean the inside of the syringe shield by using a long swab or bottlebrush and any cleaning agent compatible with ABS and PC plastics. Alcohol is not recommended.

**Storage:**

Store the Freedom60 pump in a cool dry place and packaged tubing sets at room temperature (approximately 16-30C or 61-86F).

**Testing Flow Accuracy (if required by your local protocol):**

1. Fill a new syringe with 60ml of sterile water
2. Remove all air from the syringe
3. Attach a sterile Freedom60 tubing set to the syringe
4. Remove all air from the tubing set
5. Load the syringe into the pump and turn the pump ON (-)
6. Monitor the syringe readings and elapsed time to derive an approximate flow rate.
7. Compare your test results to the range of test rates listed in the table below:

Labeled Flow Rate	Bench-Rated Flow Rate (1)	Test Range (2)
60ml/hr	72ml/hr	61-83ml/hr
120ml/hr	134ml/hr	113-154ml/hr

1. The Freedom60 Infusion Pump design accounts for the effects of standard clinical conditions on flow rate performance. Under bench test conditions, a 60ml/hr labeled tubing set is designed to generate a nominal infusion rate of 72 milliliters per hour. A 120ml/hr labeled tubing set will generate a nominal bench test rate of 134 milliliters per hour. The Freedom60 generates nominal bench test rates higher than the labeled rate accounting for the following standardized application criteria that affects actual delivery rates under normal clinical circumstances.

Freedom60® Rate Controlled Tubing Sterile Water for Infusion (SWFI) Flow Rate – Time Chart						
Syringe Volume	F1	F2	F30	F45	F60	F120
5	5 hrs.	2 hrs. 30 min.	10 min.	6 min. 42 sec.	5 min.	2 min. 30 sec.
10	10 hrs.	5 hrs.	20 min.	13 min. 18 sec.	10 min.	5 min.
15	15 hrs.	7 hrs. 30 min.	30 min.	20 min.	15 min.	7 min. 30 sec.
20	20 hrs.	10 hrs.	40 min.	26 min. 42 sec.	20 min.	10 min.
25	25 hrs.	12 hrs. 30 min.	50 min.	33 min. 18 sec.	25 min.	12 min. 30 sec.
30	30 hrs.	15 hrs.	60 min.	40 min.	30 min.	15 min.
35	35 hrs.	17 hrs. 30 min.	70 min.	46 min. 42 sec.	35 min.	17 min. 30 sec.
40	40 hrs.	20 hrs.	80 min.	53 min. 18 sec.	40 min.	20 min.
45	45 hrs.	22 hrs. 30 min.	90 min.	60 min.	45 min.	22 min. 30 sec.
50	50 hrs.	25 hrs.	100 min.	66 min. 42 sec.	50 min.	25 min.
55	55 hrs.	27 hrs. 30 min.	110 min.	73 min. 18 sec.	55 min.	27 min. 30 sec.
60	60 hrs.	30 hrs.	120 min.	80 min.	60 min.	30 min.

**Starting the Infusion**

Before loading the syringe verify the following:

- Make sure that the pump's on/off switch is in the OFF position.
- Make sure that the black tab inside the syringe shield is at the end of its track. If the black tab is not at the end of its track, wind the large knob clockwise.
- Verify that you have the correct rate controlled tubing set.

1. Using sterile technique, remove the sterile cap from the luer disc end of the rate controlled tubing set and connect to the pre-filled syringe.
2. With syringe gradations facing up, insert the syringe, plunger first into the syringe shield. Make sure the luer disc is fully seated in the pump's nose.

**Note:** You will never need to use force to load or remove a syringe. If you are having trouble loading/removing make sure the pump is in the OFF position and that the black tab is at the end of its track. If the black tab is not at the end of its track, fully wind the large knob clockwise.

3. Using sterile technique, prime the tubing with the pump by loosening the cap on the male end and turning the pump ON (-). You will immediately hear a “whirling” sound as the black tab searches for the syringe plunger. When the tab finds the plunger it will “click” indicating that that the tab is now applying pressure

onto the plunger. Medication is now being pumped through the tubing set. When all air and air bubbles are gone and medication starts to drip, tighten the cap.

4. Remove the cap from the male end of the tubing and connect the tubing to the patient's indwelling needle or catheter.
5. Turn the pump on to begin the infusion.

**Note:** Once the black tab finds the syringe plunger and the "click" sound is heard, the pump will then be totally silent for the entire infusion.

### Checking Infusion Progress

Periodically check infusion progress by taking note of the time the infusion started and checking movement of the syringe plunger. The approximate rate for antibiotics or other non-viscous solutions can be found on the waterproof label attached to the tubing. (i.e. F60 will flow at 60ml/hr; F30 will flow at 30ml/hr etc.)

### End of Infusion

1. Confirm that the syringe is empty.
2. Turn the pump OFF and wind the large knob clockwise until the black tab is at the end of its track.
3. Disconnect the tubing from the patient.
4. Gently lift the syringe back and up out of the pump.

**Note:** If the dose is greater than 60ml and an additional syringe is required, load the additional syringe by repeating section titled, "Starting the Infusion."

### Troubleshooting:

If the suggestions in this section do not solve your problem, or if problems persist, discontinue use and consult our office and/or your medical provider.

#### Syringe will not load or remove from pump

You will never need to use force to load or remove a syringe. Make sure the pump is in the OFF position and that the black tab is at the end of its track. If the black tab is not at the end of its track, fully wind the large knob clockwise and try again.

#### Syringe will not stay inside in the pump

- Make sure you are using the proprietary Freedom60 rate controlled tubing sets with the luer disc.
- Make sure the luer disc end of the tubing has been connected to a 60ml syringe and that it is seated properly in the nose of the pump.

#### No flow

- Assure that the pump is in the ON (–) position.
- Make sure the slide clamp is unclamped, or has not been used for an extensive period of time. If the slide clamp is overused it can damage the tubing.

- Test the tubing: While the pump is in the ON (–) position, use sterile procedures to disconnect the rate controlled tubing set from the indwelling needle or catheter; check for medication drip. If medication does not drip, replace the tubing as it may be blocked or damaged. If medication does drip from the rate controlled tubing, then it's most likely a problem with the indwelling needle or catheter.

#### Slow flow

- If a slide clamp is used for an extensive period of time, it can damage the tubing and affect the flow rate. Try using another tubing set and measure the flow. For 60ml/hr tubing, the syringe plunger should move 10mls in 10 minutes (1ml per minute). For 120ml/hr tubing, the plunger should move 10mls in 5 minutes (2mls per minute).

#### Continuous flow even when the pump is turned OFF

This is a normal function of the pump. The pump is designed to maintain pressure during and after the infusion to prevent blood/drug backflow. To stop the flow turn the pump OFF and wind the large knob clockwise so the black tab moves away from the syringe. This will release pressure on the plunger. You can also use the slide clamp. We recommend only using the slide clamp to immediately stop the flow in the case of an emergency. Overuse can damage the tubing.

#### Medication (5ml or less) left in the syringe

- Verify that you are using the proper BD or Monoject brand 60ml syringe. Do not use Terumo syringes.

### Care and Maintenance:

The Freedom60 does not require any preventative maintenance. The Freedom60 works as a system, which means the tubing determines the flow rate, not the pump; therefore our pump needs no calibration. If you choose the correct tubing set the proper flow rate will be achieved. Our tubing sets are statistically verified during manufacture and will deliver the appropriate flow rate under controlled conditions.

#### Cleaning:

Clean only those areas that are exposed and external. No attempt should be made to clean any part of the pump that is not easily accessible. Discontinue use of a pump that has been internally exposed to or immersed in fluid.

Wipe the surface with warm water and detergent or use any surface disinfectant compatible with acetyl-butyl-styrene (ABS) and polycarbonate (PC) plastics, such as household bleach or hydrogen peroxide. Avoid the use of alcohol or alcohol containing compounds, as these tend to make ABS plastic brittle. Wipe again with clean water to rinse.