

LITEMAX LD1946

Sunlight Readable 19" LCD Display

(1st Edition 2/25/2005)

All information is subject to change without notice.

LITEMAX Electronics Inc.

4F, No.131-3, Lane235, Bau-chiau Rd.,
Shin-dian City, Taipei County, Taiwan R.O.C.

Tel : 886-2-8919-1858

Fax: 886-2-8919-1300

Homepage: <http://www.litemax.com.tw>

Content

Introduction	3
Hardware Installation.....	3
The Display Timing.....	5
The Display Outline Dimensions	6
The Display Controls	7
The Screen Adjustment.....	8
Troubleshooting Tips	10
Specification.....	11
Product Safety Precautions.....	12

Introduction

Welcome to enjoy the fantastic sightseeing world. This new technology will bring you the whole new feeling about the "monitor". We show here some of the major advantages of the LCD monitor. You will really find some other advantages when you use it.

Hardware Installation

This chapter will guide you the correct installation procedures of your LCD monitor.

Unpacking

After you unpack your LCD Monitor, please make sure that the following items are included in the carton and in good condition. If you find that any of these items are damaged or missing, please contact your dealer immediately.

- One LCD Monitor
- 15-pin D-sub Video cable (Option)
- AC/DC adapter with 12V DC output (Option)
- AC power cord (Option)
- Quick installation Guide

Installation

This analog LCD display **does not** require any special drivers. Necessary drivers are supplied by the video card manufacturer and may be found on the diskettes supplied with the video card that came with your computer. Windows 98/2000/XP drivers for both the display and the video card are supplied on the Windows 98/2000/XP CD or diskettes. Unfortunately, Microsoft did not provide a complete listing of the displays on the initial retail release. You may use the standard SXGA (1280x1024) as the display type. The video card must also be set up correctly in Windows 98/2000/XP and make sure the video output of the VGA card is on list in Section 6.1 or check your Video Card manual or Windows 98/2000/XP Read me file for further information on Video Card. After the question listed above is solved, we continue the setup procedure as below.

1. Turn power off both Computer and Display before making any connection.
2. Install Display on the solid horizontal surface such as a table or desk.
3. Connect the power cable and the AC/DC adapter, then connect adapter to the back of the LCD monitor.
4. The LCD monitor comes with a 15-pin video cable; you may use this cable for both IBM PC's & compatibles and Macintosh.
5. Tighten the screws of the Display cable until the connectors are fastened securely.
6. Switch on power to the Computer system, then to the monitor.

The following picture provides the connection outline

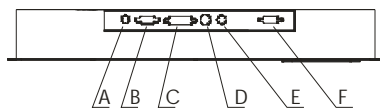
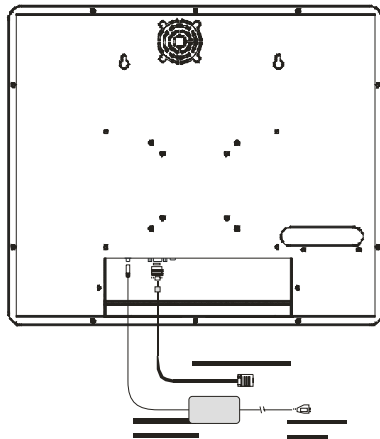

- A: POWER
- B: VGA INPUT
- C: DVI INPUT
- D: S-VIDEO INF
- E: AV INPUT
- F: TOUCH INPUT

Video Input Pin Assignment

This section describes the pin assignment of the LCD's video connector. It is called 15pin Mini D-sub connector.

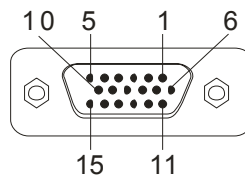

Pin No.	Signal Connector
1	Red Video Signal
2	Green Video Signal
3	Blue Video Signal
4	N.C.
5	Ground
6	Ground for red video signal
7	Ground for green video signal
8	Ground for blue video signal
9	N.C.
10	Ground
11	N.C.
12	DDC data
13	Horizontal sync signal
14	Vertical sync signal
15	DDC clock

The Display Timing

Applicable video timing

The following table lists the better display quality modes that the LCD monitor provides. If the other video modes are input, the monitor will stop working or display unsatisfactory picture quality.

VESA Modes					
Mode	Resolution	Total	Nominal Frequency ±0.5KHz	Nominal Frequency ±0.5KHz	Nominal Pixel Clock (MHz)
DOS	720x400@70Hz	900x449	31.469	70.087	28.322
VGA	640x480@60Hz	800x525	31.469	59.940	25.175
	640x480@72Hz	832x520	37.861	72.809	31.500
	640x480@75Hz	840x500	37.500	75.000	31.500
SVGA	800x600@56Hz	1024x625	35.156	56.250	36.000
	800x600@60Hz	1056x628	37.879	60.017	40.000
	800x600@72Hz	1040x666	48.077	72.188	50.000
	800x600@75Hz	1056x625	46.875	75.000	49.500
XGA	1024x768@60Hz	1344x804	48.363	60.004	65.000
	1024x768@70Hz	1328x806	56.476	70.069	75.000
	1024x768@75Hz	1312x800	60.023	75.029	78.750
SXGA	1280x1024@75Hz				
IBM Modes					
EGA	640x350@70Hz	800x449	31.469	70.086	25.175
DOS	720x400@70Hz	900x449	31.469	70.087	28.322
VGA	640x480@60Hz	800x525	31.469	75.000	31.500
XGA	1024x768@72Hz	1304x798	57.515	72.100	75.000
SXGA	1280x1024@75Hz				
MAC Modes					
VGA	640x480@60Hz	800x525	31.469	59.940	25.175
SVGA	832x624@75Hz	1152x667	49.725	74.551	57.2832
XGA	1024x768@75Hz	1328x804	60.927	74.927	80.000
SXGA	1280x1024@75Hz				

The Display Outline Dimensions

Unit: mm

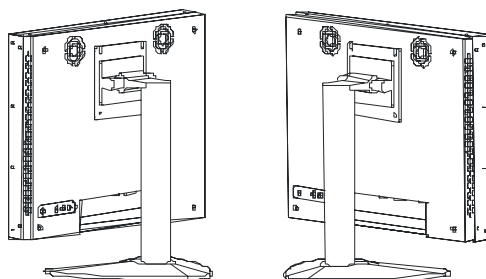
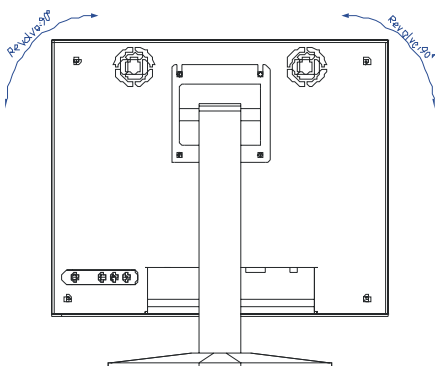
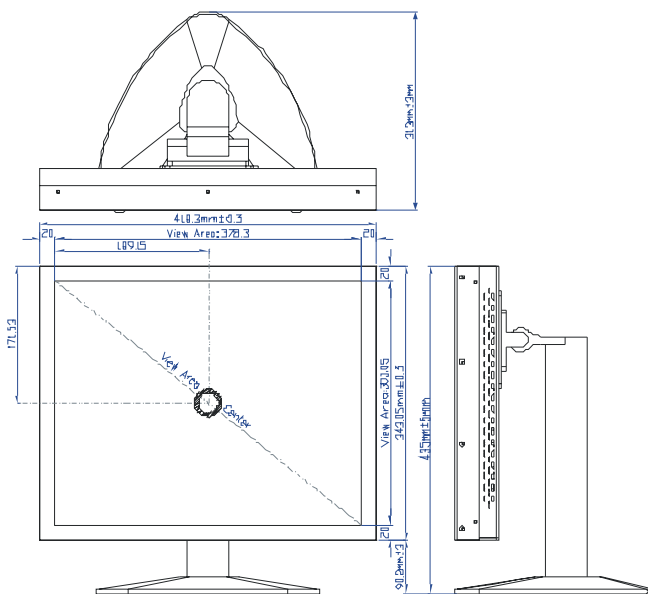

Membrane Control Button

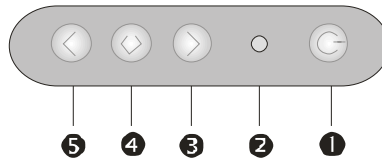

- ❶ **POWER SWITCH:** Pushing the power switch will turn the monitor on. Pushing it again to turn the monitor off.
- ❷ **Power LED:** Power ON-Green / Power off-No.
- ❸ **Up Key >:** Increase item number or value of the selected item.
- ❹ **Menu Key:** Enter to the OSD adjustment menu. It also used for go back to previous menu for sub-menu, and the change data don't save to memory.
- ❺ **Down Key <:** Decrease item number or item value when OSD is on. When OSD is off, it is hot key for input switch between VGA, AV, and S-video.

Screen Adjustment Operation Procedure

1. **Entering the screen adjustment**
The setting switches are normally at stand-by. Push the **Menu Key** once to display the main menu of the screen adjustment. The adjustable items will be displayed in the main menu.
2. **Entering the settings**
Use the **Down Key <** and **Up Key >** buttons to select the desired setting icon and push the SELECT button to enter sub-menu.
3. **Change the settings**
After the sub-menu appears, use the **Down Key <** and **Up Key >** buttons to change the setting values.
4. **Save**
After finishing the adjustment, push the SELECT button to memorize the setting.
5. **Return & Exit the main menu**
Exit the screen adjustment; push the "MENU" button. When no operation is done around 30 sec (default OSD timeout), it goes back to the stand-by mode and no more switching is accepted except MENU to restart the setting.

The Screen Adjustment







Main Menu

You can adjust the brightness, contrast, display colors, the horizontal and vertical position of the display and OSD menu, etc. through the main menu display.

The **Down Key <** and **Up Key >** are used to scroll through items within the menu. The selected item is highlighted as the scrolling move along. The **SELECT** key is used to activate the highlighted item. During this state, **MENU** key is used to close the OSD menu from the screen.



Menu key function:

	Color	Setup the contrast, brightness and color of the panel. / The Contrast menu item is used to adjust image contrast.
	Picture	Setup the image position within the panel.
	Function	Select auto adjust & auto color function can make the monitor have the best efficiency.
	OSD	There many languages can be selected and setup OSD position
	Miscellaneous	You can set signal source, mode select, and volume and restart the setting.
	Exit	Exit setting.

Troubleshooting Tips

In the event that you experience trouble with your Display, check the following items before contacting the dealer from whom the Display was purchased. The most common problems usually involve an incorrectly an incorrect connection from the Video Card to the Display. We recommend that you also consult your Video Card User's manual during the Troubleshooting Procedure. Do not exceed the maximum refresh rate recommended for the display.

Problem	Troubleshooting Tip
No image on display screen	<ol style="list-style-type: none">1. Check that power cord of the Computer has been connected securely into wall outlet or grounded extension cable or strip.2. Check that power switch of the Display has been pressed and LED on the front of Display is lit.3. Check that Video (Signal) cable from the Display has been securely and correctly connected.4. Check that Video Card is firmly seated in card slot of Computer motherboard.5. Check that the video input from the Video Card falls within the timing range.
Abnormal image	<ol style="list-style-type: none">1. Check that the video input from the Video Card falls within the timing range.2. Check that Video (Signal) Cable from the Display has been securely and correctly connected to the Video Connector at the rear side of the Computer.
Colors of image on screen are abnormal	<ol style="list-style-type: none">1. Check that Video (Signal) Cable from the displays has been securely and correctly connected to the 15-pin Video Connector at the rear side of the computer.
Disturbances on Screen	<ol style="list-style-type: none">1. OSD adjustment is incorrect. Please consult section for OSD screen adjustment procedures.

Please contact your local authorized distributors /retailers if you run into other unsolved problems.

LCD Specification

Model No.	LD1946
Manufacturer	AUO
Manufacturing Country	Taiwan/ China
ID no	M190EN03
Display surface	Non-glare hard coated
Number of colors	8 bit
backlight	12 CCFL
Interface	2 ch LVDS
Uniformity	75% (Min)
Display Area	378.3 x 303.05mm
LCD Display	15" TFT active matrix
Display Colors	262,144 Colors
Luminance	600 cd/m ² (Center) (analog circuit without any visualization without touch)
Contrast Ratio	800 :1 (typ.)
Resolution	1280 x 1024 (sXGA)
Pixel Arrangement	RGB (Red, Green, Blue) vertical stripe
Pixel Pitch	0.3(H) x 0.3(V)
Viewing Angle	+85°~-85° (H), +85°~-85° (V)
Color saturation	72%
Color Gamut	At LCD panel center 60% (typ.) [against NTSC color space] Ton (black 10%→white 90%)
Response Time	20 ms (typ.)
Signal Connector	15 Pin D-sub, 29 Pin DVI-D
F/R Control Button	Power Switch, Menu, Select (+,-), Auto
OSD Menu	Brightness, Contrast, H/V Position, Color, Phase, Clock, Language, Management
Power Consumption	At maximum luminance and checkered flag pattern 80W (Max.)
Module Size	418.3 (W) x 435 (H) x 313(D)mm
Weight (Net)	15 kg (Approx.)
Option	Touch (Resistive/ Capacitive),Light Sensor, VR Control
Certification	CE, FCC

Specifications subject to change without notice.

● MTBF of LCD

After 15,000 hours operation and 100,000 switching cycles the brightness is still more than 50% of the original brightness.

Product Safety Precautions

Follow all warnings and instructions marked on the product.

Do not use this product near water.

This display should be installed on a solid horizontal base.

When cleaning, use only a neutral detergent cleaner with a soft damp cloth. Do not spray with liquid or aerosol cleaners.

Do not expose this display to direct sunlight or heat. Hot air may cause damage to the cabinet and other parts.

Adequate ventilation must be maintained to ensure reliable and continued operation and to protect the display from overheating. Do not block ventilation slots and openings with objects or install the display in a place where ventilation may be hindered.

This display should be operated from the type of power source indicated on the AC/DC adapter.

Do not install this display near a motor or transformer where strong magnetism is generated. Images on the display will become distorted and the color irregular.

Do not allow metal pieces or objects of any kind fall into the display from ventilation holes.

Do not attempt to service this unit yourself. Removal of the display cover may expose you to dangerous voltage or other risks. Refer all servicing to qualified service personnel.

Unplug this product from the wall outlet and refer servicing to qualified service personnel in the event that:

1. Liquid is spilled into the product or the product is exposed to rain or water.
2. The product does not operate normally when the operating instructions are followed.
3. The product has been dropped or the cabinet has been damaged.
4. The product exhibits a distinct change in performance, indicating a need for service.
5. Power cord or plug is damaged or frayed.

General specifications for the LCD

The following items are neither defects nor failures.

- Response time, luminance and color gamut may be changed by ambient temperature.
- The LCD may be seemed luminance uniformity, flicker, vertical seam and/or small spot by display patterns.
- Optical characteristics (e.g. luminance, display uniformity, etc.) gradually is going to change depending on operating time, and especially low temperature, because the LCD has cold cathode fluorescent lamps.