

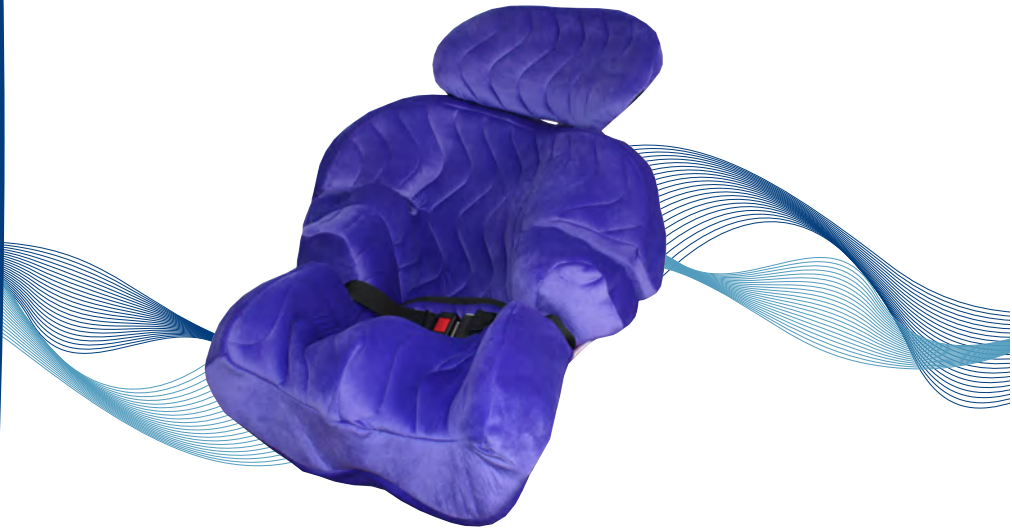

Specialised
Orthotic
Services

Foam Cast Seat



USER'S MANUAL

ALL USER'S OF THE EQUIPMENT SHOULD BE AWARE
OF THIS DOCUMENT AND ITS CONTENT

Index

CONTENTS	PAGE
Specification of Seating System	1
Index	2
Introduction	3
Clinical Review	4
Stability of Wheelchair and Seating Systems	4 & 5
Recommendations on Transport	5 - 8
1.0 <u>User’s Guide “Fitting the Foam Cast Seat to the wheelchair”</u>	
1.1 Locating the Foam Cast Seat Frame	9 - 11
1.2 Foam Cast Seat Cover	12
1.3 Electric Wheelchair Use	12
1.4 Maintaining the Wheelchair	12
2.0 <u>User’s Guide “Lifting and Handling the Client”</u>	
2.1 Lifting and Handling the Client in and out of the seat	13
2.2 Client Straps, Harnesses	13
2.3 Footrest Adjustment	13
3.0 <u>User’s Guide “Maintenance of the Foam Cast Seat”</u>	
3.1 Cleaning the Foam Cast Seat	14
3.2 Cleaning the Foam Cast Seat Cover	14
3.3 Harness, Pads & Straps	15
3.4 Visual Inspection	15
3.5 Fire Retardancy	15
4.0 <u>User’s Guide “Optional Features”</u>	
4.1 Adjustable Headrest	16
4.2 Adjustable Footrest	16 & 17
4.3 Detachable Pommel	17
If You Detect a Fault or Breakage	18
CONTACT DETAILS	Backpage

FOAM CAST SEAT

(Custom Made Device)

Introduction

- This Users Guide for the Foam Cast Seat is designed to give guidance on its use and maintenance.
- The Foam Cast Seat is custom made to suit an individual clients postural requirements.
- Each Foam Cast Seat is manufactured for a particular individual and ***must not be used to seat anyone else.***
- The Foam Cast Seat gives overall postural support so the clients weight is evenly distributed over a large area. This improves comfort and should improve overall tolerance in the seated position.
- The Foam Cast Seat is also manufactured for use with a particular wheelchair or buggy. To make sure that placing the Foam Cast Seat in the wheelchair does not render it unstable, each Seat supplied is tested for stability and a Certificate of Compliance is issued to verify that the level of stability is satisfactory (for more details regarding stability of wheelchair & seating systems, see page 4).
- It is recommended that initial use of the Foam Cast Seat by the client after hand over is closely monitored for the first few days. Particular attention should be given to checking the client for any signs of pressure areas, which appear to be caused by sitting in the Seat. If there is any indication of any abnormal pressure areas then refer the client back to the Special Seating Clinic as soon as possible. If the incidence of pressure is very severe then it is recommended that the client stops using the Seat until this can be assessed back at the Seating Clinic.
- It is recommended that the amount of time a client sits in the Foam Cast Seat is controlled, this will vary due to circumstances, but where possible periods of sitting in the Seat should not exceed more than 3 hours at a time. Removing the client from the Seat is advised after such a period to offer a change of posture. By doing this you will improve a clients tolerance to sitting in the Seat on a daily basis.
- The maintenance and safety instructions described in the manual must be adhered to. By following these instructions you will be ensuring correct use of the Foam Cast Seat and its safety in use.
- It is also important to read the 'Wheelchair User Manual' with regard to general use, transportation use and maintenance.

Clinical Review

- To ensure that the Foam Cast Seat still meets the clinical requirement of the client, it is recommended that the Seat is reviewed by the Special Seating Clinic at least once a year.
- This may be done automatically by your Wheelchair Service.
- If a client has had an Foam Cast Seat over twelve months it is recommended that you contact the Wheelchair Service for a review. This will ensure that the Seat is maintaining the clinical needs of the client.
- If you feel that the client needs to be assessed with regard to any seating needs, then contact your Wheelchair Service.

Stability of Wheelchair and Seating Systems

- To ensure that the Foam Cast Seat and wheelchair are safe to use, it is important that fitting the Seat to the wheelchair does not make the wheelchair unstable during normal daily use. Each Seat when handed over to the user will be tested for stability to the relevant angle of stability for the chair to be tested.
- The recommended maximum angle of tilt is 12° for attendant transit wheelchairs and 16° for users of self propelling wheelchairs and 16° for users of electric indoor and electric outdoor wheelchairs.
- If the client is going to use additional items mounted to the wheelchair or seating system such as communications aids etc., then it is essential that the test be done with these in situ to access their impact on the safety of the wheelchair. Similarly, simple items such as trays need to be in place for the test to take into account all the equipment to be used by the client (see diagram opposite).
- The stability test is always done with the client seated in the seating system and all equipment to be used by the client on a daily basis when in the wheelchair in situ. The combined client Seating System and wheelchair assembly is tested to the specified maximum angle of tilt.
- Once the test has been successfully completed, a Stability Certificate will be issued by Specialised Orthotic Services Limited. A copy of this certificate will be handed over when the equipment is supplied and should be kept with the user manual for future reference.

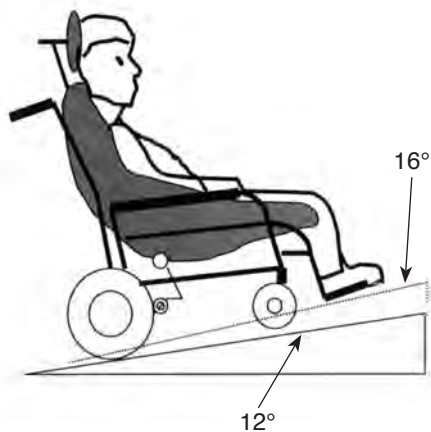

Stability of Wheelchair and Seating Systems (Cont.)

- The *Foam Cast Seat* is not to be used with any other wheelchair(s) than those for which it has been stability tested and proven safe for use.
- Always steer clear of obstacles where possible.
- When using the equipment never attempt to climb or descend an incline where the surface is rough, wet or slippery (gravel, loose chippings, grass, rain, ice, snow, etc).
- If the equipment is to be used in an electric wheelchair then read carefully the wheelchair manufacturers instructions with regard to safety.
- ***WARNING:*** Whilst the client is seated in the wheelchair, the attachment of any heavy object to the wheelchair (i.e. shopping bags etc.) will have a serious effect on the overall stability of the wheelchair and may place the safety of the client at risk.

Recommendations for the Transportation of SOS Seating Systems

The following information is intended to give guidance with regard to the use of SOS Seating Systems by wheelchair users and carers during transportation.

- ***Specialised Orthotic Services Ltd*** have carried out extensive investigations into the suitability of our Special Seating Systems for transportation use and has established clear guidelines for users.
- Following these investigations the following user information is intended to give guidance to users of SOS Seating Systems regarding the use of the equipment during transportation.
- All SOS Seating Systems are prescribed via Special Seating Clinics and during the assessment process the wheelchair to be used with the Seating System will be identified.
- As part of the assessment process, transportation requirements will be assessed and a suitable wheelchair prescribed for use with the Seating System.

This information will be of interest to all parties involved in the daily management of the wheelchair user (Relatives, Carers, Support Staff, Healthcare Professionals and Transport Service Providers).

General Safety Guidelines for Wheelchair User Transportation

- Wheelchair users should transfer to vehicle seats whenever possible.
- Wheelchair users should not travel with the wheelchair at an angle or facing sideways to the direction of travel.
- There should be sufficient free space around the wheelchair and user to avoid the user making contact with other vehicle occupants, unpadded parts of the vehicle, wheelchair accessories or W.T.O.R.S. anchor points.
- Wheelchairs should have the parking brakes applied and their power units switched off during vehicle movement. Powered wheelchairs should not be left in free wheel mode.
- Wheelchairs should not block gangways and exits for other passengers in the vehicle.
- A headrest should be provided for a wheelchair user when travelling in a vehicle where other seated passengers have headrests.
- Do not place / hang any additional items onto the wheelchair during transportation such as shopping bags and holdalls.
- Trays should be removed for transportation whenever possible. If it is necessary for a tray to be used on transportation, then a risk assessment should be done.

Wheelchair Tie Down and Occupant Restraint System (W.T.O.R.S.)

- Secure methods for the safe retention of wheelchairs have been developed and are used on a regular basis to secure wheelchairs during transportation use.
- These systems are now commonly referred to as **W.T.O.R.S.**

Wheelchair Tie down and Occupant Restraint Systems

- There are many types of W.T.O.R.S. available from various manufacturers (a list of some manufacturers is given on page 8). Refer to your Wheelchair Manufacturers Handbook for details of their particular recommendations.
- Please note that all lap /chest belts and harnesses supplied with the seating system **are not** sufficient for occupant restraint when the equipment is used on a moving vehicle and additional Occupant Restraint is required.

Use of Seating System in a Wheelchair for Transportation

To make sure that the seating system and wheelchair are used effectively and safely for transportation use, the following recommendations are provided for:

- The Seating System - Wheelchair Interface
- The Wheelchair Tie down System
- The Occupant Restraint System

1. WHEELCHAIR TIE DOWN SYSTEM

- **Wheelchair users should not travel in cars, taxis or minibuses, unless the wheelchair is tied down.**
- Please refer to your wheelchair users guide for information regarding the recommended wheelchair tie down system to be used.
- Only the wheelchair specified for use with the seating system can be used.
-

2. OCCUPANT RESTRAINT SYSTEM

- **Wheelchair users should not travel in cars, taxis or minibuses, unless an occupant restraint system is in place on the client.**
- For any client to be transported safely in the Seating System and wheelchair, it is essential that an Occupant Restraint System be used.
- SOS have proven during crash tests on Foam Cast Seats that transporting any client on a moving vehicle without an approved occupant restraint system is extremely dangerous and will place the **client at great risk**.
- It is important that the Occupant Restraint System is positioned correctly as most clients using Special Seating will be dependent on carers for correct placement of the occupant restraint.
- Consideration should be given to the most suitable type and positioning of restraint for the user, both in normal travel and during an impact.
- The Occupant Restraint should have a clear path from the user to the anchor point and should not be interfered with by any part of the vehicle, wheelchair, seating or accessory.

Stowage of the Seating System and Wheelchair

- During use of your Special Seating System it may be necessary for you to remove the Seating System and stow this along with the wheelchair in a vehicle.
- It is **important** to realise that these items pose a **risk** if not adequately restrained whilst in transit.
- It is **not** adequate to simply place the items into a car boot or the floor of an open vehicle such as an MPV or estate car as in a collision these unsecured items could cause **serious injury** to occupants of the vehicle.
- Various retention methods are available to secure such equipment during transit, and once again the list of Wheelchair Restraint System Manufacturers in this booklet will be happy to advise on this matter (see below).

W.T.O.R.S MANUFACTURERS

Below are details of some Wheelchair Tie down and Occupant Restraint Systems manufacturers.

UNWIN SAFETY SYSTEMS

Unwin House
The Horseshoe
Coat Road
Martock
Somerset
TA12 6EY

TEL: 01935 827740
FAX: 01935 827760
E Mail: sales@unwin-safety.co.uk

KOLLER ENGINEERING LTD

Unit 5, Garrett Road
Lynx Trading Estate
Yeovil
Somerset
BA20 2TJ

TEL: 01935 426695
FAX: 01935 433766
E Mail: enquiries@koller.co.uk

QSTRAINT (EUROPE)

Unit 175
John Wilson Business Park
Whitstable
Kent
CT5 3RB

TEL: 01227 773035
FAX: 01227 770035
E Mail: qstraint@qstraint.com

SAFETEX

Unit 16 / 17
Bookham Industrial Park
Church Road
Bookham
Surrey
KT23 3EU

TEL: 01372 451272
FAX: 01372 451282
E Mail: sales@safetex.com

USER GUIDE 1.0

THE SEATING SYSTEM WHEELCHAIR INTERFACE

- The Foam Cast Seating System will have been built to suit the wheelchair specified at the assessment. The method of interfacing the seat may vary and the 2 types of interface options are described in this section.

1.1. LOCATING THE FOAM CAST SEAT FRAME

CANVAS FITTING INTERFACE METHOD

If the Foam Cast Seating System has been set up to interface on the existing wheelchair canvases then the following method is used to install and remove it from the wheelchair.

- Whilst holding the Foam Cast Seat, place this into the wheelchair making sure that the front bar on the support frame locates behind the armrest upright posts (Fig.1.1a) or into the ski brackets (Fig.1.1b).
- Having located the seat behind the armrest uprights gently lower the back of the seat onto the wheelchair backrest canvas. The seat will now be able to sit into the wheelchair.
- The seat retention straps now need to be fastened around the back of the wheelchair.
- Seat Retention Straps are secured around the back of the wheelchair frame, not just the wheelchair canvas (Fig.1.1c).
- With the Foam Cast Seating now installed into the wheelchair it is now safe to place the client in position.
- **S.O.S. Seating Systems need to be interfaced to the wheelchair safely and it is important that the retention straps are always secured for client safety.**
- Removing the Foam Cast Seating from the wheelchair is the reverse of the above procedure.



Fig. 1.1a

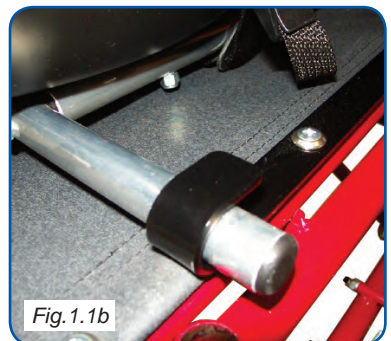

Fig. 1.1b



Fig. 1.1c

HANGER BRACKET INTERFACE METHOD

If the Foam Cast Seating System has been set up to interface into the wheelchair with Location Hanger Brackets then the following method is used to install and remove it from the wheelchair.

- Firmly holding the Foam Cast Seat lower it into the wheelchair. As you lower the seat into the wheelchair please note that under the support frame on the seating system you will see some additional brackets, these are the Location Hanger Brackets and are intended to sit onto the seat rails of the wheelchair. Gently lower the seating system into position making sure that the Hanger Brackets locate on the seat rails (Fig.1.1d).
- Having lowered the seat onto the seat rails and located the Hanger Brackets the rear of the seat needs to locate onto the back of the wheelchair. Slide the seating system back on the seat rails until the rear Location Hanger Bracket sits against the backrest of the wheelchair.
- With the seating system Hanger Brackets located on the seat rails and the backrest posts of the wheelchair it is now necessary to slide the Hanger Bracket lock tubes into position where fitted (Fig.1.1e).
- With the locking tubes in position tighten the locking screws to secure permanently.
- Having attached all the hanger brackets into position as described above all that remains to be done is to fit the rear retention strap (on the support frame of the seating system) around the back of the wheelchair and secure in position (Fig.1.1f).
- The seat is now ready to use.

- **Special Seating System Restraint Straps must always be in position and tightened firmly. This is essential during transportation of the client, to ensure client safety.**

- **Check tightness of these straps regularly. loose straps are potentially dangerous and may not secure the Foam Cast Seat properly.**
- To remove the seating system from the wheelchair simply, reverse the above procedure.

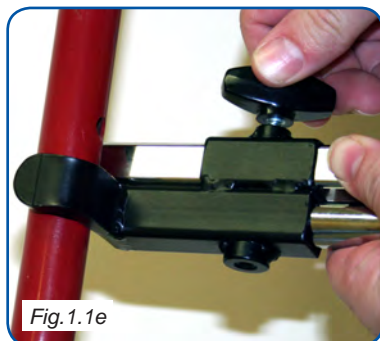
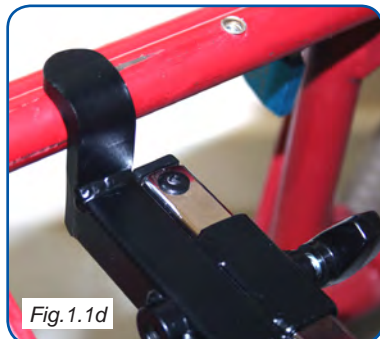

QUICK RELEASE (Quick-Loc) INTERFACE METHOD

- Whilst holding the Foam Cast Seat, place this into the wheelchair making sure that the front of the interface frame locates into stops as shown (Fig.1.1g).
- Lower the back of the seat into the wheelchair until the interface locates into the rear catches as shown and it clicks into position (Fig.1.1h).
- Secure the Seat Retention Strap around the back of the wheelchair frame, not just the wheelchair canvas (Fig.1.1j).
- With the Foam Cast Seat now installed into the wheelchair it is now safe to place the client in position.
- **S.O.S. Seating Systems need to be interfaced to the wheelchair safely and it is important that the retention straps are always secured for client safety.**
- Before removing the Foam Cast Seat, SOS recommend that the client is removed from the seating system.
- To remove the Foam Cast Seat from the wheelchair, release the retention strap, pull back the interface lever or cable (Fig.1.1k) until the catches release, raise up the rear of the interface clear of the catches, release the lever and pull the interface clear of the front stops.

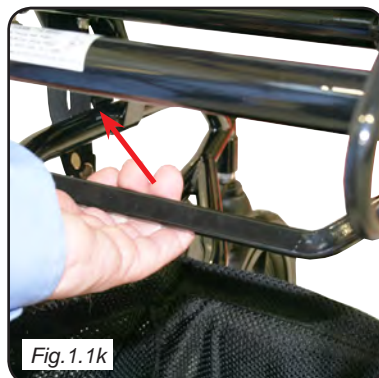
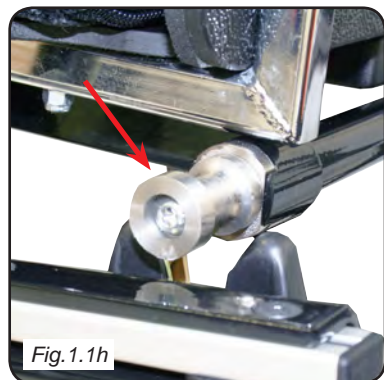
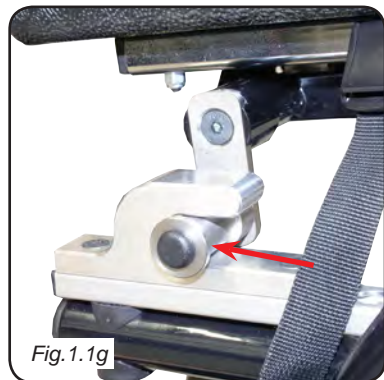

1.2. FOAM CAST SEAT COVER

- If the Foam Cast Seat is fitted with a cover, check that the cover fits neatly.
- Every time a cover is made for the Foam Cast Seat a pattern is kept. Therefore if any duplicate covers are required, these can be easily made without the need to see the client or the Foam Cast Seat.

Contact your Wheelchair Service or SOS (see back page for details) for further details .

1.3. ELECTRIC WHEELCHAIRS

- When fitting the Foam Cast Seat to an electric wheelchair, the fitting procedures are the same as in 1.1.
- However it is also necessary to make sure that any electric cables etc., are not trapped or jammed by the Foam Cast Seat during placement into an electric wheelchair.

1.4. MAINTAINING THE WHEELCHAIRS

- It is important that the wheelchair manufacturers guidelines for maintenance are carried out.
- Under inflated tyres or faulty brakes etc. can render a wheelchair dangerous if used with such faults.
- All new wheelchairs are supplied with a copy of the manufacturers user instructions.
- You should have a copy of the Wheelchair Manufacturers User Information.
- If you do not have a copy, contact your Wheelchair Service to obtain a copy.

Always maintain your wheelchair as per manufacturers instructions.

USER GUIDE 2.0

2.1. LIFTING & HANDLING THE CLIENT IN & OUT OF THE FOAM CAST SEAT

- Most users of Foam Cast Seats will need to be hoisted into the equipment. Manually lifting the client is not recommended, however with some clients it may not be possible to hoist them safely by conventional means and in instances such as this you are recommended to carry out a **'RISK ASSESSMENT'** to assess the risks involved in any such action.
- It is important that all carers are aware of the Health & Safety guidelines for **'Lifting and Handling'**.
- Before lifting the client make sure all straps are placed out of the Foam Cast Seat, this will avoid the straps becoming trapped under the client when seated.
- When using the hoist, make sure that you follow the **hoist manufacturers instructions** regarding correct use.
- On lowering the client into the Foam Cast Seat make sure that the client's hips / pelvis are located as far back as possible into the seat.
- Leaving the hoist sling in the Foam Cast Seat once the client has been placed is not recommended as this could cause discomfort and pressure areas to be generated. However, if any management issues require the sling to be left in situ, then it is recommended that the most appropriate sling be used. If you require further information regarding this, contact your local Wheelchair Service Therapist.
- **Please note, that it is very important that the client is correctly positioned to give maximum comfort and support.**

2.2. CLIENT STRAPS / HARNESES

- Secure all straps / harness supplied. Straps and harness must be tightened to work correctly.
- It is dangerous to have straps too loose or not in place on the client.
- If the Foam Cast Seat has been fitted with a 'Butterfly X Harness', it is important that it is correctly adjusted to maintain safe clearance at the top of the harness as illustrated in the diagram opposite at 'X'.

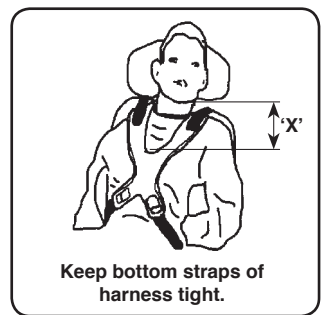

2.3. FOOTREST ADJUSTMENT

- It is recommended that feet be supported on the foot supports provided to ensure that the client is seated with optimum comfort.
- Leaving the clients feet unsupported is not recommended as this can lead to great discomfort and abnormal pressure being generated at the pelvis and other weight bearing areas.
- It is therefore essential that the footrests of the wheelchair be adjusted correctly (see Wheelchair User Manual for details).

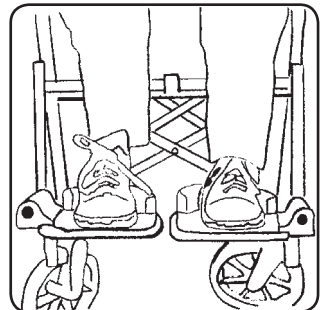

USER GUIDE 3.0

MAINTENANCE OF THE FOAM CAST SEAT

To make sure that the Foam Cast Seat remains satisfactory it is necessary to carry out simple maintenance.

3.1. CLEANING THE FOAM CAST SEAT

- During use the Foam Cast Seat will require cleaning. This can be done by simply applying a warm damp cloth with a mild detergent to the inside surface of the seat to remove any soiling and towel dry. **Note:** The cover **MUST** be removed prior to any cleaning of the seat.
- If the Foam Cast Seat remains slightly damp simply leave for a short period at room temperature to dry.
- The inner Foam Moulding on the Foam Cast Seat is made from an open cell foam and is sealed in a special water proof clear plastic protective skin which although waterproof is air permeable to assist daily management. Under no circumstances is the clear protective skin to be removed as the foam will have no protection against contamination and will need to be replaced. If the plastic skin becomes seriously damaged contact SOS immediately. To clean the foam moulding, simply wipe down with mild detergent and a damp cloth and towel dry and leave at room temperature to dry thoroughly. Under no circumstances use excessive heat to try to dry the foam as this could damage the protective skin.
- To clean the outside of the Foam Cast Seat simply wipe down with a warm damp cloth (a mild detergent may be used) and wipe dry.
- **DO NOT PUT THE MSI NEXT TO A HOT FIRE OR USE EXCESSIVE HEAT TO DRY AS EXCESSIVE HEAT COULD AFFECT THE SHAPE OF THE SEAT.**
- **DO NOT USE SCOURERS OR CAUSTIC SUBSTANCES SUCH AS BLEACH.**

3.2. REMOVABLE COVERS

- Light soiling on the cover can simply be removed by using a damp cloth. This should enable the cover to be cleaned without the need to remove it from the Foam Cast Seat as the foam is sealed in a waterproof liner.
- For cleaning of removable cover please refer to wash label on the inside of the padded cover.
- To remove the cover simply lift and remove the cover taking care to guide any straps etc. through the cover before removing.
- **DO NOT REMOVE THE FOAM FROM THE WATERPROOF LINER OR TRY TO WASH IT AS THIS FOAM WILL ABSORB WATER AND WILL BE A PROBLEM TO DRY OUT.**
- **ANY DEVIATIONS FROM THE ABOVE MAY AFFECT THE FIRE RETARDANCY OF THE COVER(S).**

3.3. HARNESSSES, PADS & STRAPS

- Make sure all straps are in good working order and that buckles work correctly.
- If any show signs of fraying or any buckles are broken or faulty contact your Wheelchair Service immediately, **DO NOT ATTEMPT TO REPAIR.**
- Harnesses may be cleaned by applying a warm damp cloth with a mild detergent, **DO NOT USE POLISH.**

3.4. VISUAL INSPECTION

- Every 3 - 4 weeks check the condition of the Foam Cast Seat and wheelchair, if you notice any faults or broken parts please notify your Wheelchair Service immediately, **DO NOT ATTEMPT TO REPAIR.**
- Look at the tubular frame of the Foam Cast Seat and make sure there are no signs of distortion, make sure it is securely attached to the moulded shell of the seat and there are no loose attachments.
- Check the moulded shell of the seat for any signs of severe wear and tear. Also the foam lining of the seat.

3.5. FIRE RETARDANCY

- Fire retardant materials have been used in the construction of this seating system.
- It is important that no accelerants are introduced to the materials (e.g. Hairspray, fabric cleaners, deodorants, polish etc..), as this may adversely affect the fire retardancy of your equipment.

USER GUIDE 4.0

OPTIONAL FEATURES

4.1. ADJUSTABLE HEADREST

- If the Foam Cast Seat has been fitted with an adjustable headrest, the headrest will have been adjusted when the Foam Cast Seat was originally supplied.
- If any adjustments need to be carried out this can be done by releasing the locking knobs and adjusted for height (Fig.4.1a) and depth (Fig.4.1b), re-tighten locking knobs when finished.
- **PLEASE NOTE THAT SOS RECOMMEND THE HEADREST IS USED AT ALL TIMES WHENEVER THE CLIENT IS BEING TRANSPORTED IN THEIR WHEELCHAIR AND SEATING SYSTEM.**



4.2. ADJUSTABLE FOOTREST

- If the Foam Cast Seat has an adjustable footrest, it is important that the feet are well supported (Fig.4.2a) and the footrest positioned correctly. The footrest will have been correctly adjusted when the equipment was handed over in clinic as opposite.
- The footrest is adjustable for height (Fig.4.2b) and reach (Fig.4.2c).
- If the Foam Cast Seat has been set up for use with the standard wheelchair footrests, then these will be adjusted correctly when the equipment is handed over in clinic. Adjustments can easily be done to the footrests if necessary (see the wheelchair manufacturers user information for more details).
- If the Foam Cast Seat has been set up to use an integral footrest (Fig.4.2a), then the wheelchair footrests are not to be used.

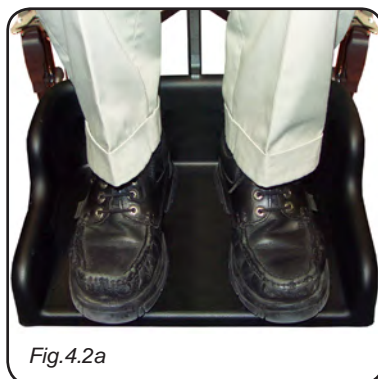



4.3. DETACHABLE POMMEL

- If the Foam Cast Seat has a detachable pommel this is secured in place by either a wing knob underneath the seat or a locking knob at the front of the pommel.

Wing Knob Underneath:

- To remove/adjust, turn the wing knob (Fig.4.3b) underneath the seat anti-clockwise to release. The pommel can then be withdrawn/adjusted (Fig.4.3a) and re-tightened when in position.
- Re-fitting is a reversal of the above procedure.



Locking Knob at Front:

- To remove/adjust, turn locking knob (Fig.4.3c) at the front of the bracket anti-clockwise to release. The pommel can then be withdrawn/adjusted (Fig.4.3a) and re-tightened when in position.
- To replace simply insert bracket stem back into the square socket, slide into desired position and lock into place, turning the lock knob clockwise until secure making sure that the barrel lock is correctly positioned as shown (Fig.4.3c).

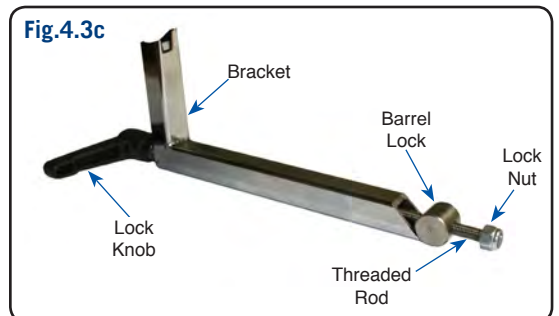

You can identify all the relevant parts supplied with your Foam Cast Seat by referring to Page 1, ***“Specification of the Seating System supplied”***.

IF YOU DETECT A FAULT OR BREAKAGE

1. IF YOU DETECT A FAULT OR BREAKAGE OF THE EQUIPMENT THEN REPORT THIS IMMEDIATELY.
2. UNDER NO CIRCUMSTANCES ARE ANY MODIFICATIONS / ALTERATIONS TO BE DONE BY ANYONE OTHER THAN SPECIALISED ORTHOTIC SERVICES LTD (see contact details enclosed).
3. TO CONTACT SPECIALISED ORTHOTIC SERVICES LTD PLEASE REFER TO THE INFORMATION INCLUDED IN THIS USER MANUAL.

REPAIRS & SERVICE

Within the warranty period.

All Seating Systems manufactured by Specialised Orthotic Services Ltd. carry a guarantee on the main parts for 12 months, excluding covers and straps which are guaranteed for 3 months, when used normally. If during this period the product becomes defective and needs repair then please contact SOS (please see the end of this users guide for details). You can also contact your local wheelchair service regarding any faults requiring attention.

Outside the warranty period.

For any goods requiring repair or attention after the guaranteed period, then assessment can be made as to the cost of the work required to effect the repair.

On acceptance of this quotation the work will proceed.

Misuse or neglect.

The repairs necessary resulting from misuse or neglect, whether within the warranty period or not will be charged for.

MEDICAL DEVICES DIRECTIVE 93 / 42 EEC

Specialised Orthotic Services Ltd. in compliance with the Medical Devices Directive have an obligation to investigate and take corrective action on defective devices. To assist us with this procedure we would appreciate your assistance in meeting this obligation by informing us as soon as possible and make the device available for inspection as soon as possible having become aware of a defect.

We are required to notify the Competent Authority of certain types of incidents within 10 to 30 days.

As part of our quality system we have established procedures to deal with such incidences and would appreciate your swift notification to us via our telephone, fax or e-mail details at the end of this users manual.

If you require further copies of this handout or require further details relating to any of its content, then please contact us (Copyright applies):



Units 127/128, Fauld Industrial Park, Tutbury, Staffordshire. DE13 9HS
Tel: 0044 (0)1283 520400 Fax: 0044 (0)1283 520401
E-mail: enquiries@specialorthotic.com
Web: www.specialisedorthoticservices.co.uk