

Impact²[®]

Electronic Pipettor



User Manual

.....



Manual 16420 RevD

© 1993, 1996, 1998, 2006 Matrix Technologies Corp. All rights reserved. No part of this publication may be reproduced, stored in a retrieval system, or transmitted, in any form or by any means, in whole or in part, without the prior written permission of Matrix Technologies Corporation.

Licensed under Rainin U.S. Patents 4,905,521 and 5,187,990 and corresponding foreign patents.

Impact, TallTips, ECOTIPS, Matrix Technologies Corp, and the Matrix logo are registered trademarks of Matrix Technologies Corporation.

Printed in the USA.

CONTENTS

Congratulations!	1
Before You Begin.....	1
A. INTRODUCTION	2
A.1 <i>Impact</i> ² Single Channel	3
A.2 <i>Impact</i> ² Multichannel	3
B. PIPETTOR OVERVIEW.....	4
B.1 Components.....	4
B.2 General Description	5
B.3 Keypad	6
B.3.1 Operation Keys	6
B.3.2 Programming Keys.....	7
B.3.3 Special Function Key	8
B.4 Display	10
B.5 Pipettor Specifications.....	11
B.6 Hazards and Precautions.....	12
C. PROGRAMMING AND OPERATION	13
C.1 Programming the <i>Impact</i> ²	13
C.1.1 Open Programming Mode or “Scratch Pad” (P-0)	13
C.1.2 Entering a Program in Open Programming Mode.....	13
C.1.3 Storing a Program.....	16
C.1.4 Program Recall	17
C.1.5 Adjusting Pipetting Speed	17
C.1.6 Reviewing the Program.....	17
C.2 Programming Examples.....	18
C.2.1 Sample Transfers.....	18
C.2.2 Incremental Pipetting	19
C.2.3 Serial Dilutions	19
C.2.4 Simple Dilutions	20
C.2.5 Supernatant Collection.....	20
C.3 Operating Procedures.....	21

D. CALIBRATION	23
D.1 Volume Measurement	23
D.2 Pipettor Calibration	24
D.2.1 Factory Calibration Step	24
D.2.2 “EASY” Cal Mode.....	24
D.2.3 “CALC” Mode	25
D.2.4 CALVIEW	27
D.2.5 CALRESET	27
D.3 Recommendations for Accurate Pipetting.....	27
E. TROUBLESHOOTING.....	29
F. MAINTENANCE	31
F.1 Single Channel <i>Impact</i> ² Maintenance	32
F.1.1 Single Channel <i>Impact</i> ² Disassembly	32
F.1.2 Single Channel Cleaning and Autoclaving.....	34
F.1.3 Pipettor Reassembly.....	34
F.2 Multichannel <i>Impact</i> ² Maintenance	35
F.2.1 Multichannel <i>Impact</i> ² Disassembly.....	35
F.2.2 Multichannel Cleaning and Autoclaving	38
F.2.3 Multichannel Maintenance and Reassembly	38
F.3 Installing/Replacing Batteries	44
F.3.1 Installing/Replacing NiMH Batteries	44
F.3.2 Installing/Replacing Lithium-Ion Battery (16 Ch)	48
F.4 Charging/Recharging Batteries.....	50
F.4.1 Charging/Recharging NiMH Batteries.....	50
F.4.2 Charging/Recharging Lithium-Ion Battery (16 Ch).....	51
G. TECHNICAL SERVICE	53
G.1 Instrument Warranty	53
G.2 On Site Service - Calibration & Maintenance	54
G.3 Factory Service - Calibration, Maintenance, & Repair.....	55
G.4 Recommended Equipment Decontamination Methods	56
G.5 Equipment Decontamination Form	57

Congratulations!

You have purchased the state-of-the-art in precision pipetting. The ***Impact***^{2®} is the first cordless electronic pipettor that “understands” the myriad of liquid handling protocols typically performed in today’s laboratory.

Ergonomically designed and balanced to reduce fatigue, the ***Impact***² functions so intuitively, you may need no more than a quick survey of this manual to use it.

The ***Impact***² executes your liquid pipetting tasks quickly, accurately, and with less risk of developing repetitive strain injuries (RSI) typically associated with manual pipettor use. Laboratory results will become more standardized, while less time is expended on tedious bench procedures.

Before You Begin

Before using the ***Impact***², verify the contents of the package. The package should contain the following items:

- 1 ***Impact***² Pipettor
- 1 Operator’s Manual
- 2 Rechargeable NiMH Batteries or 1 Lithium-Ion Battery (*16 Channels*)
- 1 AC Power Transformer
- 1 Warranty Card
- 1 Accuracy/Precision Data Sheet

If items are missing, contact a Matrix representative or contact customer service at **(800) 345-0206**.

Note: *Batteries must be installed and recharged before using the ***Impact***². Refer to the following sections in this manual:*

Section F.3, Installing/Replacing Batteries

Section F.4, Charging/Recharging Batteries

A. INTRODUCTION

It's time to Impact your lab!

The **Impact²** is the second generation of the **Impact** pipettor family, providing the convenience of a manual pipettor, with the programming capabilities of an electronic pipettor. The **Impact²** pipettor features include:

- Expanded memory for storing up to five pipetting programs.
- Each program can hold a maximum of 40 steps.
- “Scratch Pad” programming mode which allows for fast and simple program changes that are not stored into memory.
- Enhanced speed control offers slower aspirating and dispensing of viscous liquids. *Excellent for gel loading!*
- “EASY” CAL which simplifies in-lab calibration verification using distilled water.

The **Impact²** is lightweight and cordless, utilizing rechargeable batteries, which can be used while recharging (*with the exception of single channel pipettors*). The pipettor also has an automatic shut-off feature to extend battery life.

The **Impact²** uses integrated circuit technology to store programming information. It will hold up to 40 steps in a program, with up to 5 programs saved in memory, and 1 scratch pad (See section C.1.1 *Open Programming Mode* or “Scratch Pad”). The program information is retained in memory, even if the batteries are fully discharged or removed.

The **Impact²** uses a “paced dispense” feature that performs repeat pipetting steps while the trigger is depressed.

A.1 **Impact²** Single Channel

The **Impact²** single channel pipettors are available in a number of model configurations (see *Figures A-1*) from 12.5µl to 1250µl, ranging in volume from 0.5µl to 1250µl. Each pipettor is color-coded with a color ring for easy volume identification (see section B.5, *Pipettor Specifications*). Two models, 250µl and 1250µl, are also available as a “Shorty”, which are shorter in overall length compared to the standard pipettors.

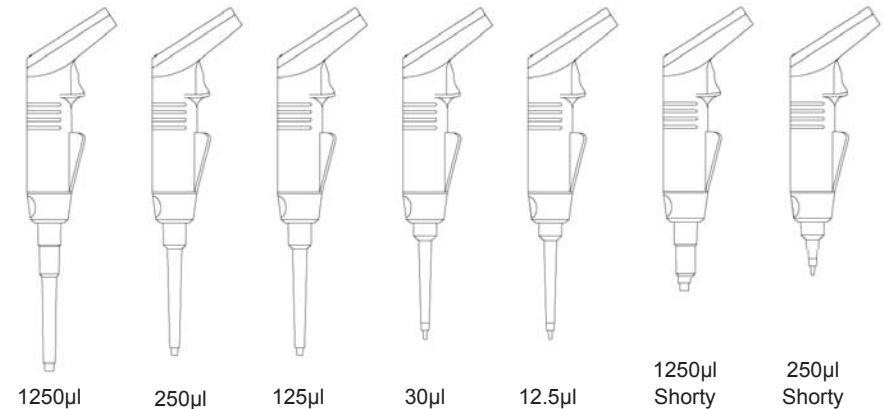

Figure A.1: Single Channel Models

A.2 **Impact²** Multichannel

The **Impact²** multichannel pipettors are available in a number of configurations from 8 to 16 channels. An expandable **Impact²** EXP is also available in 6 channel and custom configurations. Models range in volume from 0.5µl to 1250µl. Each pipettor is color-coded with a color ring for easy volume identification (see section B.5, *Pipettor Specifications*). Please see our **Equalizer[®]** for a pipettor that has equal tip spacing between 4.5mm and 14.15mm (*depending on model*).

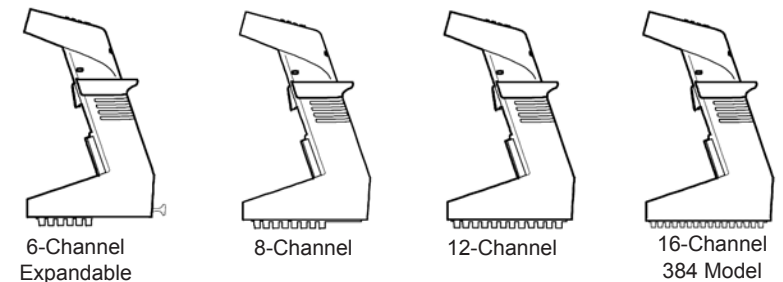

Figure A.2: Multichannel Models

B. PIPETTOR OVERVIEW

B.1 Components

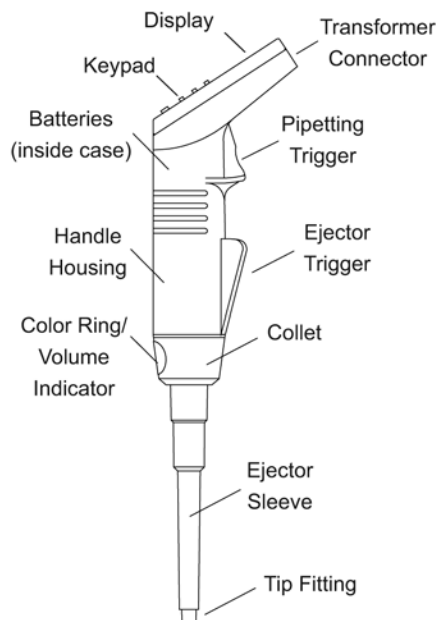

Figure B.1a:
Single Channel Components

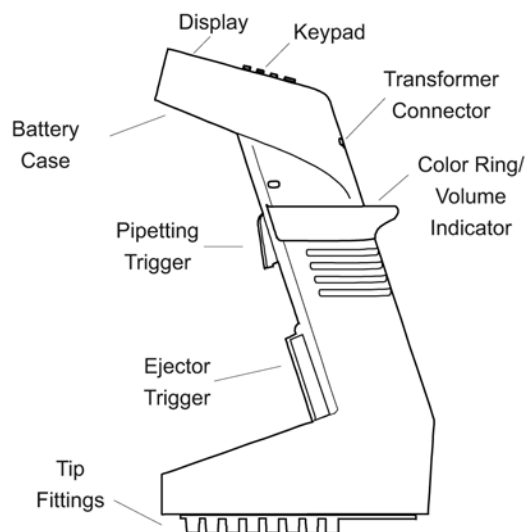

Figure B.1b: Multichannel Components

B.2 General Description

Keypad. The keypad contains the operation keys that are used in programming the pipetting sequence and volumes. (See Section B.3, Keypad).

Display. The display is an LCD screen that shows the pipetting operation (*fill, dispense, mix, or purge*) and fluid volume for each step in the pipetting program. (See Section B.4, Display).

Battery Case. The battery case contains the rechargeable batteries. Nickel Metal Hydride batteries fully charge in 14-16 hours, while Lithium-Ion batteries fully charge in 2 hours. The *Impact*² can perform a full days workload with no need to recharge. Battery life is extended with automatic shut-off after 10 minutes of inactivity. (See Section F.3, *Installing/Replacing Batteries*).

Pipetting Trigger. The pipetting trigger initiates a program. A single pipetting step is executed by a quick press and release of the trigger. Repeat pipetting is executed by pressing and holding the trigger.

Note: *At the end of any dispense, the pipet tips should be removed from the fluid before releasing the trigger, to prevent aspiration of fluid.*

Ejector Trigger. The ejector trigger is pressed to eject the pipet tips from the pipettor.

Tip Fittings. The tip fittings form an airtight seal with the pipet tips to ensure accuracy while pipetting.

Note: *Impact*² pipettors are equipped with chemically-resistant (PEEK) tip fittings (and ejector sleeves on single channel models) allowing pipetting of acidic solutions without damage to the tip fittings.

Color-coded Ring. The ring around the pipettor handle is color-coded to identify the pipetting volume of the handle (See Section B.5, *Pipettor Specifications*).

Transformer Connector. The transformer connector receives the plug from the power transformer for recharging the batteries. The pipettor can be used while recharging (*with the exception of single channel pipettors*).

B.3 Keypad

The keypad contains the operation keys, programming keys, and the special function key.

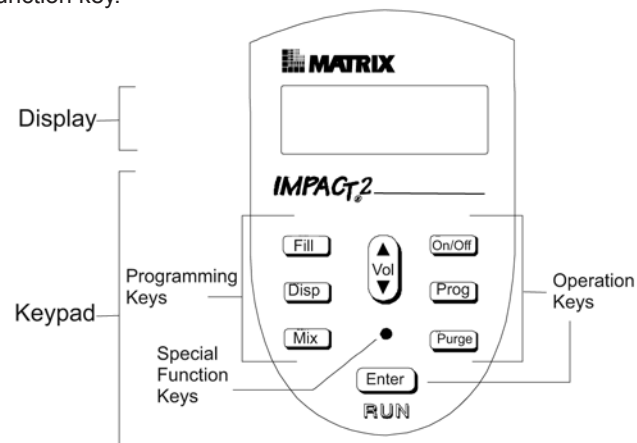

Figure B.3: Impact² Keypad

B.3.1 Operation Keys

[On/Off] The On/Off key turns the pipettor on or off. When the pipettor is turned on, it emits a beep tone, flashes “ZERO” on the display, then automatically resets the pistons to zero position. After zeroing, the display shows the first step of the program in the RUN mode.

Note: If the pipettor is being programmed for the first time, the first step will be the fill operation, with the default fill volume. (See Section C.1, Programming the Impact², for the default settings).

[Prog] The Program key on the Impact² enables you to store up to five separate programs in memory for future recall. Each program can hold up to 40 steps. Programs are stored in reserved program location numbers 1 – 5. Program “0” is used as a “scratch pad” where temporary programs can be written, run, and overwritten easily. Program “0” is considered to be an “open” program. (See Section C.1, Programming the Impact²).

[Purge] The Purge key enters a purge prompt anytime during a pipetting operation to abort the program. By pressing the Purge key, then pressing the trigger, you can dispense any remaining liquid from the pipet tips and return to the beginning of the program.

The Purge key is also used to enter the purge step into a program.

Note: If there is insufficient liquid for a final dispense step, the pipettor emits a beep tone and automatically displays the purge prompt.

RUN The RUN mode performs the operation that is displayed, such as fill, dispense, mix, or purge. When “Run” appears in the display, you can activate the RUN mode by pressing the trigger. At the end of a pipetting sequence, the pipettor emits a triple beep tone and returns to the beginning of the program. The pipettor remains in RUN mode until you program a new pipetting sequence.

B.3.2 Programming Keys

[Fill] The Fill, Dispense, and Mix keys program the pipetting operations. By pressing one of these keys, you can enter the programming mode of the Impact². The “Run” prompt disappears from the display and the appropriate operation appears with a flashing “Vol” prompt. Fill, dispense, or mix volumes can be programmed by pressing the Volume key. Also, the number of mix cycles can be programmed by pressing the Mix key twice.

[Mix] **Automatic blowout:** At the end of a final dispense step, the pipettor automatically expels any remaining liquid from the pipet tips with a short burst of air (**blowout**). The pistons then reverse direction and return to zero position.

Note: If you press and hold in the trigger during the final dispense step, the pipettor performs the automatic blowout and holds its position until you release the trigger. This delay allows you sufficient time to remove the tips from the liquid to prevent aspiration of liquid, as the pistons return to zero position.



The Volume key controls the quantity of liquid to be aspirated or dispensed. The volume can be entered when the “Vol” prompt appears.

Pipetting volume can be incremented quickly by continuously depressing the Volume key. The longer you hold the key, the greater the incremental speed.

The Volume key can also be used to change pipetting speeds within a stored program or during the execution of a program. (See Section C.1.5, *Adjusting Pipetting Speed*).

[Enter] The Enter key stores the program in memory. After each step is programmed, the Enter key is pressed once to accept the step. After the final step is programmed, the Enter key is pressed twice to denote the end of the program. The pipettor verifies the end of the program with a triple beep tone.

B.3.3 Special Function Key

The Special Function key is the small hole below the Volume key. It can be activated with a pipet tip. By repeatedly pressing the Special Function key, you can display four functions: Pipetting Speed (SPd), Beep Tone (TONE), Paced Dispense Speed (PACE), and Calibration (CAL). To exit the Special Function key at any time, press the Enter key.

TONE The beep tone signals the completion of one or more steps, or signals a warning:



- **Single beep tone:** end of pipetting step.

- **Double beep tone:** operation or programming key is not active in current mode; insufficient dispense volume, purge required; or illegal programming step attempted (see Section E, *Troubleshooting*).
- **Triple beep tone:** end of pipetting sequence; end of programming sequence.

There are three options to choose from in setting the beep tone. ON1 will have all tones sound at the appropriate times listed above. ON2 will use only double and triple beep tones. OFF will turn off all tones except for the tone to signify an illegal programming step. Press the Special Function key twice to display “TONE” and its current setting. To change the setting, press the Volume key. If the beep tone is set for ON1 or ON2, the beep tone symbol “•)))” appears at the bottom of the display.

Note: For paced dispensing, the beep tone should be set ON1, to prepare you for each dispense step.

PACE The pace controls the speed of repeat pipetting (*paced dispensing*), FAST, SLOW or OFF. Press the Special Function key three times to display “PACE” and its current setting. To change the setting, press the Volume key.

Paced Dispense. When using the paced dispense feature, the pipettor dispenses the programmed volume at the specified pace (*fast or slow*). Immediately after each dispense step, the pipettor emits a single beep tone (*if beep tone is on*) to prepare you for the next dispense step (see Section C.5, *Operating Procedures*).

CAL The calibration of the pipettor is factory set for distilled water at room temperature. If you are pipetting fluids with significantly different specific gravities or temperatures, use this setting to recalibrate the pipettor. (See Section D, *Calibration*).

SPd Once in the special function mode, adjust the pipetting speed by pressing the Volume key. Five speed settings are available:

Speed Setting	Display
Slow	S
Medium Slow	S ■
Medium	S ■ ■
Medium Fast	S ■ ■ ■
Fast	S ■ ■ ■ F

The current speed setting appears at the bottom of the display. These settings can be selected and changed at any time before a program step is executed.

B.4 Display

The pipettor display is a dynamic LCD screen. It displays the current operation, volume prompt (if entering a program), pipetting volume, low battery indicator (appears if battery charge is low), beep tone symbol (if the beep tone is on), pipetting speed, and program number.

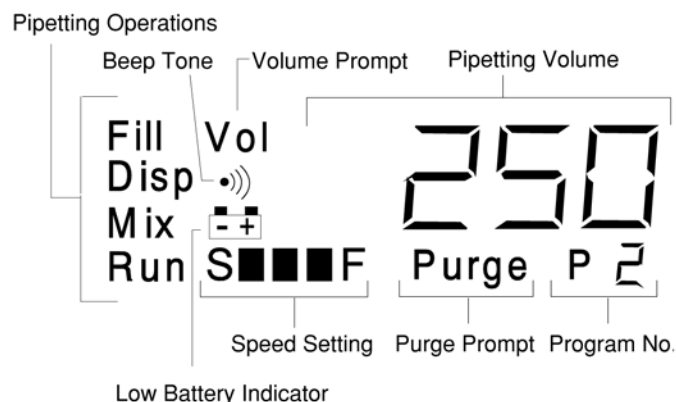

Figure B.4: Impact² Display

B.5 Pipettor Specifications

Item No.	Volume	Channel	Volume Range	Color Ring	Accuracy* (±)	Precision** (±)
1029	12.50µl	Single Ch	0.50-12.50µl	Red	1.0%/0.05µl	0.4%/0.05µl
1020	30.0µl	Single Ch	1.0-30.0µl	Purple	1.0%/0.15µl	0.3%/0.05µl
1021	125.0µl	Single Ch	2.0-125.0µl	Yellow	0.6%/0.3µl	0.2%/0.1µl
1022	250µl	Single Ch	5-250µl	Blue	0.6%/0.5µl	0.15%/0.15µl
1024	1250µl	Single Ch	15-1250µl	Green	0.5%/3.0µl	0.13%/0.6µl
1122	250µl	Shorty	5-250µl	Blue	0.6%/0.5µl	0.15%/0.15µl
1124	1250µl	Shorty	15-1250µl	Green	0.5%/3.0µl	0.13%/0.6µl
2621	125.0µl	6-Ch EXP	2.0-125.0µl	Yellow	2.0%/1.0µl	1.0%/0.6µl
2622	250µl	6-Ch EXP	5.0-250.0µl	Blue	2.0%/1.5µl	0.7%/1.0µl
2624	1250µl	6-Ch EXP	15-1250µl	Green	1.5%/6.0µl	0.6%/3.0µl
2009	12.50µl	8-Ch	0.50-12.50µl	Red	2.5%/0.15µl	2.0%/0.15µl
2001	125.0µl	8-Ch	2.0-125.0µl	Yellow	2.0%/1.0µl	1.0%/0.6µl
2002	250.0µl	8-Ch	5.0-250.0µl	Blue	2.0%/1.5µl	0.7%/1.0µl
2004	1250µl	8-Ch	15-1250µl	Green	1.5%/6.0µl	0.6%/3.0µl
2019	12.50µl	12-Ch	0.50-12.50µl	Red	2.5%/0.15µl	2.0%/0.15µl
2011	125.0µl	12-Ch	2.0-125.0µl	Yellow	2.0%/1.0µl	1.2%/0.8µl
2012	250.0µl	12-Ch	5.0-250.0µl	Blue	2.0%/1.5µl	0.8%/1.2µl
2014	850µl	12-Ch	15-850µl	Orange	1.5%/4.0µl	0.6%/2.5µl
2069	12.50µl	16-Ch	0.50-12.50µl	Red	2.5%/0.15µl	2.0%/0.15µl
2060	30µl	16-Ch	1.0-30.0µl	Purple	2.0%/0.30µl	1.7%/0.30µl
2061	125µl	16-Ch	2.0-125.0µl	Yellow	2.0%/1.0µl	1.2%/0.8µl

Table B.5 Pipettor Specifications

Note: For Accuracy and Precision, values shown are expressed as a percent (%) deviation or microliter (µl) value. When applied to desired volume, the greater of the two values will always apply.

* Both values represent the deviation from the mean.

** Percentage values are expressed as the coefficient of variation. Microliter values are expressed as the standard deviation.

B.6 Hazards and Precautions

There are no known hazards associated with the *Impact*² when it is operated in accordance with the instructions in this manual. However, you should be aware of situations that can result in serious injury.

Note: *Do not perform troubleshooting procedures on the internal components unless instructed by Matrix Technical Service personnel.*



WARNING! Ensure that the power transformer is connected to a power receptacle that provides voltage and current specified by Matrix. Use of an incompatible power receptacle can cause shock and fire hazard.

CAUTION! Use only the power transformer supplied by Matrix Technologies. Use of an incompatible power transformer can damage the pipettor.

CAUTION! Always turn off the power and unplug the power transformer before cleaning the exterior. Fluid seepage can damage internal components.

CAUTION! Do not immerse the unit in liquid. Fluid seepage can damage internal components.

CAUTION! Do not autoclave the entire unit. Extreme heat can damage the display and other electronic components.

Note: *For autoclaving specific portions of the pipettor, refer to the Autoclaving Procedures, or call Matrix Technical Service for instructions.*

CAUTION! Do not clean the keypad with bleach solution or other solvents. Caustic cleaning solutions can damage the keypad.

CAUTION! Avoid excessive charging of the batteries when the pipettor is not in use. Excessive charge to the batteries will shorten the battery life and may damage the batteries.

C. PROGRAMMING AND OPERATION

C.1 Programming the *Impact*²

Programming the *Impact*² is fast and easy. Pipetting steps and volume are entered in the sequence that they will be performed, then the program is saved to memory. This program will stay in memory (even if the pipettor is turned off, or the battery runs low) until you change it. Five programs and one scratch pad (Program 0), each capable of holding 40 steps, can be entered and stored in the *Impact*².

C.1.1 Open Programming Mode or “Scratch Pad” (Program 0)

The *Impact*² provides ample program storage for five, 40 step programs. In addition, it offers open programming mode, also known as the “scratch pad.” This mode is identified by “P-0,” which appears in the program section of the display (*refer to the *Impact*² display on page 10*). This feature enables quick changes to pipetting protocols without affecting previously stored programs.

To use the “scratch pad” mode: From the start of any program, simply begin entering a new protocol (*selecting a pipetting operation as described below*). This new protocol can now be used, and will remain active until a stored program is retrieved. “P-0” appears in the program ID section of the display to indicate that the (O)pen programming mode, or “scratch pad” mode, is active.

C.1.2 Entering a Program in Open Programming Mode

To enter a pipetting program:

1. **Turn on pipettor.** Press the green [On/Off] key to turn on the pipettor. The pipettor will beep once and flash “ZERO” on the display while resetting the pistons to zero position. The first step of the current program is displayed.

Note: *If the pipettor is being programmed for the first time, the first step is the fill operation, with the default fill volume displayed (see the following table).*

Volume	Fill Volume	Dispense Volume	Mix Volume
12.50	10.00	10.00	5.00
30.0	25.0	25.0	10.00
125.0	100.0	100.0	50.0
250.0	250.0	50.0	50.0
850	850	100	100
1250	1250	100	100

Table C.1.2: Default Programming Volumes (in μl)

2. Select pipetting operation. Enter the programming mode by pressing the [Fill] or [Mix] key.

For example, to begin programming with a filling operation, press the [Fill] key. The display shows "Fill" with a flashing "Vol" prompt:

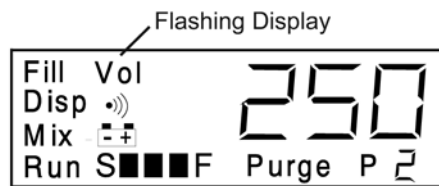

Figure C.1.2a: Flashing Volume Display

Note: The displayed volume defaults to the last volume programmed for the selected operation, or to the default volume for the pipettor, if it is being programmed for the first time.

Fill. The [Fill] key programs the pipettor to aspirate a volume of liquid. A single fill step can be programmed for fluid transfers, or a combination of fill steps can be programmed for dilutions or supernatant collection.

Dispense. The [Disp] key programs the pipettor to dispense a volume of liquid. The dispense volume can be the entire fill volume, or a smaller increment for repeat pipetting. The dispense volume needs to be programmed only once for repeat pipetting. The pipettor will dispense the volume each time the trigger is pressed (or repeatedly during a paced dispense) until the fill volume is reached, or until insufficient volume remains.

Mix. The [Mix] key programs the pipettor to perform a combination of fills and dispenses. You can program a mix volume or mix cycle (single fill and dispense). You can press [Mix] once to program a mix volume, or twice to program a mix cycle. Mix cycles from 2 to 9 are available on the *Impact*². The default setting is three mix cycles.

Some programming considerations for the mix operation:

- If the program begins a mix cycle from zero position, it will complete the cycle with an automatic blowout, then display "ZERO." Press the trigger to return the pistons to zero position.
- If the program begins a mix cycle above zero position (volume is greater than zero), the fluid is dispensed, and the mix cycle begins. The mix cycle will end at the same volume it started with. Also, the mix operation will remain in the display so it can be repeated (useful for serial dilutions), unless followed by another program step. To end the mix operation, press the [Purge] key, then press the trigger.

Purge. The [Purge] key programs the pipettor to purge the fluid. This step can be entered as a program step, or it can be pressed any time while pipetting to terminate the program and dispense the remaining liquid.

Note: If the program ends at a volume greater than zero, and the last step is not a mix cycle, the "Purge" prompt automatically appears. Also, the pipettor emits a double beep tone to warn you that some fluid remains. Press the trigger to dispense the remaining fluid and return to the beginning of the program.

Examples of pipetting programs with different mix steps are shown in Section C.2, *Programming Examples*.

3. Enter volume. Enter the desired volume for [Fill], [Disp], or [Mix] by pressing the up ▲ or down ▼ section of the [Vol] key. The longer you hold the key, the greater the incremental speed.

Note: The [Purge] key does not use a volume; therefore, if a purge step has been entered, continue to the next step.

- 4. Confirm programming step.** Press [Enter] to confirm the programming step. The display flashes all of the operation keys to prompt the next programming step:

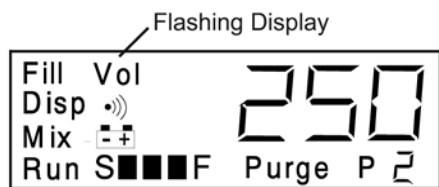

Figure C.1.2b: Flashing Display

- 5. Select next pipetting operation.** Repeat steps 2 to 4 until all programming steps have been entered.
- 6. Save program and exit.** When the display flashes all operation keys, press [Enter] to save the program and exit the programming mode. The pipettor emits a triple beep tone to signal the end of the programming sequence. The first step in the program is displayed. “Run” is displayed in the lower left corner to indicate that the new program is ready to be run. Go to Section C.1.6 for Reviewing the Program, or Section C.3 for Operating Procedures.

C.1.3 Storing a Program

To create and store programs in the *Impact*²:

1. Select the program number by pressing the [Prog] key, then press the [Vol] key until the desired program number (P1-P5) is displayed.
2. Press and hold the [Prog] key, while simultaneously pressing the Special Function key to enter the programming mode. The prompt “Prog” will appear on the display.
3. Begin entering your new program (*refer to Section C.1.2, Entering a Program in Open Programming Mode, for instructions*).

NOTE: When programming mode is active, the Speed setting and Beep Tone symbols will blink.

Upon pressing the [Enter] key to save and exit the program, the new program will be stored under the selected program number.

The program number will be displayed for two seconds. (*The first step of the newly written program is displayed*). This program is ready to be run.

C.1.4 Program Recall

To recall a stored program:

1. Press the [Prog] key, then the [Vol] key to select the desired program number.
2. Press the [Enter] key to activate the displayed program.

C.1.5 Adjusting Pipetting Speed

The *Impact*² offers unique speed control programming for Fill, Dispense, Mix, or Purge. Speeds within any of the five stored programs can be independently set and stored as an integral part of the pipetting protocol. Pipetting speed is easily changed at the start of each pipetting function.

To change pipetting speed during the execution of a program:

Press the [Vol] key to select the speed for each pipetting step (*Fill, Dispense, or Mix only*).

Note: Purge must be changed in the program.

This newly set speed will remain active with each function even if the pipettor is turned off. Speed settings within any of the five stored programs will also remain in memory with the program functions until changed by the operator.

C.1.6 Reviewing the Program

After programming the pipettor, review the programming steps:

1. **Set pipettor for RUN mode.** Ensure the pipettor is in the RUN mode (“RUN” appears in the lower left corner of the display). If the display is flashing all pipetting operations, it is still in the programming mode; press [Enter] to save the program and exit.
2. **Begin program.** Run the program without using pipet tips or aspirating fluid. Press the trigger for each step in the program.

3. Observe display. At each step of the program, observe the display. If necessary, re-enter the programming sequence.

Some helpful hints for reviewing your program:

- If the program is complex and contains several steps, write the steps on paper before entering the program. Check off each step as you review the program.
- If the program is intended for paced dispensing, review the program again, with the trigger depressed until the last step. Check the dispense pace to ensure the dispense steps are a comfortable speed.

C.2 Programming Examples

Examples of different pipetting sequences are described below, and are ideal for use as training exercises. Press the keys shown in brackets [], then press the [Vol] key until the volume in parentheses () is displayed. At the end of the program, a triple beep tone •)) is sounded. (see section D.3 Recommendations for Accurate Pipetting for suggestions for better precision and accuracy).

C.2.1 Sample Transfers

Example: Fill and dispense 100µl.

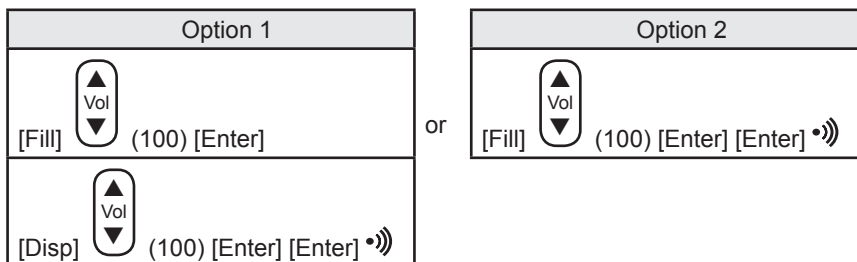

The second option is a one-step program. Because the program ends at a volume greater than zero, and the last step is not a mix, a “Purge” prompt automatically appears at the end of the fill to dispense the liquid and return to the beginning of the program.

C.2.2 Incremental Pipetting

Example: Fill and dispense 250µl.

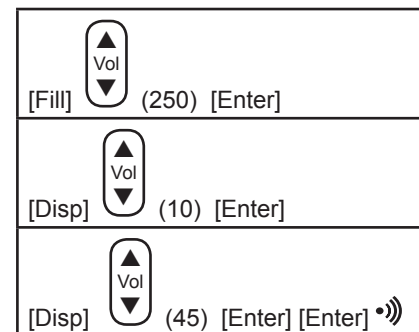

Note: The 10µl Primer Dispense reduces the percentage of error in incremental dispensing (see section D.3 Recommendations for Accurate Pipetting)

In this program, only one dispense step needs to be programmed. If any program ends in a dispense step, the pipettor repeats the dispense step until the volume is zero, or is less than the programmed dispense volume. If the remaining volume is less than the programmed dispense volume, the pipettor displays a “Purge” prompt to discard the remainder. This discarded volume contains the cumulative error of previous pipettings (see section D.3 Recommendations for Accurate Pipetting for further explanation).

C.2.3 Serial Dilutions



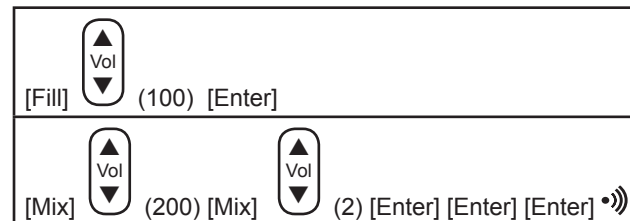

Example: Transfer 100µl to the first column of a plate previously filled with reagent. Mix 200µl for 2 cycles. Transfer 100µl to the second column and repeat the mix step. Follow this procedure for the rest of the plate.



That’s the entire program! The mix step always returns to the volume at which it started (100µl); therefore, the pipettor continues the mix step indefinitely, until you press the [Purge] key to end the program. In this example, the mix cycle is programmed for 2 cycles (default is 3 cycles).

C.2.4 Simple Dilutions



Example: Prepare 1:10 dilution with a 10µl sample volume.

[Fill]  (100) [Enter]
[Fill]  (20) [Enter]
[Fill]  (10) [Enter]
[Purge] [Enter] [Enter] 

The first fill volume is for the diluent (100µl), followed by an air gap (20µl), and finally by the sample volume (10µl). The purge step will dispense the total volume.

C.2.5 Supernatant Collection

Example: Aspirate 100µl from 8 rows of a microtiter plate and discard the total volume.

[Fill]  (100) [Enter]
[Fill] [Enter]
[Fill] [Enter]
[Fill] [Enter]
[Fill] [Enter]
[Fill] [Enter]
[Fill] [Enter]
[Fill] [Enter]
[Purge] [Enter] [Enter] 

This program is performed with the 850µl handle. All 100µl fill volumes are collected in the same tips. When completed, the total volume is discarded with the purge step.





C.3 Operating Procedures

After programming the pipettor, the display should show the first program step, with the “Run” prompt showing in the lower left corner:



Figure C.3:
Run Prompt

The following steps describe a basic program for pipetting reagent into a microtiter plate. The pipettor is programmed as follows:

[Fill]  (250) [Enter]
[Disp]  (10) [Enter]
[Disp]  (30) [Enter] [Enter] 

Note: The 10µl Primer Dispense reduces the percentage of error in incremental dispensing (see section D.3 Recommendations for Accurate Pipetting)

- 1. Attach pipet tips.** When ready to begin pipetting, attach the pipet tips to the pipettor.

Note: When applying tips, avoid ‘banging’ or applying excessive force to the tip(s), as this stretches the tip seal and will affect volume. Use Matrix tips which have been specifically designed to match the tip fittings on Matrix pipettors.
- 2. Aspirate liquid.** Immerse the pipet tips into the liquid to be aspirated, then press the trigger to aspirate 250µl.
- 3. Dispense primer volume.** Discard the 10µl primer volume.
- 4. Dispense liquid.** Position the pipet tips over the first column of wells in the microtiter plate, and press the trigger to dispense 30µl. At the completion of the dispense step, the pipettor emits a single beep tone (if the beep tone is set to ON1).

5. Repeat dispense. Repeat the previous step for the rest of the columns in the microtiter plate. At the completion of the eighth dispense, the pipettor emits a double beep tone (*if the beep tone is on, otherwise it emits a single beep tone*) and displays the “Purge” prompt. There is insufficient volume for another 30µl dispense, and the pipettor signals for a purge step.

-or-

Paced dispense. Steps 4 and 5 can also be performed as a paced dispense. Instead of pressing the trigger for each dispense step, press and hold the trigger to automatically dispense each volume. Immediately after each dispense step, the pipettor emits a single beep tone (*if the beep tone is on*), prompting you to prepare for the next dispense step. To stop a paced dispense, release the trigger before the end of the last dispense step.

Note: *For paced dispensing of small volumes, set the pace to SLOW. Ensure that you have fully released the trigger before the end of the last dispense step to prevent an additional, unwanted dispense step.*

6. Discard remaining liquid. Position the pipet tips over a waste container and press the trigger to purge the remaining liquid. The pipettor emits a triple beep tone to signal the end of the program, then returns to the first step of the program.

7. Eject tips. Press the ejector trigger to eject the used pipet tips.

D. CALIBRATION

The *Impact*² is factory-calibrated for distilled water at 20°C. For easy calibration using distilled water, the *Impact*² pipettor features an “EASY” CAL mode (see Section D.2.2, “EASY” CAL mode). When pipetting liquids of significantly different specific gravities or temperatures, however, the Calibration (CALC) feature may be used to achieve greater accuracy (see Section D.2.3, “CALC” mode).

To prepare for calibration, ensure the pipettor and tips are equilibrated. When calibrating a multichannel pipettor, select only one channel to pipet with. Using an analytical balance, first obtain the actual value of the programmed volume at factory calibration. The programmed volume (V_p) used is typically the full volume of the pipettor (for example, 200µl for the 250µl 8-channel pipettor), but is not limited to this volume.

D.1 Volume Measurement

To measure the actual value of the programmed volume:

1. Fill the programmed volume (V_p), then dispense the entire volume into a container on the analytical balance.
2. Read the weight on the analytical balance. Repeat this procedure ten times.

Note: *Use a clean and dry pipet tip with each pipetting cycle. When filling the liquid, immerse the pipet tip approximately 1/4 inch (approx. 0.6 cm) below the liquid surface. When dispensing the liquid, touch the side of the container to ensure a complete dispense.*

3. Determine the average weight of the programmed volume and convert it to volume. To convert to volume, correct the weight for specific gravity and temperature.

If weighing water, use one of the correction factors below:

Temperature	Correction Factor
20°C - 22.5°C	1.003
23°C - 25°C	1.004

The resulting volume is the corrected actual volume. If the pipettor is correctly calibrated, the programmed volume should equal the actual volume (*within the specifications of the pipettor*).

D.2 Pipettor Calibration

Impact² users can calibrate their pipettors with “EASY” CAL mode for distilled water or with “CALC” mode to calibrate other liquids and for temperatures other than room temperature.

D.2.1 Factory Calibration Step

The factory calibration step is needed when calibrating your **Impact²**. This is located on the calibration certificate called “Accuracy and Precision Verification,” enclosed in the documentation for this pipettor. (See *item CAL STEPS in the upper right hand box*). View the pipettor’s current calibration step by using the CALVIEW mode listed in section D.2.4.

Note: When resetting the calibration step to a default value, as listed in section D.2.5 CALRESET, the step is set to an average value for all pipettors of its class. This value may differ from the factory-optimized calibration step documented on the “Accuracy and Precision Verification” certificate. Please use the step listed there for best results. If you cannot locate your documentation that lists the factory calibration step, contact Matrix Tech Support at 888-363-6631, and have your pipettor’s serial number ready.

D.2.2 “EASY” Cal Mode

Impact² users can quickly calibrate their pipettor by using the unique “EASY” CAL feature. “EASY” CAL has been developed for fast, easy, in-lab verification and/or calibration using **distilled water at room temperature** (20-22.5°C).

Volume	Calibration Point (µl)	Factory Calibration Steps
12.50µl	10.00µl	Located on the calibration certificate “Accuracy and Precision Verification” sheet included in the pipettor documentation. See item CAL STEPS in upper right hand box.
30µl	25.0µl	
125.0µl	100µl	
250.0µl	200µl	
850µl	700µl	
1250µl	1000µl	

Table D.2.2: Calibration Specifications

1. Weigh out ten aliquots of distilled water on an analytical balance, using one pipetting channel. The programmed dispense volume must correspond to the calibration point for that pipettor (*for example, 200µl for a 250µl pipettor*). Refer to Table D.2.2, Calibration Specifications, for proper calibration points.

Note: Ensure that the distilled water used is at room temperature (20-22.5°C). An internal correction factor of 1.003 is used by the pipettor to convert weight (gm) to volume (ml).

2. Calculate an average for the ten readings of distilled water obtained from the balance. If the resulting average weight is within your accuracy specifications, no further calibration is required. If the average weight does not meet expected performance, enter the “EASY” CAL mode to quickly re-calibrate the **Impact²**.
3. Enter the “EASY” CAL mode by pressing the Special Function key (*using a pipet tip*) until “EASY” flashes, then press the [Enter] key to display the calibration point.
4. Use the [Vol] key to adjust the displayed calibration point until it matches the average weight obtained in step 2. Store this number by pressing the [Enter] key. The new calibration setting is confirmed by the “CAL” and “SET” messages on the display.
5. Verify this new calibration setting by repeating Steps 1 and 2.

D.2.3 “CALC” Mode

To calibrate the pipettor:

1. Weigh out ten aliquots of distilled water on an analytical balance, using one pipetting channel. The programmed dispense volume must correspond to the calibration point for that pipettor (*for example, 200µl for a 250µl pipettor*). Refer to Table D.2.2, Calibration Specifications, for proper calibration points.

Note: Ensure that the distilled water used is at room temperature (20-22.5°C).

2. Calculate display volume of the pipettor: $D_V = \frac{V_p}{V_a} \times C_p$
- V_p = Programmed Volume
- V_a = Corrected Actual Volume (corrected for temperature)
- C_p = Calibration Point (*each pipettor handle has a unique calibration point, see table D.2.2: Calibration Specifications.*)
- D_V = Display Volume
3. Enter the CAL mode on the pipettor by pressing the Special Function key (*use a pipet tip to press the key*) until “EASY” appears on the display.
4. Press the [Vol] key to display “CALC” (*pressing the [Vol] key again will return you to the “EASY” mode*).
5. Press the [Enter] key to display the calibration point.
6. Press the [Vol] key to enter the Display Volume (D_V) calculated above in step 2.
7. Press the [Enter] key to set the calibration point. The display shows “CAL” then “SET” to confirm the new calibration point, and returns to the current pipetting program.

Example: Calibrate a 1250 μ l 8-channel pipettor.

Water temperature = 24°C

Programmed Volume (V_p) = 1000 μ l

Average of Actual Volume = 990 μ l

Corrected Actual Volume (V_a) = 990 x 1.004 = 994 μ l

Calibration Point (C_p) = 1000

$$D_V = \frac{V_p}{V_a} \times C_p$$

$$D_V = \frac{1000\mu\text{l}}{994\mu\text{l}} \times 1000$$

$$D_V = 1006$$

D.2.4 CALVIEW

CALVIEW displays the pipetting stroke (number of steps) used to reach the calibration point. This value allows you to confirm the calibration during pipetting and after calibration. To activate CALVIEW, enter the CAL mode using the Special Function key. When the calibration point is displayed, press the [Fill] key. The number of steps is displayed. Press any key to exit CALVIEW.

D.2.5 CALRESET

CALRESET allows you to return to a default calibration step. To reset the calibration, enter the CAL mode using the Special Function key. When the calibration point is displayed, press the [Purge] key. The display flashes “FACT,” “CAL,” then “SET” and the pipettor resets to the default step. This default setting is an average value for all pipettors of its class. **This value may differ from the factory-optimized calibration step documented on the “Accuracy and Precision Verification” certificate enclosed in this pipettor’s documentation.** (See section D.2.2, Calibration Specifications).

D.3 Recommendations for Accurate Pipetting

*Impact*² pipettors are factory calibrated to deliver accurate volumes with distilled water at 21°C and 50% humidity. By using the calibration procedures described above, you can pipet liquids of different specific gravity with a high degree of accuracy and reproducibility. For optimal pipetting results, refer to the following recommendations:

- **Pipette at constant a temperature.** Allow liquids and equipment to equilibrate to ambient temperature. Volume aspiration with air displacement pipets varies with air pressure, relative humidity and the liquids vapor pressure, all of which are temperature dependent.
- **Attach tips with slow even pressure.** When applying tips, avoid ‘banging’ or applying excessive force to the tip(s), as this stretches the tip seal and will affect volume. Use Matrix tips which have been specifically designed to match the tip fittings on Matrix pipettors.

- **Calibrate the pipettor for the liquid.** If the liquid has a specific gravity and vapor pressure equivalent to distilled water, calibrate using “EASY” CAL mode. Otherwise, use “CALC” mode.
- **Pre-wet the pipet tip.** Aspirate and dispense a few times before aspirating the liquid to increase humidity within the tip, reducing sample evaporation that results in lower dispense volumes in initial few pipettings. The need to pre-wet increases when working with liquids with low vapor pressure and/or high surface tension.
- **Immerse tips fully.** Tips should be immersed approximately 1/4 inch (*approx. 0.6 cm*) below the liquids meniscus and away of the container surfaces to avoid aspiration of air and excess droplets clinging to the outside of the tip.
- **Discard a primer volume.** When the motor changes from aspiration to dispense, the percentage of error is greater in the first dispense than in subsequent dispenses.
- **Pause consistently.** It takes a moment for the liquid in the tip to finish moving. Pause with the tip in the liquid for about one second after aspirating the sample to allow the liquid to finish moving into the pipet tip after the pipettor stops. Otherwise, the volume will be lower than it should.
- **Aspirate slow, dispense fast.** As a general rule, pipet liquids, especially viscous, at a slower speed to ensure accurate pipetting. Dispense at faster speeds to expel liquid more accurately.

Note: *At the end of any dispense, remove pipet tips before releasing the trigger, to prevent aspiration of fluid.*

- **Tip touch.** During the dispensing of a liquid, touch the tip against the side of the receiving container to prevent any liquid from remaining on the tip.
- **Discard final dispense.** When accurate dispensing of several increments of liquid are needed, discard the last increment. The cumulative percentage of error from previous increments exists on the last volume. (*i.e. The pipettor aspirates 100µl and dispenses 20µl five times, and if each of the first four dispenses were off by +1.0µl, then the last dispense is missing 4µl before you even dispense it*).

E. TROUBLESHOOTING

Possible procedural and system problems, as well as recommended solutions. If you cannot resolve the problem, call Matrix Technologies Technical Service Department at **888-363-6631**.

No power to the pipettor.

Probable Cause	Recommended Solution
Batteries are incorrectly installed.	Recheck the orientation of the batteries; they should match the diagram in the battery case
Battery pack cables are not properly connected.	Ensure the connections to the battery pack are securely plugged into the connection from the pipettor body.
Battery Spacer is not in unit or is not in correctly (<i>Multichannels only with NiMH</i>).	Ensure that the battery spacer is in place for all models that use Nickel Metal Hydride (<i>see section F.3.1</i>).

Double beep tone «)» occurs.

Probable Cause	Recommended Solution
An illegal programming step is being entered, such as programming two fills that exceed the maximum fill volume.	Recheck the programming sequence. Ensure you are not attempting to fill above the maximum fill volume of the pipettor, or attempting to dispense more than the total fill volume.

“ERR_1” is displayed. (*Signifies one of the following conditions*)

Probable Cause	Recommended Solution
Pipettor cannot complete automatic blowout. Batteries are low on power, causing the motor to stall.	Recharge the batteries immediately. (<i>See Section F.4, Charging/Recharging Batteries</i>).
Liquid is aspirated into the pipettor.	Disassemble and clean the pipettor. (<i>See Section F.1 and/or F.2, for pipettor cleaning and autoclaving instructions</i>).
Motor is defective or the flex circuit assembly is damaged.	Contact Matrix Technical Service Department at: 888-363-6631

The motor sounds rough and aspiration is very slow.

Probable Cause	Recommended Solution
The pipettor has been set to the slowest speed	Verify speed setting, the slowest speed setting normally causes the motor to run slowly and louder than usual.
Motor has not been used for an extended period.	Cycle the unit (<i>fill and dispense</i>) five to seven times to re-lube the piston.

After reassembly, the pipettor leaks or does not fill liquid.

Probable Cause	Recommended Solution
O-ring was not properly seated.	Disassemble the pipettor and reseal the O-ring. (See Section F.1 and/or F.2 for pipettor disassembly/reassembly).
O-ring was damaged during reassembly.	Replace the O-ring. (See Section E.2.2, Pipettor Cleaning and Autoclaving (Relubrication step) and Section E.2.3, Pipettor Reassembly).
Cylinder was not screwed tightly into the pipettor body. (<i>single channel only</i>)	Securely screw the cylinder into the pipettor body, finger-tightened.

Pipettor does not eject pipettor tip properly.

Probable Cause	Recommended Solution
During reassembly of the collet and ejector sleeve, the metal ejector trigger tab was not correctly positioned behind the plastic tab of the ejector sleeve. (<i>Single channel only</i>)	Reassemble the collet and ejector sleeve with the correct orientation of the ejector trigger tab to the ejector sleeve tab. (See Section F.1.3, Pipettor Reassembly).

F. MAINTENANCE

The *Impact*² family of pipettors has been specifically designed for serviceability, enabling the user to service instruments with relative ease. Under certain circumstances where on-site service is not feasible, the instrument may need to be returned to Matrix for repair (see Pipettor Service, Sections G.2 and G3).

The *Impact*² requires very little maintenance. The exterior of the pipettor can be cleaned periodically with a soft cloth moistened with methyl alcohol. Periodic cleaning of the tip fitting and ejector sleeve may be necessary, using the procedures for maintenance listed below.

In cases where pipettors have been exposed to biohazardous materials, autoclaving internal components is required. Matrix Technologies provides the following Preventive Maintenance/Autoclave Kit:

Preventive Maintenance/Autoclave Kit

- Replacement cross tubes
- O-ring lubricant
- Wooden applicator
- O-rings

Item #	Description	Item #	Description
9809	12.5µl - 6, 8, & 12 channel	9805	1250µl - 6 & 8 channel
9801	125µl - 6, 8, & 12 channel	9803	12.5µl - 16 channel
9802	250µl - 6, 8, & 12 channel	9806	30µl - 16 channel
9804	850µl - 12 channel	9807	125µl - 16 channel

CAUTION! DO NOT AUTOCLAVE entire unit or clean the keypad with bleach solution or other solvents. Extreme heat can damage the display and other electronic components. Caustic cleaning solutions can damage the keypad.

Note: For autoclaving specific portions of the pipettor refer to the autoclaving steps in Section F.1.2 for single channel pipettors, or section F.2.2 for multichannel pipettors; or call Matrix Technical Service Department for instructions.

Note: Avoid prolonged exposure to ultraviolet light. The pipettor housing may become discolored or damaged.

F.1 Single Channel *Impact*² Maintenance

F.1.1 Single Channel *Impact*² Disassembly

With proper use of the pipettor, the disassembly and cleaning of the pipettor tip is not necessary. However, if fluid is inadvertently drawn into the tip fitting, then the lower end of the pipettor should be disassembled for thorough cleaning.

To disassemble the lower end of the pipettor:

1. Detach the collet by twisting it counter-clockwise (see Figure F.1.1a).
2. Remove the collet and ejector sleeve by sliding both pieces down over the cylinder (see Figure F.1.1b). For reassembly later, note the position of the large spring in the collet.

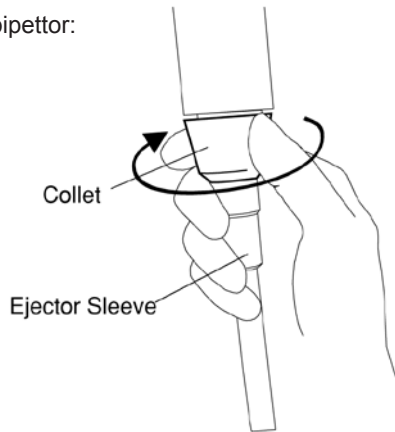

Figure F.1.1a: Detaching the Collet

3. Unscrew cylinder counter-clockwise and remove it from the pipettor body.

Note: Check for the presence of the o-ring on the piston. If it is not on the piston, look inside the cylinder and remove the o-ring.

4. Remove O-ring, O-ring support, and 1/2" diameter spring for cleaning by sliding them off of the the piston (refer to Figure F.1.1c).

IMPORTANT! Leave the piston on the motor screw, **DO NOT** try to disassemble!

Note: Check for the presence of the O-ring on the piston. If it is not on the piston, look inside the cylinder and remove the O-ring.

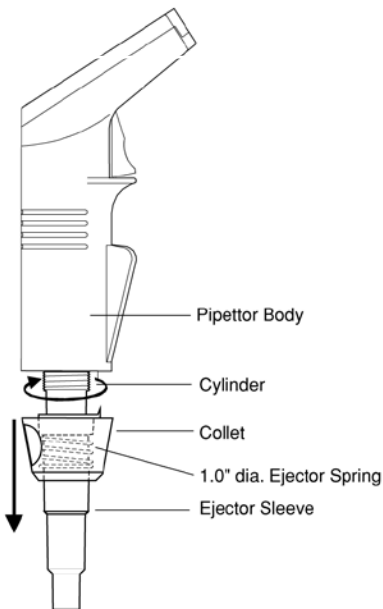

Figure F.1.1b:
Pipettor Tip Disassembly

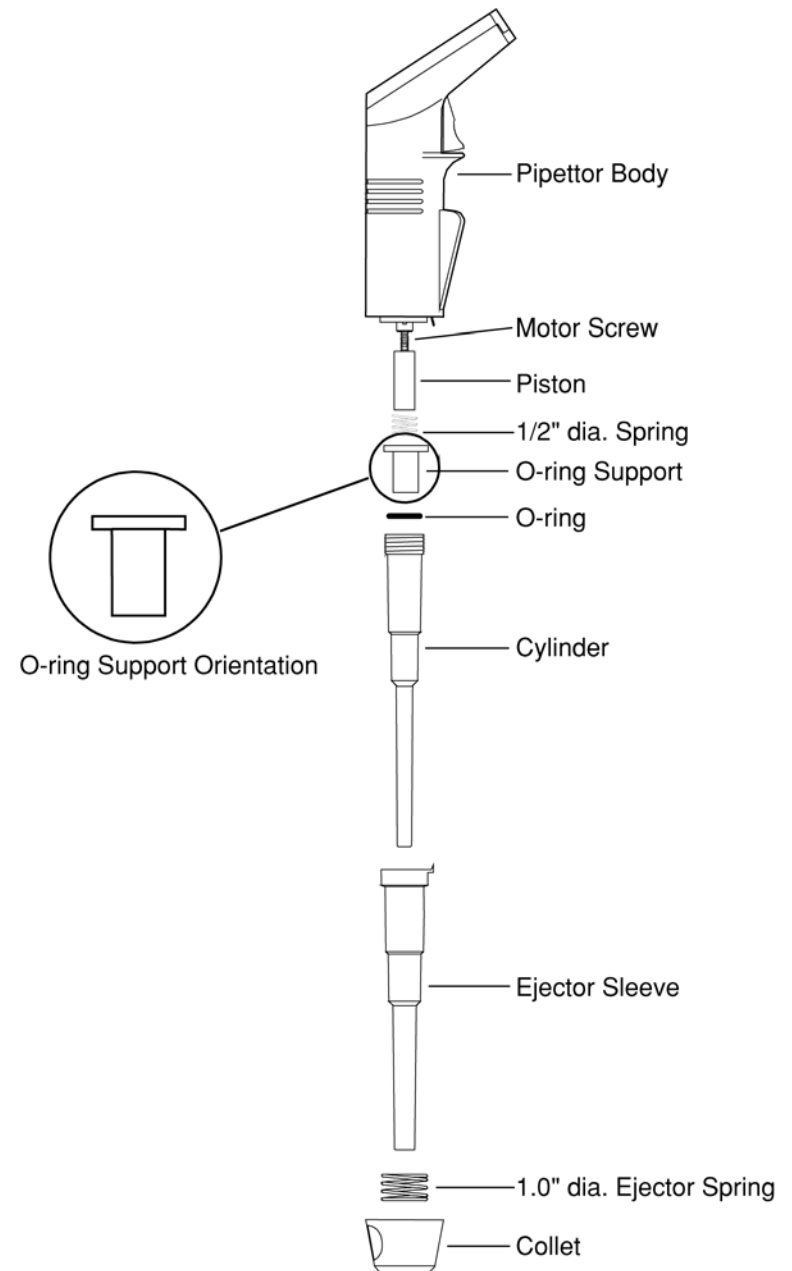

Figure F.1.1c: Pipettor Tip Assembly

F.1.2 Single Channel Cleaning and Autoclaving

General Cleaning:

Carefully wipe down all disassembled plastic and metal parts with methyl alcohol or 70% isopropyl alcohol.

Decontamination/Autoclaving:

Decontaminate all disassembled parts by wiping them with a bleach solution (5% sodium hypochlorite) or by autoclaving the parts at 121°C for 20 minutes.

Re-lubrication:

Lightly coat piston with O-ring lubricant and replace or re-install O-ring on the piston, as described in reassembly procedure.

Note: Do not clean the O-ring. Replace the O-ring after decontamination or autoclaving (O-ring and O-ring lubrication is available from Matrix Technical Service).

F.1.3 Pipettor Reassembly

After cleaning or decontaminating the disassembled parts, the pipettor can be reassembled (refer to Figure F.1.1c for parts identification and reassembly order).

1. Slide the 1/2" diameter spring, O-ring support, and O-ring over the piston and motor screw. (see Figure F.1.3a).
2. Slide the cylinder over the O-ring and piston assembly and screw into the pipettor body so that it is finger tight. Do not over tighten.
3. Assemble collet, 1.0" diameter ejector spring, and ejector sleeve.

Note: Ensure the tab on the ejector sleeve is aligned with the notch in the collet.

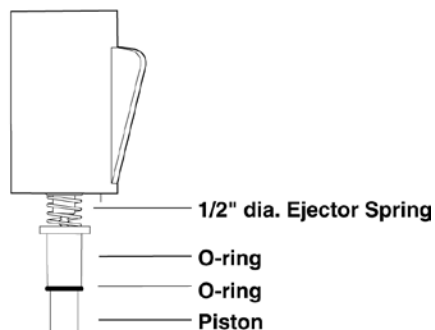

Figure F.1.3a: O-ring and piston assembly

4. Slide the collet, with spring and ejector sleeve, over the cylinder. Position the metal tab of the ejector trigger behind the tab on the ejector sleeve (see Figure F.1.3b).

5. Attach the collet onto the pipettor body by twisting left slightly, then right, to insert the tabs of the pipettor body into the locks on the collet (see Figure F.1.3b).

6. Test the ejector function to ensure that the ejector sleeve moves down when the ejector trigger is pressed.

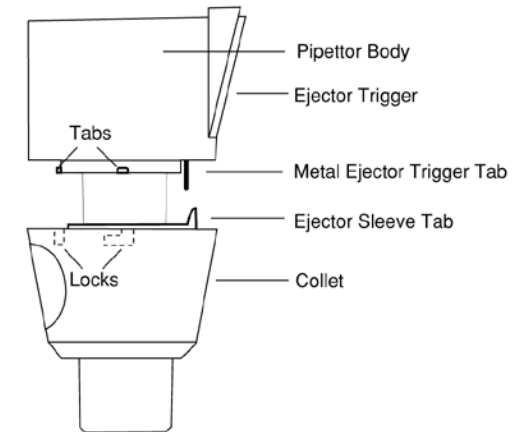

Figure F.1.3b: Detaching the Collet

F.2 Multichannel Impact² Maintenance

F.2.1 Multichannel Impact² Disassembly

1. Remove the color ring by gently prying loose one of the edges near the handle trigger.
2. Use a Phillips screwdriver to remove all three housing screws.
3. Carefully remove the plastic cover housing and observe the layout of the internal parts.

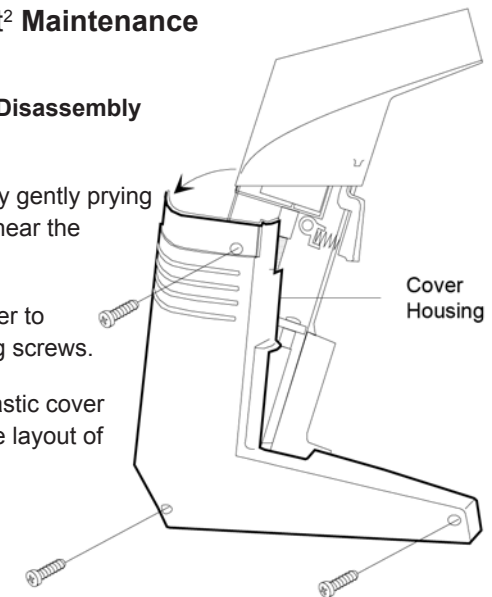

Figure F.2.1a: Removing Cover Housing

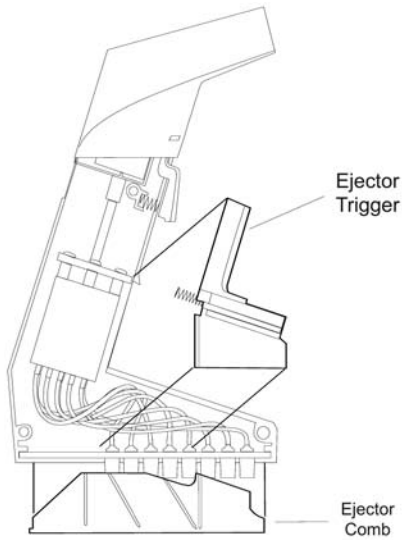

Figure F.2.1b: Removing Ejector Trigger and Ejector Comb

4. Remove plastic ejector trigger with spring and slide the aluminum ejector comb off of the tip fittings (see Figure F.2.1b). On 16 channel models, reverse this process and remove comb first, then trigger.
5. Remove the piston/cylinder assembly by pulling the motor screw down from the motor shaft coupling and out of the main housing. Remove the manifold assembly by firmly lifting it out of the main housing support ribs (see Figure F.2.1c).

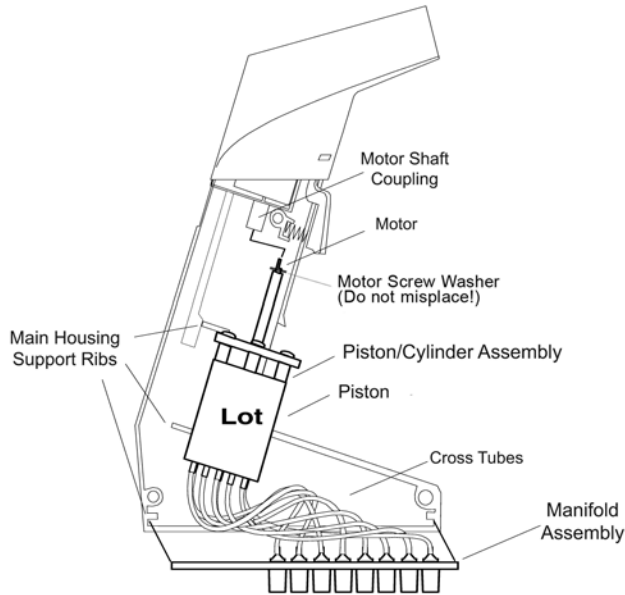
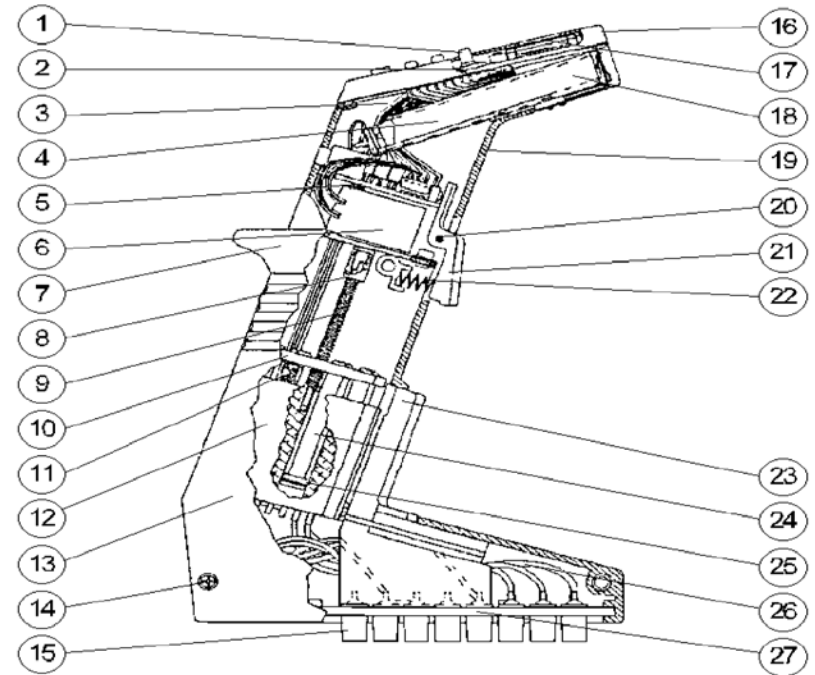

Figure F.2.1c: Removing Piston/Cylinder and Manifold Assemblies



Item	Description	Item	Description
1.	Keypad	15.	Tip fitting
2.	Main board	16.	Console cover
3.	Flex circuit	17.	Console display
4.	Battery box	18.	Batteries
5.	Driver board	19.	Main housing
6.	Motor	20.	Trigger hinge pin
7.	Color ring	21.	Handle trigger
8.	Motor coupling	22.	Handle trigger spring
9.	Motor screw	23.	Ejector trigger
10.	Piston backplate	24.	Piston
11.	Photosensor	25.	O-ring
12.	Cylinder	26.	Cross tube
13.	Cover housing	27.	Manifold plate
14.	Housing screw		

Figure F.2.1d: Pipettor Components

F.2.2 Multichannel Cleaning and Autoclaving

1. Remove the piston assembly from the cylinder.
2. Remove and discard the cross tubes into a biohazardous container.

3. Remove the O-rings (*only if necessary, see section F.1 and/or F.2 for O-ring Replacement*) and discard them into a biohazardous container.

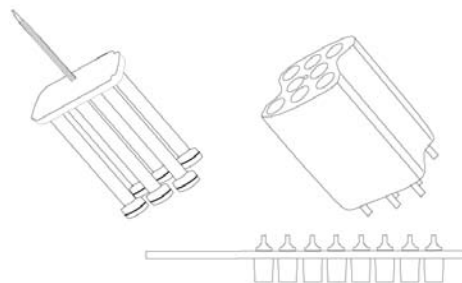

Figure F.2.2:
Components to be Autoclaved

4. Place all components (see Figure F.2.2) into the autoclave and autoclave at 121°C for 20 minutes.

F.2.3 Multichannel Maintenance and Reassembly

Once components are autoclaved and completely dry, use the following procedures to relubricate and reassemble the unit:

O-ring Replacement

The O-rings may require replacement if liquids have been over aspirated. In this case, the O-rings should be removed prior to autoclaving. Spare O-ring packs are available through Matrix for all pipettor volumes.

1. Remove old O-rings.

- **1250µl, 850µl, 250µl Pipettors:** O-rings can be removed from the pistons by squeezing one side of the O-ring and lifting it out of the O-ring groove on the piston. Once removed, the O-rings should be discarded as biohazardous waste.
- **125µl, 30µl, 12.5µl Pipettors:** O-rings from these pipettors are located in the cylinder. To remove the O-rings, unscrew the four screws that hold the cylinder cap to the cylinder (see Figure F.2.3a). Once removed, the O-rings should be discarded as biohazardous waste.

2. **Install new O-rings.** After the old O-rings have been removed and all components have been autoclaved, the new O-rings may be installed. Before installing the O-rings, apply a thin coat of lubricant to each O-ring, using the O-ring lubricant supplied in the Preventive Maintenance/Autoclave Kit.

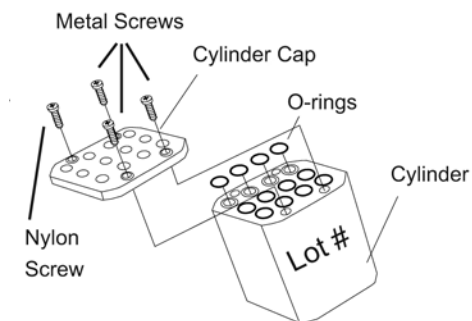

Figure F.2.3a: Removing O-rings

Re-lubrication

- **1250µl, 850µl, 250µl Pipettors:** Use the wooden applicator and O-ring lubricant supplied in the Preventive Maintenance/Autoclave Kit to apply a thin layer of lubrication approximately 0.5 inches (*approx. 1.3 cm*) down into each piston hole that requires it.

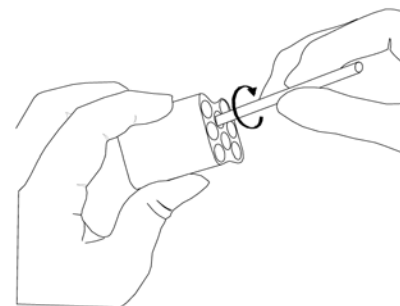

Figure F.2.3b:
Re-lubricating 1250 - 250µl Pipettors

Spread the lubricant evenly along the inner wall of each cylinder by using a circular motion with the wooden applicator (see Figure F.2.3b).

- **125µl, 30µl, 12.5µl Pipettors:** Spread the lubricant directly onto the pistons, approximately 0.5 inches (*approx. 1.3 cm*) from the bottom of each piston (see Figure F.2.3c)

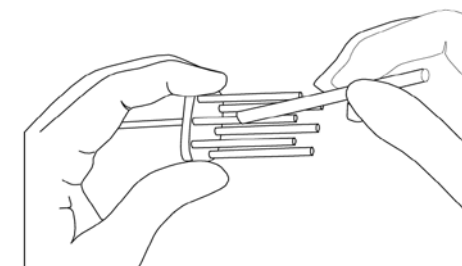

Figure F.2.3c:
Re-lubricating 125 - 12.5µl Pipettors

Reassembly

1. Reinsert the piston assembly into the lubricated cylinder. Ensure that the motor screw engages into the hole in the center of the cylinder (see Figure F.2.3d).

NOTE: To correctly orient the piston and cylinder assembly, ensure that the lot number of the cylinder is facing up and the painted section of the piston backplate is facing down. Also, care should be taken to keep the O-rings from being pinched when inserting the pistons into the cylinder.

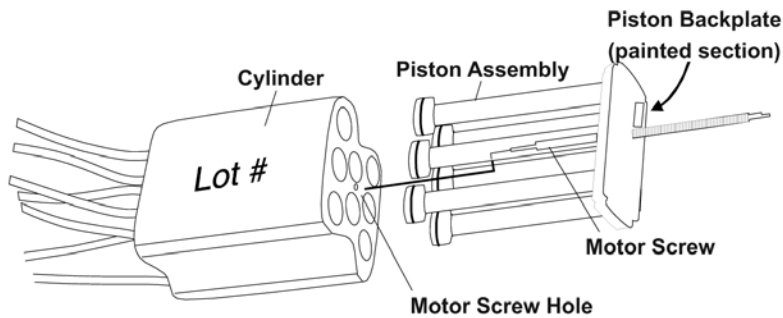

Figure F.2.3d: Reassemble Piston/Cylinder Assembly

2. Cross Tube Replacement

Refer to the following figure and table for proper connection of cross tubes from the tip fittings to the cylinder positions.

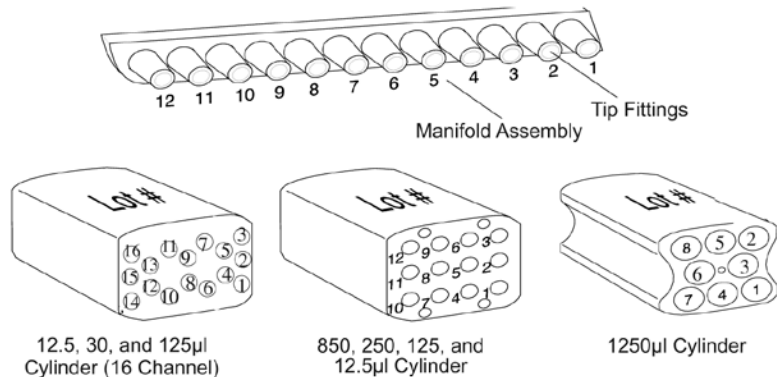

Table F.2.3a: Cylinders

Tip Fitting Positions															
1	2	3	4	5	6	7	8	9	10	11	12	13	14	15	16

Cylinder Positions																
16 Channel	1	2	3	4	5	6	7	8	9	10	11	12	13	14	15	16

16 Ch

12 Channel	1	2	3	4	5	6	7	8	9	10	11	12				
8 Channel	1	3	4	6	7	9	10	12								
6 Channel	1	2	3	10	11	12										
5 Channel	1	2	3	10	11											

12 Ch Cylinder

8 Channel	1	2	3	4	5	6	7	8								
6 Channel	1	3	4	6	7	8										
5 Channel	1	3	4	5	7											

8 Ch Cylinder

Table F.2.3b: Cylinder/Cross Tube Positions

Note: If the Cross Tube orientation between the cylinder and Tip Fittings is incorrect, reassembly of the pipettor will be impaired.

3. Carefully insert the flat end of the motor screw into the hole of the motor coupling. This can be accomplished by holding the piston/cylinder assembly at a slight angle while inserting the motor screw into the hole of the motor coupling. Slowly spin the motor screw until the flat end of the motor screw is fully engaged into the motor coupling hole (see Figure F.2.3e). The cylinder can now be seated between the plastic ribs in the main housing.

NOTE: The lot number on the face of the cylinder should be facing toward you and the painted section of the piston backplate should be facing the photosensor. The painted section is used by the photosensor to track the location of the pistons.

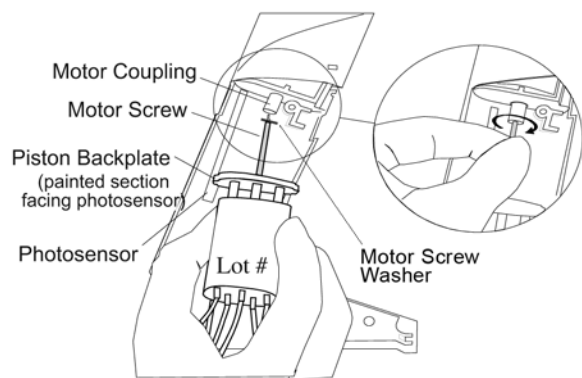

Figure F.2.3e: Installing Piston/Cylinder Assembly

4. After installing the piston/cylinder assembly, install the manifold assembly into the main housing. To keep the tubing free from ejector contact, rotate the manifold plate and tubing one complete turn counterclockwise (see Figure F.2.3f). Insert the manifold assembly into the main housing support ribs.

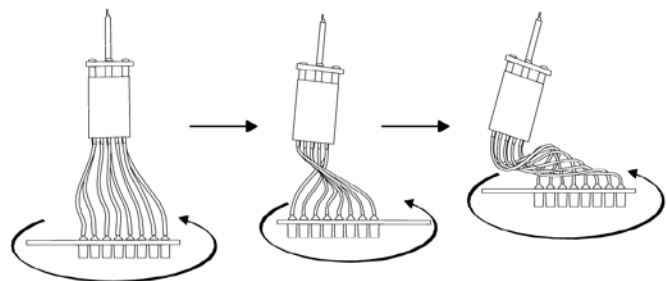

Figure F.2.3f: Rotating Manifold Assembly

5. Slide the ejector comb over the tip fittings with the slots on the back of the comb exposed (see Figure F.2.3g).

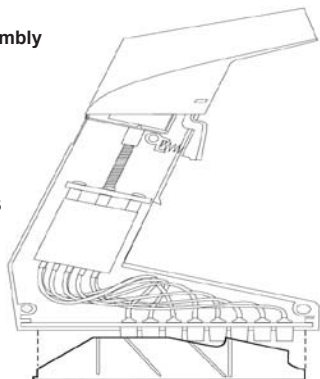

Figure F.2.3g: Attaching Ejector Comb

6. Hold the ejector comb in place while inserting the ejector trigger (see Figure F.2.3h). Place the end of the ejector spring against the plastic stop and compress the spring while positioning the ejector trigger over the aluminum ejector comb (the ribs on the ejector trigger should mate with the slots on the aluminum ejector comb). For 16 channel models, install the trigger prior to connecting the ejector comb.

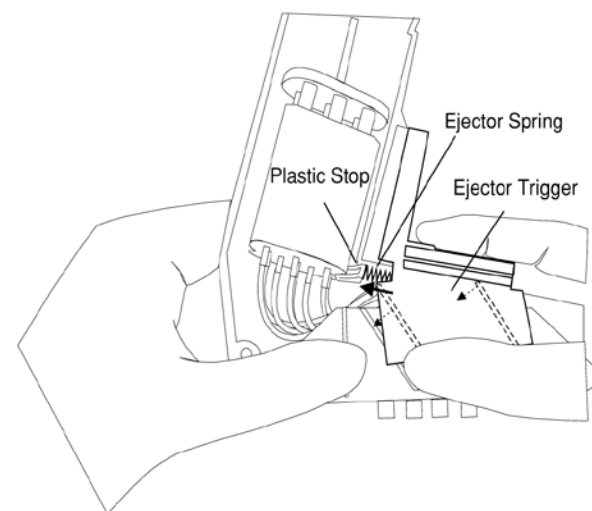

Figure F.2.3h: Inserting Ejector Trigger

NOTE: Be careful not to pinch the cross-tubes when inserting the ejector trigger.

Test the ejector trigger to ensure that the ejector comb moves down when the trigger is pressed (hold the ejector comb firmly in place while testing the trigger).

7. Place the cover housing onto the main housing and fasten the three screws.
8. Re-attach the color ring.
9. Test pipettor for smooth operation. (Reassemble and repeat steps 3-7 if necessary.)

The pipettor is now ready for use.

F.3 Installing/Replacing Batteries

The *Impact*² comes with rechargeable Nickel Metal Hydride (NiMH) batteries or with a Lithium Ion battery for 16 channel models. Under normal use, the batteries can be recharged approximately 400-500 times. When they can no longer hold their charge, the batteries must be replaced. Replacement batteries can be purchased through the Matrix Technical Service Dept. The pipettor may also be returned to Matrix for battery replacement.

Replacement batteries:

6, 8, 12 Multichannels	2 NiMH	Item No.: 6092
Single Channel	1 NiMH Pack	Item No.: 2092
16 Channel only	1 Lithium-Ion Battery	Item No.: 2094

Note: When replacing batteries, ensure the pipettor is turned off before removing the battery case.

F.3.1 Installing/Replacing Nickel Metal Hydride Batteries

F.3.1A Installing/Replacing Single Channel *Impact*² Batteries

1. Remove screws. Use a small, flathead screwdriver to remove the two screws holding the top of the pipettor (containing the display and keypad) to the pipettor housing. The screws are located just above the pipetting trigger (see Figure F.3.1Aa).

2. Lift pipettor top. Carefully lift the top of the pipettor to expose the battery pack.

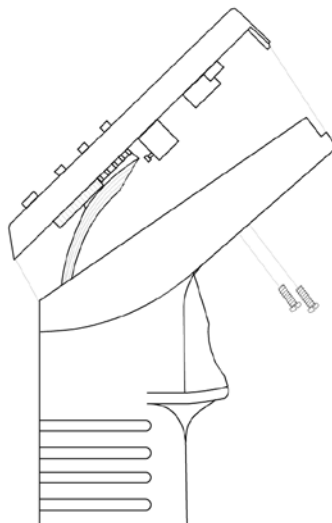

Figure F.3.1Aa:
Removing Pipettor Cover

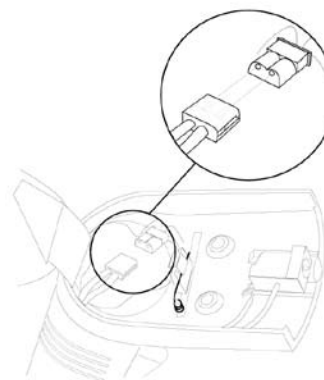

Figure F.3.1Ab: Disconnect Wires

3. Disconnect wire connectors. Pull apart the two wire connectors over the battery pack (see Figure E.3.1Ab).

4. Remove battery pack. Pull gently on the battery wire connector (without the pins) to dislodge the battery pack, then lift the battery pack out of the main housing (see Figure F.3.1Ac).



Figure F.3.1Ac:
Remove Battery

5. Insert new battery pack.

Insert the new battery pack into the cavity of the main housing. Ensure that the wire is looped under the battery pack and the connector is above it (refer to Figure F.3.1Ac).

NOTE: The battery pack fits very snugly in the main housing; therefore, ensure that the pack is oriented as shown in Figure F.3.1Ac. The connectors for the battery pack and the pipettor should be on opposite sides.

6. Reconnect wire connectors.

Reconnect the wire connectors above the battery pack. Gently push the wires of the battery pack down until the wire connectors lay flat over the top of the battery pack.

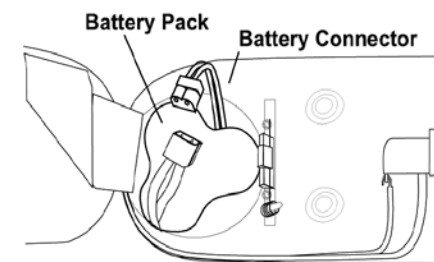

Figure F.3.1Ad: Reconnect Wires

7. Reassemble pipettor top.

Attach pipettor top to the main housing. Ensure flex cable is behind the top of the pipettor trigger and the trigger contacts the limit switch properly (see Figure F.3.1Ae). Fit the edges of the pipettor top snugly within the edges along the top of the pipettor housing. Ensure that the cables to the power jack are inside the main housing well below the edges to avoid pinching the cables. Hold assembly together firmly while resecuring the two screws.

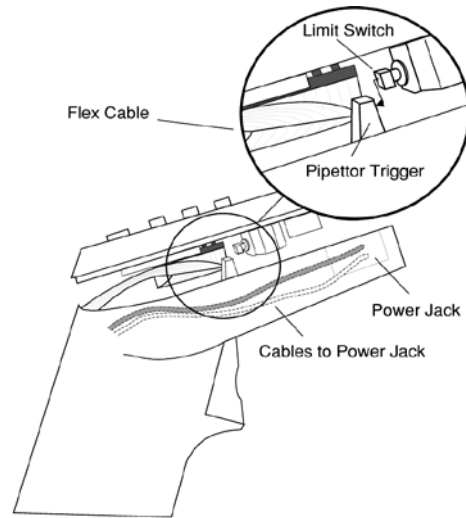

Figure F.3.1Ae:
Assembling Pipettor Top

8. Recharge batteries. Recharge the new batteries before using the pipettor (see Section F.4, Recharging Batteries).

F.3.1B Installing/Replacing Multichannel *Impact*² Batteries

The *Impact*² pipettor is shipped with Nickel Metal Hydride batteries packaged separately. Install the batteries and recharge them for 14-16 hours. Use the following procedure to install the batteries, then continue to Section F.4, Recharging Batteries.

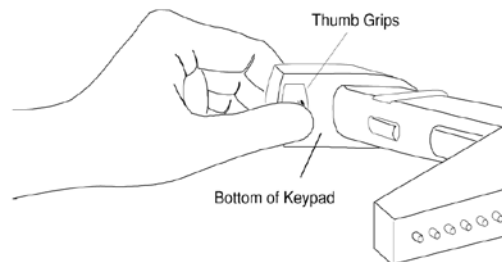

Figure F.3.1Ba: Removing Battery Case

1. Remove battery case. Position your thumb over the thumb grips (see Figure F.3.1Ba) and brace your fingers against the front of the keypad. Apply firm pressure to the panel with the thumb grips to release the latch.

2. Remove batteries. Press a pipet tip against either battery through the slot in the bottom of the battery case to remove the batteries (see Figure F.3.1Bb).

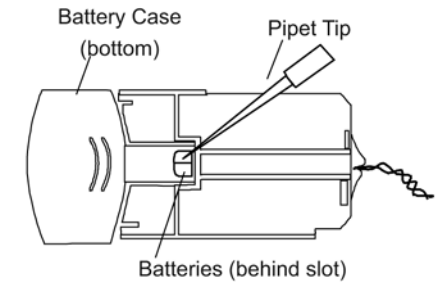

Figure F.3.1Bb: Opening the Case

3. Install new batteries. Insert the spacer into the bottom of the battery box (as shown in Figure F.3.1Bc). Insert new batteries by placing the positive end into the battery case first, then the negative end in place over the spacer (an exploded view of the assembly is shown in Figure F.3.1Bc, or the diagram in the battery case). Ensure that the batteries are correctly oriented.

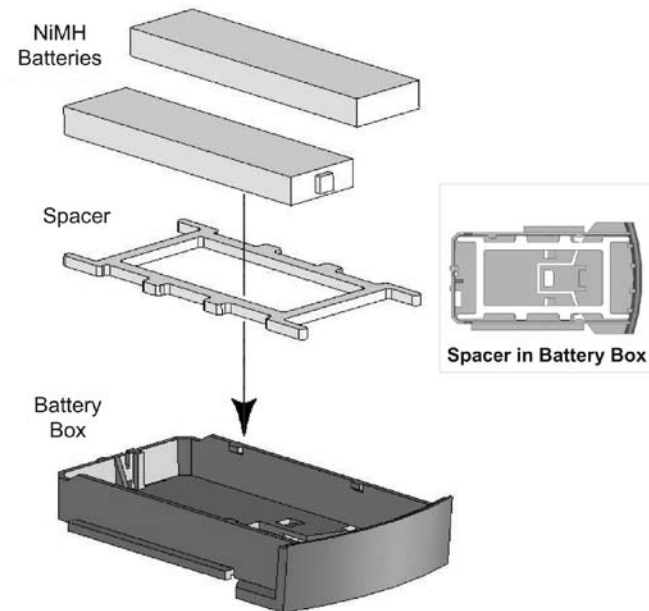

Figure F.3.1Bc: Installing NiMH Batteries

F.3.2 Installing/Replacing Lithium-Ion Battery (16 Channel *Impact*²)

Your *Impact*² pipettor is shipped with a Lithium-Ion Battery. Before using the pipettor, charge it for 2 hours. Use the following procedure when installing new batteries. Otherwise, continue to Section F.4, Recharging Batteries.

- 1. Remove battery case.** Position your thumb over the thumb grips (see *Figures F.3.2a,b*) and brace your fingers against the front of the keypad. Apply pressure to the panel with the thumb grips to release latch. Carefully slide battery case out of the pipettor, allowing sufficient slack for attached wires of the battery.



Figure F.3.2a:
Battery Case (Closed)



Figure F.3.2b:
Battery Case (Open)

- 2. Remove Console Cover.** Unclip the two snaps on console cover assembly, then unhook the end of console cover assembly (see *Figures F.3.2c,d*).

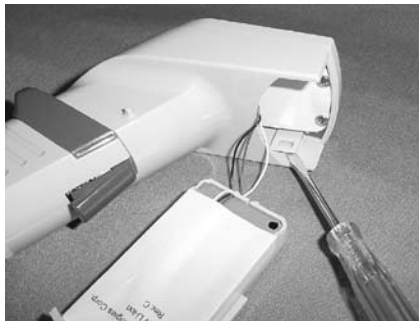

Figure F.3.2c: Unclip Snaps



Figure F.3.2d: Unhook Cover

- 3. Carefully Remove Console Cover.** Press and lift off console cover assembly (see *Figure F.3.2e*). BE CAREFUL not to tear the attached flex cable! (Refer to *Figure F.3.2f*).



Figure F.3.2e: Remove Console Cover

- 4. Unclasp Battery Connector.** Lift one side of battery connector with a small flathead screwdriver. Grasp all three wires and pull out connector (see *Figures F.3.2f,g*).



Figure F.3.2f:
Lift Battery Connector



Figure F.3.2g: Unclasp Battery Connector

5. Connect New Battery. Attach the wires of the new battery in place of the old battery.

6. Reassemble Console Cover. Attach the pipettor top to the main housing. Ensure that the flex cable is behind the top of the pipettor trigger and the trigger contacts the limit switch properly (refer to Figures F.3.2a thru F.3.2g as needed). Fit the edges of the pipettor top snugly within the edges along the top of the pipettor housing. Ensure the cables to the power jack are inside the main housing, well below the edges, to avoid pinching the cables.

F.4 Charging/Recharging Batteries

F.4.1 Charging/Recharging Nickel Metal Hydride (NiMH) Batteries

The *Impact*² uses two Nickel Metal Hydride (NiMH) rechargeable batteries, located in a battery case under the keypad. The batteries are charged in the pipettor by using the power transformer included in the package, with the exception of single channel pipettors which do not have this ability. You can operate the pipettor while it is recharging; or you can operate it solely with the power transformer (without batteries). The batteries can be recharged approximately 400-500 times. To extend battery life, the pipettor will turn off automatically if it is not used within ten minutes.



Note: Battery charge is low when the battery symbol appears on the display. The pipettor will continue to function, but should be recharged at the earliest convenient time.

1. Attach transformer. Attach the cable end of the transformer into the pipettor. The plug receptacle is above the color ring. Plug the transformer into the electrical outlet.

2. Recharge batteries. Recharge batteries for 14-16 hours to ensure a full charge. After the batteries have been recharged, unplug the pipettor from the transformer.

Note: Batteries hold their maximum charge if they are fully discharged before recharging again. However, overnight recharging is acceptable if the pipettor is in normal use during the day.

CAUTION! Avoid excessive charging of the batteries when the pipettor is not in use. Excessive charge to the batteries will shorten the battery life and may damage the batteries.

F.4.2 Charging/Recharging Lithium-Ion Battery (16 Channel *Impact*²)

The *Impact*² uses a Lithium-Ion rechargeable battery, located in a battery case under the keypad. The battery is charged while it is in the pipettor by using the power transformer included in the package. The pipettor can be operated while it is recharging; or it can be operated solely with the power transformer (*with no battery*). The battery can be recharged approximately 400-500 times. To extend battery life, the pipettor will turn off automatically if it is not used within ten minutes.



Note: Battery charge is low when the battery symbol appears on the display. The pipettor will continue to function, but should be recharged at the earliest convenient time.

Rapid Charge - When the low battery indicator appears (*on the pipettor LCD display screen*) the battery should be charged for 1.5 to 2 hours to achieve a full charge. Refer to the following table for partial charge times:

Amount of Charge	Time
80%	1.25 hour
95%	1.5 hours
100%	2 hours max

The battery pack for the 16 Channel *Impact*² features an indicator light to indicate the state of charge of the battery while plugged into the power supply. With the unit plugged in, the indicator operates as follows:

- **Green** - Indicates that the power supply is connected.
- **Orange** - Indicates charging (*charge current into the battery*).
- **Flashing Orange to Green** - When the battery is fully drained the indicator will remain a solid orange for a while as the battery requires constant charge current.

As the unit continues to charge, charge current is supplied in pulses. This is indicated by the pulsation of the indicator. As the battery nears full charge the pulsation will slow down becoming nearly a constant green. When the battery is fully charged the indicator will be almost a constant green, flashing only about once every 3-5 seconds to ensure the battery stays topped off with full charge. The battery is now in a fully charged state.

Note: *The typical life expectancy of the battery is approximately 400-500 full recharges. To prolong this and attain the maximum usage from the battery it is recommended to recharge the battery whenever it is not being used instead of waiting until the 'Low-Bat' symbol appears. Completely draining the battery will not shorten the life expectancy. However, recharging before fully discharged will prolong the battery life.*

CAUTION! Avoid excessive charging of the batteries when the pipettor is not in use. Excessive charge to the batteries will shorten the battery life and may damage the batteries.

CAUTION! The battery pack and power supply for 16 channel

*Impact*² is not interchangeable with the power supply and battery pack of other *Impact*² models. The power jack/connector and battery connector are different to prevent the mating with other *Impact*² models.

G. TECHNICAL SERVICE

G.1 Instrument Warranty

This instrument is warranted to the original purchaser by Matrix Technologies Corporation to be free of defects in materials or workmanship for a period of 12 months from the date of purchase, providing that it has been operated according to the instructions, not abused or misused, that the serial number has not been removed, and that the instrument has not been disassembled, other than for procedures for normal maintenance. No other warranty is expressed or implied, including the warranty of merchantability.

No instrument should be returned without a prior Return Goods Authorization from Matrix. Should a unit need to be returned, the purchaser must pay insurance and shipping charges. Matrix Technologies will assume the cost of returning the repaired unit to the purchaser. This product's packaging is capable of withstanding normal shipping hazards. If an instrument needs to be repaired, please return it to us in its original shipping carton, if possible.

Contact Matrix Technical Service for recommended equipment decontamination methods (*see also section G.4*), or to obtain repairs or replacements within the term of the above warranty at **(888) 363-6631**, **fax: (603) 577-7682**.

For Europe and Asia locations, please visit:
<http://www.matrixtechcorp.com>

G.2 On Site Service - Calibration & Maintenance

At Your Service

On-site, expert pipettor preventive maintenance and calibration services.

Certified Matrix-trained technicians calibrate and service most manual and electronic pipettor brands and models – Matrix, Biohit, Rainin, Eppendorf, Gilson, Oxford, and more.

Basic Calibration

- Physical pipettor inspection.
- Leak test.
- Replacement of o-ring and seal, as needed.
- Gravimetric performance validation using NIST-traceable balance.
- Performance validation of 5 aliquots at two volumes verified against performance specifications stated in ISO 8655 standard.
- Calibration adjustment, as needed.
- Performance validation report.

Preventive Maintenance and Custom Calibration is available upon request.

Schedule a Clinic Today!

If you have 50 or more Pipettors,
Call 1.888.363.6631 or e-mail technicalservice@matrixtechcorp.com
today to arrange a clinic.

Each person who brings 20 pipettors to the clinic receives a free gift!

Matrix Service Pledge

Our technical experts set the benchmark in pipettor service. If a pipettor fails validation on-site, we will offer to repair it at our facility and, if necessary, deal with the original manufacturer to ensure any major repairs are completed properly.

No hassle or pressure – it's Matrix service.

Matrix and the Matrix logo are registered trademarks of Matrix technologies Corporation. All trademarks and product names are the intellectual/industrial property of the respective owners.

MATRIX
fluid thinking.

www.matrixtechcorp.com

22 Friars Drive, Hudson, NH 03051

MATRIX
Impact²

G.3 Factory Service - Calibration, Maintenance, & Repair

Expert Pipettor Service

Trusted Service

- Certified, Matrix-trained technicians calibrate & repair most pipettor brands and models.
- Matrix has 20-plus years manufacturing & servicing manual and electronic pipettors.
- Broad range of services to fit every need: Basic Calibrations, Essential Preventive Maintenance, and Repair Service.

Streamlined Process

- Matrix's specially designed pipettor shipping boxes are convenient and offer high visibility.
- Streamlined documentation features one form with service options, decontamination certification, and shipping details.
- Contact your Matrix representative or call 800.345.0206 to have pre-addressed and pre-paid pipettor shipping boxes delivered right to your door.

Pipettor Shipping

Matrix's calibration service combines superior service and fast turnaround to get your pipettor operating at peak performance without delay.

Send one or multiple pipettors, using the packaging and carrier of your choice.

Accuracy & Precision

- Single Channel pipettors are qualified with 5 aliquots verified on NIST-traceable gravimetric balances at two volumes.
- Multichannel pipettors are qualified with 5 aliquots verified gravimetrically at high and low volumes using one channel. The precision of the pipettor is measured by a spectrophotometric absorbance verification. This added test will allow you to see the performance of each channel of your multi channel pipettor as it dispenses the lowest test volume across a microplate.
- The accuracy and precision of each pipettor will be verified in a temperature and humidity controlled environment to meet the performance specifications stated in the ISO 8655 standard. Additionally, if you require "as received" performance data or ISO compliant testing protocols, Matrix will gladly provide custom calibration services upon request.

MATRIX
Impact²

G.4 Recommended Equipment Decontamination Methods

The following table lists the proper decontamination procedures for returning equipment to Matrix for service.

Product/Component	Heat at 65°C/ 10 Hr.	70%/30% IPA/Water	10% Bleach	Ethylene Oxide	Autoclave 121°C/ 15 min.
Multi Impact/ Impact², EXP, EQUALIZER, 16 CHANNEL					
Pipettor Exterior	YES	Wipe	Wipe	YES	NO
Piston/Cylinder Assembly	YES	YES	NO	YES	YES
Tip Manifold	YES	YES	NO	YES	YES
Battery	NO	Wipe	NO	NO	NO
Power Supply	NO	Wipe	NO	NO	NO
Pipettor Exterior	NO	Wipe	Wipe	NO	NO
Single Ch. Impact/ Impact²					
Pipettor w/Battery Removed	Yes	Wipe	Wipe	YES	YES
Lower cylinder	YES	YES	YES	YES	YES
Piston (do not remove)	YES	YES	NO	YES	NO
Power Supply	NO	Wipe	NO	NO	NO
Electrapette					
Housing Exterior	YES	Wipe	Wipe	YES	NO
Power Supply	NO	Wipe	NO	NO	NO
Housing Exterior	YES	Wipe	NO	YES	NO
Memowell					
Power Supply	NO	Wipe	NO	NO	NO
Housing Exterior	YES	Wipe	NO	YES	YES
Manual Pipettor					
Lower assembly	YES	Wipe	NO	YES	YES
Housing Exterior	YES	Wipe	Wipe	YES	NO
Cellmate II					
Nosecone	YES	YES	YES	YES	YES
Silicone Rubber Holder	YES	YES	Wipe	YES	YES
Filter	Replace	Replace	Replace	Replace	Replace
Battery	NO	Wipe	NO	NO	NO
Power Supply	NO	Wipe	NO	NO	NO
Housing Exterior	YES	Wipe	NO	NO	NO

WARNING: Do not expose batteries to temperatures above 60° C.

G.5 Equipment Decontamination Verification Form

Serial # _____
 RP# _____
 PO# _____

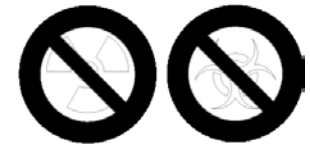

Prior to service of equipment that may be contaminated with biohazardous materials, potentially biohazardous materials or radioactivity, the user must first decontaminate it. This decontamination procedure will include the following as appropriate (please check one):

This equipment has not been used in a laboratory/location exposing it to biohazards or radioactive materials.

This equipment was APPROPRIATELY DECONTAMINATED* FROM BIOHAZARDOUS MATERIALS WITH:

*Example: Autoclave, 10% Bleach, Ethylene Oxide.
 Instruments must be decontaminated both externally and internally.

This equipment was APPROPRIATELY DECONTAMINATED & TESTED FOR RADIOACTIVITY* BY:

*Example: wipe test with results (3H, 14C,a-emitters), Geiger counts, etc.

NAME (print) _____
 PHONE # _____
 SIGNATURE _____
 DATE _____

Federal regulations require that all instruments sent for service shall be free of radioactivity and biohazards. The Technical Service group reserves the right to refuse to work on this equipment if these procedures are not performed.



Customer Return Shipping Address: _____

Return fax# 603-577-7682

FRM029 Rev. D

Safety Testing of our Products

The products listed below have passed the required safety tests for electrical products for the approvals and marks mentioned.

Product	Approval mark	Directive	Standard	Transformer Item #
Impact²		73/23/EEC Low Voltage	EN61010-1:1993 Safety regulations	6099, 6096, 1096, 1099, 9068
		89/336/EEC Electromagnetic compatibility	EN55022 / EN55011-1 Emissions EN50082-1:1992 Immunity	
		Law No.234, Electrical Appliance and Material Safety Law, Japanese Ministry of Economy, Trade and Industry.	EN60825	6098, 1098/1097, 9068
			DENAN	6098, 1098/1097, 9068

INDEX

A		M	
Autoclaving	34, 38	Maintenance (Multichannel)	35-43
Automatic blowout	7	Maintenance (Single channel)	32-35
B		Maintenance Procedures	31-52
Batteries, Installation (Lithium-Ion)	48	Mix	15
Batteries, Charging (Lithium-Ion)	51	Mix Key	7
Batteries, Charging (NiMH)	50	O	
Batteries, Installation (NiMH)	44	On/Off Key	6
Battery Case	5	Open Programming Mode	13-16
C		Operation Keys	6-7
CAL	9	P	
"CALC" Mode	25	PACE	9
Calibration (Procedures)	23-27	Paced Dispense	9, 22
Calibration ("CALC" Mode)	25	Pipetting Trigger	5
Calibration ("EASY" Cal)	24	Prog Key	6
Calibration (Specifications)	24	Program (Examples)	18-20
CALRESET	27	Program (Recall)	17
CALVIEW	27	Program (Storing)	16
Color Ring	5	Program Keys	7-8
D		Purge	15
Decontamination Form	57	Purge Key	7
Decontamination Methods	56	R	
Default Programming Volumes	14	RUN mode	7
Disp Key	7	S	
Dispense	14	Scratch Pad (Program 0)	13
Display	5, 10	SPd	10
E		Special Function Key	8-10
Ejector Trigger	5	Speed Adjustment	17
"EASY" Cal Mode	24	T	
Enter Key		Transformer Connector	5
F		Technical Service (In Factory)	55
Factory Calibration Step	24	Technical Service (On Site)	54
Fill	14	Tip Fittings	5
Fill Key	7	TONE	8
Hazards and Precautions	12	Troubleshooting	29
K		V	
Keypad	5, 6	Vol Key	8
L		Volume Range(s)	11
Lubrication	34, 40	W	
		Warranty	53

