



Thank you for purchasing iG5A Series Profibus Communication Module

SAFETY PRECAUTIONS

- Always follow safety instructions to prevent accidents and potential hazards from occurring.
- Safety precautions are classified into “WARNING” and “CAUTION” and their meanings are as follows:

 **WARNING** Improper operation may result in serious personal injury or death.

 **CAUTION** Improper operation may result in slight to medium personal injury or property damage.

- The indicated illustrations on the product and in the manual have the following meanings.

 Danger may be present. Read the message and follow the instructions carefully.

 Particular attention should be paid because danger of an electric shock may be present.

- Keep operating instructions handy for quick reference.
- Read the operating instructions carefully to fully understand the functions of the SV-iG5A series and to use it properly.

CAUTION

- **Be cautious, when handling the CMOS components of the communication module.**
Static may lead to malfunctioning of the product.
- **Turn off the inverter power, when changing the communication cable.**
Otherwise, you may damage the module or a communication error may occur.
- **Make sure to insert the Communication module connector to the inverter precisely.**
Otherwise, you may damage the module or a communication error may occur.
- **Check the parameter unit before setting up the parameter.**
Otherwise, a communication error may occur.

Table of Contents

Chapter 1. Overview	1
1.1 What are the Benefits of Using Profibus option module?	1
1.2 Unpacking the drive	1
Chapter 2. SV-iG5A Profibus Communication Option Module.....	2
2.1 Technical Data	2
2.2 Profibus Communication Option Module	3
2.3 Profibus Terminals	4
2.4 Control Terminals	5
2.5 Installation Procedure	6
2.6 Instruction for installation	7
2.7 Maximum distance according to the baudrate	8
Chapter 3. Status Diagnostic and LED Indication	9
3.1 LED Status Indicator	9
3.2 Option Module Diagnostics according to LED status	9
Chapter 4. Inverter Parameter	12
4.1 Profibus Communication Parameter List	12
4.2 Profibus Communication Parameters	14
4.2.1 Communication option module name – C1	14
4.2.2 Operation setting method - drv	14
4.2.3 Frequency setting method - Frq	14
4.2.4 Selection of operation in lost command - I62	14
4.2.5 Decision time for lost command - I63	15
4.2.6 Version of Profibus option module – C2	15
4.2.7 Station ID setting – C3	15
4.2.8 LED indication for communication status – C5	16
4.2.9 The number of Para Status setting – C30	16
4.2.10 Para Status 1~8 – C31~C38	17
4.2.11 Number of Para Control setting – C50	17
4.2.12 Para Control 1~8 – C51~C58	18
4.2.13 Comm UpDate – C99	19
Chapter 5. GSD File (Electronic Data Sheets).....	20

Chapter 1. Overview

This Profibus communication option module (abbreviated Profibus option module) allows a SV-iG5A inverter to be connected to Profibus network.

1.1 What are the Benefits of Using Profibus Option Module?

Profibus option module allows a controlling and monitoring of inverter to be controlled via sequence program of PLC or Profibus Master Module.

It helps to reduce the installation cost since multiple connections can be implemented with a communication line. In addition, the wiring is simple so installation time will be reduced and maintenance will be easier.

Factory automation can be easily implemented because it can control the inverter with auxiliary devices of PLC and operates with top devices as PC, etc.

1.2 Unpacking the Drive

The Profibus option module is delivered in a package that contains the following items.

- . Profibus Communication Option Module (1)
- . Profibus Communication Option Module User Manual (1)
- . Fixing Screw M3 (2)

Chapter 2. SV-iG5A Profibus Communication Option Module

2.1 Technical Data

Device Type	Profibus DP Slave
Auto Baudrate Detect	Supported mode
Synchronization Mode	Supported mode
Freeze Mode	Supported mode
Max. Input Length	8 words
Max. Output Length	8 words
Baudrate Support	9.6K, 19.2K, 93.75K, 187.5K, 500K, 1.5M, 3M, 6M, 12M
Modular Station	Supported
Max. Module	2
Max. Connectable Number of Nodes	Max. 32 nodes without repeater (including master module)
LED	3 LEDs (ONLINE, ERR, and CPU)
Communication Connector	5-pin removable connector

Table 1 Technical Data

2.2 Profibus Communication Option Module

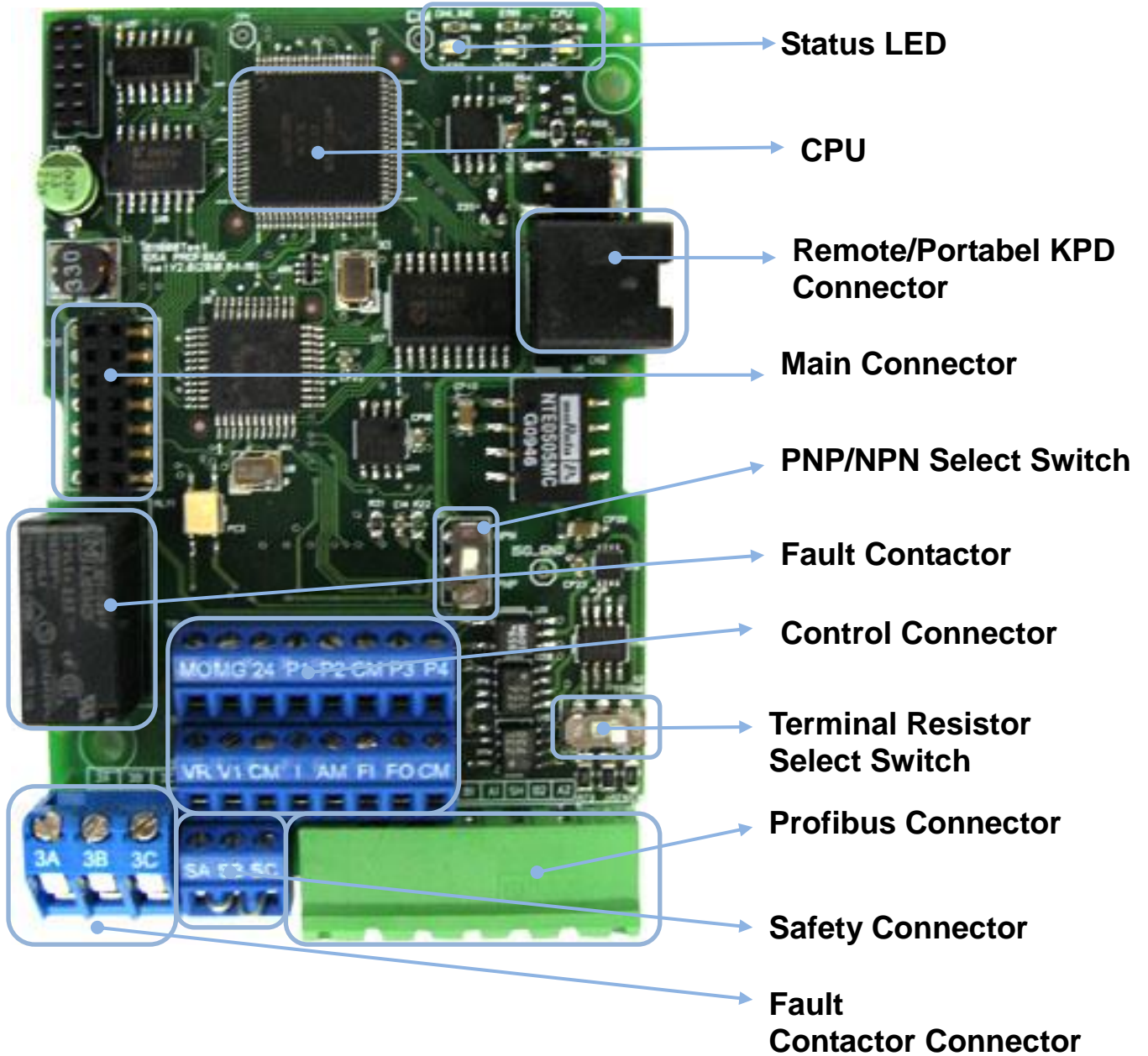

Figure 1 Profibus Communication Option Module

2.3 Profibus Terminals

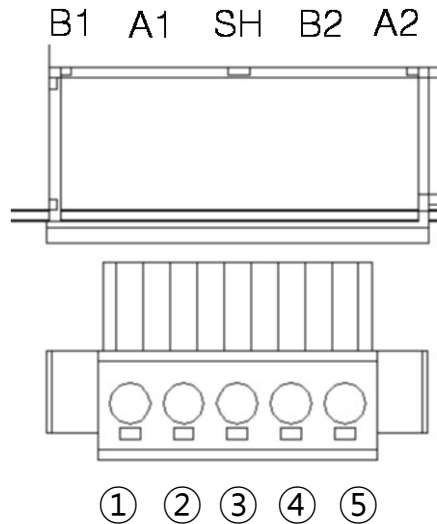

Figure 2 Profibus Terminals

No.	Signal	Description
1	B1	Send/Receive data Plus 1
2	A1	Send/Receive data Negative 1
3	SH	Shielded Ground
4	B2	Send/Receive data Plus 2
5	A2	Send/Receive data Negative 2

Table 2 Signal Description

2.4 Control Terminals

	MO	MG	24	P1	P2	CM	P3	P4
	VR	V1	CM	I	AM	FI	FO	CM
	SA	SB	SC					
Terminals	Names of Terminal			Electrical Information				
P1 ~ P4	Multi-function input terminal 1-4			-				
CM	Common terminal			-				
VR	Power supply for Aux. volume resistor			Output voltage: 12V Max. output current: 10mA Volume resistor: 1 ~ 5 k Ω				
V1	Voltage input terminal			Max. input voltage: -10V ~ +10V input				
I	Current input terminal			0 ~ 20mA input Internal resistor: 250 Ω				
AM	Multi-function analog output terminal			Max. output voltage: 11[V] Max. output current: 10mA				
MO	Multi-function terminal (Open Collector)			Below DC 26V, 100mA				
MG	Aux. power supply common terminal			-				
24	Aux. 24V power supply			Max. output current: 100mA				
3A	Multi-function relay output A			Below AC 250V, 1A				
3B	Multi-function relay output B			Below DC 30V, 1A				
3C	Multi-function relay common terminal			-				
FI	Pulse input terminal			0 ~ 50kHz				
FO	Pulse output terminal			0 ~ 7				
SA	Safety input command A			-				
SB	Safety input command B			-				
SC	Safety Power Supply			Max. output current: 10mA				

Table 3 Control Terminals Information

Note 1) Tie the control wires more than 15cm away from the control terminals. Otherwise, it interfere the reinstallation of front cover.

Note 2) Use copper wire rated 600V, 75 °C and higher.

2.5 Installation Procedure

- Remove the front cover (②, ③) of iG5A for Europe. Connect the Profibus option module (④) on the inner cover (⑤) of inverter.
- Mount the upper front cover (②) after connecting the profibus option module (④).
- Connect the communication and I/O signal cable to control the inverter.
- Fasten the screw on the upper front cover (③) after connecting cables.
- Profibus option module needs the Portable keypad (⑥) or Remote keypad for monitoring since the module is non-loader type.

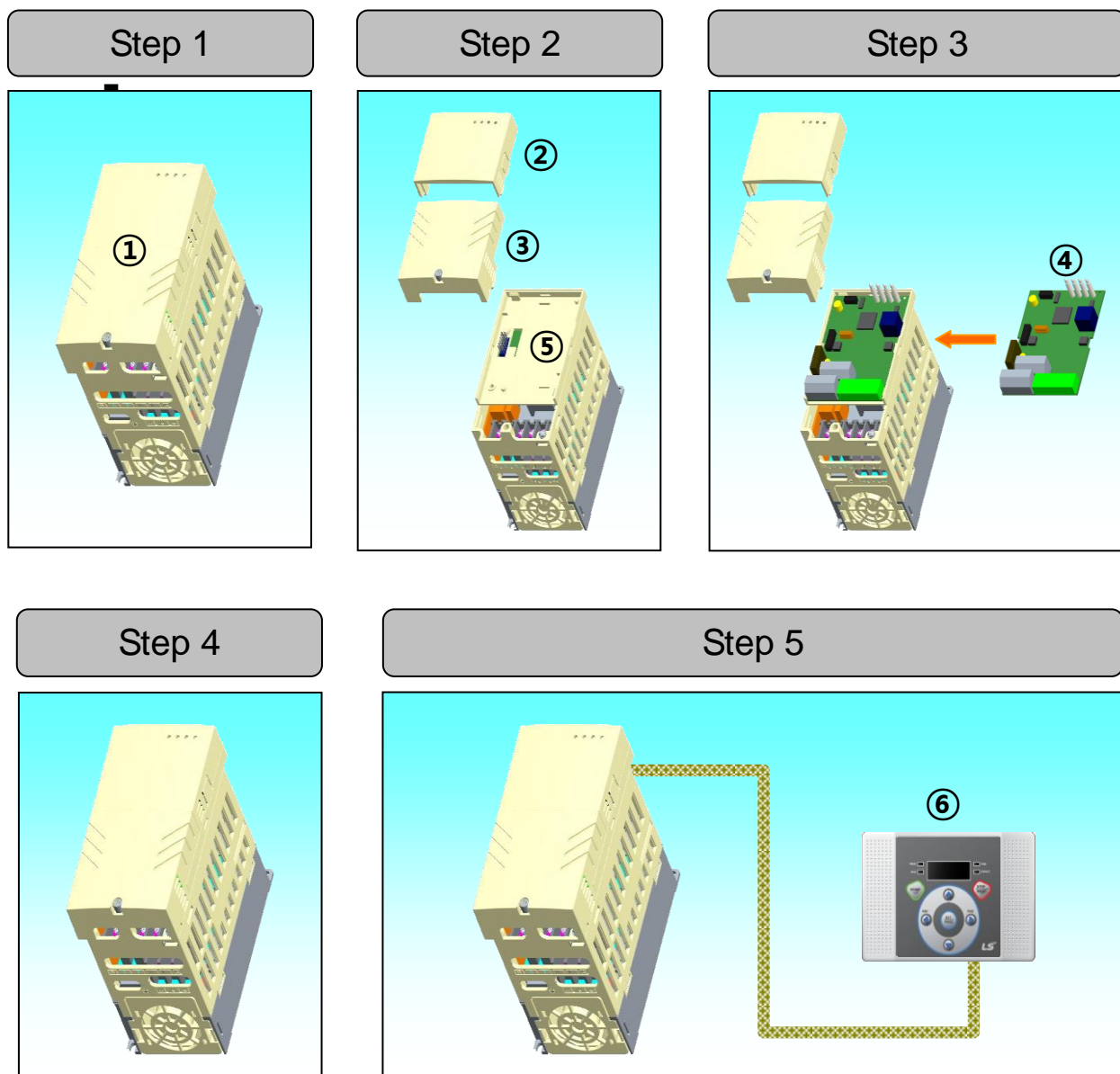

Figure 3 Installation Steps

2.6 Instruction for installation

Warning) Make sure that connect Profibus option module after inverter power is disconnected.

Do not install or remove Profibus option module while the power is ON. Otherwise, both Profibus option module and the inverter may be damaged. Install or remove Profibus option module when the condenser of the inverter has been fully discharged.

When building a network, make sure to connect the termination resistor to reduce the noise at Profibus option module at the end of the network. Turn on the termination resistor switch on Profibus option module. Termination resistor 220 Ω and 1/8W will be connected between A1 and B1.

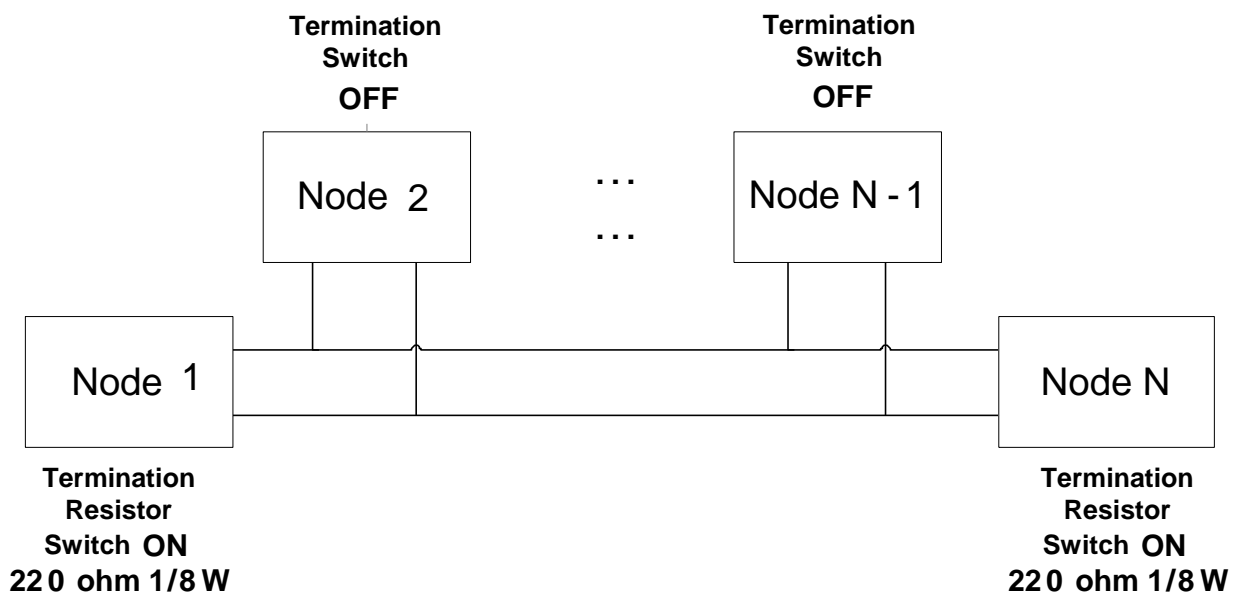

Figure 4 Termination Resistor

2.7 Maximum Distance according to the Baudrate

Total BUS length of network is differed according to the baudrate. The communication is not guaranteed if the total distance exceeds the total BUS length.

Baudrate	Max. Segment Length	Max. Extension Distance
12 Mbps	1,000 m / 3,278 feet	10,000 m / 32,786 feet
6 Mbps	1,000 m / 3,278 feet	10,000 m / 32,786 feet
3 Mbps	1,000 m / 3,278 feet	10,000 m / 32,786 feet
1.5 Mbps	1,000 m / 3,278 feet	10,000 m / 32,786 feet
500 kbps	400 m / 1,311 feet	4,000 m / 13,114 feet
187.5 kbps	200 m / 655 feet	2,000 m / 6,557 feet
93.75 kbps	100 m / 327 feet	1,000 m / 3,278 feet
19.2 kbps	100 m / 327 feet	1,000 m / 3,278 feet
9.6 kbps	100 m / 327 feet	1,000 m / 3,278 feet

Table 4 Maximum Distance according to the Baudrate

Chapter 3. Status Diagnostic and LED Indication

3.1 LED Status Indicator

Profibus Option Module have 3 kinds of LED. Refer to following table for troubleshooting information provided by there LEDs.

LED	Status	Description
CPU	Steady (On)	Power supply on the module OK after mounting the option module on the inverter.
ERR	Steady (On)	Module has a fault.
ONLINE	Steady (On)	Module is online.

Table 5 LED Indication

3.2 Diagnostics according to LED status

LED	LED Status	Option Module Status	Cause	Corrective Actions
CPU	OFF	Power supply fault	No power supply or connection fault between inverter and Profibus option module	<ul style="list-style-type: none"> ☞ Check power supply. ☞ Check fault function of inverter. ☞ Check connector connection between Profibus option module and inverter.
	Blinking every second	Normal	Normal operation	-
ERR	OFF	Normal	Normal operation	-

	Blinking every second with CPU LED	Communication error with inverter	Communication is not available between inverter and option module.	<ul style="list-style-type: none"> ☞ Check fault function of inverter. ☞ Check connector connection between Profibus option module and inverter.
	Blinking every 2 seconds	CONFIG ERROR	Configuration Data is incorrect setting between Master and Inverter.	☞ Check configuration information set in master and inverter.
ERR	Blinking every 3 second	Configuration information changed	Station ID, number of Status, and number of Control value is changed by Keypad.	☞ Perform Comm Update or reset the inverter if Station ID (C 3), number of Status (C 30), and number of Control (C 50) are changed.
ON-LINE	OFF	Off-Line	Communication is not started from master.	☞ Start the communication from Master.
			Communication connector has a fault.	☞ Check the connection between pin number of connector and termination resistor.
			There is no master in the network.	☞ There is no designated master or master has a fault.

			Wrong Station ID	<p>☞ Check the station ID between designated Profibus option module station ID set in configuration tool and station ID set in keypad of inverter. In addition, check that station ID is unique in the network.</p>
			Network Configuration Fault	<p>☞ Check that it exceeds max. length of segment.</p> <p>☞ Check that number of station exceeds 32 stations including repeater in a segment.</p> <p>☞ Check that the number of station exceeds 126 stations including repeater in a network.</p>
ON	On-Line	IO Data Exchange state	-	

Table 6 Diagnostics according to LED Status

Chapter 4. Inverter Parameter

4.1 Profibus Communication Parameter List

Code	Name of Parameter	Default Value	Range	Description
drv	Operation Setting Method	1. Fx/Rx-1	0. Keypad	Select No.4 FieldBus if you want to command the operation of inverter via Profibus.
			1. Fx/Rx-1	
			2. Fx/Rx-2	
			3. RS485	
			4. FieldBus	
Frq	Frequency Setting Method	0. Keypad-1	0. Keypad-1	Select No.9 FieldBus if you want to command the frequency of inverter via Profibus.
			1. Keypad-2	
			2. -10~10V	
			3. 0~10V	
			4. 0~20mA	
			5. "2" + "4"	
			6. "3" + "4"	
			7. RS485	
			8. Digital Volume	
			9. FieldBus	
10. Pulse				
C 1	FieldBus Option Name	-	-	'PnEt' is indicated when Profibus option module is mounted.
C 2	Comm. Option Module Version	-	-	S/W version of Profibus option module is indicated.
C 3	Station ID Setting	1	1 ~ 125	-
C 5	FBus LED	-	-	LED status of Profibus option module is displayed.

C30	Number of Para Status Setting	3	0~8	Set the number of Status used.
C31	Para Status-1	h000A	0~hFFFF	Set the address of status read from Profibus master.
C32	Para Status-2	h000E	0~hFFFF	
C33	Para Status-3	h000F	0~hFFFF	
C34	Para Status-4	h0000	0~hFFFF	
C35	Para Status-5	h0000	0~hFFFF	
C36	Para Status-6	h0000	0~hFFFF	
C37	Para Status-7	h0000	0~hFFFF	
C38	Para Status-8	h0000	0~hFFFF	
C50	Number of Para Control	2	0~8	Set the number of Control.
C51	Para Control-1	h0005	0~hFFFF	Set the address of control controlled by Profibus master.
C52	Para Control-2	h0006	0~hFFFF	
C53	Para Control-3	h0000	0~hFFFF	
C54	Para Control-4	h0000	0~hFFFF	
C55	Para Control-5	h0000	0~hFFFF	
C56	Para Control-6	h0000	0~hFFFF	
C57	Para Control-7	h0000	0~hFFFF	
C58	Para Control-8	h0000	0~hFFFF	
C99	Comm Update	0. No	0. No	Use when comm. update Profibus option module. '0' is displayed automatically after comm. update if C99 set to 1.
			1. Yes	
I62	Selection of Operation in Lost Command	0. None	0. None	Set the inverter operation when Lost Command is occurred.
			1. Free-Run	
			2. Dec	
I63	Decision Time for Lost Command	1.0 sec	0.1 ~ 120.0 sec	Set the decision time for Lost Command.

Table 7 Inverter Parameters

4.2 Profibus Communication Parameters

4.2.1 Communication option module name - C 3 FBus ID

It displays the name of option module installed on the inverter.

It displays 'PnEt' when Profibus option module is installed correctly and it has no fault.

4.2.2 Operation setting method - drv

It sets the operation setting method of inverter.

To control inverter operation through Profibus communication, set 'drv' to '4'.

4.2.3 Frequency setting method - Frq

It sets the frequency setting method of inverter.

To control inverter frequency through Profibus, set 'Frq' to '9'.

4.2.4 Selection of operation in lost command - I62

drv	Operation setting method
Frq	Frequency setting method
I62	Selection of operation in Lost Command
I63	Decision time for Lost Command

It designates operation method when communication is lost during decision time for Lost command. To use this function, 'drv' have to be set to '4' (FieldBus) or 'Frq' to '9' (FieldBus).

Selection of operation in Lost Command	
0 (None)	Continuing operation
1 (FreeRun)	Free run to stop
2 (Stop)	Deceleration to stop

4.2.5 Decision time for lost command - I63

To use this function, 'drv' have to be set to '4' (FieldBus) or 'Frq' to '9' (FieldBus).

drv	Operation setting method	If
Frq	Frequency setting method	
I62	Selection of operation in Lost Command	
I63	Decision time for Lost Command	

communication restarts in a decision time of Lost Command, it is not recognized for error. (①)

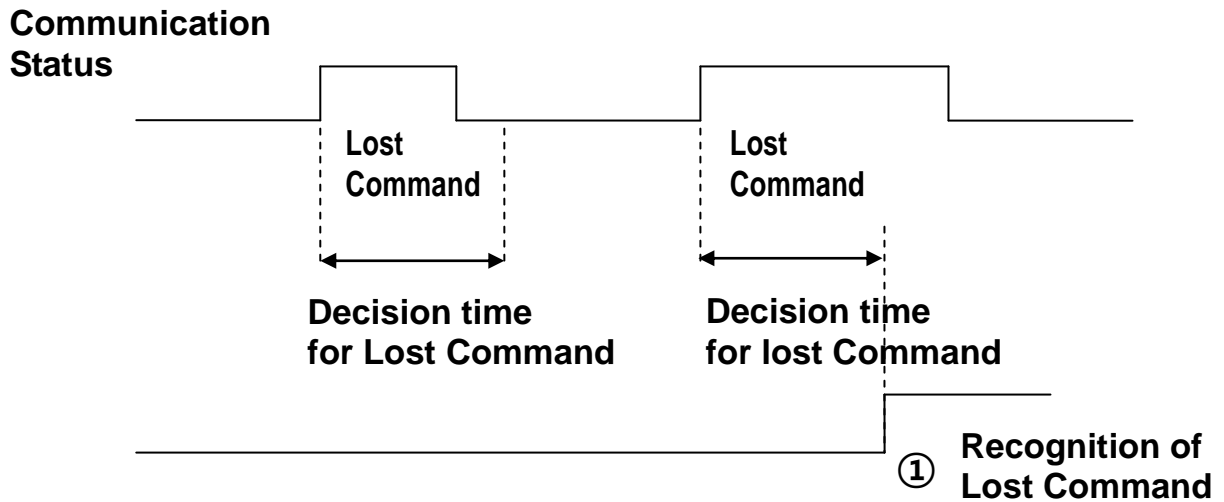

Figure 5 Lost Command Recognition

4.2.6 Version of Profibus option module – C2

It displays the version of Profibus option module installed on the inverter.

4.2.7 Station ID setting – C3

C3	Station ID setting
C99	Comm Update

It sets Station ID of Profibus option module. It can set station ID from 1 to 125. Station ID cannot be duplicated. Check if Station ID is not

duplicated in the network. If station ID is changed, ERR LED on the Profibus option module is flickered every 3 seconds.

The number of changed Para Control must be applied to Profibus option module. Set C99 (Comm Update) to '1' when Station ID had been changed.

4.2.8 LED indication for communication status – C5

Profibus communication option module have 3 LEDs, (blank), ONLINE, ERR, and CPU, on the keypad in order from left to right. It indicates communication status by On/Off.

C5 Status Example) 0101

LED type	Blank	ON-LINE (Green)	ERR (Red)	CPU (Green)
Keypad Value	0	1	0	1
Status	Reserved	ON	OFF	ON

4.2.9 The number of Para Status setting – C30

C30	Number of Para Status setting
C31~C38	Para Status1~Status8 setting

This parameter determines that inverter sends how many status information to master through Profibus communication.

It can set the number from 0 to 8. Para Status has to be set as the number of Para Status. (from C31 to C38 as preset number)

For example, If C30 sets to '3', Para Status set from C31 to C33. If C30 sets to '6', Para Status set from C31 to C36.

If C30 (the number of Parameter status) is changed, ERR LED on Profibus option module is flickered every 3 seconds.

If 'Number of Para Status setting' is changed, set 'C99(Comm Update)' to '1' to apply the changed number of Para Status to Profibus option module.

4.2.10 Para Status 1~8 – C31~C38

C30	Number of Para Status setting
C31~C38	Para Status1~Status8 setting

It determines that what status information will be sent to master through Profibus communication.

Para Status 1~8 sets with the type of inverter address. The address is for inverter common area and inverter keypad parameter. If keypad parameter address is used, it will be inputted the type of (h0A x h1000) + ('Group number' x h100) + ('Code number').

For example, if maximum frequency of No. 21 at F group set to Para Status-1, it has to be set to hA215.

$$h0A \times h1000 + h02 \times h100 + h15(\text{Dec } 21) = hA215$$

Group	Group Number
DRV	1
F	2
H	3
IO	4
COM	5

4.2.11 Number of Para Control setting – C50

C50	Number of Para Control setting
C51~C58	Para Control 1 ~ Control 8 setting
C99	Comm Update

It determines that master sends how many control information to inverter through Profibus communication.

It can set the number from 0 to 8. Para Control has to be set as the number of Para Control. (From C51 to C58 as preset number)

For example, If C50 sets to '2', Para Status set from C51 to C52. If C50 sets to '5', Para Status set from C51 to C55.

If C50 (the number of Para Control) is changed, ERR LED on Profibus option module is flickered every 3 seconds.

If 'Number of Para Control setting' is changed, set 'C99(Comm Update)' to '1' to apply the changed number of Para Control to Profibus option module.

4.2.12 Para Control 1~8 – C51~C58

C50	Number of Para Control setting
C51~C58	Para Control 1~Control 8 setting

It determines that what control information will be sent to inverter through Profibus communication. Para Control 1 ~ 8 sets with the type of inverter address. The address is for inverter common area and inverter keypad parameter. If keypad parameter address is used, it will be inputted the type of (h0A x h1000) + ('Group number' x h100) + ("Code number"). For example, if maximum frequency of No.34 at IO group set to Para Control-1, it has to be set to hA422.

$$h0A \times h1000 + h04 \times h100 + h22 \text{ (Dec 34)} = hA422$$

Group	Group Number
DRV	1
F	2
H	3
IO	4
COM	5

4.2.13 Comm UpDate – C99

C3	Station ID setting
C30	The number of Para Status setting
C50	The number of Para Control setting
C99	Comm UpDate

After changing Station ID, the number of Para Status, and the number of Para Control, set the Comm Update to '1'.

The changed value will be applied to Profibus option module after Comm Update.

Chapter 5. GSD File (Electronic Data Sheets)

It contains the information of Profibus option module. The profibus configuration software needs GSD file.

You can download GSD file from technical support in LSIS website.
(<http://eng.lsis.biz>)

Warranty

Maker	LS Industrial Systems Co., Ltd.		Installation Date	
Model No.	SV-iG5A Profibus Communication Option Module		Warranty Period	
Customer Information	Name			
	Address			
	Tel.			
Sales Office (Distributor)	Name			
	Address			
	Tel.			

Warranty period is 12 months after installation or 18 months after manufactured when the installation date is unidentified. However, the guarantee term may vary on the sales term.

IN-WARRANTY service information

If the defective part has been identified under normal and proper use within the guarantee term, contact your local authorized LS distributor or LS Service center.

OUT-OF WARRANTY service information

The guarantee will not apply in the following cases, even if the guarantee term has not expired.

- ▶ Damage was caused by misuse, negligence or accident.
- ▶ Damage was caused by abnormal voltage and peripheral devices' malfunction (failure).
- ▶ Damage was caused by an earthquake, fire, flooding, lightning, or other natural calamities.
- ▶ When LS nameplate is not attached.
When the warranty period has expired.