



SIDE BY SIDE REFRIGERATOR



OWNER'S MANUAL AND INSTALLATION

CONTENTS

<i>SAFETY WARNING</i>	2
<i>OPERATING INSTRUCTIONS</i>	4
SETTING UP THE REFRIGERATOR.....	4
MAJOR FEATURES.....	4
CONTROL PANEL.....	5
DIGITAL PANEL.....	7
TEMPERATURE CONTROL	8
ICE AND COLD WATER DISPENSER.....	8
SHELVES AND BINS	9
FOOD STORAGE GUIDE	10
CoolSelect Zone™ Drawer GUIDE.....	12
REMOVING FREEZER ACCESSORIES	14
REMOVING REFRIGERATOR ACCESSORIES	14
BEVERAGE STATION™ (optional).....	15
CLEANING ACCESSORIES.....	16
CHANGING THE INTERIOR LIGHT	16
WATER FILTER	17
DOORS.....	17
<i>INSTALLATION INSTRUCTIONS</i>	18
INSTALLATION OF THE REFRIGERATOR	18
REMOVING THE REFRIGERATOR DOORS.....	19
REATTACHING THE REFRIGERATOR DOORS	22
ADJUSTING THE CLEARANCE BETWEEN THE DOORS	25
CHECKING THE WATER DISPENSER LINE.....	27
INSTALLING THE WATER DISPENSER LINE.....	28
TROUBLESHOOTING	33

SAFETY WARNING



- Before operating the appliance, please read this manual thoroughly and retain it for your reference.
- Because these following operating instructions cover various models, the characteristics of your refrigerator may differ slightly from those described in this manual
- The appliance is not intended for use by children or infirm persons without adult supervision.
- Children should be supervised to ensure that they do not play with the appliance.

CAUTION/WARNINGS USED

 WARNING	Indicates that a danger of death or serious injury exists.
 CAUTION	Indicates that a risk of personal injury or material damage exists.

OTHER SIGNS USED

	Represents something you must NOT do.
	Represents something you must NOT disassemble.
	Represents something you must NOT touch.
	Represents something you must follow.
	Indicates that you must disconnect the power plug from the socket.
	Represents a ground is needed to prevent electric shock.
	It is recommended that this sentence be handled by service man.

WARNINGS

- Do not plug several appliances into the same multiple power board.**
 - This could cause overheating and the risk of fire.

Make sure that the power plug is not squashed or damaged by the back of the refrigerator .

 - A damaged power plug may overheat and cause fire.

Do not directly spray water inside or outside the refrigerator/ freezer.

 - There is a risk of electric shock.

Do not use aerosols near the refrigerator .

 - There is a risk of explosion or fire.

Do not bend the power cord excessively or place heavy articles on it .

 - This constitutes a fire hazard. If the power cord is damaged, have it replaced immediately by the manufacturer or its service agent.

Do not insert the power plug with wet hands.

 - You may receive an electric shock.

Do not put a container filled with water on the refrigerator.

 - If spilled, there is a risk of fire or electric shock.

Do not install the refrigerator in a damp place or a place where it may come in contact with water.

 - Deteriorated insulation electrical parts may cause electric shock or fire.

Do not store volatile or flammable substances in the refrigerator.

- The storage of benzene, thinner, alcohol, ether, LP gas and other such products may cause explosions.

Do not disassemble or repair the refrigerator by yourself.

- You run the risk of causing a fire, malfunctions and/or personal injury.

Pull the power plug out of the socket before changing the interior light of the refrigerator.

- Otherwise, there is a risk of electric shock.

If you wish to dispose of the refrigerator / freezer throw it away after first removing the doors and seals.

- Do so in a way, that is not possible for a child to remain trapped inside.

The refrigerator must be grounded.

- You must ground the refrigerator to prevent any power leakages or electric shocks caused by current leakage from the refrigerator.

Never use gas pipes, telephone lines or other potential lightning rods as ground.

- Improper use of the ground plug can result in electric shock.

SAFETY WARNING



CAUTIONS



Do not overfill the refrigerator with food.

- When you open the door, an item may fall out and cause personal injury or material damage.

Do not put bottles or glass containers in the freezer .

- When the contents freeze, the glass may break and cause personal injury.

If the wall socket is loose, do not insert the power plug.

- There is a risk of electric shock or fire.



Do not disconnect the power cord by pulling on it.

- Damage to the cord may cause a short-circuit, fire and/or electric shock.
- If the power cord is damaged, it must be replaced by the manufacturer, a certified service agent or qualified service personnel.

Do not store articles on the top of the appliance .

- When you open or close the door, the articles may fall and cause personal injury and/or material damage.

Do not store pharmaceuticals products, scientific materials or temperature-sensitive products in the refrigerator.

- Products that require strict temperature controls must not be stored in the refrigerator.

Do not let children hang on the door. If not, a serious injury may occur.

If you smell pharmaceuticals or smoke, pull out the power plug immediately and contact your SAMSUNG Electronics service center.



Do not touch the inside walls of the freezer or products stored in the freezer with wet hands.

- This may cause frostbite.

Do not insert your hands into the bottom area under the appliance.

- Any sharp edges may cause personal injury.

Never put fingers or other objects into the dispenser hole and ice chute. It may cause personal injury or material damage

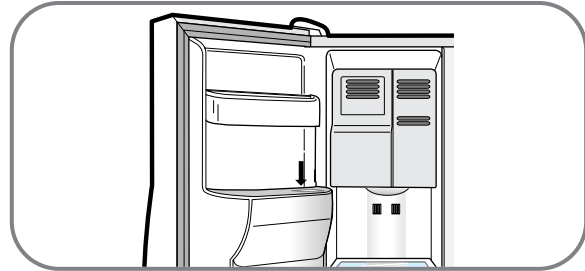

Do not use a wet or damp cloth when cleaning the plug. Remove any foreign matter or dust from the power plug pins.

- Otherwise there is a risk of fire.
- If the refrigerator is disconnected from the power supply, you should wait for at least five minutes before plugging it back.



If the refrigerator is not to be used for a long period of time, pull out the power plug.

- Deterioration in the insulation may cause fire.

- Contains fluorinated greenhouse gases covered by the Kyoto Protocol.

- Hermetically sealed system.

- Do not vent gases into the atmosphere.

- Refrigerant type: R-134a

- Quantity: 0.22 Kg

- Global Warming Potential (GWP) = 1300

SETTING UP THE REFRIGERATOR

Once you have performed the following steps, your refrigerator should be fully operational. If not, check the power supply and electricity source. If you have any questions, contact your SAMSUNG service center.

1 Place the refrigerator in an appropriate location with reasonable clearance between the wall and the refrigerator.
(refer to installation instructions in this manual)

3 Set the temperature control to the coldest temperature and wait for an hour. The freezer should get slightly chilled and the motor should run smoothly.

2 When the refrigerator is plugged in, the interior light should come on when you open the doors.

4 Once the refrigerator temperature is sufficiently low, you can store food in the refrigerator. After starting the refrigerator, it takes a few hours to reach the appropriate temperature.

MAJOR FEATURES

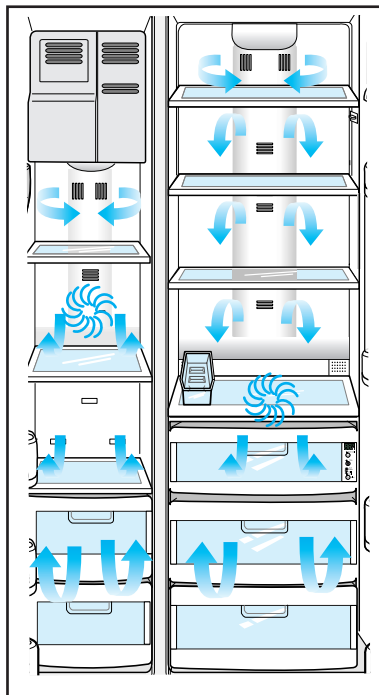

Twin Cooling System

- The refrigerator and the freezer have two evaporators. Given this independent system, the refrigerator and the freezer are cooled individually as required and are, therefore, more efficient. Food odor from the refrigerator does not affect food in the freezer due to separate air flow circulation.

Multi-Flow System

- Cool air circulates through multiple vents on every shelf level. This provides even distribution of cooling inside cabinets to keep your food fresh longer.

Xtra Space™

- Vertical room next to the ice maker in the freezer provides space for pizza etc.

Door Alarm

- A beeper reminds you if the door is left open.

Xtra Fresh™

- Optimized humidity control keeps vegetables & fruits fresh.

Deodorizer (optional)

- Reusable deodorizer keeps the refrigerator air fresh and odor free.

CoolSelect Zone™ Drawer(optional)

- User can select Quick Cool, Thaw and Select buttons for quickly chill, thaw and cools items. Select Soft Freeze, Cool or Chill to control the temperature of drawer.



This operation instruction covers various models.

The characteristics of your appliance may differ slightly from those described in this manual.

CONTROL PANEL

Basic Model

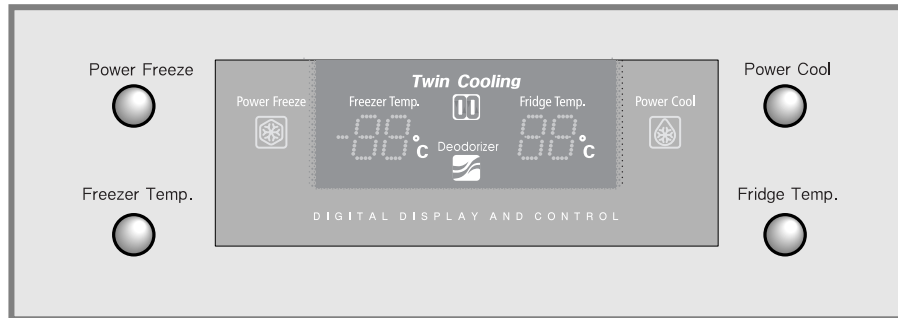

Dispenser Model (Child Lock)

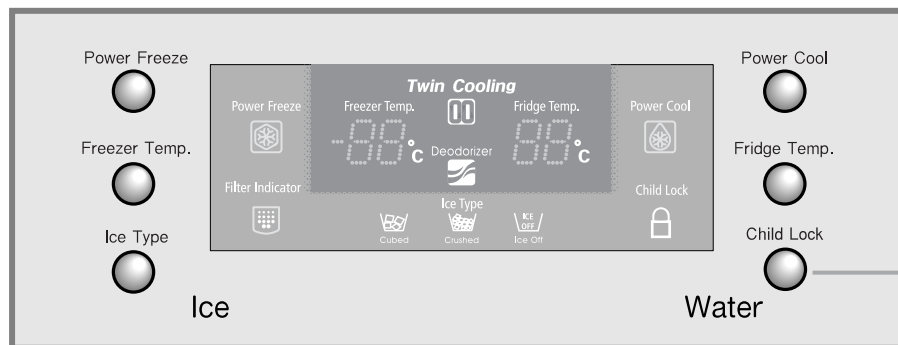

Dispenser Model (Moisture Control)

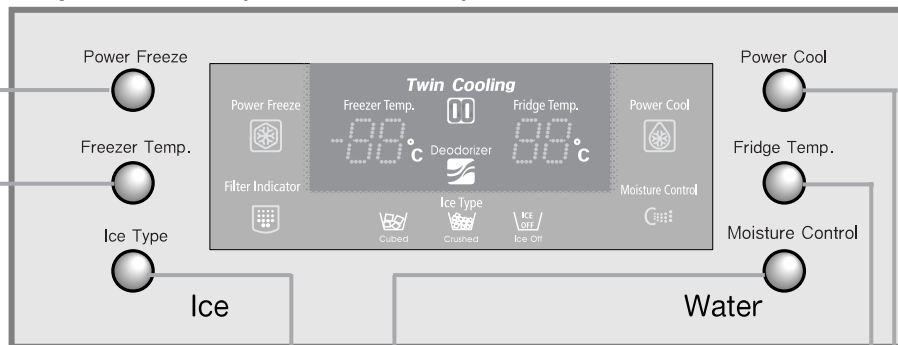

FREEZER TEMP. BUTTON

To set the freezer temperature, press the button repeatedly to change the set temperature in sequence between -14°C and -25°C

POWER FREEZE BUTTON

Speeds up the freezing process in the freezer.

ICE TYPE BUTTON

Use this button to choose Cubed or Crushed Ice or Ice off.

FRIDGE TEMP. BUTTON

To set the fridge temperature, press the button repeatedly to change the set temperature in sequence between 7°C and 1°C.

POWER COOL BUTTON

Speeds up the cooling process in the refrigerator

MOISTURE CONTROL BUTTON

Initially the light of moisture control button is on. If the moisture in the dispenser or Beverage Station™ is found, press this button. So the light will be on, and eliminate the moisture.

CHILD LOCK BUTTON

When this button is pressed for 3 sec., the Power Freeze, Power Cool, Freeze Temp. Fridge Temp. are locked and can not be modified. The Water and Ice dispenser are not locked as to allow for usage.

CONTROL PANEL

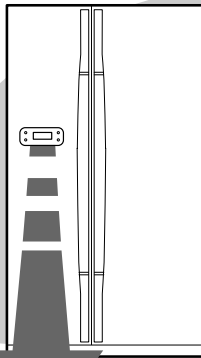

Basic Model (With CoolSelect Zone™)

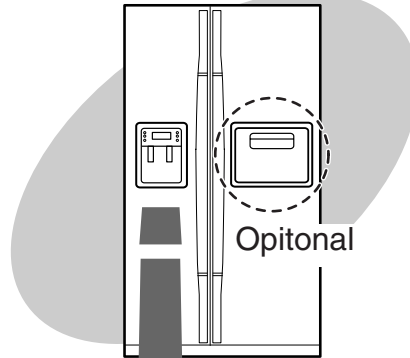
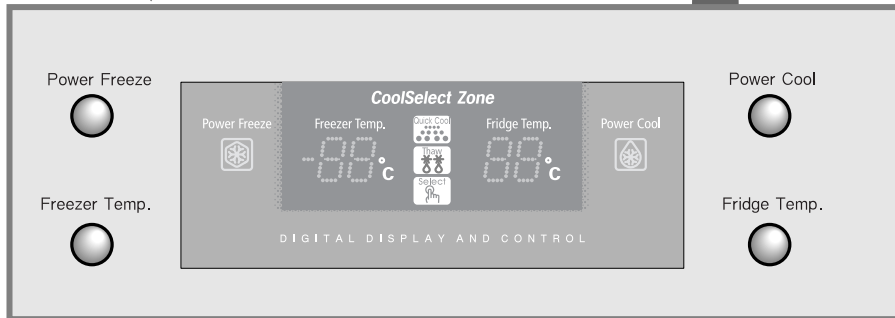

Optional

Dispenser Model (With CoolSelect Zone™)

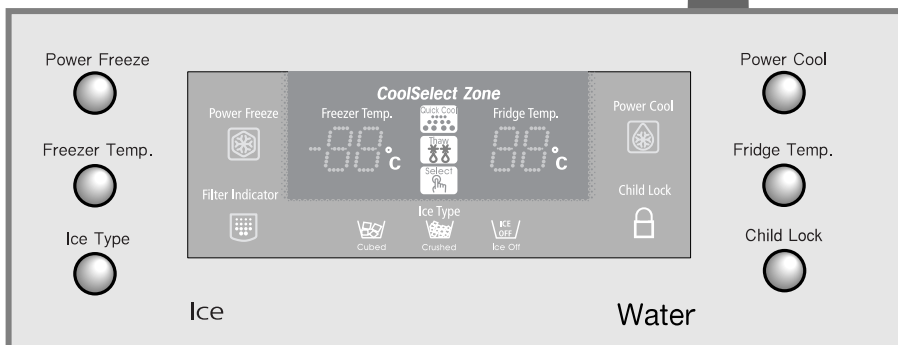

Dispenser Model (With CoolSelect Zone™)

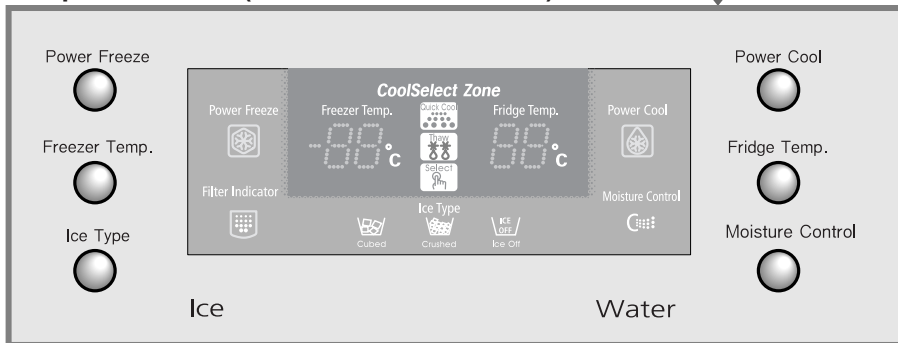

DIGITAL PANEL

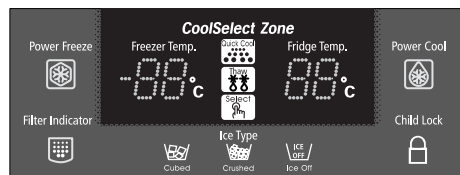
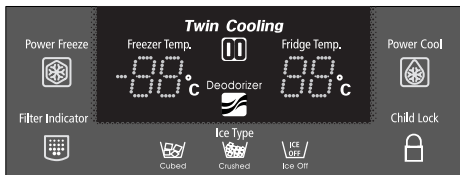
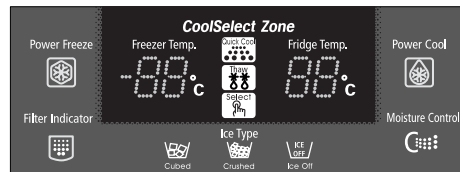
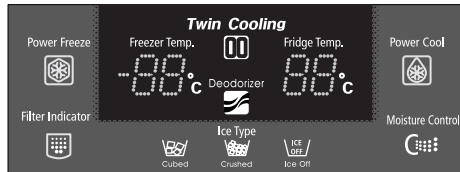
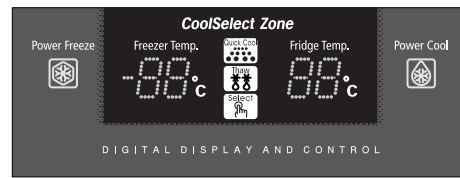
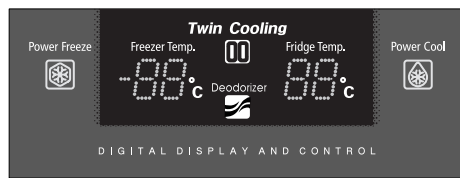

Freezer Temp. indicates the current freezer temperature.
Fridge Temp. indicates the current refrigerator temperature.
Quick Cool, Thaw, and Select show the status of the CoolSelect Zone™ Drawer



- This light is on when you press the Power Freeze button. Press this button to quickly return the freezer to the set temperature.
- If you need much ice, you can get ice faster.
- Press the button again to cancel the Power Freezer mode.



- This light is on when you press the Power Cool button. Press the button to quickly return the refrigerator to the set temperature.
- Press the button again to cancel the Power Cool mode.



- This light indicates the recyclable deodorizer is in operation.
- Recycle the honeycomb cartridge once or twice a year (see “Cleaning the Accessories” section)

Cubed Ice, Crushed Ice and Ice Off

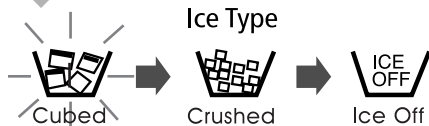

- Press the Ice Type button in sequence to choose Cubed Ice, Crushed Ice or Ice Off to stop making ice.
- Bright icon indicates the ice state currently operated.



- When the green light changes to orange, it is time to replace the water filter. If indicator is red, quick replacement is strongly recommended.
- When the water filter is replaced, reset the indicator by pressing the Ice Type button and the Child Lock buttons simultaneously for 3 seconds.
- To turn this indicator off, press the Ice Type and Child Lock buttons simultaneously for 5 seconds.

TEMPERATURE CONTROL

Freezer

- The freezer temperature can be set between -14°C and -25°C.
- Press the **Freezer Temp.** button **repeatedly** until the desired set temperature is shown in the temperature display.
- The temperature display changes in sequence between -14°C and -25°C. When the display reaches 14°C, it returns to -25°C.
- After five seconds, the display reverts to the actual freezer temperature. The unit will then work to adjust to the new desired temperature.

Refrigerator

- The refrigerator temperature can be set between 7°C and 1°C.
- Press the **Fridge Temp.** button repeatedly until the desired temperature is shown in the temperature display.
- The temperature display changes in sequence and reverts in the same way as the freezer.



WARNING

- When ice cream is stored above -15°C in freezer, it may melt.
- The temperature of the freezer or the refrigerator rises from frequent openings, when sweeping and from warm food. This may cause the digital display to blink. The digital display will stop blinking when the freezer and refrigerator return to the normal temperature.

ICE and COLD WATER DISPENSER

Ice Maker (Basic Model)





- Pull out the ice tray.
- Add water until it reaches the water level indicator.
- Put the ice tray back in place.

Ice Dispenser

The ice maker produces 10 cubes at once and about 120 cubes a day automatically. This quantity may be influenced by factors such as the freezer temperature, the Power Freeze function and the number of door openings. When your refrigerator is plugged in, the Cubed Ice mode is automatically selected.

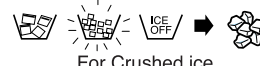
Press the Ice Type button to select the type of ice:

- Cubed Ice  For Cubed ice
- Crushed Ice  For Crushed ice
- No Ice  For ice off

NOTE  If the Ice remains in the Ice bucket, the cubed ice is obtained.

Push the ice dispenser lever with a cup.

- Place a cup in line with the dispenser lever the dispenser to prevent ice from jumping out.

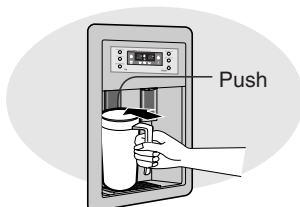

Water Dispenser

The capacity of the water tank is approximately 1.2ℓ.

Cold Water

- Push the water dispenser lever with a cup.
- If you have just installed the refrigerator, throw away the first six glassfuls of water to flush out impurities in the water supply system.



CAUTION

If you have a long vacation or business trip and won't use the water or ice dispensers, close the water valve. Otherwise, water may occur leakage.



WARNING

Never put fingers or any other objects in the dispenser opening. It may cause injury.

SHELVES AND BINS

Freezer

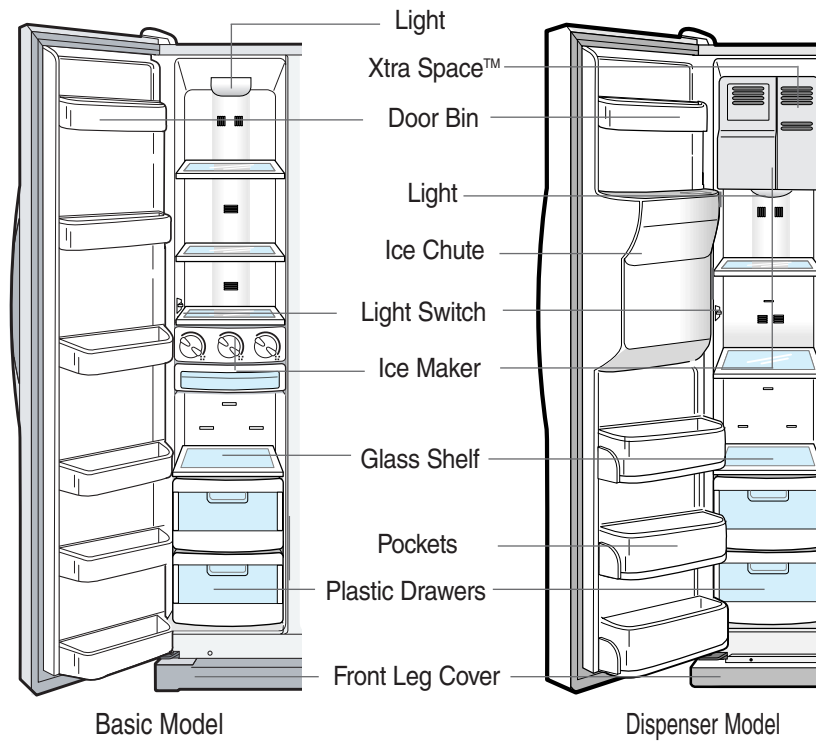

OPERATING INSTRUCTIONS

Refrigerator

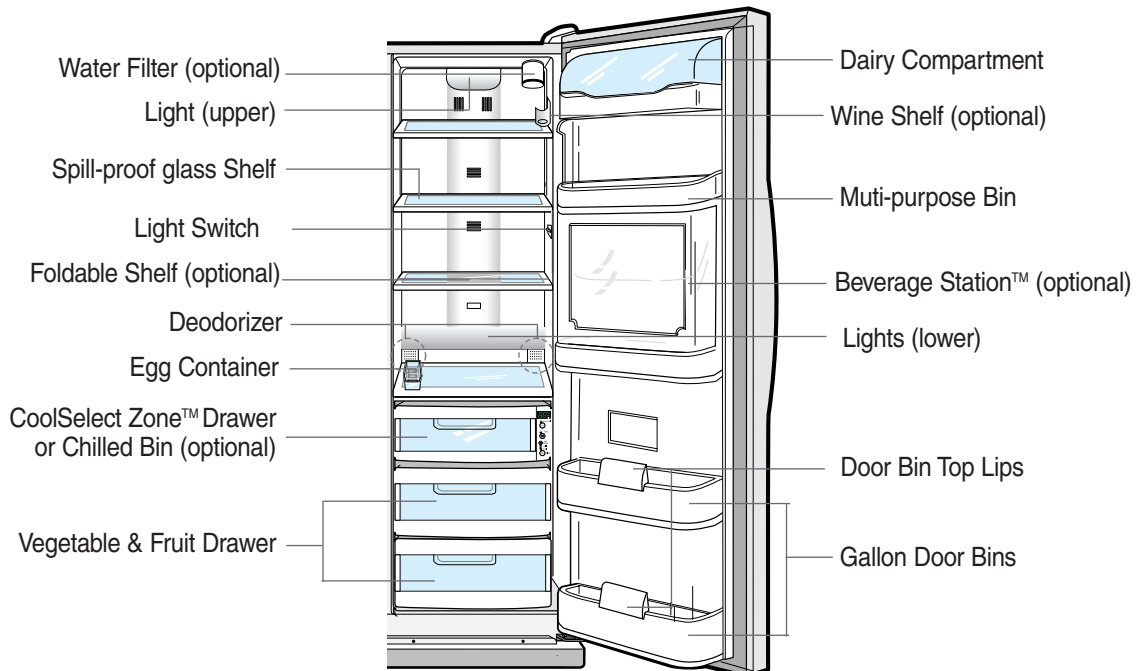

FOOD STORAGE GUIDE

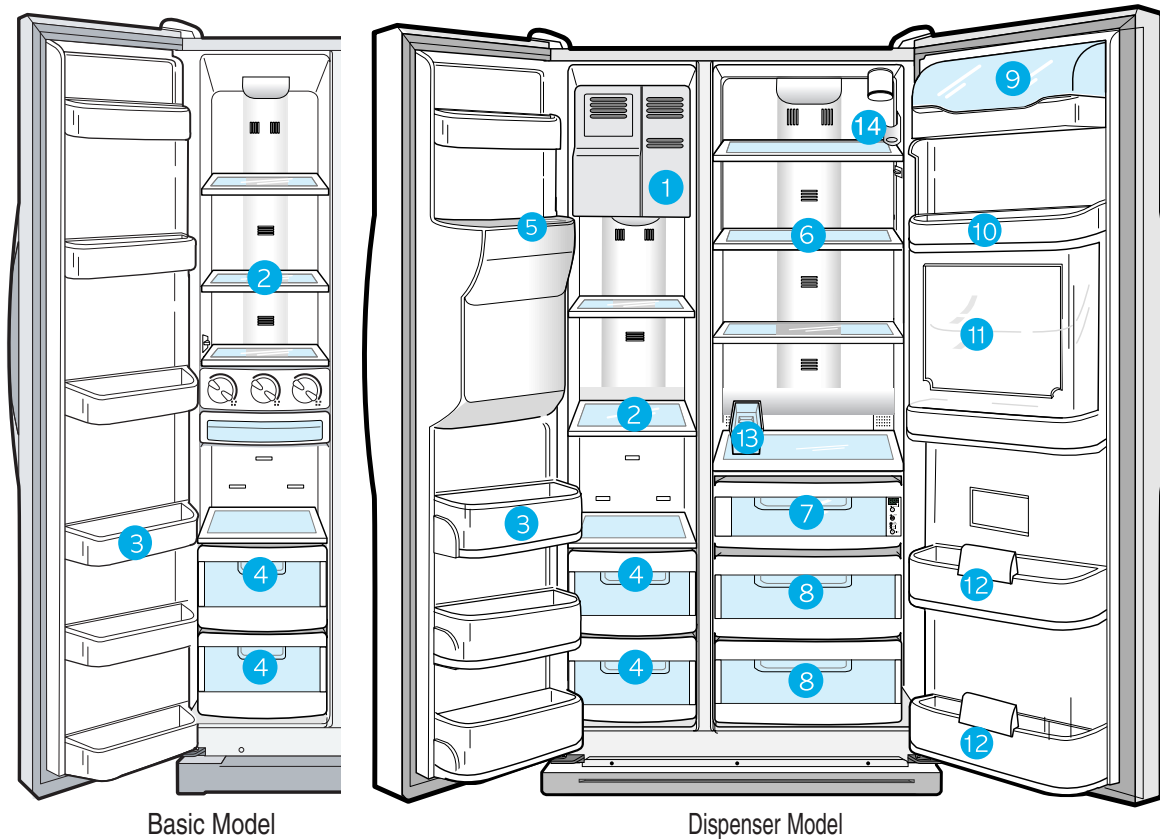

Basic Model

Dispenser Model

FROZEN FOOD STORAGE IN FREEZER

1

Xtra Space™

- Can be used for frozen foods such as pizza, pasta, burritos, and fajitas.
- In order to prevent odor penetration to the ice, stored food should be wrapped securely.

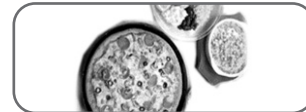

2

Tempered Glass Shelf

- Can be used to store all types of frozen food.

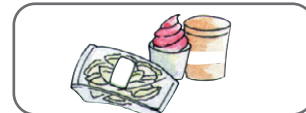

3

Door Bin

- Can be used for small packages of frozen food.

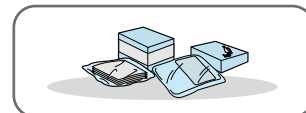

4

Plastics Drawer

- Can be used to store meat and dry foods. Stored food should be wrapped securely using foil or other suitable wrapping materials or containers.

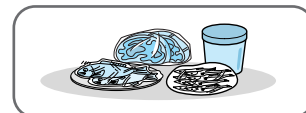

5

Ice chute



Do not put your fingers, hands or any other in suitable objects in the chute or ice-maker bucket. as this may result in personal injury or material damage.

FOOD STORAGE GUIDE

CHILLED FOOD STORAGE IN REFRIGERATOR

6 Tempered Spill Proof Glass Shelf

- Can be used to store all types of chilled food.
- Safe and hard to break resistant.
- Circular marks on the glass surface are a normal phenomenon.



7 Chilled Bin or CoolSelect Zone™ Drawer (optional)

- Helps to preserve the taste of food and prolongs its freshness. Use to store cheese, meat, poultry, fish or any other foods used quickly.

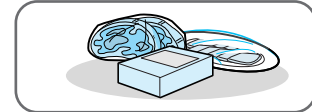

8 Fruit & Vegetable Drawer (Upper and Lower)

- Is used to store fruits and vegetables.
- This drawer is airtight. Optimized humidity control design helps to preserve the freshness of the stored vegetables and fruits.



NOTE

Without drawers, the fruit & vegetable can be stored.



9 Dairy Compartment

- Can be used to store butter or margarine.



10 12 Gallon Door Bins

- Can be used to store foods in small packages, such as milk and yogurt.



11 Beverage Station (optional)

- Can be used to store the frequently used items, such as canned beverages and snacks and allows access to these items without opening the refrigerator door.

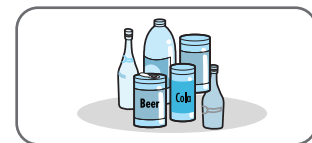

CAUTION

Bottles should be stored tightly together so that they do not fall out.

13 Egg Container

- Put eggs in the container and place them on the shelf.

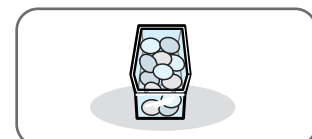

14 Wine Shelf (optional)

- Place your wine bottle on the shelf to maintain their taste.

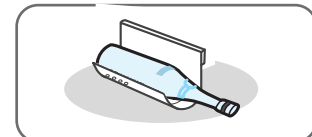

WARNING

- If you have a long vacation planned, you must decide to empty the refrigerator and turn it off. Wipe excess moisture from the inside and leave the doors open. Otherwise, odor and mold may develop.

CoolSelect Zone™ Drawer GUIDE

“Select” button (Optional)

1 Soft Freeze

- When “Soft Freeze” is chosen, the temperature on the digital panel displays -5°C regardless of the set temperature of the refrigerator.
- “Soft-Freeze” temperature helps keep meats and fishes fresh longer.
- Can cut meat easily without drips.

2 Chill

- When “Chill” is chosen, the temperature of the CoolSelect Zone™ Drawer is kept at -1°C regardless of the set refrigerator temperature.
- “Chill” temperature helps keep meat or fish fresh longer.

3 Cool

- When “Cool” is chosen, the temperature will be the same as the set temperature of the refrigerator. The digital panel shows the same temperature as that of the display panel.
- The CoolSelect Zone™ Drawer allows extra refrigerator space.

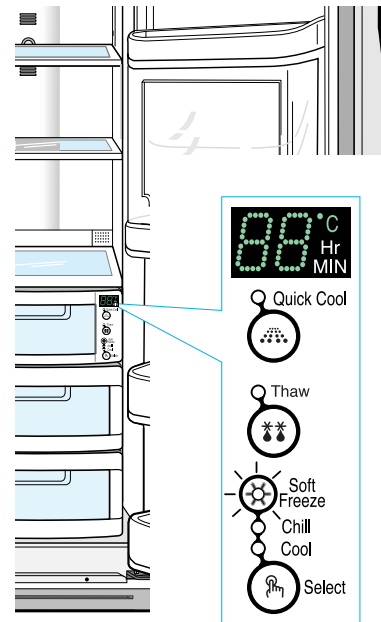

CoolSelect Zone™ Drawer GUIDE

“Quick Cool” button

- You can use the Quick Cool feature with the CoolSelect Zone™.
- “Quick Cool” allows 1~3 canned beverages to cool within 60 min.
- To cancel this option, press the “Quick Cool” button again. CoolSelect Zone™ returns to the previous temperature.
- When “Quick Cool” ends, it returns to the “Cool” temperature setting.



Depending on the beverages, the cool-down time may vary.



WARNING

- For “Quick Cool” option, food stored in the CoolSelect Zone™ Drawer should be removed.

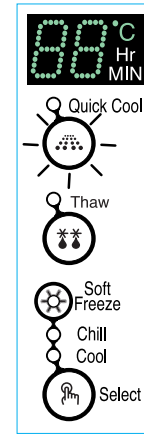

“Thaw” button

- Drips loss and quality deterioration of meats reduces the freshness of foods.
- After “Thaw” is selected, warm and cold air is alternately supplied into the CoolSelect Zone™ Drawer.
- Depending on the weight of meat, thawing time can be selected for 4 hrs, 6 hrs, 10 hrs, and 12 hrs sequentially.
- When “Thaw” ends, CoolSelect Zone™ display returns to “chill” condition.
- When “Thaw” ends, there are no juice in the meats and they are half-frozen condition so it is easy to cut them for cooking.
- To cancel this option, press any button except “Thaw”.
- The approximate thawing time of meat and fish are shown below. (Based on 1inch thickness)

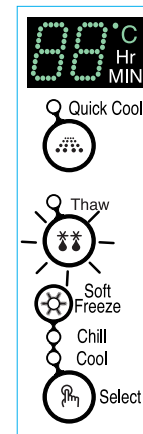

Thaw Time	4 hours	6 hours	10 hours	12 hours
Weight	400 g	600 g	800 g	1000 g



Depending on the size and thickness of meat and fish, the thawing time may vary.
 The above weight represents the total weight of food in the CoolSelect Zone™ Drawer.
 Ex) The total thawing time for 400g frozen beef and 600g frozen chicken will be 10 hours.



WARNING

- With the “Thaw” option, food stored in the CoolSelect Zone™ Drawer should be removed.

REMOVING THE FREEZER ACCESSORIES

1

Glass shelf

- Pull the shelf out as far as it goes. Then lift it up and remove it.

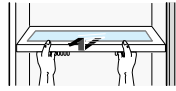

2

Door bin

- Hold the door bin with both hands and then lift it up.

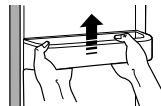

Plastic drawer

3

- Remove the drawer by pulling it out and lifting it up slightly.



4

Ice maker bucket (optional)

- Remove the bucket by lifting up and pulling out.

5

Front leg cover

- Open the freezer and refrigerator doors, remove three screws and detach the cover.
- To reassemble the cover leg front, put it back to original position and tighten the three screws.



NOTE

- Do not use excessive force when disassembling the cover. It may cause an injury.

REMOVING THE REFRIGERATOR ACCESSORIES

1

Spill Proof glass shelf

- Pull the shelf out as far as it will go. Then lift it up and remove it softly.

2

Fruit & Vegetable Drawer

- Remove the drawer by holding the handle, pulling the drawer out and lifting it up smoothly.
- Remove the optimized humidity control cover by pulling it towards you.

3

Gallon Door Bin

- Hold the bin with both hands and remove it by lifting it up.

4

Wine Shelf (optional)

- It is attached to the cabinet wall. To remove wine shelf, slide the wine shelf in the direction of the arrow as shown.
- Simply take the shelf out of the tabs.

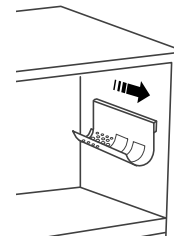

WARNING

- Before removing the freezer and refrigerator accessories, please move the stored foods to other space.

BEVERAGE STATION™ (optional)

To open the Beverage Station™, hold the Beverage Station™ door handle and pull it downward.

- The Beverage Station™ is convenient and reduces energy consumption, because you do not need to open the refrigerator door to access stored beverages and snacks.

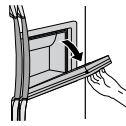

- It is recommended that you use the Beverage Station™ for storing most frequently needed foods



WARNING

- The door of the Beverage Station™ should never be removed. The Beverage Station™ cannot function if its door is missing.
- When closing the Beverage Station™ door, be careful not to put your hands or fingers around the door frame where they can be caught or injured.
- When you use the open door as a tray, do not place heavy objects on it. Do not allow children to hang on the door because there is a risk of personal injury or material damage.
- When you open the beverage station™ door, be careful not to hit children head.

CLEANING THE ACCESSORIES

Interior

- Clean the accessories with a mild detergent, then wipe out with a dry cloth.
- After washing the accessories, make sure that they are dry before using them again.



Exterior

- Wipe the digital panel and display panel with a clean cloth.
- The doors and handles should be cleaned with a mild detergent and cloth. Dry them with a clean cloth.
- The exterior part of refrigerator should be polished once or twice a year.

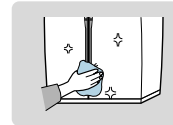

Rear

- Use a vacuum cleaner to remove dust once or twice a year.

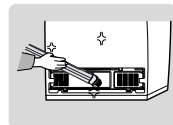

Ice and water dispenser (optional)

- Use a damp cloth to clean the ice and water dispenser. Then wipe it out with a dry cloth.
- To keep drainage grid dry, do not touch ice and water dispenser.



Beverage Station™ (optional)

- Use a damp cloth to clean the Beverage Station™. Then wipe it out with a dry cloth.



Rubber door seals

- If the rubber door seals are dirty, the door will not close properly, The refrigerator will not be able to function efficiently. Clean the doors with a mild detergent and damp cloth. Wipe with a dry cloth.



WARNING

- Do not spray the refrigerator with water. It may cause a death by an electric shock.
- Do not clean it with benzene, thinner or car detergent. It may cause a fire.

CLEANING THE ACCESSORIES

Deodorizer

- Remove the cover with a flat blade screw driver as shown.
- Take out the cartridge from the cover and soak it in clean, warm water at least than 4 hrs. Completely dry out the cartridge with sunlight for at least 8 hrs in an open area.
- Repeat this process once or twice a year.

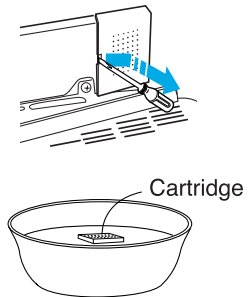

- If it is dried in a confined area, odor may be spread to that area.
- Keep the children away from yellow water, they may drink water.

CHANGING THE INTERIOR LIGHT



Before changing the interior light, unplug the refrigerator from the power supply. If you have difficulty in changing the light, contact your service center.



INTERIOR LIGHT IN THE REFRIGERATOR .

Upper

- 1** Pull out the screw cap ① and remove the screw.
- 2** Push the lamp cover in the direction of the arrows.
- 3** After changing the bulb, reattach the light cover and screw it in again.

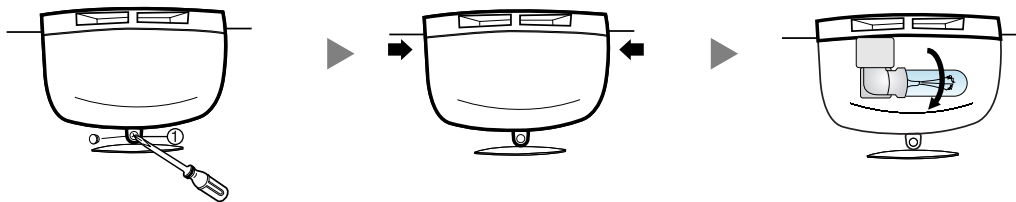

Lower (optional)

- 1** Pull out the screw cap ① and remove the screw.
- 2** Take the lamp cover out in the direction of the arrows.
- 3** After changing the bulb, reattach the light cover and screw it again.

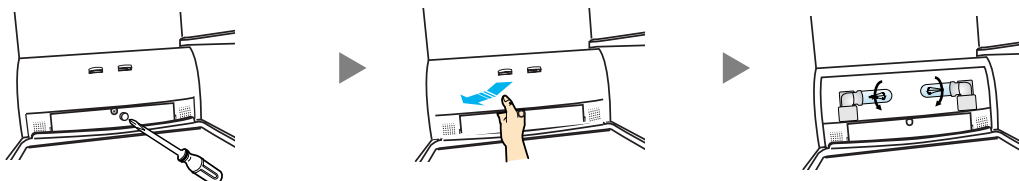

CHANGING THE INTERIOR LIGHT



INTERIOR LIGHT IN THE FREEZER (Dispenser Model)

- 1** Use a screwdriver to remove the light cover (①).

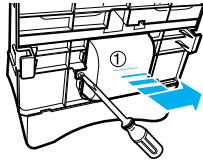

- 2** Change the bulb with a new one (②).

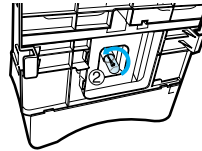

- 3** Reattach the light cover.

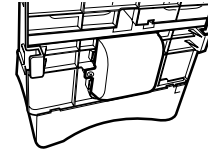

NOTE

To replace freezer and refrigerator light bulbs (Bulb size E14), please contact SAMSUNG dealer.



INTERIOR LIGHT IN THE FREEZER (Basic Model)

- 1** Pull out the screw cap (①) and remove the screw.

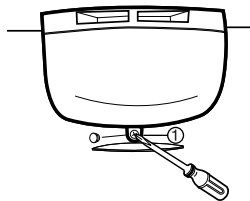

- 2** Push the lamp cover in the direction of the arrows.

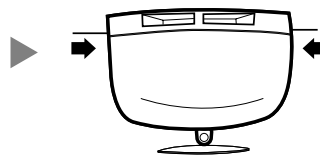

- 3** After changing the bulb, reattach the light cover and screw it in again.

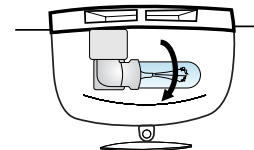

WATER FILTER

The water “Filter Indicator” light

- “Filter Indicator” light lets you know when it is time change your water filter cartridge. The light will change from green to orange. This tells you that it is almost time to change the current cartridge. It is recommended that you replace the cartridge when the light changes to red. (see “Install the water filter” section for more information)

Using the dispenser without the water filter

- You can not use the water and ice dispenser without a water filter cartridge because of the water line block at the water supply.

Ordering replacement filters

- To order more water filter cartridges, contact your authorized Samsung dealer.

DOORS

The refrigerator doors have a special door opening and closing feature to make sure that the doors close all the way and are securely sealed.

When opening the door, it will only open so far. After reaching a certain point, it will remain open.

When the door is partially open, it will close automatically .

INSTALLATION OF THE REFRIGERATOR



Checking the Dimensions of your Entrance Door



NOTE

- Check the dimensions of your entrance door to determine whether the refrigerator can pass through it.
- When refrigerator passes in door and depth or width of refrigerator is bigger, removes refrigerator doors.



Selecting the Location for the Refrigerator

- Select a location with easy access to the water supply.
- Select a location with enough space for the refrigerator.
- Select a location without direct exposure to sunlight.



Caution

- Before disassembling the freezer door, the water supply line needs to be disconnected. (If not, the water supply line can be damaged.)
- See “Separating the water supply line from the refrigerator” on the next page.

Allow sufficient space to install the refrigerator on a flat surface.

- If your refrigerator is not level, the internal cooling system may not work correctly.

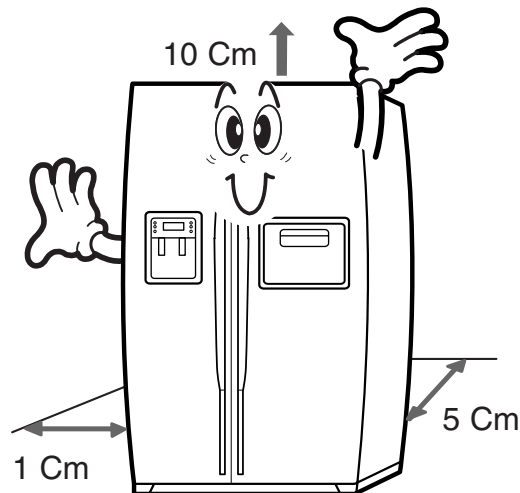

NOTE

Allow clearance to the right, left, back and top when installing the refrigerator. This has the advantage of reducing power consumption.

REMOVING THE REFRIGERATOR DOORS



Removing the Front Leg Cover (Optional)

Open the freezer and refrigerator doors, and then take off the front leg cover assembly by turning the three screws counter-clockwise.

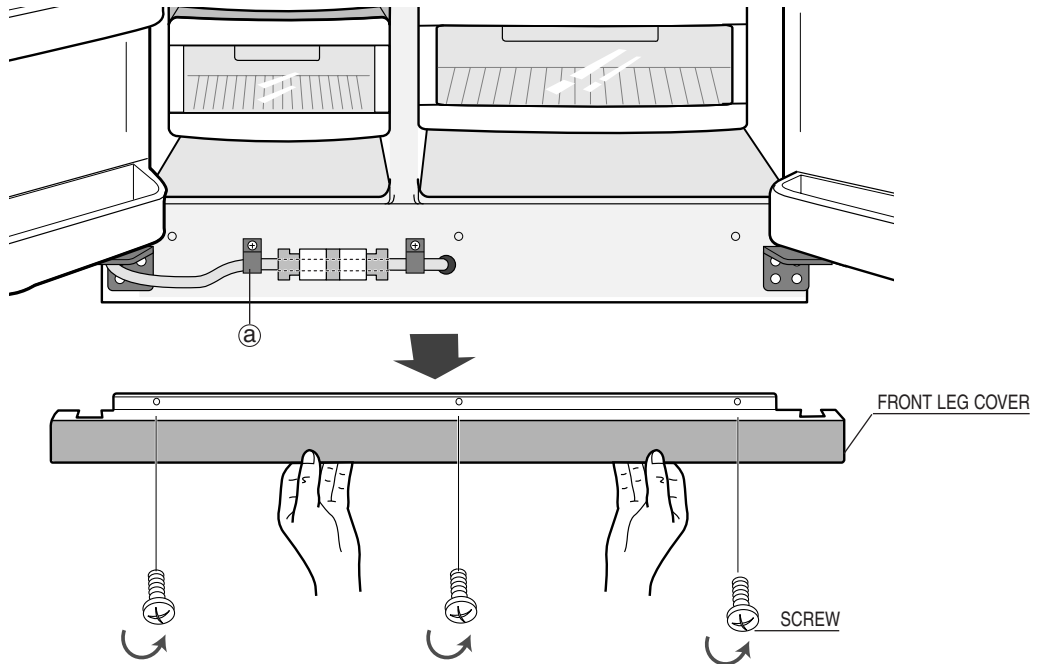

Separating the water supply line from the refrigerator (Optional)

- 1) Remove the screw from clamp (a).
- 2) Remove the water tube by pressing the coupler (2) and pulling the water tube (1) away.

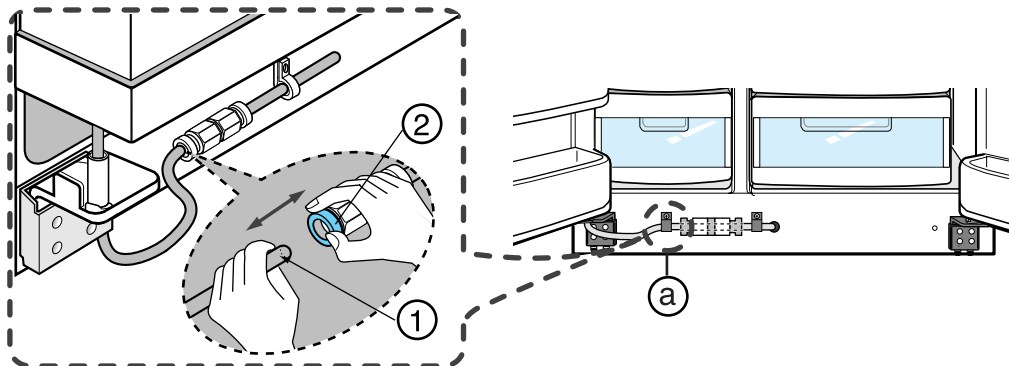

Do not cut the water tube but separate it from the coupler.

REMOVING THE REFRIGERATOR DOORS



- Lift the door straight up.
- Be careful not to pinch the water tubing and wire harness on the door.
- Place doors on a protected surface.



Removing the Freezer Door

- 1) With the door closed, remove the upper hinge cover (①) using a screwdriver, and then disconnect the wires (②).

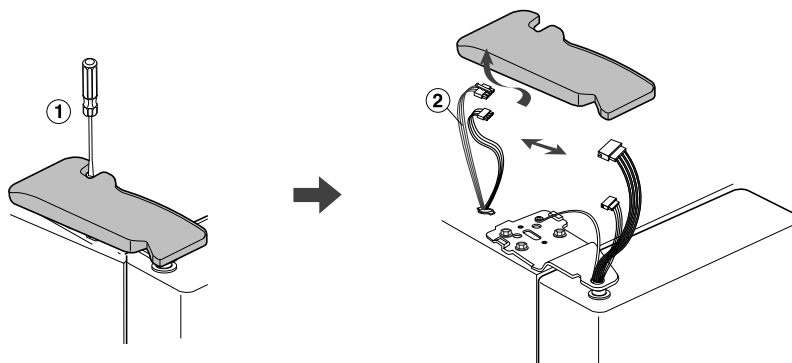

- 2) Remove hinge screws (③) and ground screw (④) counter-clockwise, and take off the upper hinge (⑤) along the arrow (⑥). Take care when removing the door to ensure that it does not fall on you.

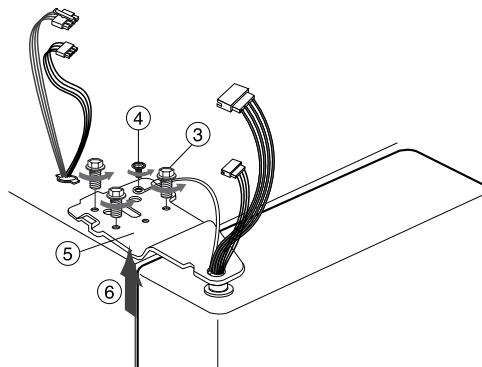

- 3) Remove the door from the lower hinge (⑦) by carefully lifting the door (⑧).

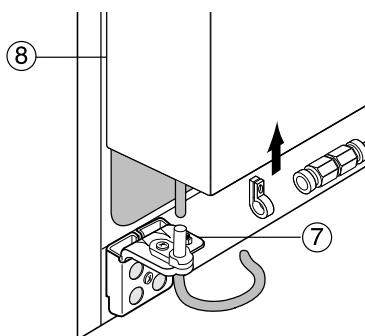

- 4) Remove the lower hinge (⑨) from the bracket lower hinge (⑩) by lifting the lower hinge (⑨) in the direction of the arrow.

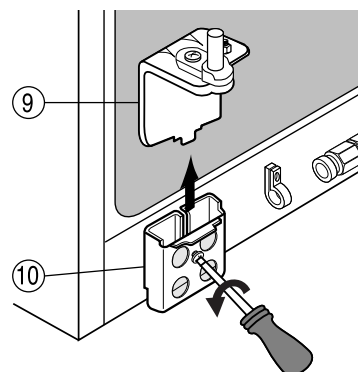

REMOVING THE REFRIGERATOR DOORS



Removing the Refrigerator Door

- 1) With the door closed, remove the upper hinge cover (①) using a screwdriver, and then disconnect the wires (②).

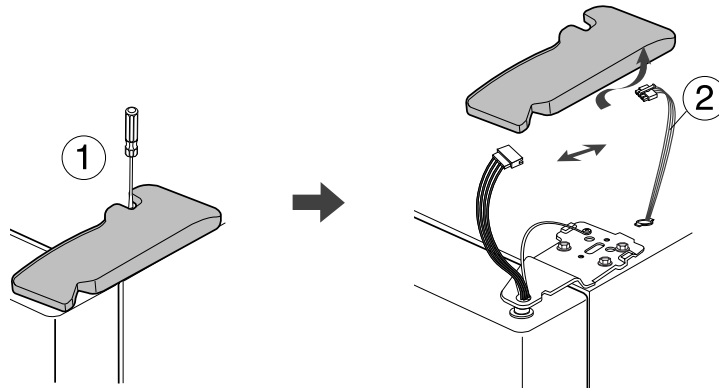

- 2) Remove hinge screws (③) and ground screw (④) counter-clockwise, and take off the upper hinge (⑤) in the direction of the arrow (⑥). Take care when removing the door to ensure that it does not fall on you.

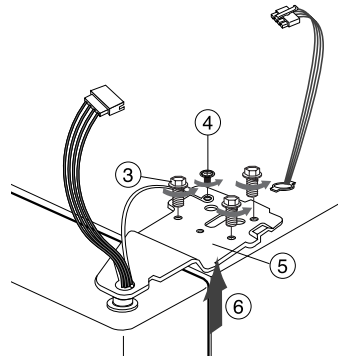

- 3) Remove the door from the lower hinge (⑦) by lifting the door (⑧).

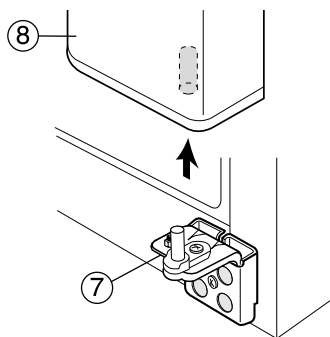

- 4) Remove the lower hinge (⑨) from the bracket lower hinge (⑩) by lifting the lower hinge (⑨) in the direction of the arrow.

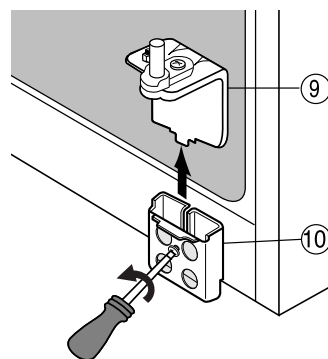

REATTACHING THE REFRIGERATOR DOORS



Reattaching the Freezer Door

1) Insert the lower hinge (①) in the bracket lower hinge (②).

2) Reattach the freezer door by inserting the hose (③) in the lower side of the door into the hole in the lower hinge (④) and pulling the hose down.

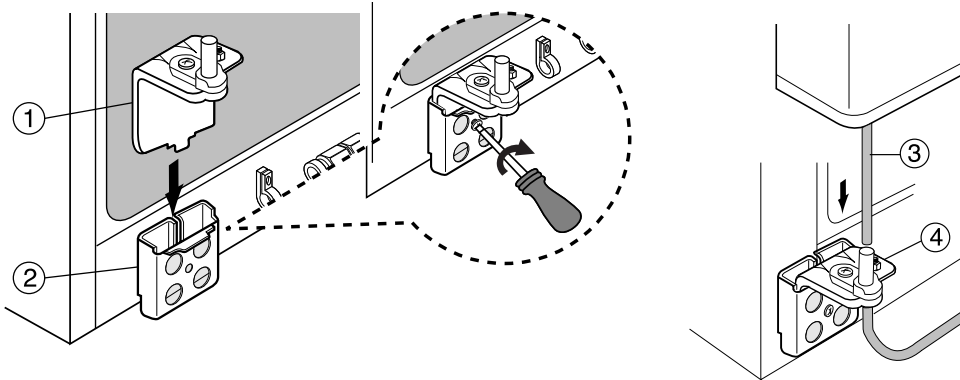

3) Insert the upper hinge shaft (⑤) into the hole (⑥). After levelling between the upper hinge hole (⑦) and the hole of the cabinet (⑧). Reattach bolts (⑨) and screw (⑩) in a clockwise direction.

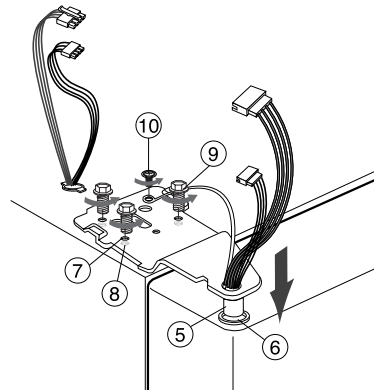

4) Connect the wires.

5) Put the front part of the upper hinge cover (⑪) on the front part of the upper hinge (⑫) and reattach from the front part of the upper hinge cover first.

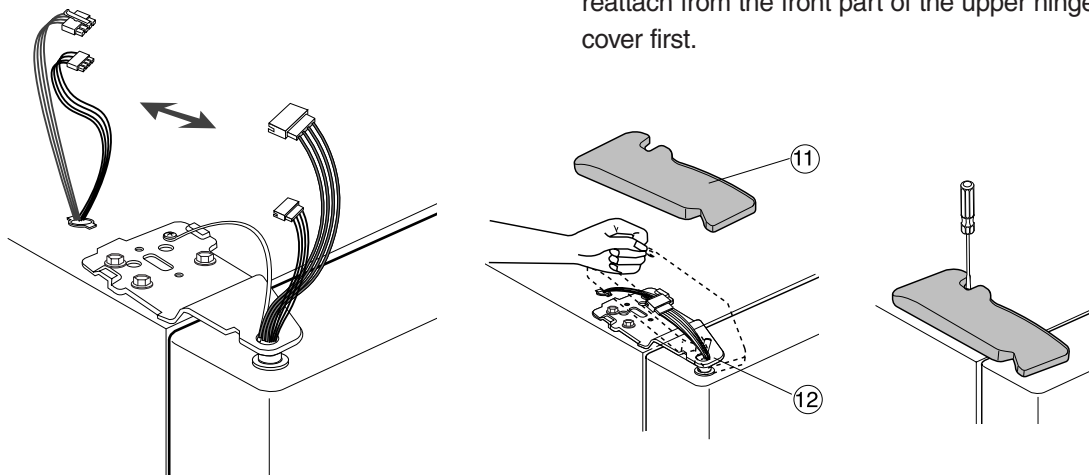

REATTACHING THE REFRIGERATOR DOORS



Reattaching the Refrigerator Door

1) Insert the lower hinge (①) in the bracket lower hinge (②).

2) Place the hole in the refrigerator door (③) over the lower hinge (④).

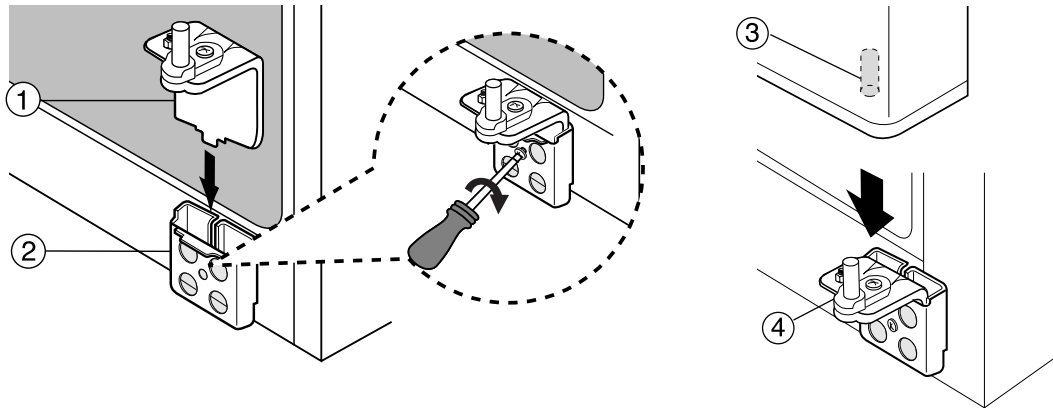

3) Insert the upper hinge shaft (⑤) into the hole (⑥). After levelling between the upper hinge hole (⑦) and the hole of the cabinet (⑧). Reattach hinge screws (⑨) and screw (⑩) in the clockwise direction.

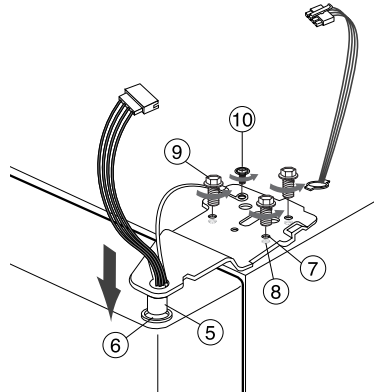

4) Connect the wires.

5) Put the front part of the upper hinge cover (⑪) on the front part of the upper hinge (⑫) and reattach it from the front part of the upper hinge cover first.

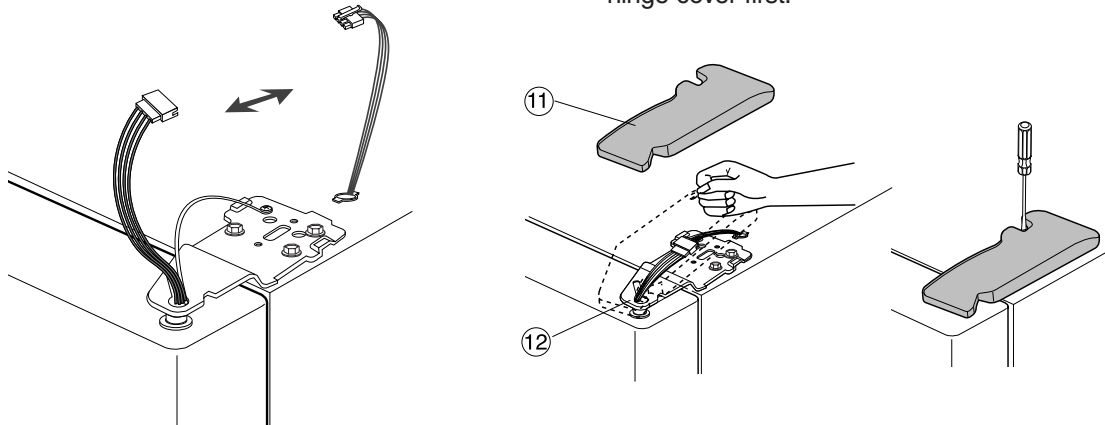

INSTALLATION INSTRUCTIONS

REATTACHING THE REFRIGERATOR DOORS



Reattaching the Water Tube (Optional)

- 1) While pressing the front face of coupler (②), insert the water line (①) in the coupler.
- 2) Tighten the screw on the clamp (a).

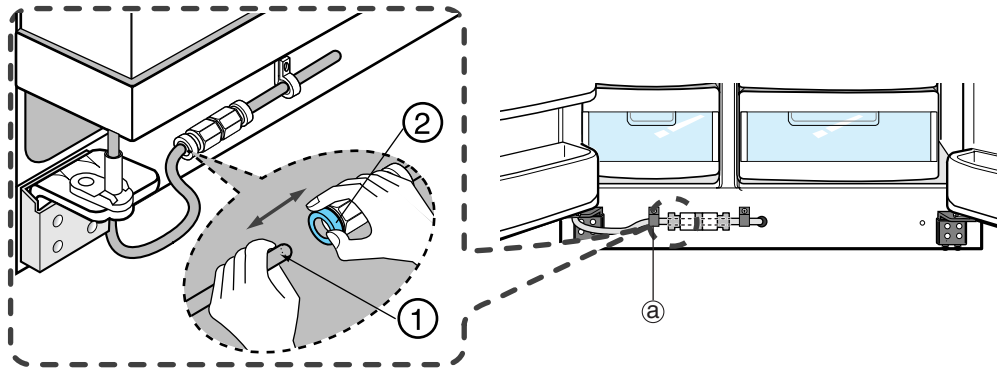

Reattaching the Front Leg Cover (Optional)

Put on the front leg cover by turning the three screws clockwise, as shown in the figure.

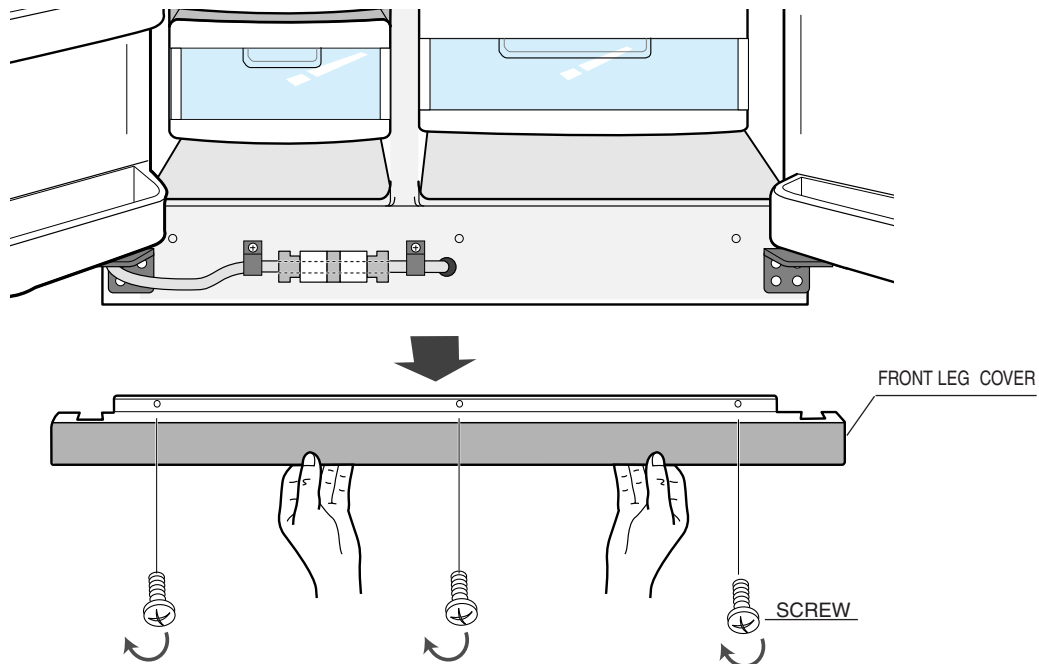

ADJUSTING THE CLEARANCE BETWEEN THE DOORS



Please level the refrigerator first.

The doors will be uneven if the refrigerator is not level.

Case 1) Freezer door is lower than that of the refrigerator

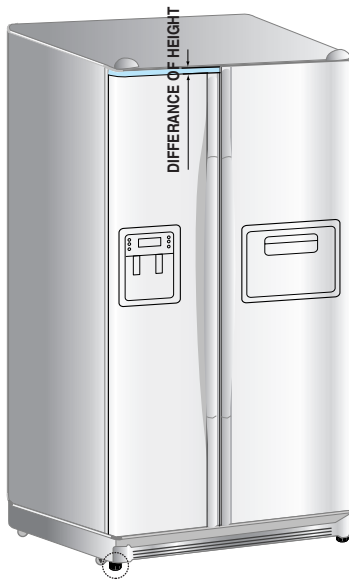

Insert a straight screwdriver (-) (①) into a slot of the control lever (②), turn it clockwise and level the refrigerator.

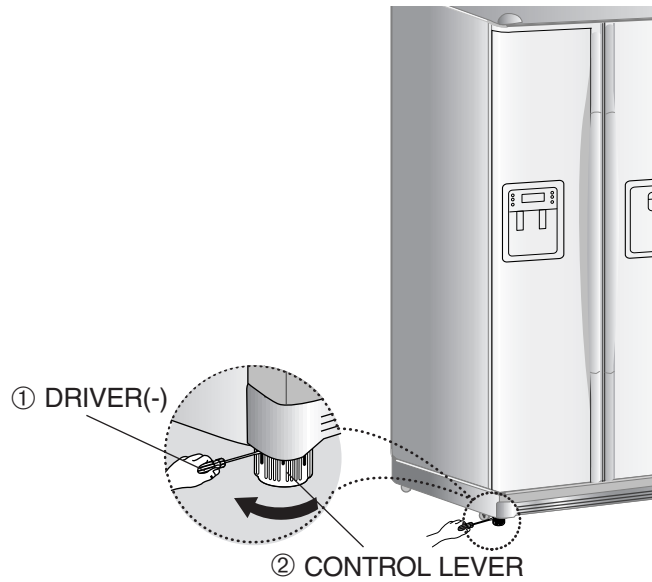

Case 2) Freezer door is higher than that of the refrigerator



Insert a straight screwdriver (-) (①) into a slot of the control lever (②), turn it clockwise and level the refrigerator.

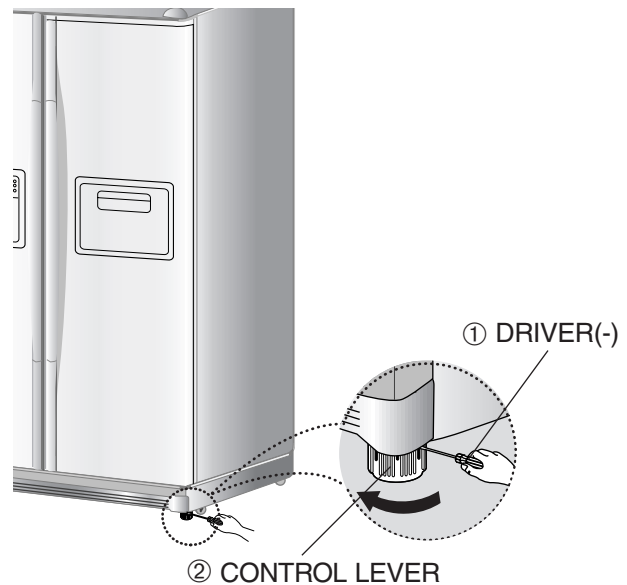

Do not make small adjustment by turning the control lever, Please refer to the next page.

ADJUST THE CLEARANCE BETWEEN THE DOORS



Making small adjustments between doors.

If the door of the freezer is lower than that of the refrigerator.



If the door of freezer is higher than that of the refrigerator.



Please open the doors and adjust the doors as follows:

- 1) Release the nut (①) on the lower hinge until the upper end of the bolt (②).



NOTE

When you release the nut (①), use enclosed hex wrench (③) to turn the bolt (②) a little counter clockwise to make the nut (①) loose with your fingers.



- 2) Please adjust the height difference between the doors turning the bolt (②) turn clockwise (↻) or counter clockwise (↺).



NOTE

When you turn clockwise (↻), the door goes up.

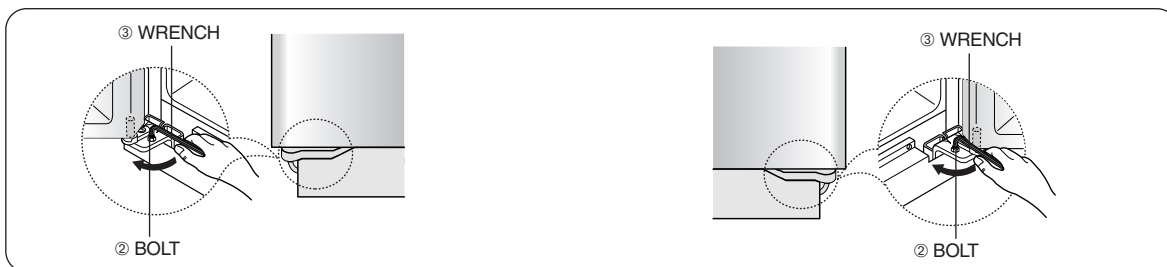

- 3) After adjusting the doors, turn the nut (①) turn clockwise (↻) until the lower end of the bolt, then tighten the bolt again with the wrench (③) to fix the nut (①).

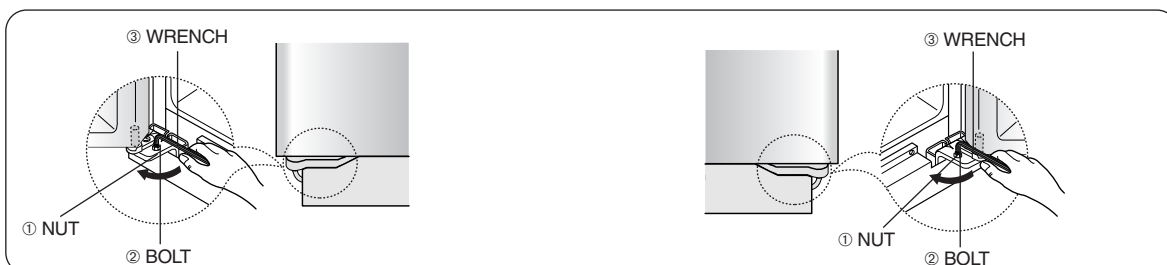

NOTE

If you do not fix the nut (①) firmly, the bolt (②) may be released.

CHECKING THE WATER DISPENSER LINE (Optional)

- 1) In order to operate the ice maker properly, water pressure of 1.4 ~ 10 kgf/cm² is required. In this range a 100 cc paper cup can be filled in 10 seconds.
- 2) The water filter removes particles. It does not sterilize or destroy any micro-organisms.
- 3) If the refrigerator is installed in an area with low water pressure (below 1.4kgf/cm²), you should install a booster pump to compensate for the low pressure.
- 4) Ensure the water storage tank inside the refrigerator is properly filled initially. Push the water dispenser lever until the water runs from the outlet.



A universal water supply kit is available at extra cost from your dealer. The refrigerator manufacturer recommends using a water supply kit containing copper tubing.



Checking the Parts

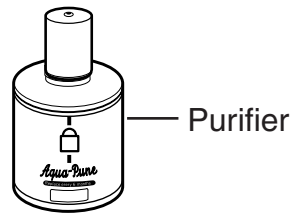

(Interior model)

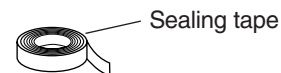

Sealing tape



Tapping screw x 12EA

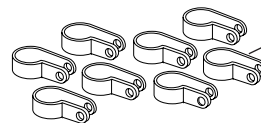

Clip A x 8EA

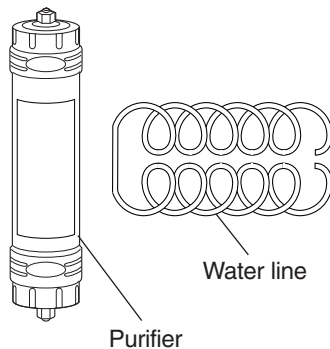

Purifier

Water line

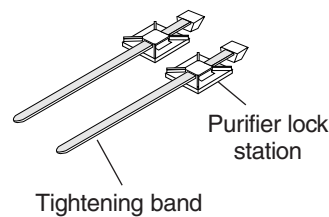

Tightening band

Purifier lock station

(Exterior model)

INSTALLING OF THE WATER DISPENSER LINE

For Interior Model (Case 1)



Connecting to water supply line

- Shut off the main water supply line and turn the Ice maker to the off position.
- Locate the nearest cold drinking water line.
- Follow the instructions in the ice maker installation kit.

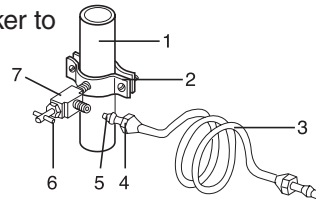

1. Cold Water line
2. Pipe Clamp.
3. Copper (or Plastic) line
4. Compression Nut
5. Compression Sleeve
6. Shut Off Valve
7. Packing Nut.



Connect the water line to the refrigerator

- Slip the compression nut and plastic ferrule through the plastic tube.
- After inserting the sleeve, tighten the compression nut onto 1/4" compression fitting(union).



NOTE Do not overtighten the compression nut.

- Slip the compression ferrule and nut on copper (or plastic) tubing as shown. Tighten the compression nut onto the compression fitting(union).
- Turn water on and check for any leakage.

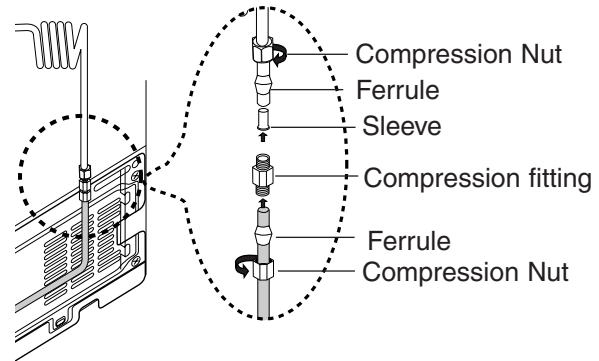

NOTE Waterline must be connected to drinkable water only

(Case 2)



Check the water supply line

- Connect the water pipe with coupler and tap.
- Close the main water tap.
- Connect coupler "A" to the tap.
- Every joint should be protected with sealing tape.

WARRANTY INFORMATION

This water line installation is not covered by the refrigerator or ice maker manufacturer's warranty. Follow these instructions carefully to minimise the risk of expensive water damage.

Note:

If the coupler does not fit on the current tap, go the nearest authorised service dealer and purchase the right couplers fittings.

CAUTION

The water line must be connected to the cold water pipe. If it is connected to the hot water pipe, it may cause the purifier to malfunction.

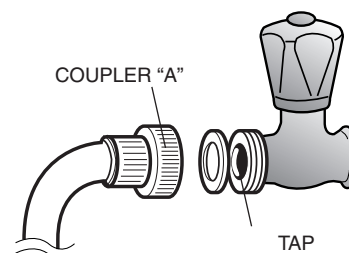

INSTALLING THE WATER DISPENSER LINE



Connect the water line to the refrigerator.

- Remove the compressor cover of the refrigerator.
- Connect the water line to the valve, as shown in the figure.
- When connected, check if there is any leakage. If any, repeat the connection.
- Reattach the compressor cover of the refrigerator.

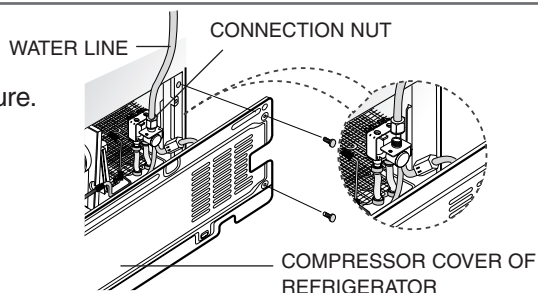

Secure the water line.

- Using clip "A", fix the water line to the wall or (the back of refrigerator).
- When the water line is secure, make sure whether the water line is not excessively bent, pinched or squashed.

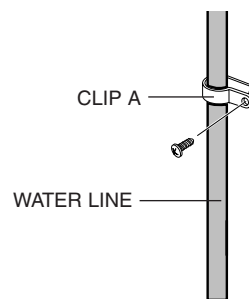

Complete the installation of the water supply line.

- Power on the refrigerator and press the lever on the right of the dispenser until water runs out through the water line and all air has been empty.
- At this time, check for any possible leakages at the join point in the water line. After securing the water line, move the refrigerator to the required location. Once the refrigerator is in position, do not move possibly.



Install the water filter.

- As shown, separate the fixed cap in the refrigerator by rotating it counterclockwise. Remove the water filter from the box and put a month indicator sticker on the filter as shown.
- Write the month you installed the filter on the label. EX) If the water filter was installed in March, put "MAR"
- Remove the protective cap then position and insert the filter as shown,
- Slowly turn the water filter clockwise 90° to align the indication mark on the cover, locking the filter in position. Do not overtighten.

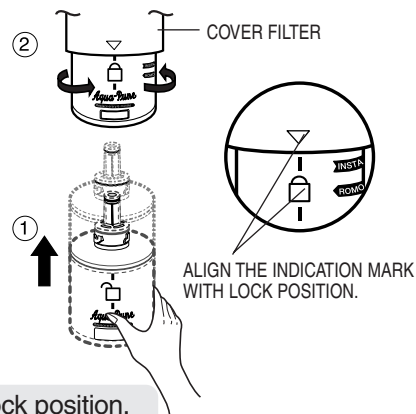
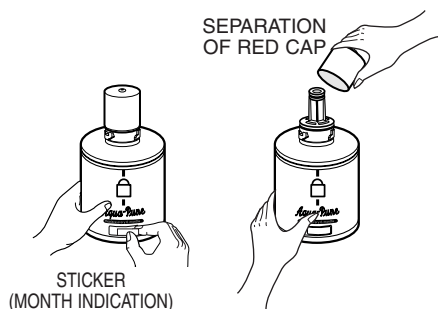
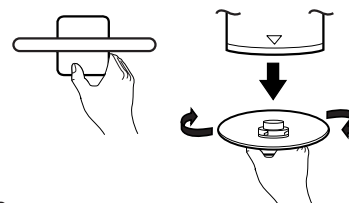

Caution

Please check if the indication line aligns with the lock position.

INSTALLING THE WATER DISPENSER LINE

For Exterior model



Connect to the water supply line

Connect the water pipe with coupler and tap.

- Close the main water tap.
- Connect coupler "A" to the tap.
- Every join should be protected with sealing tape.

CAUTION

The water line must be connected to the cold water pipe. If it is connected to the hot water pipe, it may cause the purifier to malfunction.

WARRANTY INFORMATION

This water line installation is not covered by the refrigerator or ice maker manufacturer's warranty. Follow these instructions carefully to minimise the risk of expensive water damage.

Note:

If the coupler does not fit on the current tap, go to the nearest authorised service dealer and purchase the right couplers fittings.

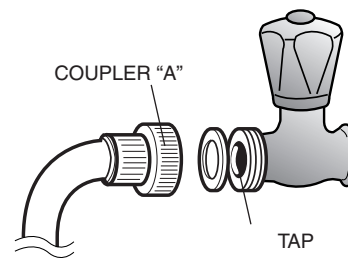

Select the location where the purifier is to install. (Model with the purifier)

- Cut the water line attached to the purifier to the appropriate place after measuring the distance between the purifier and the cold water tap.
- If you wish to reassemble the water inlet and outlet sides of the purifier during purifier installation, see the reference illustration.

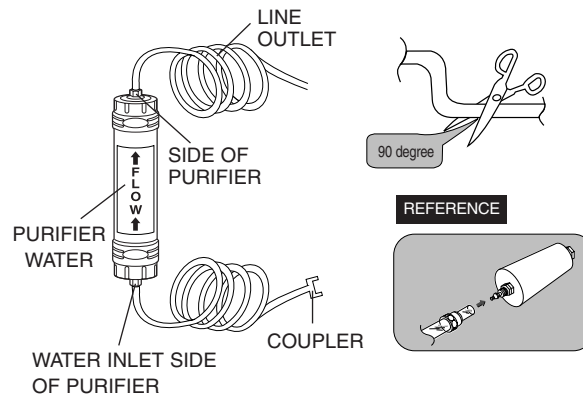

Remove any residual matter inside the purifier. (Model with the purifier)

- Open the main water tap to check whether water is running through the water tube on the water inlet side of the purifier.
- If water does not come out through the line, check whether the tap is open.
- Leave the tap open until clean water is running out and any residual matter that built up during manufacturing has been removed.

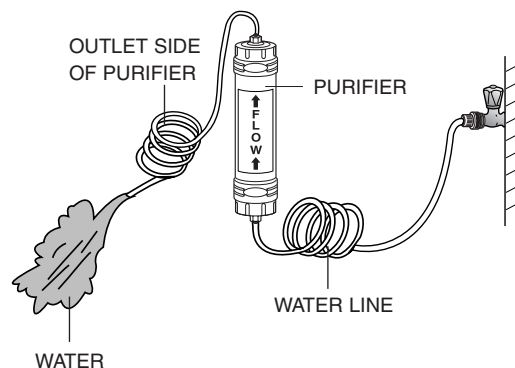

INSTALLING THE WATER DISPENSER LINE

Attach the purifier lock stations.

- Hold the purifier lock stations in the appropriate position (under the sink for example) and fix it tightly into place where to screw.

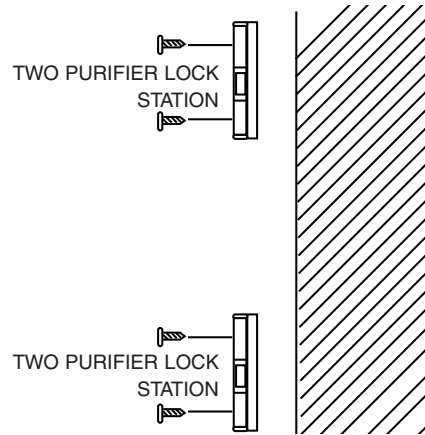

Secure the purifier in position.

- Fix the purifier in position, as shown in the figure on the right.

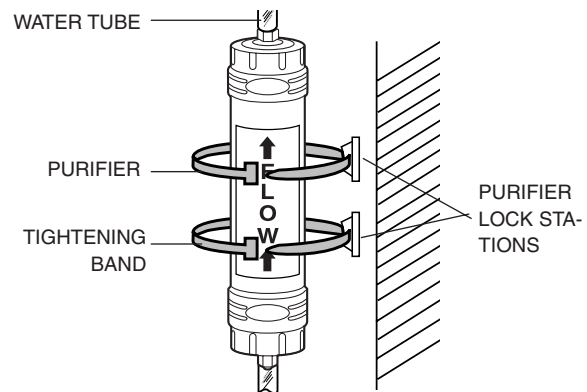

Connect the water line to the refrigerator.

- Remove the compressor cover of the refrigerator.
- Connect the water line to the valve, as shown in the figure.
- When connected, check if there is any leakage. If any, repeat the connection.
- Reattach the compressor cover of the refrigerator.

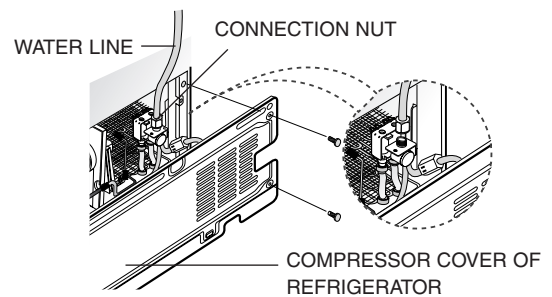

Secure the water line.

- Using clip "A", fix the water line to the wallor (the back of refrigerator).
- When the water line is secure, make sure whether the water line is not excessively bent, pinched or squashed.

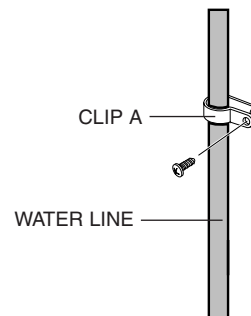

INSTALLING THE WATER DISPENSER LINE



Remove any residual matter inside the water supply line

- 1) Turn on the main water supply & shut-off valve of the water supply line.
- 2) Run water through the dispenser until the water runs clear (6~7 minutes). This will clean the water supply system and clear air from the lines.
- 3) Additional flushing may be required in some households.
- 4) Open the refrigerator door and check if water leaks around the water filter.

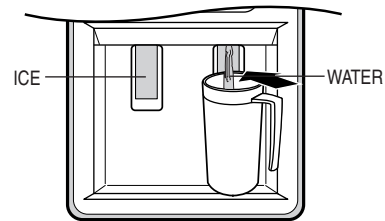

- A newly-installed water filter cartridge may cause water to briefly spurt from the dispenser.
- Before reinstalling the water filter, remove the wine shelf.



Check the amount of water supplied to the ice tray.

- 1) Lift up (①) and pull out (②) the ice maker bucket in the freezer.

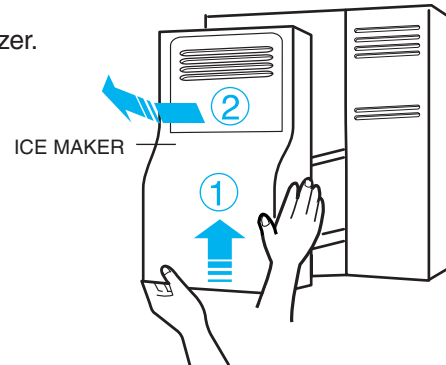

- 2) When you press the test button, the ice cube container is filled with water from the water supply tap. Check the amount of water (see the illustration below).

If the water level is too low, the ice cubes will be small.

This is not a problem with the ice maker but of the water pressure in the pipe, and occurs frequently.

When this problem occurs, contact the dealer service center to check the amount of water supplied.

CHECK THE WATER LEVEL

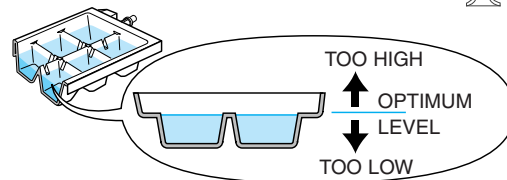
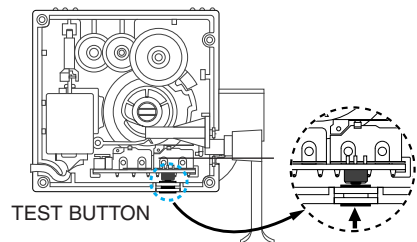
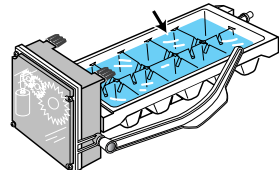

TROUBLESHOOTING

The refrigerator does not work at all or it does not chill sufficiently

- Check that the power plug is properly connected.
- Is the temperature control on the display panel set to the correct temperature? Try setting it to a lower temperature.
- Is the refrigerator in direct sunlight or located near a heat source?
- Is the back of the refrigerator too close to the wall?

The food in the refrigerator is frozen

- Is the temperature control on the display panel set to the correct temperature? Try setting it to a warmer temperature.
- Is the temperature in the room too low?
- Did you store the food with a high water content in the coldest part of the refrigerator.

You can hear unusual noise or sounds

- Check that the floor is levelled and stable.
- Is the back of the refrigerator too near to the wall?
- Was anything dropped behind or under the refrigerator?
- A “ticking” sound may be heard from inside the refrigerator, but this is normal. This occurs because various accessories are contracted or expanded.

The front corners and sides of the cabinet are hot; condensation occurs.

- Anti-condensators are installed in the front corners of the refrigerator to prevent condensation.
- Condensation can occur when you leave the door open for a long time.

Ice is not dispensed

- Did you stop the ice making function?
- Is there any ice in the ice storage unit?
- Is the water line connected and the shut-off valve open?
- Is the freezer temperature too warm? (Set the temperature lower)
- Did you wait for 12 hours after installation of the water supply line before making ice?

You can hear water bubbling in the refrigerator

- The bubbling comes from the refrigerant circulating in the refrigerator and is normal.

There is a bad smell in the refrigerator

- Wrap food with a strong smell so that it is airtight. Throw away any rotten food.

Frost forms on the wall of the freezer

- Is the air vent blocked?
- Allow sufficient space between the foods stored for efficient air circulation.
- Is the door closed properly?

No water is supplied

- Is the water line connected and the shut-off valve open?
- Is the water supply line crushed?
- Is the water tank frozen because the refrigerator temperature is too low? Select a warmer setting on the display panel.

MEMO

A large, empty rectangular box with rounded corners, intended for writing a memo. The box is white with a thin black border and occupies most of the page below the header.

MEMO

A large, empty rectangular box with rounded corners, intended for writing a memo. The box is white with a thin black border and occupies most of the page below the header.

Ambient Room Temperature Limits

This appliance is designed to operate at the ambient temperatures specified by its temperature class marked on the rating plate.

Temperature Class	Symbol	Ambient Temperature	
		Maximum	Minimum
Extended Temperate	SN	32°C (90°F)	10°C (50°F)
Temperate	N	32°C (90°F)	16°C (61°F)
Subtropical	ST	38°C (100°F)	18°C (64°F)
Tropical	T	43°C (109°F)	18°C (64°F)

NOTE : The internal temperature may be affected by such factors as the location of the appliance, ambient temperature and the frequency with which you open the doors.
Adjust the temperature as required to compensate for these factors.

English



Correct Disposal of This Product (Waste Electrical & Electronic Equipment)

(Applicable in the European Union and other European countries with separate collection systems)

This marking shown on the product or its literature, indicates that it should not be disposed with other household wastes at the end of its working life. To prevent possible harm to the environment or human health from uncontrolled waste disposal, please separate this from other types of wastes and recycle it responsibly to promote the sustainable reuse of material resources.

Household users should contact either the retailer where they purchased this product, or their local government office, for details of where and how they can take this item for environmentally safe recycling.

Business users should contact their supplier and check the terms and conditions of the purchase contract. This product should not be mixed with other commercial wastes for disposal.

Contact SAMSUNG WORLD WIDE

If you have any questions or comments relating to Samsung products, please contact the SAMSUNG customer care center.

COUNTRY	CALL	Web site
AUSTRALIA	1300 362 603	www.samsung.com
COLOMBIA	01-8000112112	www.samsung.com.co
EIRE	0818 717 100	www.samsung.com/ie
HONG KONG	3698-4698	www.samsung.com/hk
INDIA	3030 8282 , 1800 110011	www.samsung.com
MALAYSIA	1800-88-9999	www.samsung.com/my
NEW ZEALAND	0800SAMSUNG(726-7864)	www.samsung.com/nz
PANAMA	800-7267	www.samsung.com/latin
PHILIPPINES	1800-10-SAMSUNG(726-7864)	www.samsung.com/ph
SINGAPORE	1800-SAMSUNG(726-7864)	www.samsung.com
SOUTH AFRICA	0860-SAMSUNG(726-7864)	www.samsung.com
U.K	0845 SAMSUNG (7267864)	www.samsung.com
VIETNAM	1 800 588 889	www.samsung.com

- In an effort to promote recycling this user manual is printed on recycled paper.