



E.H. Wachs Company
100 Shepard Street
Wheeling, IL 60090
www.wachsco.com

WTP4800 Hydraulic Trash Pump

User's Manual



E.H. Wachs Company Part No. 08-MAN-04
Rev. 0-0506, May 2006

Revision History:
May 2006

Copyright © 2006 E.H. Wachs Company. All rights reserved.
This manual may not be reproduced in whole or in part
without the written consent of E.H. Wachs Company.

Chapter 1

About This Manual

PURPOSE OF THIS MANUAL

This manual explains how to operate and maintain your WTP4800 Hydraulic Trash Pump. It includes instructions for set-up, operation, and routine maintenance. It also contains parts lists, assembly diagrams, and troubleshooting instructions to help you order replacement parts and perform user-serviceable repairs.

Before operating your WTP4800 Hydraulic Trash Pump, you should read through this manual and become familiar with all instructions. At a minimum, make sure you read and understand the following chapters:

- Chapter 1, About This Manual
- Chapter 2, Safety
- Chapter 3, Introduction
- Chapter 5, Operating Instructions.

If you will be performing service or repairs, make sure you read and understand these chapters:

- Chapter 1, About This Manual
- Chapter 4, Assembly, Disassembly, and Storage
- Chapter 6, Routine Maintenance
- Chapter 7, Service and Repair.

You will also want to refer to Chapter 8, Parts Lists and Drawings.

In This Chapter

PURPOSE OF THIS MANUAL

HOW TO USE THE MANUAL

SYMBOLS AND WARNINGS

MANUAL UPDATES

Throughout this manual, refer to this column for warnings, cautions, and notices with supplementary information.

HOW TO USE THE MANUAL

This manual is organized to help you quickly find the information you need. Each chapter describes a specific topic on using or maintaining your WTP4800 Hydraulic Trash Pump.

Each page is designed with two columns. This large column on the inside of the page contains instructions and illustrations. Use these instructions to operate and maintain your WTP4800 Hydraulic Trash Pump.

The narrower column on the outside contains additional information such as warnings, special notes, and definitions. Refer to it for safety notes and other information.

SYMBOLS AND WARNINGS

The following symbols are used throughout this manual to indicate special notes and warnings. They appear in the outside column of the page, next to the section they refer to. Make sure you understand what each symbol means, and follow all instructions for cautions and warnings.



This is the safety alert symbol. It is used to alert you to potential personal injury hazards. Obey all safety messages that follow this symbol to avoid possible injury or death.



NOTE

This symbol indicates a user notice. **Notices** provide additional information to supplement the instructions, or tips for easier operation.

MANUAL UPDATES AND REVISION TRACKING

Occasionally, we will update manuals with improved operation or maintenance procedures, or with corrections if necessary. Revised chapters will be available for customers. If you receive revised chapters for your manual, remove the old chapters from your binder and replace them with the new chapters.

When a manual is revised, we will update the revision history on the title page and at the bottom of the pages in the revised chapters. It is important to put the current title page with the revision history in your manual. This will help you make sure you have all current information.

You may have factory service or upgrades performed on your equipment. If this service changes any technical data or operation and maintenance procedures, we will include revised sections of the manual when we return the equipment to you. Remove the old chapters from your manual and replace them with the revised chapters.

Current versions of E.H. Wachs Company manuals are also available in PDF format. You can request an electronic copy of this manual by emailing customer service at sales@wachsco.com.



Chapter 2

Safety

.....

The E.H. Wachs Company takes great pride in designing and manufacturing safe, high-quality products. We make user safety a top priority in the design of all our products.

WARNING

Read this chapter carefully before operating your WTP4800 Hydraulic Trash Pump. Serious injury or death could result from improper repair or service of this equipment.

Repair and/or service to this equipment must only be done by an authorized and certified dealer.

OPERATOR SAFETY

Follow these guidelines for safe operation of any mechanical equipment associated with the data logger.

- **READ THE OPERATING MANUAL.** Make sure you understand all setup and operating instructions before you begin.
- **INSPECT MACHINE AND ACCESSORIES.** Before starting the machine, look for loose bolts or nuts, leaking lubricant, rusted components, and any other physical conditions that may affect operation. Properly maintaining the machine can greatly decrease the chances for injury.

In This Chapter

OPERATOR SAFETY

SAFETY LABELS

SAFETY PRECAUTIONS

MACHINE SAFETY



Look for this symbol throughout the manual. It indicates a personal injury hazard.

- **ALWAYS READ PLACARDS AND LABELS.** Make sure all placards, labels, and stickers are clearly legible and in good condition. You can purchase replacement labels from E.H. Wachs Company.
- **KEEP CLEAR OF MOVING PARTS.** Keep hands, arms, and fingers clear of all rotating or moving parts. Always turn machine off before doing any adjustments or service.
- **SECURE LOOSE CLOTHING AND JEWELRY.** Secure or remove loose-fitting clothing and jewelry, and securely bind long hair, to prevent them from getting caught in moving parts of the machine.
- **KEEP WORK AREA CLEAR.** Keep all clutter and nonessential materials out of the work area. Only people directly involved with the work being performed should have access to the area.

Safety Symbols



This icon is displayed with any safety alert that indicates a personal injury hazard.

WARNING

This safety alert indicates a potentially hazardous situation that, if not avoided, **could** result in **death or serious injury**.

CAUTION

This safety alert, with the personal injury hazard symbol, indicates a potentially hazardous situation that, if not avoided, **could** result in **minor or moderate injury**.

NOTICE

This alert indicates a situation that, if not avoided, **will** result in **damage to the equipment**.

IMPORTANT

This alert indicates a situation that, if not avoided, **may** result in **damage to the equipment**.

SAFETY LABELS

The safety tag illustrated below is attached to the pump when it is shipped from the factory. Read and understand the instructions listed on this tag before you remove it. We suggest you retain this tag and attach it to the tool when it is not in use.

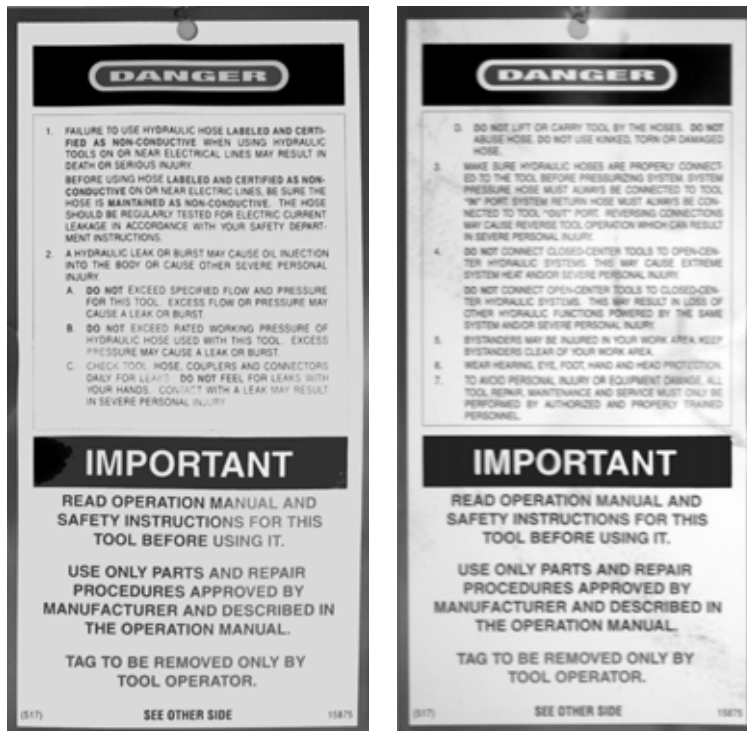

Figure 2-1. The front and back sides of the safety tag attached to the pump. (Tag is part no. STN-15875.)

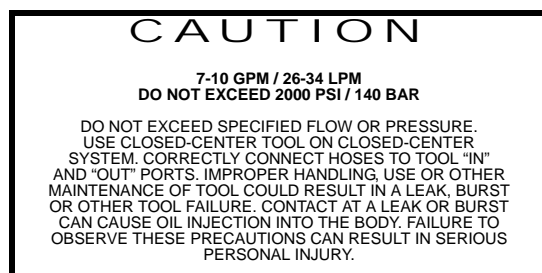

Figure 2-2. The GPM tag attached to the pump gives flow specifications. (Tag is part no. STN-03787.)

WARNING

Failure to follow the instructions for safe operation could result in operator injury.

**SAFETY PRECAUTIONS**

Tool operators and maintenance personnel must always comply with the safety precautions given in this manual and on the stickers and tags attached to the tool and hose.

These safety precautions are given for your safety. Review them carefully before operating the tool and before performing general maintenance or repairs.

Supervising personnel should develop additional precautions relating to the specific work area and local safety regulations. If so, place the added precautions in the space provided in this manual.

The model WTP4800 Hydraulic Trash Pump will provide safe and dependable service if operated in accordance with the instructions given in this manual. Read and understand this manual and any stickers and tags attached to the pump and hoses before operation. Failure to do so could result in personal injury or equipment damage.

- Operator must start in a work area without bystanders. The operator must be familiar with all prohibited work areas such as excessive slopes and dangerous terrain conditions.
- Establish a training program for all operators to ensure safe operations.
- Do not operate the tool unless thoroughly trained or under the supervision of an instructor.
- Always wear safety equipment such as goggles, head protection, and safety shoes at all times when operating the tool.
- Do not inspect or clean the tool while the hydraulic power source is connected. Accidental engagement of the tool can cause serious injury.
- Do not operate this tool without first reading the Operating Instructions.
- Do not install or remove this tool while the hydraulic power source is connected. Accidental engagement of the tool can cause serious injury.
- Never operate the tool near energized transmission lines. Know the location of buried or covered services before starting work.

- Do not wear loose fitting clothing when operating the tool. Loose fitting clothing can get entangled with the tool and cause serious injury.
- Supply hoses must have a minimum working pressure rating of 2500 psi/175 bar.
- Be sure all hose connections are tight.
- The hydraulic circuit control valve must be in the “OFF” position when coupling or uncoupling the tool. Wipe all couplers clean before connecting. Failure to do so may result in damage to the quick couplers and cause overheating. Use only lint-free cloths.
- Do not operate the tool at oil temperatures above 140° F/60° C. Operation at higher oil temperatures can cause operator discomfort and may cause damage to the tool.
- Do not operate a damaged, improperly adjusted, or incompletely assembled tool.
- To avoid personal injury or equipment damage, all tool repair, maintenance and service must only be performed by authorized and properly trained personnel.
- Do not exceed the rated limits of the tool or use the tool for applications beyond its design capacity.
- Always keep critical tool markings (such as labels and warning stickers) legible.
- Always replace parts with replacement parts recommended by the E.H. Wachs Company.
- Check fastener tightness often and before each use daily.
- Do not put your hands or any other body part under the volute while the trash pump is running.
- Do not point water discharge toward bystanders.

MACHINE SAFETY

Observe the following guidelines for reliable machine operation and care.

- Make sure all couplers are wiped clean before connection.
- The hydraulic circuit control valve must be in the “OFF” position when coupling or uncoupling hydraulic tools. Failure to do so may result in damage to the quick couples and cause overheating of the hydraulic system.
- Always store the tool in a clean dry space, safe from damage or pilferage.

NOTICE

Failure to follow the instructions for machine safety could result in damage to the equipment.

- Make sure the circuit PRESSURE hose (with male quick disconnect) is connected to the “IN” port. The circuit RETURN hose (with female quick disconnect) is connected to the opposite port. Do not reverse circuit flow. This can cause damage to internal seals.
- Always replace hoses, couplings, and other parts with replacement parts recommended by the E.H. Wachs Company. Supply hoses must have a minimum working pressure rating of 2500 psi (172 bar).
- Do not exceed the rated flow (see Specifications in Chapter 3) for correct flow rate and model number. Rapid failure of the internal seals may result.
- Always keep critical tool markings, such as warning stickers and tags, legible.
- Do not use the pump for applications for which it is not intended.
- Pump repair should be performed by experienced personnel only.
- Make certain that the recommended relief valves are installed in the pressure side of the system.
- Do not lift the trash pump by pulling on the hydraulic hoses. Use a suitable line fastened to the trash pump handle.

Chapter 3

Introduction to the WTP4800 Hydraulic Trash Pump

Read this chapter carefully to become familiar with the components and features of your WTP3500 hydraulic trash pump.

USAGE AND APPLICATIONS

The WTP4800 is a high-power trash pump with a flow rate of up to 800 gallons per minute (3028 l/min) and capacity for up to 4-inch (102 mm) solids. The pump is submersible, with no priming required, and can run dry without damage.

Figure 3-1 illustrates the components of the WTP4800 hydraulic trash pump.

In This Chapter

USAGE AND APPLICATIONS

REQUIREMENTS

PUMP SPECIFICATIONS

ACCESSORIES

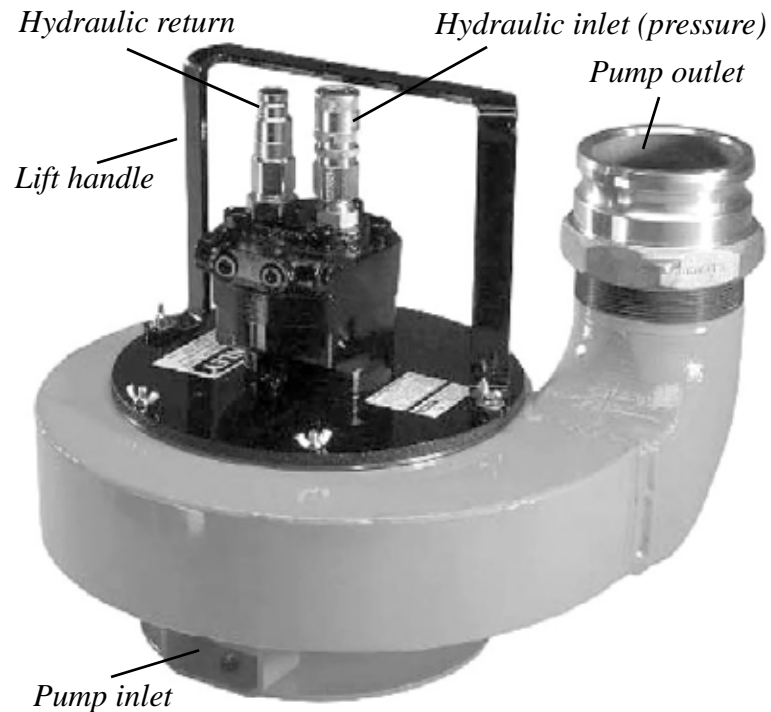

Figure 3-1. WTP4800 hydraulic trash pump components

Figure 3-2 illustrates the name tag fastened to the pump housing.

	E.H. Wachs Company 100 Shepard Street Wheeling, IL 60090 U.S.A.	
	Model No. WTP4800	26-38 LPM/7-10 GPM 140 BAR/2000 PSI

Figure 3-2. WTP4800 name tag (part no. 08-004-00).

REQUIREMENTS

Hydraulic Hose Requirements

Hose Types

The following hose types are approved for use with the WDP3500:

1. Certified non-conductive
2. Wire-braided (conductive)
3. Fabric-braided (not certified or labeled non-conductive).

Hose 1 listed above is the only hose authorized for use near electrical conductors.

Hoses 2 and 3 listed above are conductive and **must never** be used near electrical conductors.

Hose Safety Tags

The following DANGER tags are attached to all hoses supplied by the E.H. Wachs company for use with the WTP4800 pump. **DO NOT REMOVE THESE TAGS.**

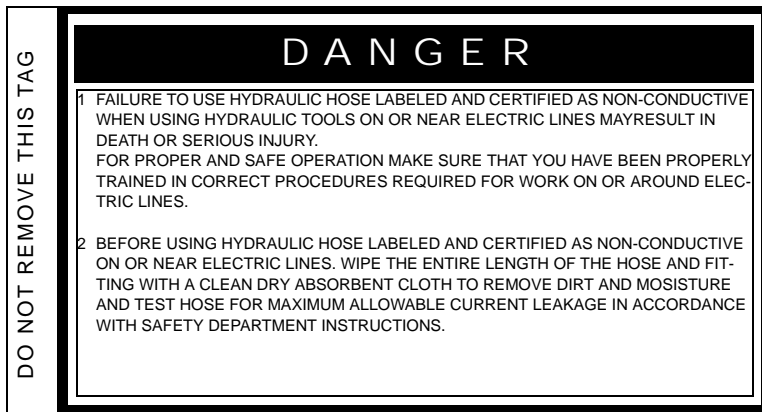

Figure 3-3. Tag attached to “Certified Non-Conductive” hose (front and back).



CAUTION:

If the information on a tag is illegible because of wear or damage, replace the tag immediately. A new tag may be obtained from your the E.H. Wachs Company.

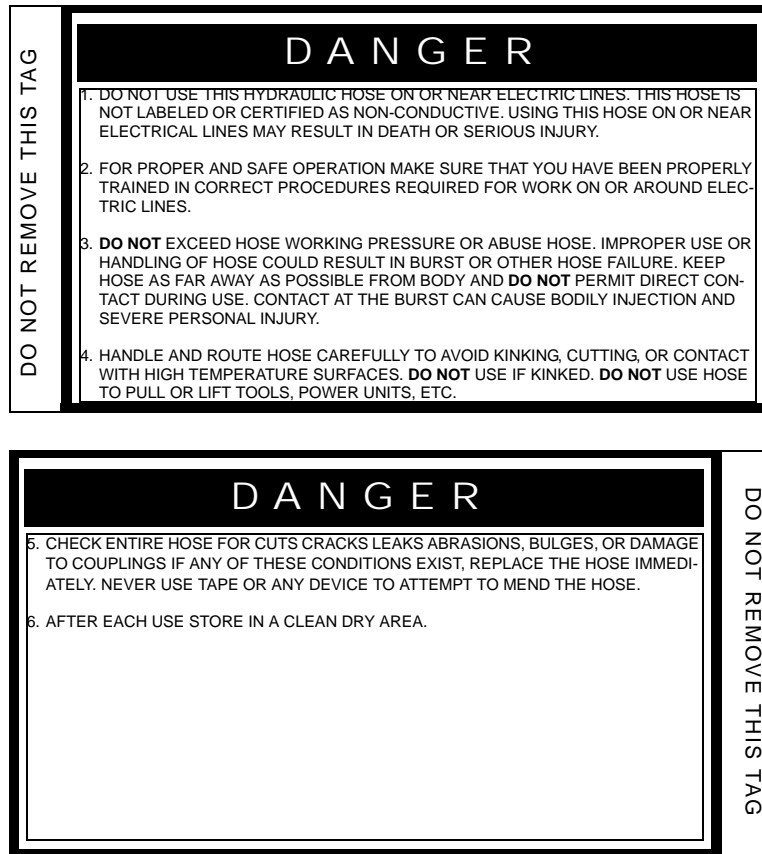



Figure 3-4. Tag attached to “Conductive” hose (front and back).

Hose Pressure Rating

The rated working pressure of the hydraulic hose must be equal to or higher than the relief valve setting on the hydraulic system.

HTMA Requirements

HYDRAULIC SYSTEM REQUIREMENTS	TOOL CATEGORY			
	 TYPE I	 TYPE II	TYPE III	TYPE RR
FLOW RATE	4-6 gpm (15-23 lpm)	7-9 gpm (26-34 lpm)	11-13 gpm (42-49 lpm)	9-10.5 gpm (34-40 lpm)
TOOL OPERATING PRESSURE (at the power supply outlet)	2000 psi (138 bar)	2000 psi (138 bar)	2000 psi (138 bar)	2000 psi (138 bar)
SYSTEM RELIEF VALVE SETTING (at the power supply outlet)	2100-2250 psi (145-155 bar)	2100-2250 psi (145-155 bar)	2100-2250 psi (145-155 bar)	2200-2300 psi (152-159 bar)
MAXIMUM BACK PRESSURE (at tool end of the return hose)	250 psi (17 bar)	250 psi (17 bar)	250 psi (17 bar)	250 psi (17 bar)
Measured at a max. fluid viscosity of: (at min. operating temperature)	400 ssu* (82 centistokes)	400 ssu* (82 centistokes)	400 ssu* (82 centistokes)	400 ssu* (82 centistokes)
TEMPERATURE Sufficient heat rejection capacity to limit max. fluid temperature to: (at max. expected ambient temperature)	140° F (60° C)	140° F (60° C)	140° F (60° C)	140° F (60° C)
Min. cooling capacity at a temperature difference of between ambient and fluid temps	3 hp (2.24 kW) 40° F (22° C)	5 hp (3.73 kW) 40° F (22° C)	7 hp (4.47 kW) 40° F (22° C)	6 hp (5.22 kW) 40° F (22° C)
NOTE: Do not operate the tool at oil temperatures above 140° F (60° C). Operation at higher temperatures can cause operator discomfort at the tool.				
FILTER Min. full-flow filtration Sized for flow of at least: (For cold temp. startup and max. dirt-holding capacity)	25 microns 30 gpm (114 lpm)	25 microns 30 gpm (114 lpm)	25 microns 30 gpm (114 lpm)	25 microns 30 gpm (114 lpm)
HYDRAULIC FLUID Petroleum based (premium grade, anti-wear, non-conductive) VISCOSITY (at min. and max. operating temps)	100-400 ssu*	100-400 ssu* (20-82 centistokes)	100-400 ssu*	100-400 ssu*
NOTE: When choosing hydraulic fluid, the expected oil temperature extremes that will be experienced in service determine the most suitable temperature viscosity characteristics. Hydraulic fluids with a viscosity index over 140 will meet the requirements over a wide range of operating temperatures.				

*SSU = Saybolt Seconds Universal

NOTE:
These are general hydraulic system requirements. See tool Specification page for tool specific requirements.

PUMP SPECIFICATIONS

Capacity	800 gpm/3028 lpm
Weight	59 lbs/26.7 kg
Height (over handle)	16.5 in./42 cm
Length	19 in./48.3 cm
Width	15 in./38.1 cm
Pressure	2000 psi/140 bar
Flow Range	7-10 gpm/26-38 lpm
Maximum Flow	10 gpm/38 lpm
Porting	#10 SAE (pressure); #12 SAE (return)
Connect Size and Type	1/2 in. male pipe (pressure) 1/2 in. male pipe (return)
Discharge Diameter	4 in./100 mm camlock
Inlet Diameter	4 in./100 mm

ACCESSORIES

- Lay-flat discharge hose, 4 in. x 25 ft with camlock fittings (part no. 08-400-04).

Chapter 4

Assembly, Disassembly, and Storage

.....

The WTP4800 hydraulic sump pump is shipped fully assembled from the factory. It is ready to operate as soon as you remove it from its shipping/storage case.

CARE OF HYDRAULIC HOSES/CONNECTORS

Before storing the pump (either short-term or long-term), securely fasten protective caps over the hydraulic connectors on the pump. Also install caps on the hoses, or connect the male and female ends of the hose together to seal the connectors and keep dirt and contaminants out of the hoses.

ENVIRONMENTAL REQUIREMENTS

The pump should not be used to pump volatile liquids, or water containing volatiles.

If you use the pump in a corrosive environment, be sure to clean it thoroughly. If possible, pump clean water through to rinse the interior components, and spray the outside of the pump.

LONG-TERM STORAGE

Always store the pump in a clean, dry place safe from damage.

In This Chapter

CARE OF HYDRAULIC HOSES/
CONNECTORS

ENVIRONMENTAL
REQUIREMENTS

LONG-TERM STORAGE



Chapter 5

Operating Instructions

PRE-OPERATION PROCEDURES

Check Power Source

1. Using a calibrated flow meter and pressure gauge, make sure the hydraulic power source develops a flow of 7-10gpm (26-38 lpm) at 2000 psi (140 bar).
2. Make certain that the power source is equipped with a relief valve set to open at 2100-2250 psi (145-155 bar) maximum.
3. Make certain that the power source return pressure does not exceed 250 psi (17 bar).
4. Make sure the pump inlet is clear of debris. Remove any obstruction before operating. Refer to the pump cleaning procedures in Chapter 6.

Connect Hoses

1. Wipe all hose couplers with a clean, lint free cloth before making connections.
2. Connect the hoses from the hydraulic power source to the couplers on the pump or hoses. It is a good practice to connect the return hose first and disconnect it last to minimize or avoid trapped pressure within the pump motor.

In This Chapter

PRE-OPERATION PROCEDURES

PUMP OPERATION

COLD WEATHER OPERATION



If uncoupled hoses are left in the sun, pressure increase inside the hoses might make them difficult to connect. Whenever possible, connect the free ends of the hoses together.

NOTICE:

Do not connect pressure to the return port. Motor shaft seal limit is 250 psi (17 bar).

WARNING:

Never point the hose at bystanders. Personal injury could result.



It will not damage the pump to operate it "dry."



3. Observe the arrow on the couplers to ensure that the flow is in the proper direction. The female coupler on the pump is the inlet (pressure) coupler.

PUMP OPERATION

1. Observe all safety precautions.
2. Attach a discharge hose (part no. 08-400-04) to the trash pump outlet. For best performance, keep the hose as short as possible and lay it out to avoid sharp bends or kinks.
3. Attach a rope or cable to the pump's handle. Lower the pump into the liquid to be pumped. Do not raise or lower the trash pump by its hoses or couplers.
4. Turn on the hydraulic power source. Watch for solids in the liquid being pumped. If solids are excessive, the discharge flow might decrease. If this happens, stop the pump and check for the cause of the problem.

Under some conditions, the liquid being pumped might be slowed enough so it can no longer push particles in the liquid. If this happens, particles can accumulate in the pumping chamber, causing further restriction. The impeller then acts as a "grinding wheel," which causes accelerated pump wear. Reduced liquid flow can be caused by the following:

- The pump sinks into solids at the bottom of the hole.
 - The end of the outlet hose is too high, causing an excessive lift height for the column of liquid being pushed by the pump. This slows the flow of liquid to a level where it can no longer carry solids out the end of the hose.
 - The flow and pressure of hydraulic fluid to the pump is too low, which reduces impeller speed. A 20% decrease in hydraulic fluid flow can reduce pump performance by 50%. When operating at reduced hydraulic flow and pressure, the end of the outlet hose should not be more than 30 ft (9 m) above the liquid.
5. When pumping is complete, set the hydraulic control valve to the "OFF" position. Lift the pump from the work area using the attached rope or cable.
 6. The pump must maintain a minimum impeller speed

in order to move solid particles through the pump. While pumping liquids containing large solids, monitor the flow from the outlet of the fire hose. If it begins to slow, turn off the hydraulic power source and lift the trash pump from the work area. Disconnect the hydraulic hoses and clean out the water hose and pumping chamber.

7. To maintain optimum performance, it is good practice to periodically inspect the impeller for wear or damage. This is especially important following the pumping of liquids containing sharp, abrasive solids.

COLD WEATHER OPERATION

If the pump is to be used during cold weather, preheat the hydraulic fluid at low power source speed. When using the normally recommended fluids, fluid should be at or above 50°F (10° C) (400 ssu/82 centistokes) before use. Damage to the hydraulic system or pump motor seals can result from use with fluid that is too viscous or thick.

NOTICE:

Pumping liquids with a solids content of greater than 30 percent will cause accelerated impeller wear.



Chapter 6

Routine Maintenance

Good maintenance practice keeps the trash pump on the job and increases its service life. Use the procedures in this chapter to clean and inspect the pump, and refer to Chapter 7 for any required repair procedures.

The most important maintenance practice is to keep the hydraulic fluid clean at all times. Contaminated hydraulic fluid causes rapid wear and/or failure of internal parts. Follow the procedures contained in the Hydraulic System Requirements in Chapter 3 to ensure peak performance from the trash pump.

PUMP CLEANING AND INSPECTION

Debris such as weeds, sand and other solids may become trapped in the pumping chamber. This can reduce pump performance. It is important that the pumping chamber be kept clean at all times.

Clean out the debris and then determine whether or not the fire hose is clogged or the power source is not providing adequate flow/pressure to properly drive the trash pump. If the trash pump is not cleared, heavy solids will not be removed from the trash pump, eventually damaging or destroying the impeller.

In This Chapter

PUMP CLEANING AND
INSPECTION

Cleaning the Hose and Pumping Chamber

1. Remove the water hose from the trash pump. If it is clogged, lift near the outlet end of the hose and then shake it to loosen any debris. Continue shaking while working toward the inlet end until the entire water hose is free of all debris.
2. Look into the pump outlet and inlet (bottom) and remove any debris. If you are unable to clear the debris, you must open the trash pump.

Opening the Pump

1. Disconnect the hydraulic hoses from the pump.
2. Remove the six 1/4-20 wing nuts securing the handle and volute/motor mount plate to the volute weldment. Lift the volute/motor mount plate from the volute weldment and place it on a clean, flat work surface.
3. Remove the shim(s) from the top of the volute weldment.
4. Clean out the pumping chamber.
5. Remove any debris from the water outlet and inlet.

Inspecting the Impeller

1. Check the impeller blades for cracks, chips and signs of excessive wear. Also, see if it has been rubbing against the bottom wear plate. If the impeller is excessively worn, it must be replaced. Refer to the disassembly instructions in Chapter 7.

Note: There should be a close fit between the impeller and the bottom wear plate. However, there should not be any drag.

2. If there is excessive drag, add a shim between the volute weldment and the volute/motor mount plate.
3. If the clearance between the volute weldment and the bottom wear plate exceeds 1/16 of an inch, remove a shim to achieve a closer fit.

4. If hydraulic fluid appears above the impeller, the motor shaft seal has failed. Refer to the motor shaft seal disassembly instructions in Chapter 7.

Inspecting the Bottom Wear Plate

1. Check the bottom wear plate for cracks, deep scratches and signs of excessive wear. Scratches deeper than 1/16 inch (2 mm) might affect pump performance.
2. If the wear plate is not damaged, add or remove shim(s) as required to achieve a proper fit.
3. If the wear plate is damaged, it must be replaced.

Preparing the Pump for Operation

If no other service is required, prepare the pump for normal operation:

1. Remove the grease fitting cap and inject two pumps of underwater grease into the lip excluder housing.
2. Replace the grease fitting cap.
3. Replace the shim(s) onto the top of the volute weldment.
4. Place the volute/motor mount plate onto the volute weldment.
5. Secure the volute/motor mount plate to the volute weldment using the six 1/4-20 wing nuts.



Chapter 7

Service and Repair

For the procedures in this chapter, refer to the parts drawing on the next page. The reference numbers on the drawing are keyed to the parts list in Chapter 8.

PUMP DISASSEMBLY

The following procedures should be performed only if:

- It is determined (after a complete inspection) that the trash pump power module (motor) is malfunctioning.
- Hydraulic fluid is leaking between the motor cap assembly and the bearing carrier assembly.
- Hydraulic fluid is leaking from the motor shaft.
- The shafts and gears need to be replaced.

Clean the exterior of the trash pump and put it on a clean work surface.

Before disassembling the pump, obtain the Seal Kit (part number STN-22546) to replace all seals exposed during disassembly.

Remove Impeller

1. Open the trash pump. Refer to the pump cleaning procedures provided in Chapter 6.
2. Place the motor in a soft vise with the impeller facing up.

In This Chapter

PUMP DISASSEMBLY

CLEANING AND INSPECTION

PUMP REASSEMBLY

TROUBLESHOOTING



Note the orientation of the seals before removing them. Make sure to install new seals the same way they were removed.

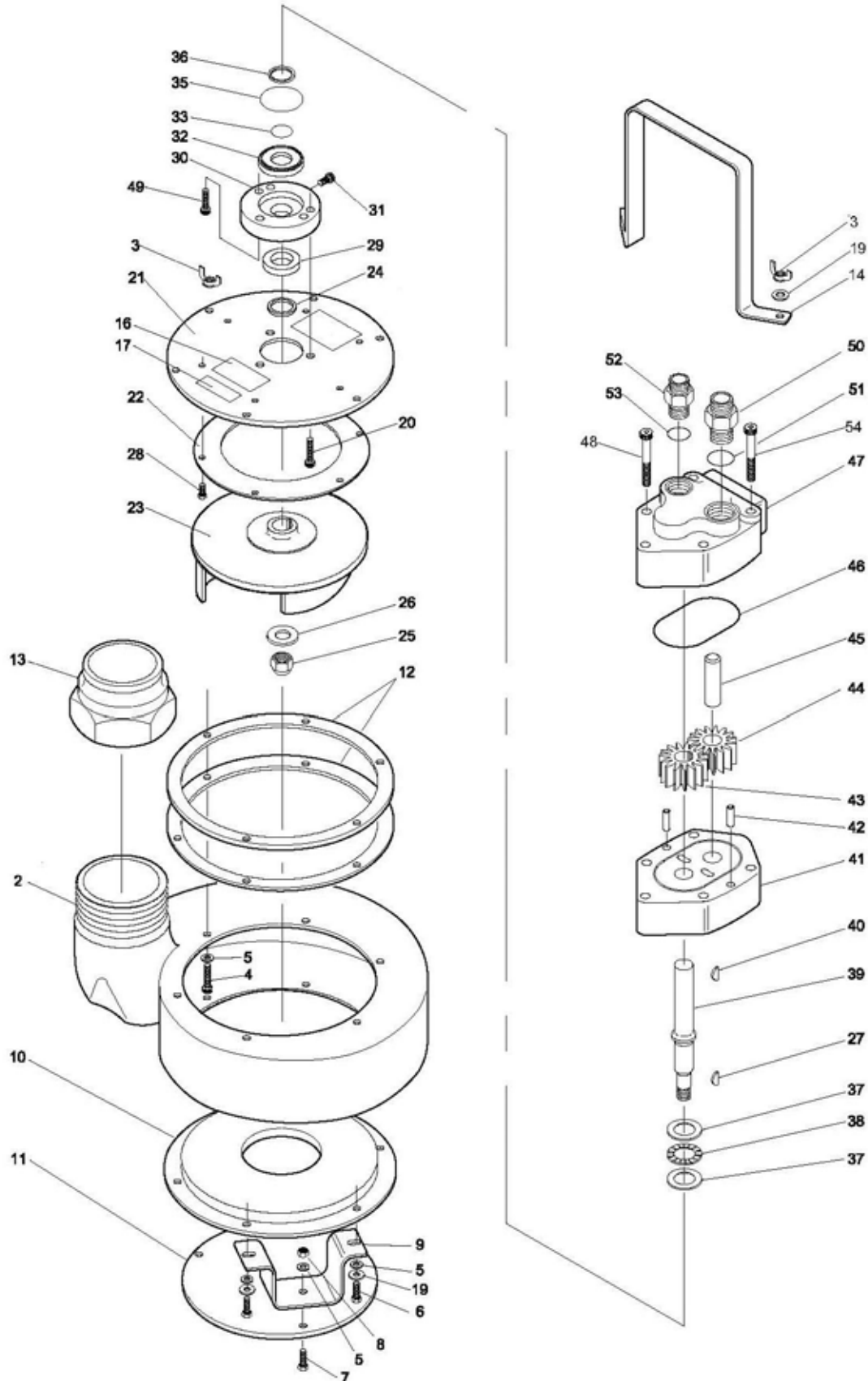

3. Remove the nut and washer securing the impeller to the motor shaft.
4. Carefully pull the impeller off of the motor shaft.
5. Check the impeller blades for cracks, chips and signs of excessive wear which can affect pump performance. Replace the impeller if damaged, seriously worn, or out of balance.

Replace Impeller

1. Grease the woodruff key, impeller bore, and motor shaft with underwater grease.
2. Replace the woodruff key.
3. Slip the impeller onto the motor shaft.
4. Secure the impeller to the motor shaft using the washer and nut.

Replace Motor Shaft Seal

1. Remove the impeller according to the procedure earlier in this section.
2. Remove the six 1/4-20 x 1/2 in (13 mm) flat head capscrews securing the top wear plate to the volute/motor mount plate.
3. Remove the three 3/8 x 1-3/4 in (44.5 mm) flat hex head capscrews securing the volute/motor mount plate to the power module.
4. Check the top wear plate for cracks, deep scratches, and signs of excessive wear. Scratches deeper than 1/16 in (2 mm) might affect pump performance.
5. If the wear plate is damaged, it must be replaced.
6. Remove the excluder, v-ring, and seal anvil from the bottom of the housing lip excluder.
7. Remove the two 3/8-16 x 1-1/4 in (32 mm) socket head capscrews securing the housing lip excluder to the bearing carrier assembly.
8. Hold the motor shaft in (to prevent bearing damage) while removing the housing lip excluder and enclosed



The woodruff key might fall out of the motor shaft key-way. Make sure it is not lost.

- parts from the bearing carrier housing and the motor shaft.
9. Remove the retainer ring, seal, and o-ring from the seal carrier.
 10. If the seal anvil has been damaged, it can be pressed out from the inside and then replaced.
 11. Inspect the motor shaft surface where the bronze seal carrier was installed. If the motor shaft is damaged, it must be replaced. Refer to the Motor Disassembly section later in this chapter.
 12. Using clean underwater grease and new seals from the Seal Kit (part number STN-22546), lubricate the seal carrier, seal, and o-ring, then install into the seal carrier. The greased seal will squeeze into the seal carrier and **MUST NOT BE TWISTED** or it will not seal.
 13. Grease the motor shaft, then place the seal carrier with the O.D. o-ring side going on first over the motor shaft.
 14. Place the seal carrier (with seal anvil) over the motor shaft.
 15. Push the seal retainer up against the bearing carrier assembly.
 16. Secure the seal carrier housing to the bearing carrier assembly using two 3/8-16 x 1-1/4 in (32 mm) socket head capscrews. Tighten the capscrews to a torque value of 18 lb-ft (24.3 Nm).
 17. Secure the top wear plate to the volute/motor mount plate using the six 1/4-20 x 1/2 in (13 mm) flat head capscrews.
 18. Lubricate and install the excluder lip seal over the motor shaft with the lip pressed against the anvil pocket.
 19. Replace the impeller. Refer to the **IMPELLER REPLACEMENT** procedures provided earlier in this section.

Disassemble Motor

1. Remove the two 1/2-13 x 2-3/4 in (70 mm) and the three 1/2-13 x 2-1/4 in (57 mm) capscrews securing the motor cap assembly to the bearing carrier assembly.
2. Carefully lift the motor cap assembly away from the bearing carrier assembly.
3. Remove the o-ring from inside the motor cap assembly.

CLEANING AND INSPECTING MOTOR CHAMBER AND PARTS

Inspect and clean all parts as follows:

Cleaning Guidelines

Clean all parts with a degreasing solvent.

Blow dry all parts with compressed air and wipe clean. Use only lint-free cloths.

Gears

The gears should have straight tips without nicks, square tooth ends, and smooth even polish on the teeth and end surfaces. Check for cracks at the groove in the drive gear bore.

Motor Cap Assembly

The surface near the gears should show two overlapping polished circles without a step. The bottom of the o-ring groove should be smooth as should the rest of the flat surface.

Motor Shaft

The diameter should be smooth on each side of the keyway. Signs of polishing are normal. Grooves, roughness or a reduced diameter are indications of fluid contamination. Replace the seals if the motor shaft requires replacement.

If the motor shaft must be removed, refer to the Replace the Motor Shaft Seal section to remove the needle bearing. In addition, the key must also be removed from the motor shaft keyway before removing the motor shaft.

Check the hydraulic system for excess contamination in the fluid and for filter condition. Operating conditions might



The key might fall out of the motor shaft keyway.

Make sure it is not lost. Also, the gears and idler shaft might remain in the motor cap assembly. Do not drop or damage them.



The motor shaft and needle bearing are separated by removing the retaining ring. When separating, make sure you do not scratch any seal areas.

require changing from a 25 micron filter to an oversized 10 micron filter.

PUMP REASSEMBLY

Assemble Motor

1. If the motor shaft was replaced, install the two bearing races and thrust bearing onto the motor shaft.
2. Using clean underwater grease, grease the motor shaft and then insert it through the lower end of the bearing carrier assembly.
3. Replace the motor shaft seal parts according to the procedure earlier in this chapter.
4. Using clean underwater grease, grease the keyway and motor shaft. Replace the key and then place the drive gear over the key.
5. Install the idler shaft and idler gear assembly onto the flat motor surface of the bearing carrier.
6. Lubricate and install the o-ring into the motor cap assembly groove.
7. Slide the motor cap assembly over the gears and shafts until completely down flat. **DO NOT TIP CAP OR FORCE IT OVER GEARS.**
8. Secure the motor cap assembly to the bearing carrier assembly using the two greased 1/2-13 x 2-3/4 in (70 mm) and the three greased 1/2-13 x 2-1/4 in (57 mm) capscrews. Tighten each capscrew to a torque value of 60 lb-ft (81.4 Nm).

Assemble Pump

1. Clean all parts with a degreasing solvent.
2. Make sure all seals that were exposed have been replaced with new parts.
3. Apply clean underwater grease to all parts during assembly.
4. Secure the top wear plate to the volute/ motor mount plate using the six 1/4-20 x 1/2 in (13 mm) flat head capscrews.

5. Grease the woodruff key, impeller bore, and motor shaft with underwater grease.
6. Replace the woodruff key and then slip the impeller onto the motor shaft.
7. Secure the impeller to the motor shaft using the washer and nut.
8. Prepare the trash pump for normal operation according to the procedure in Chapter 6.

TROUBLESHOOTING

Refer to the troubleshooting chart on the following page.

TROUBLESHOOTING

If symptoms of poor performance develop, the following chart can be used as a guide to correct the problem.

When diagnosing faults in operation of the tool, always make sure the hydraulic power source is supplying the correct hydraulic flow and pressure as listed in the table. Use a flowmeter know to be accurate. check the flow with the hydraulic fluid temperature at least 80° F/27° C.

PROBLEM	CAUSE	SOLUTION
Pump will not start.	No hydraulic fluid flow or pressure.	Turn on power unit and check that 7-10 gpm/26-38 lpm at 2000 psi/140 bar is available at the trash pump.
	Defective couplers.	Check the couplers by connecting them together with the hydraulic power supply operating and with the control valve in the "ON" position. The power supply should operate without "loading" from the couplers.
	Impeller jammed with debris.	Clean the pumping chamber.
	Impeller rubbing against wear plates.	Check and adjust the impeller clearance.
	Defective power module.	Repair or replace the power module.
Poor pump performance.	Hydraulic flow reversed.	Check that the hoses are correctly connected to the pump motor ports. The female coupler should be connected to the "IN" port. The return fluid must never flow through a reversing valve.
	Improper hydraulic fluid flow.	Check that 7-10 gpm/26-38 lpm at 2000 psi/140 bar is available at the trash pump. A 20% decrease in flow can result in a 50% decrease in pump performance. 8 gpm/30 lpm is the best circuit flow.
	Trash pump submersed in sediment.	Lift the pump from the bottom of the hole or chamber. Use a flat support under the pump if necessary.
	Trash pump inlet restricted.	Remove restriction and thoroughly clean.
	Discharge hose kinked or restricted.	Straighten the hoses. If the hose must bend at the top of the hole, use a piece of split rigid conduit with large diameter of the expanded hose. This keeps the hose from kinking. Use a 90° 4-inch pipe elbow on the trash pump outlet if necessary.
	Discharge hose too small.	Use a 4-inch diameter fire hose.
	Water lift too high.	Lower the outlet end of the discharge hose.
	Impeller worn or damaged.	Check impeller for damage and excessive wear. Replace if necessary.
	Wear plates worn or damaged.	Check wear plates for damage and excessive wear. Replace if necessary.
Hydraulic fluid in discharge flow.	Motor shaft seal failure.	Replace the motor shaft seal. Ensure power unit is delivering 7-10 gpm/26-38 lpm

Chapter 8

Parts Lists and Drawings



Refer to the drawing and the parts list on the following pages for ordering spare and replacement parts.



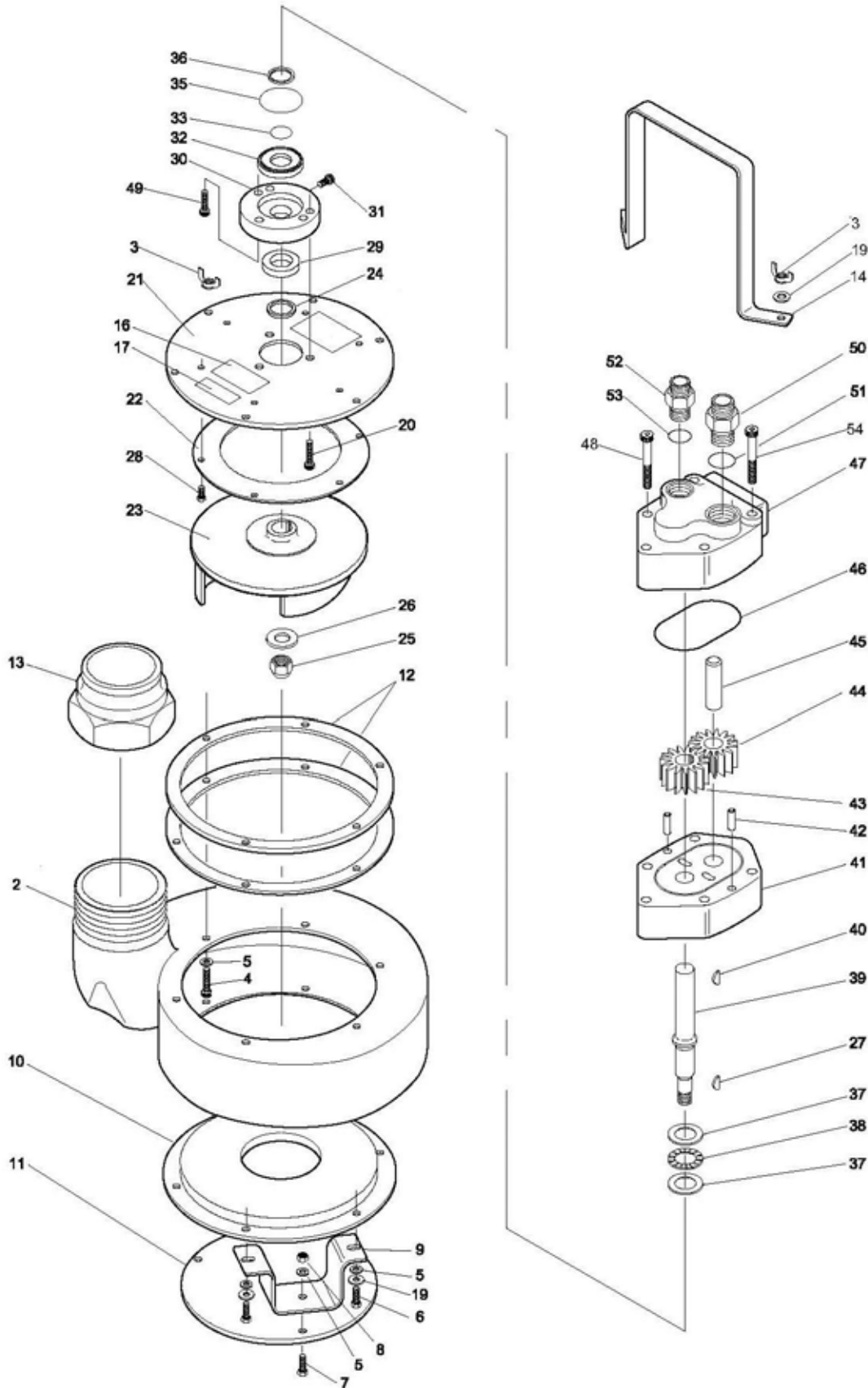

Table 1: WTP4800 Parts List

Item No.	Part No.	Qty	Description
1	STN-31505	1	Motor Assembly (incl. 20, 24, 29-48)
2	STN-21960	1	Volute Weldment
3	STN-21961	6	Wing Nut
4	STN-65783	6	Capscrew
5	STN-01324	12	Lockwasher
6	STN-08937	6	Capscrew (TP08013 only)
	STN-15476	6	Capscrew (TP0801302 only)
7	STN-15476	3	Capscrew
8	STN-00788	3	Hex Nut
9	STN-21963	3	Brace
10	STN-21964	1	Wear Plate
11	STN-21965	1	Base
12	STN-21966	A/R	Shim
13	STN-21967	1	Male Camlock
14	STN-21968	1	Handle
15	---	---	NO ITEM
16	STN-03787	1	Sticker, GPM
17	08-004-00	1	Sticker, Name Tag
18	STN-15875	1	Warning Tag (Not Shown)
19	STN-15664	8	Washer
20	STN-21978	3	Capscrew
21	STN-21977	1	Plate—Volute/Motor Mount
22	STN-21993	1	Wear Plate Top
23	STN-21979	1	Impeller
24	STN-06311	1	V-Ring
25	STN-21988	1	Acorn Nut
26	STN-03827	1	Washer
27	STN-00600	1	Woodruff Key
28	STN-21989	6	Capscrew
29	STN-21981	1	Seal Anvil
30	STN-21976	1	Housing Lip Excluder
31	STN-01220	1	Grease Fitting
32	STN-31266	1	Seal Carrier
33	STN-21021	1	Seal
34	---	---	NO ITEM
35	STN-01872	1	O-Ring
36	STN-26812	1	Retaining Ring
37	STN-20680	2	Bearing Race
38	STN-08020	1	Thrust Bearing
39	STN-21971	1	Motor Shaft
40	STN-21985	1	Key
41	STN-20691	1	Bearing Carrier
42	STN-22065	2	Dowel Pin

Table 1: WTP4800 Parts List

Item No.	Part No.	Qty	Description
43	STN-21974	1	Drive Gear
44	STN-21983	1	Idler Gear
45	STN-21984	1	Idler Shaft
46	STN-15385	1	O-Ring
47	STN-21972	1	Motor Cap Assembly
48	STN-21986	3	Capscrew
49	STN-10793	2	Capscrew
50	STN-06264	1	Adapter
51	STN-06891	1	O-Ring (Supplied with Item 50)
52	STN-07882	1	Adapter
53	STN-01604	1	O-Ring (Supplied with Item 52)
54	STN-21987	2	Capscrew
	STN-22546	1	Seal Kit

Chapter 9

Accessories

.....

Table 1 lists accessories available for the WTP4800 hydraulic trash pump.

Part No.	Description	
08-400-04	Lay-flat discharge hose, 4 in. x 25 ft. with cam-lock fittings	<i>(no photo available)</i>

Table 1: Accessories for WTP4800 Hydraulic Trash Pump

Chapter 10

Ordering Information

.....

To place an order, request service, or get more detailed information on any E.H. Wachs Company products, call us at one of the following numbers:

U.S. 800-323-8185
International: 847-537-8800

ORDERING REPLACEMENT PARTS

When ordering parts, refer to the parts lists in Chapter 8. Please provide the part description and part number for all parts you are ordering.

REPAIR INFORMATION

Please call us for an authorization number before returning any equipment for repair or factory service. We will advise you of shipping and handling. When you send the equipment, please include the following information:

- Your name/company name
- Your address
- Your phone number
- A brief description of the problem or the work to be done.

Before we perform any repair, we will estimate the work and inform you of the cost and the time required to complete it.

In This Chapter

REPLACEMENT PARTS

REPAIR INFORMATION

WARRANTY INFORMATION

RETURN GOODS ADDRESS

WARRANTY INFORMATION

Enclosed with the manual is a warranty card. Please fill out the registration card and return to E.H. Wachs Company. Retain the owner's registration record and warranty card for your information.

RETURN GOODS ADDRESS

Return equipment for repair to the following address.

E.H. Wachs Company
100 Shepard Street
Wheeling, Illinois 60090 USA