



September 30, 2009
ML0027 Document Revision C
© 2009 by Bitronics, LLC

TABLE OF CONTENTS

M870D FIRMWARE REVISIONS.....	iii
70 SERIES MANUAL SET.....	iii
INSTALLATION AND MAINTENANCE.....	iv
WARRANTY AND ASSISTANCE.....	iv
Authorized representative in the European Union.....	v
COPYRIGHT NOTICE.....	v
TRADEMARKS.....	v
SAFETY SECTION.....	vii
WARNING: EMISSIONS - CLASS A DEVICE (N55011).....	ix
Decommissioning and Disposal.....	ix
1.0 Introduction.....	1
1.1 Features.....	1
1.2 Specifications.....	1
1.3 Environmental.....	1
1.4 Physical.....	2
1.5 Standards and Certifications.....	4
2.0 Installation.....	6
2.1 Initial Inspection.....	6
2.2 Instrument Mounting.....	6
2.3 Surge Protection.....	7
2.4 Overcurrent Protection.....	7
2.5 Supply/Mains Disconnect.....	8
2.6 Power Supply Connections.....	8
2.7 Cleaning.....	8
3.0 SETUP.....	9
3.1 Communications Connections.....	9
3.2 Setup Mode.....	12
3.3 Measurement Screens.....	13
3.4 Operation.....	15
3.4.1 Overview.....	15
3.4.2 Keypad.....	16
3.4.3 Tx/Rx LED.....	16
3.5 RS232 Service Port.....	16
4.0 Troubleshooting.....	17
4.1 Error/Informational Messages.....	17
5.0 Firmware Upgrades.....	17

M870D FIRMWARE REVISIONS

Display	Description	Date
v1.01.0	Initial Release	4/23/02
v1.02.0	Update	7/25/02
v1.04.0	Update – Baud rate max 38400	11/01/02
v1.05.0	Update – Setup Config. saved to EEPROM	6/03/03
v1.06.0	Update – Bug fix	9/15/03
v1.07.0	Update – Changed bootup text to AREVA	3/05/04
v1.08.0	M570D release, power up sequence	10/07/05

Bootloader	Description	Date
v1.00.0	Initial Release	4/23/02
v1.01.0	Update	7/25/02

70 SERIES MANUAL SET

ML0021	M87X User Manual
ML0022	70 Series UCA [®] Object Model
ML0024	M87X Modbus Plus Module & Protocol
ML0025	70 Series Modbus Protocol
ML0026	70 Series DNP3 Protocol
ML0027	M870D Remote Display Manual
ML0032	M57X User Manual
ML0033	M570Dx Remote Display Manual
ML0034	70 Series IEC 61850 Protocol Manual

CERTIFICATION

Bitronics LLC certifies that the calibration of our products is based on measurements using equipment whose calibration is traceable to the United States National Institute of Standards Technology (NIST).



INSTALLATION AND MAINTENANCE



Bitronics LLC products are designed for ease of installation and maintenance. As with any product of this nature, installation and maintenance can present electrical hazards and should be performed only by properly trained and qualified personnel. If the equipment is used in a manner not specified by Bitronics LLC, the protection provided by the equipment may be impaired.

In order to maintain UL recognition, the following Conditions of Acceptability shall apply:

- a) Terminals and connectors that shall be connected to hazardous live voltages are restricted to non-field wiring applications only.
- b) After installation, all hazardous live parts shall be protected from contact by personnel or enclosed in a suitable enclosure.

WARRANTY AND ASSISTANCE

This product is warranted against defects in materials and workmanship for a period of thirty-six (36) months from the date of their original shipment from the factory. Products repaired at the factory are likewise warranted for eighteen (18) months from the date the repaired product is shipped, or for the remainder of the product's original warranty, whichever is greater. Obligation under this warranty is limited to repairing or replacing, at our designated facility, any part or parts that our examination shows to be defective. Warranties only apply to products subject to normal use and service. There are no warranties, obligations, liabilities for consequential damages, or other liabilities on the part of Bitronics LLC except this warranty covering the repair of defective materials. The warranties of merchantability and fitness for a particular purpose are expressly excluded.

For assistance, contact Bitronics LLC at:

Telephone: 610.997.5100
Fax: 610.997.5450
Email: bitronics@novatechps.com
Website: www.novatechweb.com/bitronics

Shipping:

261 Brodhead Road
Bethlehem, PA 18017-8698
USA

AUTHORIZED REPRESENTATIVE IN THE EUROPEAN UNION

NovaTech Europe BVBA

Kontichsesteenweg 71

2630 Aartselaar

Belgium

T +32.3.458.0807

F +32.3.458.1817

E info.europe@novatechps.com

COPYRIGHT NOTICE

This manual is copyrighted and all rights are reserved. The distribution and sale of this manual is intended for the use of the original purchaser or his agents. This document may not, in whole or part, be copied, photocopied, reproduced, translated or reduced to any electronic medium or machine-readable form without prior consent of Bitronics LLC, except for use by the original purchaser.

The product described by this manual contains hardware and software that is protected by copyrights owned by one or more of the following entities:

Bitronics LLC, 261 Brodhead Road, Bethlehem, PA 18017;

VentureCom, Inc., Five Cambridge Center, Cambridge, MA 02142;

SISCO, Inc., 6605 192 Mile Road, Sterling Heights, MI 48314-1408;

General Software, Inc., Box 2571, Redmond, WA 98073;

Schneider Automation, Inc., One High Street, North Andover, MA 01845;

Triangle MicroWorks, Inc., 2213 Middlefield Court, Raleigh, NC 27615

Greenleaf Software Inc., Brandywine Place, Suite 100, 710 East Park Blvd, Plano, TX 75074

TRADEMARKS

The following are trademarks or registered trademarks of Bitronics LLC:

The Bitronics logo Bitronics PowerPlex Triplex Triple-II
MultiComm PowerServe SubCycle Technology SubCycleStuf

The following are trademarks or registered trademarks of AREVA T&D Inc.

AREVA T&D the AREVA logo MiCOM

The following are trademarks or registered trademarks of the DNP User's Group:

DNP DNP3

The following are trademarks or registered trademarks of the Electric Power Research Institute (EPRI):

UCA

The following are trademarks or registered trademarks of Schneider Automation, Inc.:

MODSOFT Modicon Modbus Plus Modbus Compact 984 PLC

The following are trademarks or registered trademarks of VentureCom, Inc.:

Phar Lap the Phar Lap logo

The following are trademarks or registered trademarks of Systems Integration Specialists Company, Inc. (SISCO):

SISCO MMS-EASE Lite AX-S4MMS

The following are trademarks or registered trademarks of General Software, Inc.:

General Software the GS logo EMBEDDED BIOS Embedded DOS

The following are trademarks or registered trademarks of the PCI Industrial Computer Manufacturers Group:

CompactPCI PICMG the CompactPCI logo the PICMG logo

SAFETY SECTION

This Safety Section should be read before commencing any work on the equipment.

Health and safety

The information in the Safety Section of the product documentation is intended to ensure that products are properly installed and handled in order to maintain them in a safe condition. It is assumed that everyone who will be associated with the equipment will be familiar with the contents of the Safety Section.

Explanation of symbols and labels

The meaning of symbols and labels that may be used on the equipment or in the product documentation is given below.

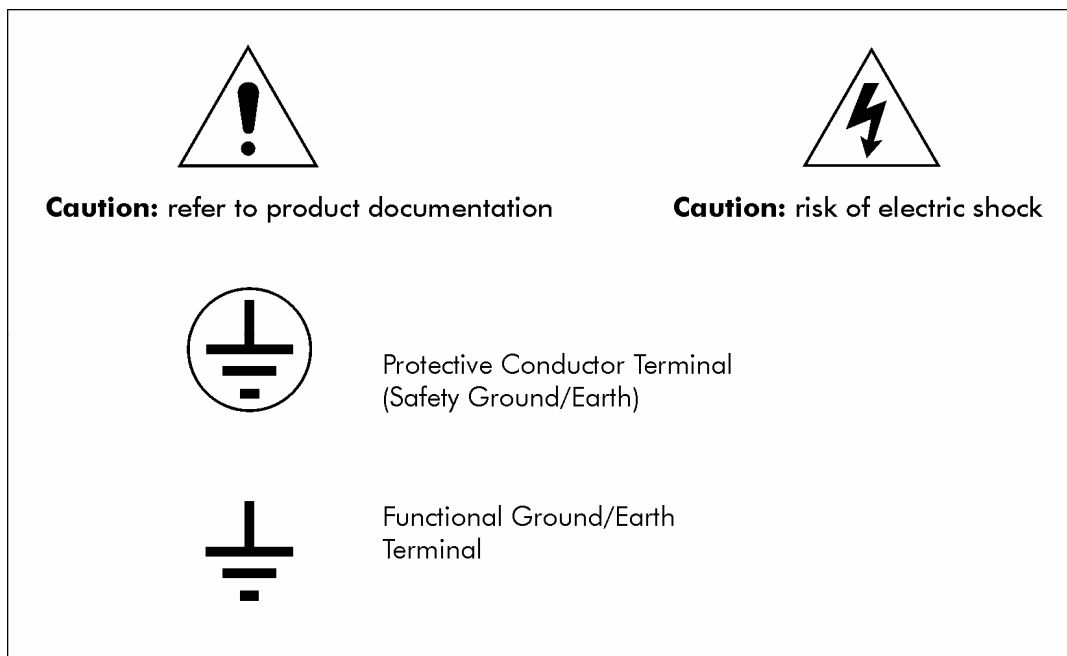

Installing, Commissioning and Servicing



Equipment connections

Personnel undertaking installation, commissioning or servicing work on this equipment should be aware of the correct working procedures to ensure safety. The product documentation should be consulted before installing, commissioning or servicing the equipment.

Terminals exposed during installation, commissioning and maintenance may present a hazardous voltage unless the equipment is electrically isolated.

If there is unlocked access to the equipment, care should be taken by all personnel to avoid electric shock or energy hazards.

Voltage and current connections should be made using insulated crimp terminations to ensure that terminal block insulation requirements are maintained for safety. To ensure that wires are correctly terminated, the correct crimp terminal and tool for the wire size should be used.

Before energizing the equipment, it must be grounded (earthed) using the protective ground (earth) terminal, or the appropriate termination of the supply plug in the case of plug connected equipment. Omitting or disconnecting the equipment ground (earth) may cause a safety hazard.

The recommended minimum ground (earth) wire size is 2.5 mm² (#12 AWG), unless otherwise stated in the technical data section of the product documentation.

Before energizing the equipment, the following should be checked:

1. Voltage rating and polarity
2. CT circuit rating and integrity of connections
3. Protective fuse rating
4. Integrity of ground (earth) connection (*where applicable*)
5. Equipment operating conditions

The equipment should be operated within the specified electrical and environmental limits.



Current transformer circuits

Do not open the secondary circuit of a live CT since the high voltage produced may be lethal to personnel and could damage insulation.



External resistors

Where external resistors are fitted to relays, these may present a risk of electric shock or burns, if touched.



Battery replacement

Where internal batteries are fitted, they should be replaced with the recommended type and be installed with the correct polarity, to avoid possible damage to the equipment.



Insulation and dielectric strength testing

Insulation testing may leave capacitors charged up to a hazardous voltage. At the end of each part of the test, the voltage should be gradually reduced to zero, to discharge capacitors, before the test leads are disconnected.



WARNING: EMISSIONS - CLASS A DEVICE (N55011)

This is a Class A industrial device. Operation of this device in a residential area may cause harmful interference, which may require the user to take adequate measures.



DECOMMISSIONING AND DISPOSAL

1. Decommissioning

The auxiliary supply circuit in the relay may include capacitors across the supply or to ground (earth). To avoid electric shock or energy hazards, after completely isolating the supplies to the relay (both poles of any dc supply), the capacitors should be safely discharged via the external terminals before decommissioning.

2. Disposal

It is recommended that incineration and disposal to watercourses is avoided. The product should be disposed of in a safe manner. Any products containing batteries should have them removed before disposal, taking precautions to avoid short circuits. Particular regulations within the country of operation may apply to the disposal of lithium batteries.

1.0 INTRODUCTION

The M870D Remote Display connects to 70 Series IEDs through one of the serial communications ports. The M870D is designed to provide a convenient way to view measurements made by the 70 Series IEDs. A maximum of 64 user-configurable measurement screens can be displayed. The instrument can be set to display a single screen continually or automatically scroll through all available screens. Additionally, the user may manually step through all available screens. All of the screens can be scrolled.

1.1 Features

- ❑ Rugged Bitronics design
- ❑ Bright LED display, 3 lines of 5 digits and a one line, 8 character alphanumeric
- ❑ Standard 4" round mounting
- ❑ Configurable RS232 or RS485 communication
- ❑ PC based configuration tool for quick setup
- ❑ Front panel service port
- ❑ Front panel Demand and Energy reset (if enabled)

1.2 Specifications

Display: 3 lines of 5 digits, Red LED, 0.56" High
1 line by 8 character alphanumeric, Red LED, 0.11" High

User Interface: 4 pushbuttons

Communication: Selectable RS232 or RS485 (4-wire), full duplex
9600, 19200, or 38400 baud
8 bit, No parity, 1 stop bit

Distance: 50 ft. (15m) RS232, 4000 ft. (1200m) RS485

Addressability: Display Addresses 1 .. 15

Power Supply Requirements:

Nominal: 24-250Vdc, 69-240Vac (50/60Hz)

Operating Range: 20-300Vdc, 55-275Vac (45-65Hz)

Burden: 11VA max, 4W max

Weight (typical) : 1.25 lbs (0.57 kg)

1.3 Environmental

Operating Temperature: -40 to 70degC

Humidity: 0-95% non-condensing

Installation Category: IC III (Distribution Level), Pollution Degree 2
(See Definitions, page 2)

Enclosure Protection: IP52 – Front Panel, IP20 – Rear
(to IEC 60529: 1989) Ratings are applicable for enclosure category 2.
(see Definitions, below)

Altitude: Up to and including 2000m above sea level

Intended Use: Indoor; Indoor/Outdoor use when mounted in an appropriately rated protective enclosure to NEMA or IP protection classifications, as required for the installation.

1.4 Physical

Connections: 3 pin removable terminal block for power inputs, accepts 26-12AWG wire (0.15-3.3mm²), or terminal lugs up to 0.325" (8.25mm) wide. Recommended minimum wire size is #18 AWG (0.5mm²). Recommended torque rating for the terminal block wire fasteners is 10 in-lbs (1.13N-m). Precautions must be taken to prevent shorting of lugs at the terminal block. A minimum distance of 0.1" (2.5mm) is recommended between un-insulated lugs to maintain insulation requirements. Standard 0.200" (5.08mm) header socket accepts other standard terminal types.

6 pin removable terminal block for communications, accepts 26-12AWG wire. Standard 0.200" (5.08mm) header socket accepts other standard terminal types. The recommended torque rating for the terminal block wire fasteners is 4.4 in-lbs (0.5N-m).

Standard 9 pin RS232 for service port

Package: 4.5" square faceplate requires 4" round cutout for mounting.

Definitions:

Enclosure Category 2:

Enclosures where no pressure difference relative to the surrounding air is present.

Installation Category (Overvoltage Category) III: Distribution Level, fixed installation, with smaller transient overvoltages than those at the primary supply level, overhead lines, cable systems, etc.

Pollution: Any degree of foreign matter, solid, liquid, or gaseous that can result in a reduction of electric strength or surface resistivity of the insulation.

Pollution Degree 2: Only non-conductive pollution occurs except that occasionally a temporary conductivity caused by condensation is to be expected.

1.5 Standards and Certifications

UL/CSA Recognized, File Number E164178
UL61010B1, 1st edition;
CAN/ CSA No. 22.2 No, 1010-1-92

If applicable, the CE mark must be prominently marked on the case label.



European Community Directive on EMC 2004/108/EC, (replaced former directive 89/336/EEC amended by 92/31/EEC, 93/68/EEC, 98/13/EC)

European Community Directive on Low Voltage 2006/95/EC (replaces former directive 73/23/EEC amended by 93/68/EEC)

Product and Generic Standards

The following generic standards were used to establish conformity:

Low Voltage (Product Safety): EN 61010-1: 2001

EMC: EN 61326-1: 2006, EN 61000-6-2: 2005, EN 61000-6-4 : 2007
(EN 50081-2: 1993 has been superseded).

Radiated Emissions Electric Field Strength

EN 55011: 2007 / A2: 2007 (supersedes EN 55011: 1998 / A1:1999)

Group 1, Class A

Frequency: 30 - 1000 MHz

AC Powerline Conducted Emissions

EN 55011: 2007 / A2: 2007 (supersedes EN 55011: 1998 / A1:1999)

Group 1, Class A

Frequency: 150 kHz – 30 MHz

Electrostatic Discharge (ESD)

EN 61000-4-2: 1995 / A1: 1998: / A2: 2001

Discharge voltage: ± 8 KV Air; ± 4 KV Contact

Immunity to Radiated Electromagnetic Energy (Radio Frequency)

EN 61000-4-3: 2006 / A1: 2008 Class III (supersedes EN 61000-4-3: 2002 & EN61000-4-3: 2002 / A1:2002; and ENV 50204: 1996, on Immunity to Radiated Electromagnetic Energy -Digital Radio Telephones, 900MHz & 1890MHz).

Frequency: 80 - 1000 MHz Amplitude: 10.0 V/m Modulation: 80% AM @ 1 kHz

Frequency: 1400 - 2000 MHz Amplitude: 3.0 V/m Modulation: 80% AM @ 1 kHz

Frequency: 2000 - 2700 MHz Amplitude: 1.0 V/m Modulation: 80% AM @ 1 kHz

Electrical Fast Transient / Burst Immunity

EN 61000-4-4: 2004 (supersedes EN 61000-4-4: 1995)

Burst Frequency: 5 kHz

Amplitude, AC Power Port ± 4 KV

Amplitude, Signal Port: ± 2 KV

Current/Voltage Surge Immunity

EN 61000-4-5: 2006 (supersedes EN 61000-4-5: 1995)

Open Circuit Voltage: 1.2 / 50 μ s

Short Circuit Current: 8 / 20 μ s

Amplitude, AC Power Port: 2 KV common mode, 1 KV differential mode

Amplitude, I/O Signal Port: 1 KV common mode

Immunity to Conducted Disturbances Induced by Radio Frequency Fields

EN 61000-4-6: 2007 (supersedes EN 61000-4-6: 1996)

Level: 3

Frequency: 150 kHz – 80 MHz

Amplitude: 10 V rms

Modulation: 80% AM @ 1 kHz

AC Supply Voltage Dips and Short Interruptions

EN 61000-4-11: 2004 (supersedes EN 61000-4-11: 1994)



2.0 INSTALLATION

WARNING - INSTALLATION AND MAINTENANCE SHOULD ONLY BE PERFORMED BY PROPERLY TRAINED OR QUALIFIED PERSONNEL.

2.1 Initial Inspection

Bitronics instruments are carefully checked and "burned in" at the factory before shipment. Damages can occur, however, so please check the instrument for shipping damage as it is unpacked. Notify Bitronics LLC immediately if any damage has occurred, and save any damaged shipping containers.



2.2 Instrument Mounting

The instrument may be mounted on a 19" Rack panel if desired. Three units will fit side by side on a standard 5.25" high panel. See Figure 2 for panel cutout dimensions. The unit should be mounted using the four #10-32 studs attached to the flanges. *Make sure that any paint or other coatings on the panel do not prevent electrical contact.*

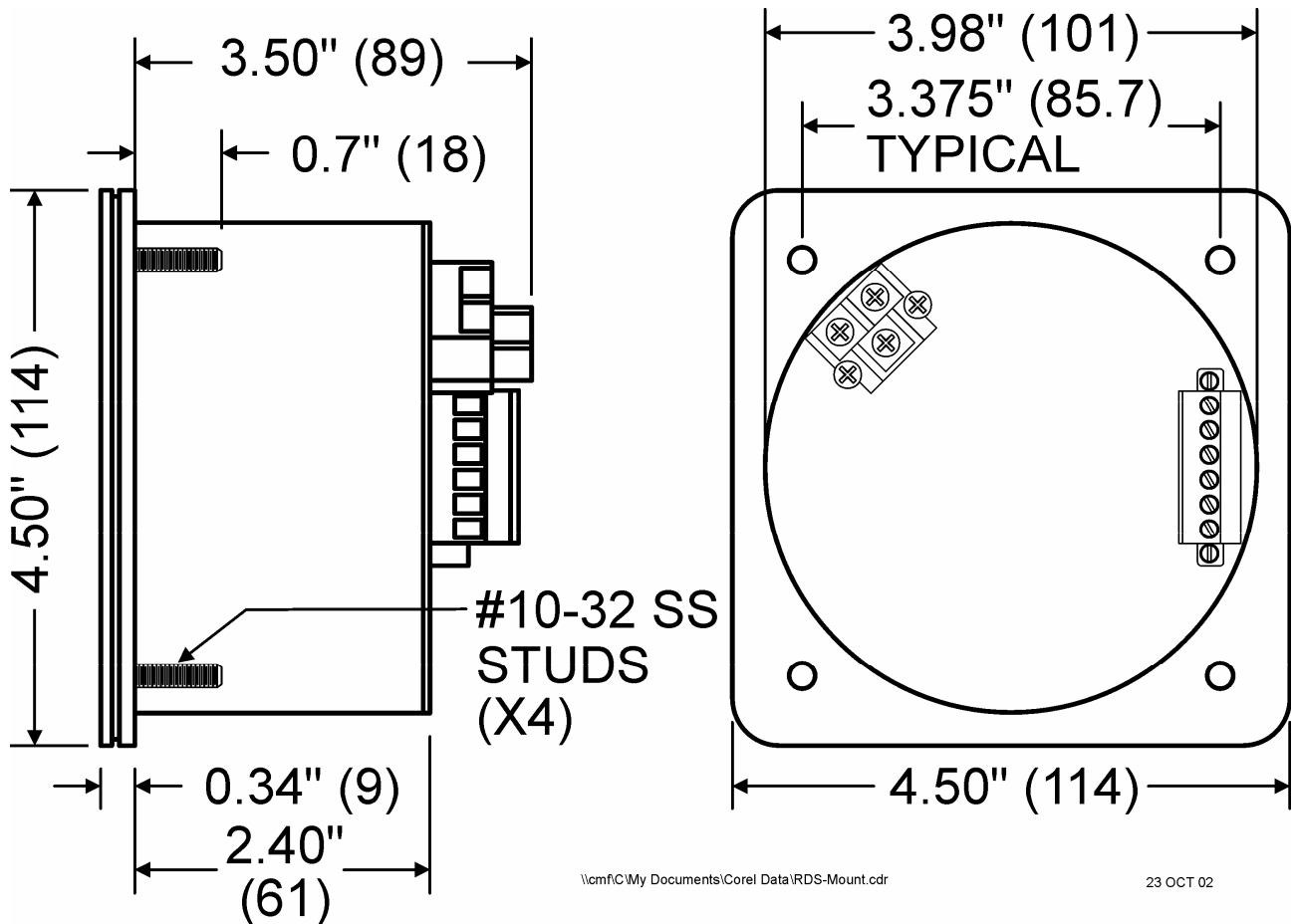

Figure 1 – Instrument Dimensions

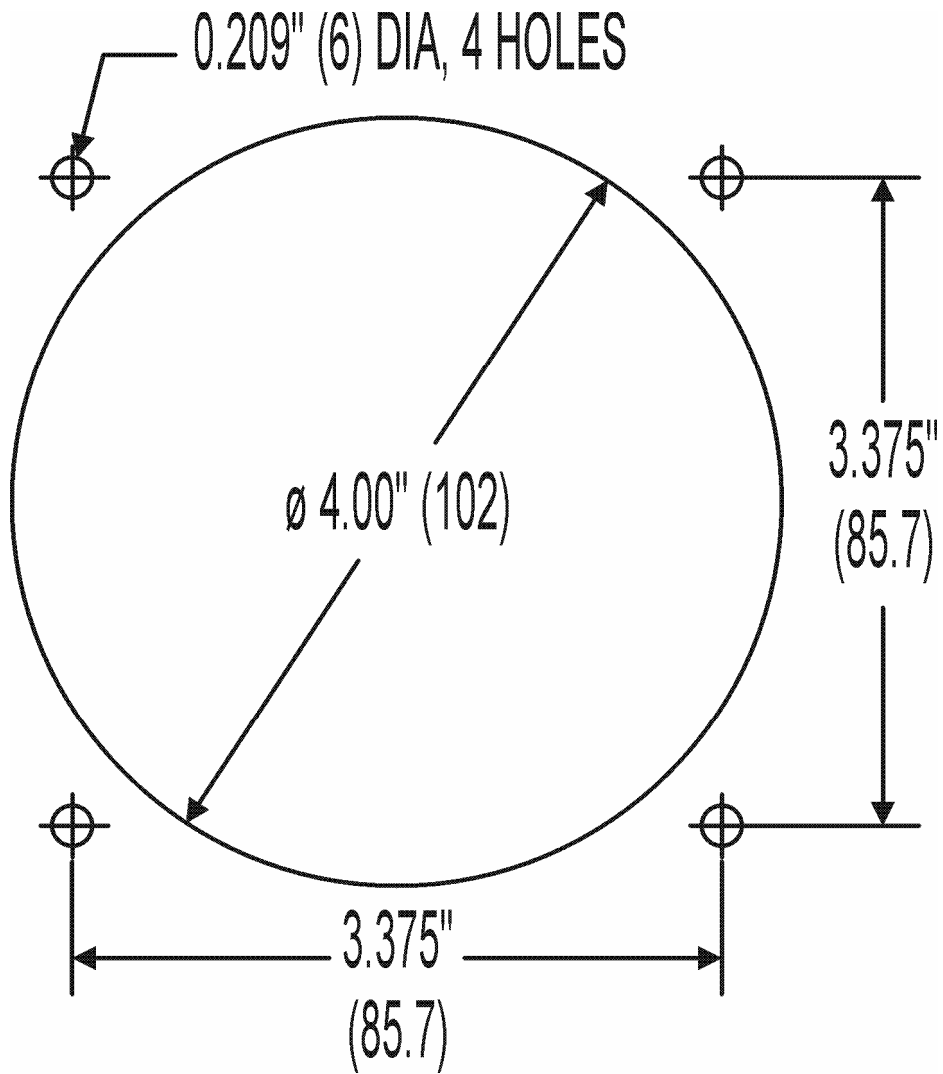

Figure 2 - Panel Cutout Dimensions



2.3 Surge Protection

Surge protection devices are incorporated into the power supply. The mounting flange is a safety ground for the instrument, and must be connected to a protective ground (earth) circuit. If the unit is powered from a VT, it is recommended that one side of the VT be grounded at the instrument following ANSI/IEEE C57.13.3-1983. See Section 2.4 for fuse recommendations.



2.4 Overcurrent Protection

To maintain the safety features of this product, a 2 Ampere time delay (T) fuse, with a minimum interrupting rating of 1500 Amperes, must be connected in series with the ungrounded/non-earthed (hot) side of the supply input prior to installation. The fuse must carry a voltage rating appropriate for the power system on which it is to be used. A UL Recognized fuse in an appropriate fuse holder should be used in order to maintain UL product approval.



2.5 Supply/Mains Disconnect

Equipment shall be provided with a Supply/Mains Disconnect that can be actuated by the operator and simultaneously open both sides of the mains input line. The disconnect should be UL recognized in order to maintain any UL product approval. **The Disconnect should be acceptable for the application and adequately rated for the equipment.**



2.6 Power Supply Connections

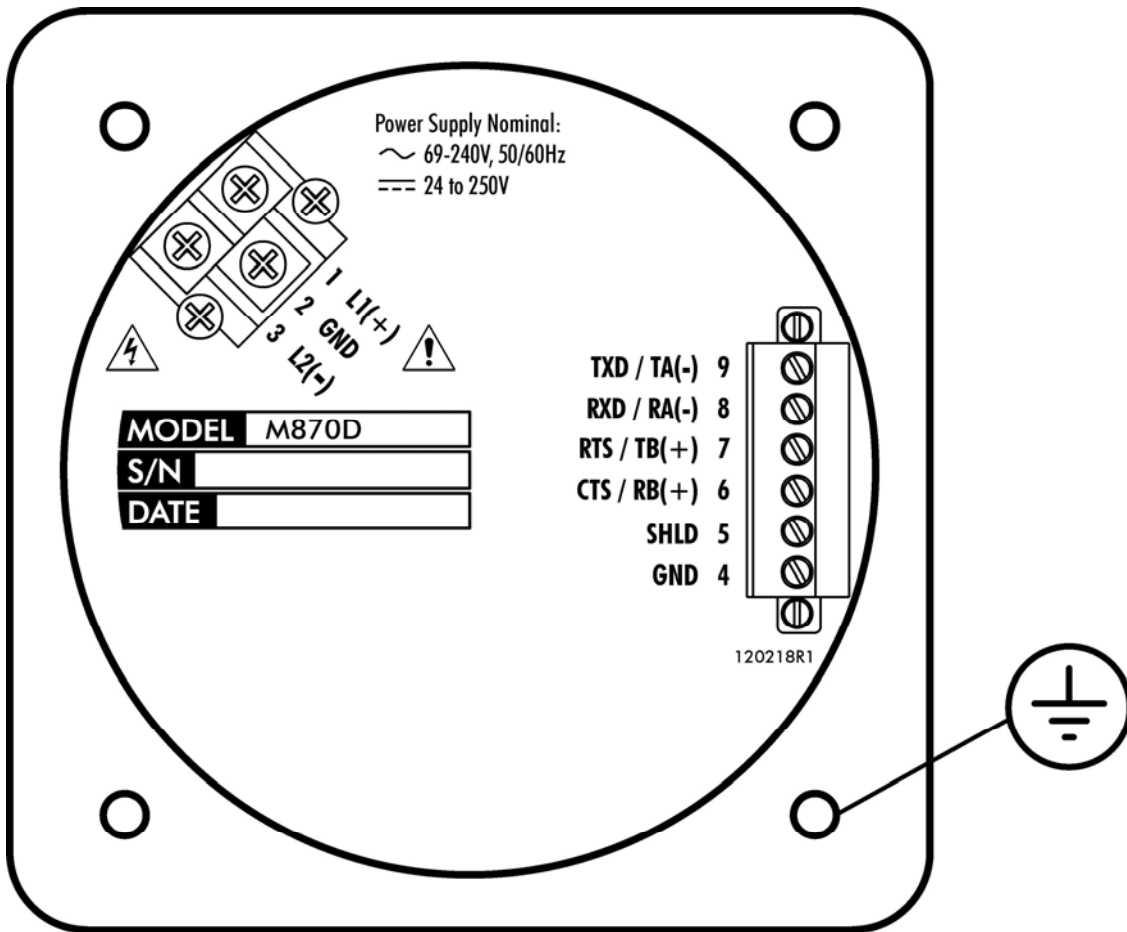

Power and ground are applied to three screws on a barrier strip on the rear of the M870D. There is one chassis ground point that **MUST** be connected to Earth Ground. This is located on the mounting flange. **Connection of the chassis ground is required, see Section 2.3.** Bitronics recommends that all grounding be performed in accordance with ANSI/IEEE C57.13.3-1983.

2.7 Cleaning

Cleaning the exterior of the instrument shall be limited to the wiping of the instrument using a soft damp cloth applicator with cleaning agents that are not alcohol based, and are non-flammable, non-explosive.

3.0 SETUP

3.1 Communications Connections

M870D RS-232 Cable Connections

M870D Rear Port to M87x DB9M

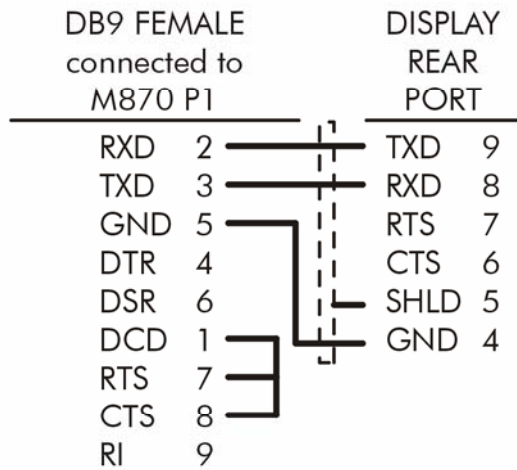

M870D DB9F Front Port to PC DB9M

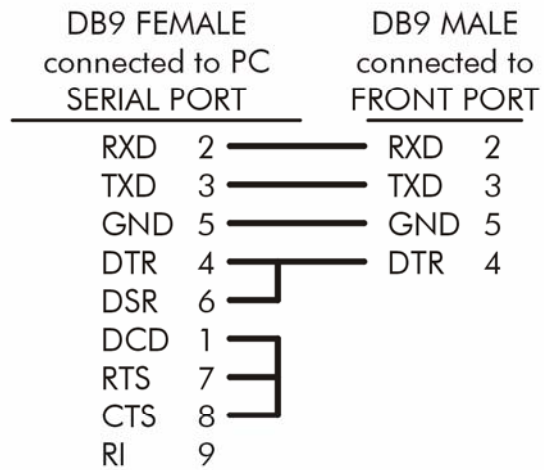

M870D Rear Port to M87x Ports

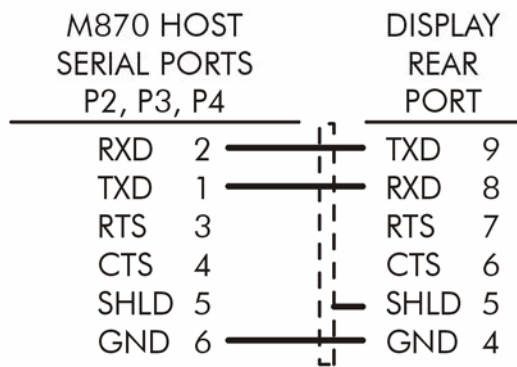

M870D DB9F Front Port to PC DB25M

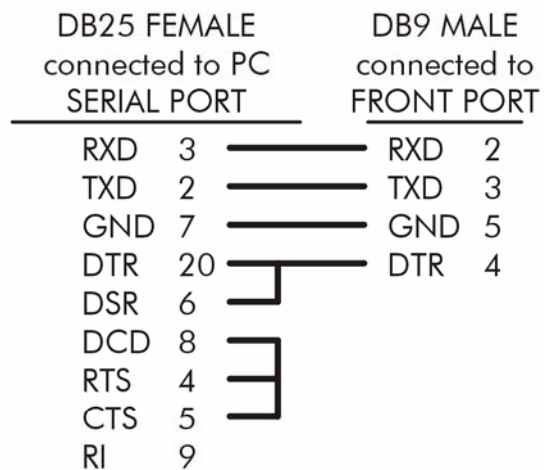

The rear port of the M870D Display and the Host port of the M87x must be set to RS-232, matching Baud rates and parity, and Display protocol.

The cable should be Belden 9842 or equivalent.
The maximum cable length for RS-232 is 50 ft (15m).

M870D RS-232 Cable Connections to the M57x

M870D Rear Port to M57x RJ11 (P1)

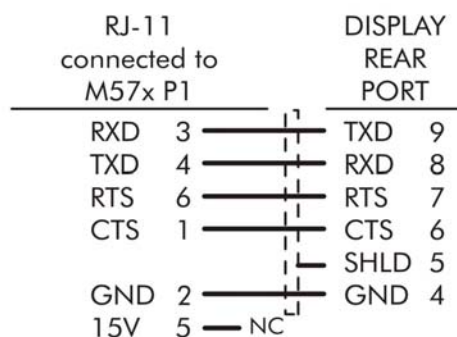

6 conductor RJ11 flat cable - RTS & CTS are required for file downloads when connecting a PC thru the M870D Front port. Otherwise, 4 conductor RJ11 flat cable will suffice for display operation.

M870D Rear Port to M57x Serial Ports

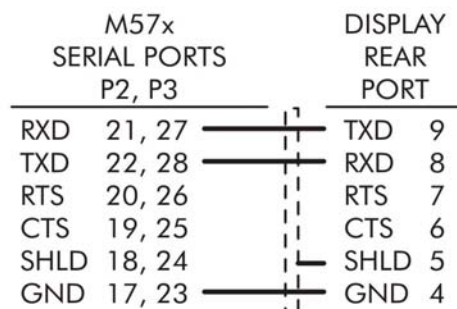

The rear port of the M870D Display and the port of the M57x must be set to RS-232, matching Baud rates and parity, and Display protocol.

The cable should be Belden 9842 or equivalent, unless otherwise specified. The maximum cable length for RS-232 is 50 ft (15m).

M57x RS-485 Cable Connections

M57x Ports to M870D Display Rear Port (4-Wire, Full Duplex) ZMODEM, Display Protocols

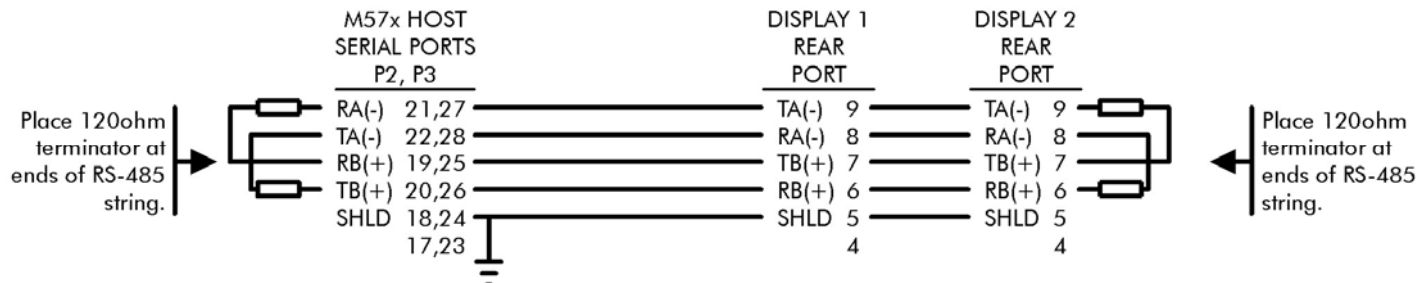

The rear port of the M870D and the Host port of the M57x must be set to RS-485, matching Baud rates and parity, and Display protocol.

The cable should be Belden 9842 or equivalent. The maximum cable length for RS-485 is 4000 ft (1200m).

M87x RS-485 Cable Connections

M87x Ports to M870D Rear Port

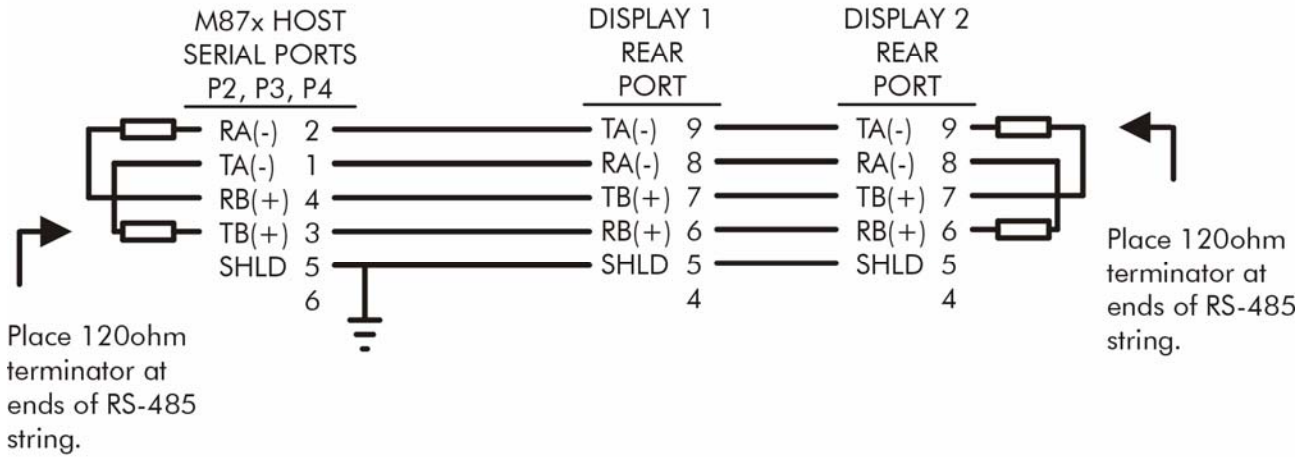

The rear port of the M870D and the Host port of the M87x must be set to RS-485, matching Baud rates and parity, and Display protocol.

The cable should be Belden 9842 or equivalent. The maximum cable length for RS-485 is 4000 ft (1200m).

3.2 Setup Mode

The M870D has three configurable parameters that must be set to match the device to which it is connected. Press the up arrow key and the right arrow key simultaneously to enter the display setup mode. The alphanumeric display will describe the selected parameter, while the digit display will show the value. Use the up and down arrow keys to scroll through the available values for that parameter. When the desired value is displayed, press the right arrow button to confirm the setting. The left arrow button is used to go to the next configurable parameter. When 'Exit' appears in the alphanumeric display, press the right arrow key to return to normal operation. The instrument will automatically return to normal operation if no keys have been pressed in approximately 20 seconds. This timeout prevents the instrument from inadvertently being left in setup mode.

The settings for Meter ID, Baud and Mode must match the corresponding settings of the M870 series instrument to which it is connected. Factory defaults for the parameters are: Meter ID = 1, Baud = 9600, Mode = 232

Parameter	Available Values
Meter ID	1 – 15
Baud	9600,19200, 38400 Baud
Mode	232, 485
Version	Displays current version information. This value cannot be modified.
Exit	Allows exiting setup mode.

Table 1 – Configurable Parameters

WARNING - THE METER ADDRESS, COMMUNICATION MODE, AND BAUD RATE PARAMETERS ARE STORED IN NON-VOLATILE MEMORY. THIS MEMORY STORAGE HAS A 1,000,000 CYCLE ENDURANCE RATING. (PARAMETERS CAN BE CHANGED 1,000,000 TIMES).

Note: Instruments produced prior to July, 2002 will display a 'Remove Power!' message when the hardware setup has been changed. If this message is displayed, remove the input power to the instrument for a few seconds and then reapply power. The instrument will go through its normal boot sequence and the new settings will take effect.

3.3 Measurement Screens

Measurements that are shown on the M870D are setup using the Windows® based 70 Series Configurator. There are two folders in the Communication section, which must be configured before the M870D can be used. The first folder is used to setup the Port Assignments, as shown in Figure 3. Set the protocol of the port to which the Remote Display is connected to Zmodem/Display/Log. Set the Media, Parity, and Baud settings as required. The RxD to TxD parameter can be set to zero and the Run Display box must be checked. In this example, Port 1 is set to run the display.

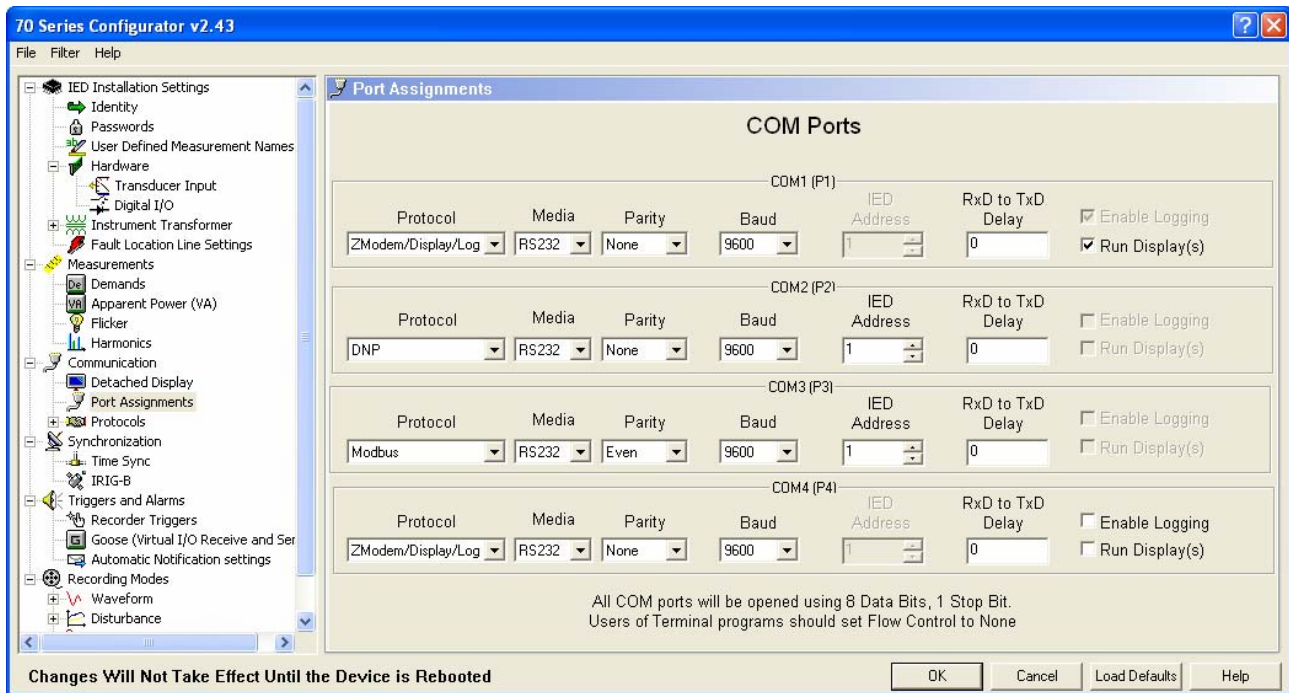

Figure 3 – Configurator Communication/Port Assignments Folder

The Detached Display Folder must now be set up to show the proper measurements. Figure 4 shows the layout of this folder.

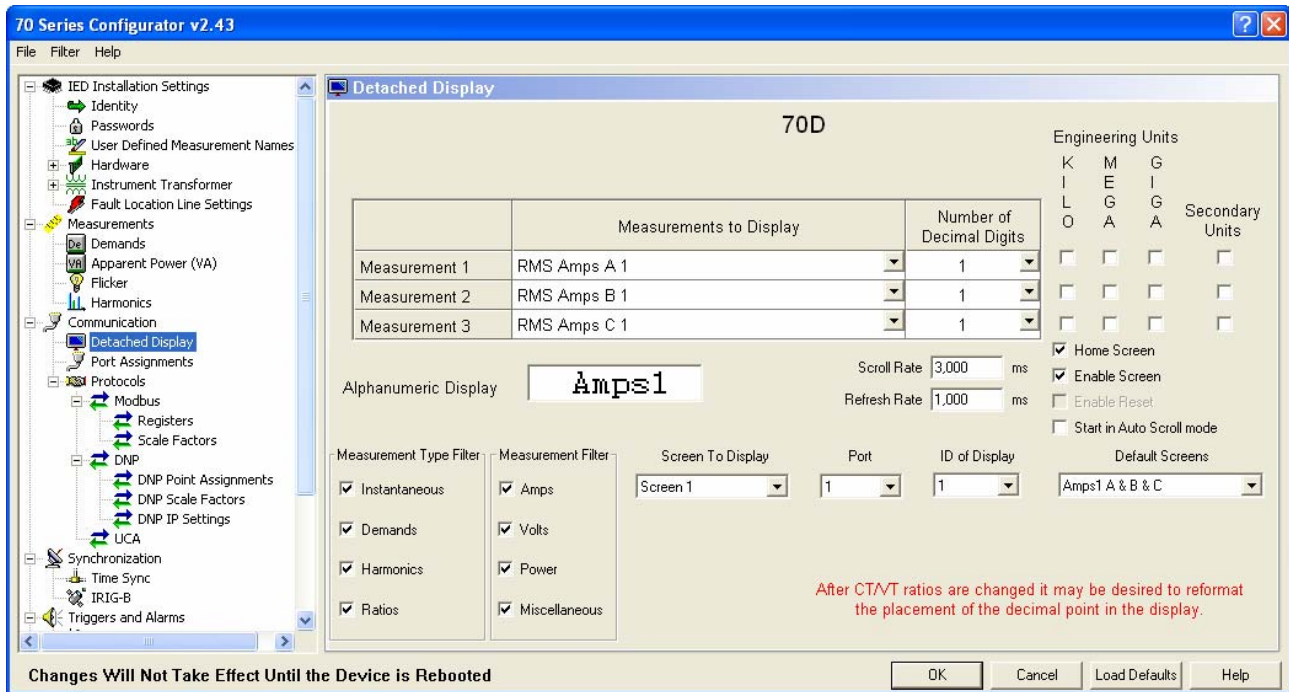

Figure 4 – Configurator Communication/Detached Display Folder

Screens are defined by choosing measurements from a drop down list and then specifying the resolution, scale factor, and text information for the screen. Up to 64 screens can be defined for each display. Multiple displays can be attached to a single 70 Series IED, but the total number of available screens is limited to 64. Each screen can be assigned to a particular 70 Series IED serial port and remote display address. The screen definitions are stored in the 70 Series IED and not in the Remote Display.

Demand and Energy values may be reset from the front panel if this option is selected in the configuration software. If this option is chosen, the displayed values will be reset when the right two buttons on the front panel are depressed simultaneously.

Please refer to the online help in the 70 Series Configurator for additional information.

Note: The Meter ID of the M870D must match the "ID of Display" value.

3.4 Operation

3.4.1 Overview

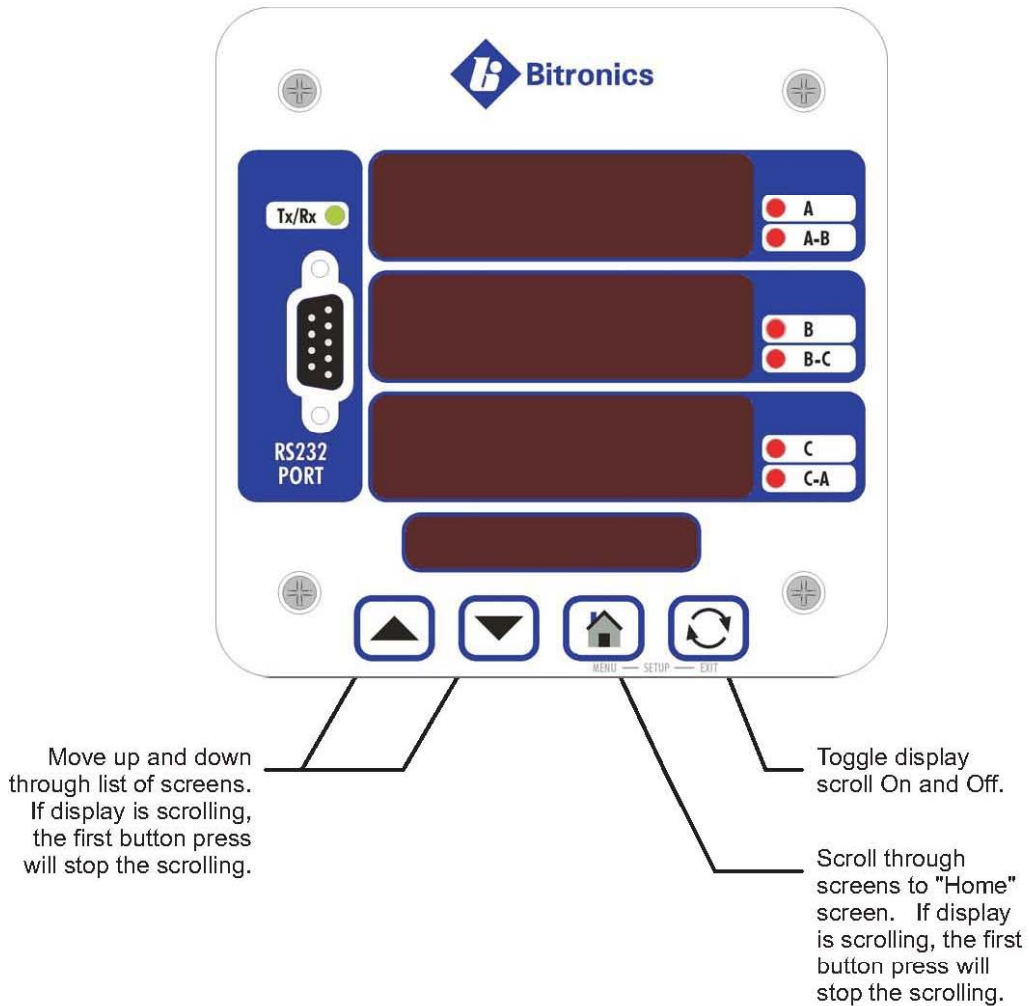

1. Pressing any button when the display is scrolling will end the scroll.
2. Connect to the front panel RS232 port with a "straight through" cable. Do NOT use a "null-modem" cable.

3.4.2 Keypad

Measurements screens may be stepped through manually by pushing the up and down arrow keys. Pushing the right arrow key turns the scroll function off and on. When the scroll function is activated, the measurement screens will automatically step through the user-defined screens. Pressing the left arrow key will initiate a single pass automatic scroll through the measurements, stopping on the Home screen. The scroll rate and home screen are setup in the 70 Series Configurator software.

Button	Function
Up Arrow	Next measurement/value
Down Arrow	Previous measurement/value
Left Arrow	Scroll to designated home screen
Right Arrow	Toggle Auto Scroll On/Off
Combination Up and Right Arrow keys	Enter Setup Mode
Combination Down and Left Arrow keys	Enter Firmware Upgrade Mode
Combination Left and Right Arrow Keys	Reset Displayed Value (if enabled)

Table 2 – Pushbutton Functions

3.4.3 Tx/Rx LED

The Tx/Rx LED located on the front panel above the RS232 port lights whenever activity is detected on either of the instruments communications ports.

3.5 RS232 Service Port

The front panel port acts as an extension to the 70 Series IED service port (P1). This port can be connected to a terminal or a PC running a terminal emulator program, such as Hyperterminal. Through this connection it is possible to view log messages, set the date/time, and transfer files. Refer to the M87x User Manual for further information.

When transferring files using the front panel service port the display is not updated. A message indicating a file transfer is in progress is displayed at this time.

When connecting the Service Port to a PC, a straight through cable, either 9-pin to 9-pin or 9-pin to 25-pin, is required. A null modem cable is not required.

4.0 TROUBLESHOOTING

4.1 Error/Informational Messages

Message	Explanation	Action
No Comm	No valid messages are being received by the display.	Check cable connections and setup parameters on the Remote Display and M870 transducer.
Config Error	There was an error in the stored configuration parameters. The default parameters have been restored.	Enter setup mode and check that all parameters are set properly. If error persists contact the factory.
Remove Power!	Instrument configuration has been changed or new code has been downloaded. Applies only to devices manufactured prior to July, 2002.	Remove power to the instrument for a few seconds and then reapply.

5.0 FIRMWARE UPGRADES

The M870D is field upgradable. Please refer to specific instructions provided with new firmware.



Measurement Products

Change of Company Name / Ownership

Product Technical Compliance, Type Test Certificates & Declarations of Conformity

Areva's Transmission & Distribution Measurement Unit based in Bethlehem Pennsylvania, USA was purchased by NovaTech LLC on July 1, 2008, and henceforth continues to operate as an affiliate of NovaTech LLC under the company name of:

Bitronics LLC
261 Broadhead Road
Bethlehem, PA 18017, USA

The change of ownership and company name at the Bethlehem location has resulted in the Measurement organization and its operations remaining substantially the same. In regards to product technical compliance and performance claims, the following points indicate business continues as usual for the Bethlehem site:

- Technical Staff have been retained.
- Instruments will continue to be designed in Bethlehem.
- Production processes are unchanged.
- Measurement products are retained.
- A revision on product labels to indicate Bitronics as the company name shall be implemented.
- A strategic partnership agreement has been entered with Areva T&D, such that Bitronics LLC will manufacture products to be globally distributed under the AREVA T&D MICOM brand. A revision to product labels is anticipated.

Continuing to the subject addressing some of the necessary technical documentation, which is relied upon, the intent is to utilize existing product Type Test Certificates and Declarations of Conformity. The change of company name will not be implemented retroactively on these types of documents. Instead the change of company name to Bitronics will appear on new documents moving forward, that are created after July 1, 2008. Existing product approvals will be relied upon.

Andre Wagner – R&D Manager

Date: Oct 2, 2008

Issue 1



EC Declaration of Conformity

We, the undersigned:

Manufacturer:	Bitronics LLC 261 Brodhead Road Bethlehem, PA 18017-8698 USA T +610.997.5100 F +610.997.5450 E bitronics@novatechps.com	Authorized Representative in the European Union:	NovaTech Europe BVBA Kontichsesteenweg 71 2630 Aartselaar Belgium T +32.3.458.0807 F +32.3.458.1817 E info.europe@novatechps.com
----------------------	--	---	---

hereby declare that the following product(s) :

Product type :	M870D Display
Description :	70 Series Remote Display
Models :	M870D

Conform(s) with the protection requirements of the following directive(s) :

1. European Community Directive on EMC 2004/108/EC, 2. European Community Directive on Low Voltage 2006/95/EC,

The following route(s) were used to establish conformity :

1. **2004/108/EC:** In accordance with Article 7 Annex II (internal production control supported by a Technical File).

Technical File No. :	TF B002
Date Revised :	26-March-2009 (original issue dated 10-July-2003)
Conformity Assessment Body : (C.A.B.)	Underwriters Laboratories, Inc., Melville Division 1285 Walt Whitman Road, Melville, NY 11747-3081 USA
Compliance Certificate Test Report:	E164178, 02ME10552, M870D, MA/EMC; E164178, 1001052984, M87x, M57x, M870D, M570Dx EMC 09CA09082

2. **2006/95/EC:** Self Certification supported by a Technical File.

Technical File No. :	TF B002
Date Revised :	26-March-2009 (original issue dated 10-July-2003)

Reference Number : DOC B002 **Issue :** E

Date of issue : 13-April-2009

The following standards were used for reference and to establish conformity :

EN 61010-1: 2001 UL 61010B-1	Safety requirements for electrical equipment for measurement, control, and laboratory use. Part 1: General requirements
EN 61326-1: 2006	Electrical Equipment for measurement, control and laboratory use – EMC requirements
EN 61000-6-4: 2007	Electromagnetic compatibility: Generic emission standard – Industrial environment.
EN 61000-6-2: 2005	Electromagnetic compatibility (EMC) Part 6-2: Generic standards - Immunity for Industrial environments.
EN 55011: 2007 / A2: 2007, Group 1 Class A	Radiated Emissions Electric Field Strength, AC Powerline Conducted Emissions
EN 61000-4-2: 1995 / A1:1998 / A2:2001	Electrostatic Discharge (ESD)
EN 61000-4-3: 2006 / A1:2008, Class III	Immunity to Radiated Electromagnetic Energy (Radio Frequency)
EN 61000-4-4: 2004	Electrical Fast Transient / Burst Immunity
EN 61000-4-5: 2006	Surge Immunity
EN 61000-4-6: 2007, Level 3	Immunity to Conducted Disturbances Induced by Radio Frequency Fields
EN 61000-4-11: 2004	AC Supply Voltage Dips and Short Interruptions

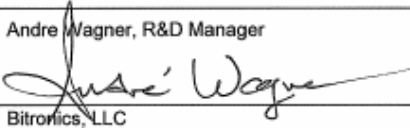
Signed on behalf of the Company :	Andre Wagner, R&D Manager
	 Bitronics, LLC

CE Marking Year 2003, 2009

Reference Number : DOC B002
Date of issue : 13-April-2009

Issue : E

Form BIDOC_B back

Revision	Date	Changes	By
A	01/30/2009	Update Bitronics Name, Logo	E. DeMicco
B	05/01/09	Updated logos and cover page	MarCom
C	9/22/09	Updated Section 1.5 to reflect current standards, updated Declaration of Conformity	RAF/EJD



Bitronics LLC, 261 Brodhead Road, Bethlehem, PA. 18017
(610) 997-5100 Fax (610) 997-5450
www.novatechweb.com/bitronics