

INSTRUCTIONS FOR USE

VIP Panel DROPSA SpA

In accordance with point 1.7.4, to I, Dir 98/37 CE

Sections:

- 0.0 INTRODUCTION
 - 1.0 DESCRIPTION OF THE EQUIPMENT
 - 2.0 TECHNICAL SPECIFICATIONS
 - 3.0 CORRECT USE
 - 4.0 INSTRUCTIONS FOR ORDERING
- DECLARATION OF CONFORMITY



Catalogue P/N C2019IE - Wk 35/04

Registered name	DROPSA SpA
Address	via Croce 1, 20090 Vimodrone (MI), Italy
Model	VIP
Year of manufacture	1999
Marking	CE

0.0 INTRODUCTION

This user's and maintenance manual refers to the **VIP panel**, used for controlling and monitoring small and medium sized lubrication systems.

It is recommended that this manual is carefully kept in good condition and is always available to persons requiring to consult it.

To request further copies, updates or clarification with respect to this manual contact the Engineering Department at Dropsa SpA.

The use of the panel referred to in this manual must be entrusted to qualified personnel with a knowledge of hydraulics and electrical systems.

The manufacturer reserves the right to update the product and/or the user's manual without the obligation to revise previous versions. It is however, possible to contact the Engineering Department for the latest revision in use.

The equipment should be carefully checked immediately on receipt and in the event of any discrepancy or complaint the Dropsa SpA Sales Department should be contacted without delay.

DROPSA S.p.A. declines to accept any responsibility for injuries to persons or damage to property in the event of the non-observance of the information presented in this manual.

Any modification to component parts of the system or the different destination of use of this system or its parts without prior written authorisation from DROPSA S.p.A. will absolve the latter from any responsibility for injury or damage to persons and/or property and will release them from all obligations arising from the guarantee.

Instructions for the correct ordering of the required model, and a list of importers, are given in Section 4

1.0 DESCRIPTION OF THE VIP PANEL

This high performance low cost equipment has been designed for the controlling and monitoring of the majority of small and medium sized lubrication systems.

The configuration parameters are electronically memorised in two separate menus eliminating the problem of having to pre-set DIP switches or terminals.

The operator's menu is utilised to set the work and pause timings.

The machine/system menu is used to configure the type of pump and the type of lubrication system to which the panel is connected.

The panel is also able to be remotely programmed; it has a scanner located under the remote control symbol on the face of the panel.

When used with a Transmitter module, the desired configuration can be loaded and memorised by simply positioning it over the symbol and pressing the Enter data key.

This results in a big saving of time when being used on a production line by eliminating the need to configure each separate control device individually.

Technical and general characteristics:

Characteristic	VIP
Power supply	110/120/220/240V 40/60 Hz (Part N° 1639077) 24 VDC – 24 VAC (Part N° 1639076) 12 VDC (Part N° 1639094) 24V (Part N° 1639163) 110/220V (Part N° 1639164)
Absorbed power	20 Watts
Temperature of use	-5 °C ÷ + 55 °C (+23°F ÷ 131°F)

N.B. the output voltage is the same as the input

<i>Input signals</i>	Max 12V Pressure switch normally open Microcontact or magnetic reed contact Proximity (NPN/PNP) <ul style="list-style-type: none"> • Level control: Max 12V Contact closes at minimum level • Impulse counter: Max. count frequency 10 Hz at 25%
<i>Output signals</i>	Pump command contact: feed depending on connected voltage. <ul style="list-style-type: none"> • Remote alarm contact NO (NC for 1639101) Voltage-Free contact, 250V maximum, 1 amp • Step optional for use of external alarm ONLY FOR VERSIONS 1639163, 1639164: Terminal 7 and 8 are a normally open, voltage-free switch, available as switching device for an external alarm circuit. Connect fused (+) power supply (not supplied) to terminal 8. Connect terminal 7 to external alarm. Ground external alarm to complete circuit.
<i>Case</i>	<ul style="list-style-type: none"> • External dimensions: 132 X 132 X 160 mm • Fixing: 95 X 95 mm • Protection class: IP54

Integrated VIP control

Max. running time	99 minutes 59 seconds with increments of 10 seconds
Max. pause time	99 hours 59 minutes (increments of 1 minute)
Max. pause counter	Up to 1-2500 impulses (increments of 10 impulses)
Suspension function	Allows the user to interrupt the control functioning
Infra red receiver (accessory)	For remote control regulation





The following table shows a summary of the system menu

Setting of the system operating menu

This menu is utilised to configure the type of pump and the type of lubrication system interconnected with the panel.

To access this Menu press the \downarrow \uparrow simultaneously for at least two seconds.

To directly access the modify Times Setting press MODE for at least two seconds

Parameters	Display	Description	Operation	
Pump selection	*PNU	With a single action pneumatic pump with a cycle repetition every 4 seconds.		Press \uparrow to select between the two values.
	*ELE	The pump is commanded by a continuous signal.		
				Press MODE to change function
Select SEP lubrication system	*SEP	To control systems with progressive dosers.		Press \uparrow to select between the values.
	PSI	To control systems with pressure switch.		
	CLOC	To command pause/work systems without control.		
				Press MODE to change function
Select pause function	*TI	Pause with time functioning.		Press \uparrow to select between the two values.
	*CYCL	Pause with impulse functioning.		

The Functioning Menu is utilised to regulate the “PUMP OP” cycle time and to regulate the pause functions.

To access the Operator Menu press the MODE key for two seconds;

function accepted by the blinking of the “PUMP ON” LED. Proceed in the sequence shown in the table.

*** These functionalities are not available for versions 1639163 and 1639164.**

Parameters	Display	Description	Operation	
Cycle time	MM : SS	"pump on" blinking	↑ ↓	The desired time is entered by pressing the ↑ ↓ keys
		To access the function	MODE	Press the MODE key for at least two seconds.
Pause time	HH : MM	Indicates the interval between one lubrication cycle and the next	↑ ↓	Use the ↑ ↓ to regulate the setting.
Impulse counter	*13 : 20	Indicates the number of impulses between the lubrication cycles.		
		Return to initial menu	MODE	Press the MODE key for at least two seconds.

* This functionality is not available for versions 1639163, 1639164.

2.0 TECHNICAL SPECIFICATIONS

2.1 Fixing and dimensions

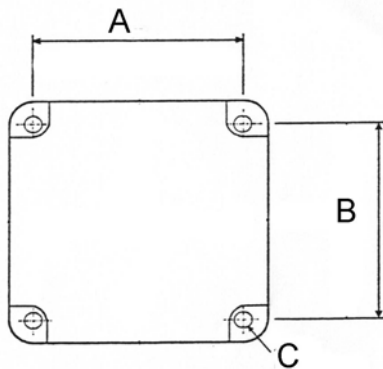

Part N°	A	B	C
1639076-77-94	95 mm (3.7 in.)	95mm (3.7 in.)	Ø 3.5 mm (Ø 0.14 in.)
1639081-87-89	153 mm (6 in.)	222 mm (8.7 in.)	Ø 4 mm (Ø 0.15 in.)
1639080-84	111.5 mm (4.4 in.)	111.5 mm (4.4 in.)	Ø 4 mm (Ø 0.15 in.)
3056205	210 mm (8.2 in.)	160 mm (6.3 in.)	Ø 4 mm (Ø 0.15 in.)
1639163	132 mm	132	Ø 3.5 mm.
1639164	(5.2 in.)	(5.2 in.)	(Ø 0.14 in.)

2.2 Electrical system – Technical data

Alarms	Control	Minimum	With function
	Type	Level	

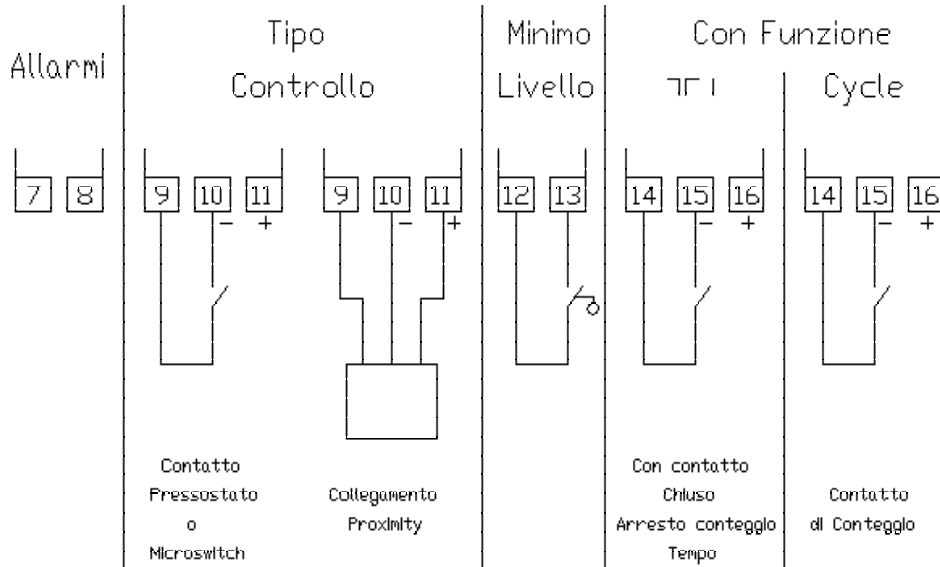

Pressure switch or microswitch contact	Proximity connection		With contact closed Time counting halted	Counting contact
--	----------------------	--	--	------------------

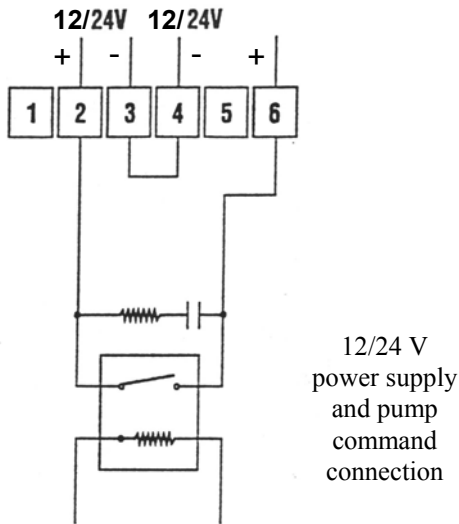

COLLEGAMENTO ALIMENTAZIONE 24V E COMANDO POMPA

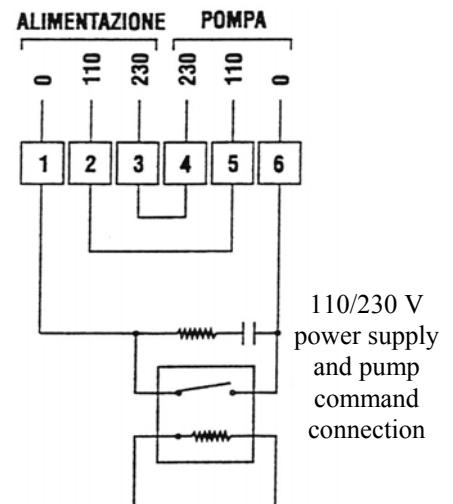

COLLEGAMENTO ALIMENTAZIONE 110/230V E COMANDO POMPA

3.0 CORRECT USE

3.1 Putting into service

Damage to the power supply cable and housing could result in contact with high voltage live parts and hence be a danger to life:

- ◆ carefully check the integrity of the power supply cable and the unit before use;
- ◆ In the event of there being damage to the power supply cable or the unit, **DO NOT** put the system into service!;
- ◆ Replace the damaged power supply cable with a new one;
- ◆ The unit should be opened and repaired **ONLY** by qualified personnel;
- ◆ In order to prevent dangers of electric shock due to direct or indirect contact with live parts it is necessary that the electrical power supply line is adequately protected by a suitable differential magneto-thermal circuit breaker with an intervention threshold of 0.03 Ampere and a max. operating time of 1 second.

The breaking capacity of the circuit breaker must be = 4 kA and the nominal current $I_n = \leq 1 A$.

- ◆ The panel **MUST NOT** be utilised in environments which are particularly aggressive or explosive/inflammable if not prepared for this purpose beforehand by the supplier.
- ◆ Procedure for checking the functioning of the equipment; each time the panel is switched on it performs a self-diagnosis on the functions and displays any alarms. (see Diagnostic table).

Alarm Codes:

Alarm code	Description	Corrective Action
AO1	No parameters set	Set the parameters of the system. See Setup on pages 3.
AO2	Level Lubrication low	Add lubricant to the supply container. NOTE: This alarm requires that your system has a low-level switch installed.
*AO3	The commutation contact in the progressive system (SEP) has not executed the cycle in the time set	
AO4 (PSI mode only)	The system pressure was already high before the start of the cycle.	Check pressure switch and replace if necessary. Check to see if system vents properly.
AO5 (PSI mode only)	PSI mode: The system did not achieve pressure during the specified cycles times. 1. Pump ON setting for the system is too short. 2. Out of lubricant. 3. Broken supply line. 4. Injector malfunction. 5. Vent valve malfunction.	Check for and correct lubricant leakage from any loose fittings or from the pump. Adjust setting as appropriate. See Time Menu on page 4. Fill reservoir. Fix or replace. Replace. Fix or replace.

*** This alarm is not available for versions 1639163, 1639164.**

Troubleshooting:

Description	Problem	Solution
Timer fails to activate solenoid	No power supplied to solenoid. Solenoid faulty. Timer faulty. Low Level alarm.	Power light off: timer is not receiving power. Verify connections and verify power supply. Power light on: verify solenoid connections Replace solenoid. Replace timer. Refill reservoir.
Pressure switch fails to shut down system	Pressure switch incorrectly wired. Pressure switch faulty. Timer faulty	Verify proper connections. Replace pressure switch. Replace timer.

3.2 Use

1. verify the settings made;
2. press the start button of the machine to which the VIP is connected;
3. verify the starting of the pump;
4. verify the adequate lubrication of the machine (if doubt exists as to the correct functioning consult the Engineering Department of Dropsa SpA to request test procedures).

3.2.1 Use of the programmable power supply for recharging the remote control

The VIP/SMART remote control has inside a rechargeable battery to permit it to be used autonomously. Supplied with the remote control Kit is a programmable power supply unit and a short connection cable.

To recharge the remote control, proceed as follows:

- 1) Turn the power supply over so that the 220V plug is uppermost. Take note of the raised “+” and “-” signs. On the same side is the socket of the connection cable.
- 2) Connect the connection cable to the power supply (using the small plug) paying attention to the polarity; there are also raised “+” and “-” signs on the plug which must be matched with those on the power supply unit.
- 3) Turn the unit so that the rotary output voltage selector is visible. Using a screwdriver or a coin, rotate the selector to position it on “6” – the charging time is 15 hours.
- 4) Connect the other end of the connection cable to the remote control (the socket is on the side of the remote control) and connect the power supply unit to a 220V mains supply socket, maintaining it under charge as previously described.

WARNING: While the remote control is being charged it is disabled, i.e. it will not function. To enable it to function, the connection cable must be detached. Do not leave the unit on charge for more than 15/16 hours, or the internal battery could be damaged.

3.3 Transport and storage

Transport and storage is effected in a cardboard package.

No particular precautions are required except as noted on the package itself. handling can be effected by one person.

! Lift the unit with taking account of the right way up indicated on the cardboard carton

! The machine components can withstand temperatures, during storage, from -20 to +50°C; however, in order to avoid damage, starting of the machine should occur at a minimum temperature of -5°C.

3.4 Assembly/Disassembly

No assembly operations are envisaged.

For wall mounting ensure adequate space is available (as shown in the installation diagram) to avoid abnormal postures and possible impacts; four fixing holes are provided as shown in Section 2.

During disassembly operations ensure the power supply is disconnected.

Where the panel is to be scrapped, do not dispose of potentially polluting parts in the environment, following local regulations for their correct disposal.

At the time of the machine being scrapped it is necessary to remove and destroy the identification plate and all other relative documents.

3.5 Regulation

The steps to modify the settings of the equipment are shown in Section 1.

VIP Panel (version with control card)

To regulate all the parameters start the pump and press $\uparrow + \downarrow$ for 2 seconds. Then follow the instructions shown in

the summary table of the system menu.

To modify only the “pump on” and “pause” values, press the MODE key for 2 seconds.

Remote control

To modify the control parameters using the infrared:

- a) check that the panel is functioning
- b) position the programmer on the remote control symbol and press “transmit” on the programmer.

The control emits a series of flashes per approx. 5 seconds to confirm that the data has been correctly received.

3.6 Maintenance

! *Locate the machine in conditions which facilitate easy access.*

The VIP device does not require any maintenance.

3.7 Repair

No repair operations are envisaged; in case of malfunctioning contact the Engineering Department of DROPSA S.p.A.

3.8 Dangers present in use

The verification of conformity with the relevant EN 60204-1 electrical safety requirements and regulations is effected by means of the compilation of a check list which has been pre-prepared and is contained in the *technical file*.

4.0 INSTRUCTIONS FOR ORDERING AND LIST OF DISTRIBUTORS

VERSIONS

Part number	Description
1639076	VIP 24V Box version
1639077	VIP 110/230V Box version
1639080	VIP 24 DC Version with panel mounted
1639084	VIP 110/230V Version with panel mounted
1639088	Remote transmission module
1639081	VIP 220V Single phase in steel case
1639087	VIP 380V – 50 Hz 3-phase in steel case
1639089	VIP 500V – 50 Hz 3-phase in steel case
1639094	VIP 12V Box version
1639097	VIP 220V single phase/3-phase
3056205	VIP 115/230V – 50/60 Hz with 50 W power and 24 V transformer
1639163	VIP 24V
1639164	VIP 110/220V

Replacement parts : No replacement parts are provided. Refer any repair requirements to manufacturer.

CE Declaration Of Conformity

Manufacturer: DROPSA SpA Company Via Croce, 1 - 20090 Vimodrone (MI), Italy Address +39 02 250791 Telephone
--

It is certified that:

The machine: VIP Panel Ver. 076 – 077 – 080 – 084 – 088 – 081 – 087 – 089 – 097 – 163 -164 - 3056205

- * is manufactured in conformity with the DIRECTIVE OF THE COUNCIL OF THE EUROPEAN COMMUNITY concerning the harmonisation of member states legislation relative to Low Voltage and Electromagnetic compatibility (EMC (89/336/CEE) and BT (73/23/CEE) and relative amendments.
- * is manufactured in accordance with the following standards and harmonised technical specifications:
EN 292/1, EN 292/2, EN 50081-2, EN 50082-2, CEI EN 60204-1.

Technical Manager

Ing. Walter Divisi

Product Manager

Name

DROPSA SpA - Vimodrone (MI) - Italy

Company



January 1999

Signature

Date

DROPSA SPA DISTRIBUTORS

ITALY

Dropsa SpA
t.(+39) 02-250791
f.(+39) 02-25079767

U.S.A.

Dropsa Corporation
t.(+1) 586-566-1540
f.(+1) 586-566-1541

BRAZIL

Dropsa
t.(+55) 011-563-10007
f.(+55) 011-563-19408

AUSTRALIA

Dropsa Australia Ltd.
t.(+61) 02-9938-6644
f.(+61) 02-9938-6611

SPAIN

Polydrop, S.A.
t.(+34) 93-260-22-50
f.(+34) 93-260-22-51

U.K.

Dropsa (UK) Ltd
t.(+44) 01784-431177
f.(+44) 01784-438598

GERMANY

Dropsa GmbH
t.(+49) 0211-394-011
f.(+49) 0211-394-013

FRANCE

Dropsa Ame
t.(+33) 01-3993-0033
f.(+33) 01-3986-2636