



User Manual

GRI-975Li



TABLE OF CONTENTS

INTRODUCTION	3
BASIC SET-UP	4
TURNING ON YOUR GRI-975LI	6
FREE WHEEL MODE	7
PRECAUTIONS	7
BATTERY MAINTENANCE	8
ALIGNMENT SYSTEM	10
FOR WARRANTY, SPARE PARTS AND ACCESSORIES:	12

INTRODUCTION

Thank you for purchasing the Cart Tek GRI-975Li golf trolley. Your Cart Tek trolley cart was thoroughly quality control checked and road tested before being shipped to your address. We do everything possible to assure that your trolley is in perfect working order upon arrival. Should you have any issues or questions about the performance of your trolley, please contact us at sales@carttek.com or 541-633-4308.

Please read this manual carefully before use. After unpacking please keep the carton and all internal sections in safe storage. In the unlikely possibility that you need to return the whole unit due to a defective component, you will need to repack the unit in the original manner to ensure safe and secure transit. Check that all components are included in the package –

- Main Trolley frame
- Drive wheels
- Battery, complete with battery bag and extension cable
- Battery charger
- Accessories
- User Manual

Please note that our design and manufacturing policy is aimed at continuous improvement, this can result in changes without notice to the specifications contained in our websites and in this manual.

QUICK TIP

After unpacking the trolley and while reading this manual, place the battery on charge while you assemble the unit. Plug battery into charger and charger into power source. The battery may be delivered with a charge but you should verify a full charge before using the trolley for the first time.

BASIC SET-UP

- Remove all components from carton. Note any damage with carrier.
- Install the two large drive wheels. The arrow design on the tire should face forward. Depress knob on inside wheel hub to fully seat wheel onto axle drive collars. The metal prongs should fully insert into the holes on the drive collar.



- Install front wheel. Review the following drawing and install the front wheel.



- Lift lower handle.
- Extend upper handle into desired position and secure by turning black locking knob.
- Load golf bag onto trolley. Balance weight of golf bag equally “side to side”. Secure golf bag with bungees.
- Securing your golf bag on the cart locks the cart in the “open” position. It is important that both top and bottom

bag straps are tight and your bag is firmly secured in the bag rests.

- Attach extension cable to battery. Place battery in a convenient pocket in golf bag where the cable will reach the battery port without stress.

TURNING ON YOUR GRI-975LI

Turn speed knob back counter clockwise to the stopped position. Plug battery cable into the electrical port on trolley handle. The LED on handle will be a solid blue. (When initially plugging in your battery if you see a flashing LED your speed knob is not at zero.) Trolley is ready to go. Turn speed knob forward to desired speed. To stop trolley turn speed knob back to zero.



Alternatively, the trolley may be controlled by using the push button at the end of the handle. (Where the blue LED is located). Simply push the button while the trolley is moving and the trolley will stop. The LED will triple flash. Push the button again to resume at the same pace.

Distance Control Function: when the trolley is stopped, press and hold the LED until it flashes rapidly. Release the button, the GRI-975Li will move forward for 10 seconds at the currently set speed. (Distance control function will not work when cart is stopped via the speed dial.)

To engage the “parking brake” stop caddy with on/off button. As a precaution always turn trolley across hill if parking on a hill. To disengage parking brake, turn speed dial to zero (carts with AMB must press the on/off button with speed @ zero)

LED Designations	Standard	With AMB
Plug in Battery with speed not at 0	Flashing LED	Flashing LED
Plug in Battery with speed a 0	Solid LED	Flashing LED
Cart stopped with on off button	Triple Flash	Triple Flash
Distance Control Functions	Rapid Flash	Rapid Flash
Low Voltage	Slow Flashing	Slow Flashing
High Current	Quick Flashing	Quick Flashing

FREE WHEEL MODE

In the event that you have a loss of power or have a need to pull the GRI-975Li backwards, you must put the Trolley into “Free Wheel Mode”. For “free wheel” mode depress button on hub and pull wheels out approximately 1/4 of an inch, making sure the wheels engaged into the axel. The metal prongs on the inside wheel hub will show and will **not** be engaged with the drive collar. You can now safely pull cart backwards slowly.

PRECAUTIONS

- 1) For best performance heavy cart bags are recommended. If you use a carry bag or stand bag you may need to add weight. (See # 4 below)
- 2) Consider the all-around weight distribution of your golf bag. Ensure the bag is balanced evenly side-to-side. Uneven weight distribution may lead to “tracking errors” i.e. too much weight on the right side will cause trolley to veer to the left.

- 3) The front wheel should stay grounded during play. If on steep inclines your trolley's front wheel comes off of the ground, maneuver front wheel down with handle.
- 4) If you are having issues keeping the front wheel down on the ground, increase the weight over the front wheel. Consider adding a water bottle full of sand inside a low pouch in your golf bag. Equally distribute the weight, use the center pouch or equal weight added to each side pocket.
- 5) During play, minimize the drain on the battery by avoiding taking the GRI-975Li trolley into the rough.
- 6) Avoid using the GRI-975 to pull you up hills.
- 7) Do not pull Trolley backwards while riding in a cart. If you need to pull trolley backwards for an extended distance, disconnect the battery and pull the main drive wheels out to the free wheel mode groove on the axel.

CAUTION: Wheels can disengage in sharp turns or from excessive speed.

BATTERY MAINTENANCE

Your GRI-975Li Trolley comes with a 24 volt, 7.5 Ah Lithium Ion battery.

Whenever possible we ship your battery fully charged. Before trying to operate your GRI-975Li, please verify that the Li battery is fully charged. Plug your battery into the charger; and then plug your charger into the power source. Your trolley is ready for play when your charger LED flips from orange to green. It is likely that your battery will need very little charge time before being ready for play the first time. Normal charge time is 3-4 hours *after a full round of golf.*

- ✓ Always ensure battery is connected to charger when connecting AND disconnecting charger from power source.
- ✓ Your battery charger should not be left plugged into the power source when not in use.
- ✓ The charger has a green LED light when inserted into a power source if it does not have a battery connected to it.
- ✓ Do pay attention to the charger lights and verify that the charger flips to orange when a depleted battery is plugged in. (Depleted meaning you played golf.)
- ✓ To maximize battery life, charge your trolley battery immediately following your round of golf. Charge your battery after any use, even if you only played 9 holes.
- ✓ The LED on the charger will turn green when battery is fully charged. A full charge usually takes between 3-4 hours. Charge the battery in the evening, unplug in the morning. Do not leave your battery on the charger for extended periods; do not leave the charger plugged into power source.
- ✓ Provided your next golf game is within 3 weeks your battery is ready to go and there is no need to top off.
- ✓ During periods of inactivity (i.e. winter storage) re-charge your battery overnight every 12 weeks. Battery life is 800 to 1000 charging cycles, depending on course conditions.
- ✓ Store your battery at normal room temperature. Avoid freezing temperatures.
- ✓ Do not store or charge battery on concrete surface.
- ✓ At the plug end of the battery cable check to see that the cable has not become loose or "unscrewed" from the plug. Tighten compression ring if needed.

- ✓ Take precautions and be careful to not drop the battery. The battery casing could crack and the subsequent battery life will be severely compromised.
- ✓ Do not strain or pull on battery cable. Always push silver slide latch on round plug when inserting and removing from cart or charger.

ALIGNMENT SYSTEM

If you have issues with your trolley not going straight you may have to adjust the tracking. Verify that the trolley has a tracking issue without a bag before making any adjustments. If you only have a tracking issue with the trolley when your golf bag is on the trolley adjust the weight in the golf bag.

In order to adjust the alignment you will need to loosen a locking CAP nut and two #2 Allen sets.

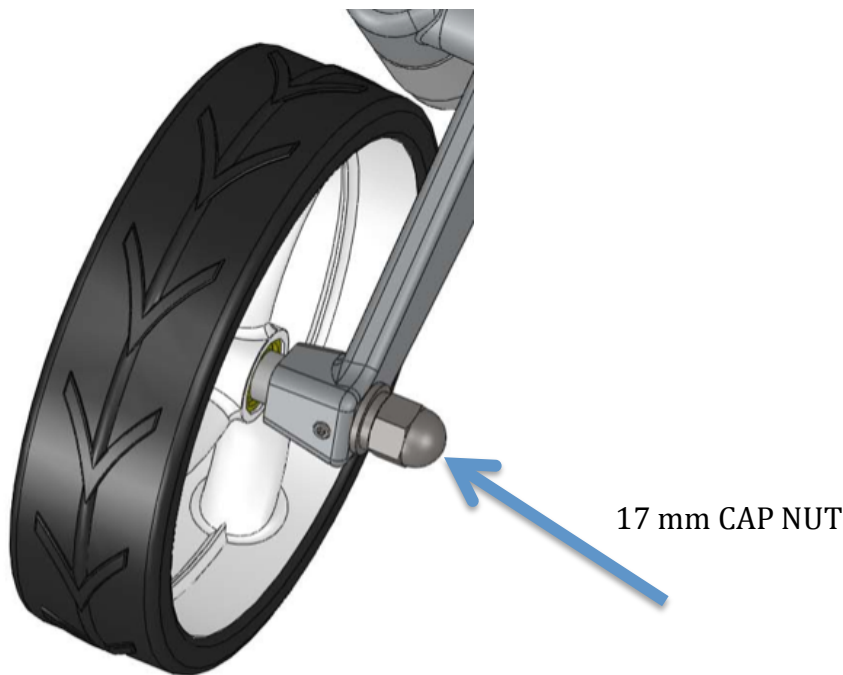

When standing in the front of the trolley looking at the front wheel, loosen the 17 mm nut on the right side of the front wheel.

Depending on how the trolley is tracking, will determine which way to turn the Allen set screws.

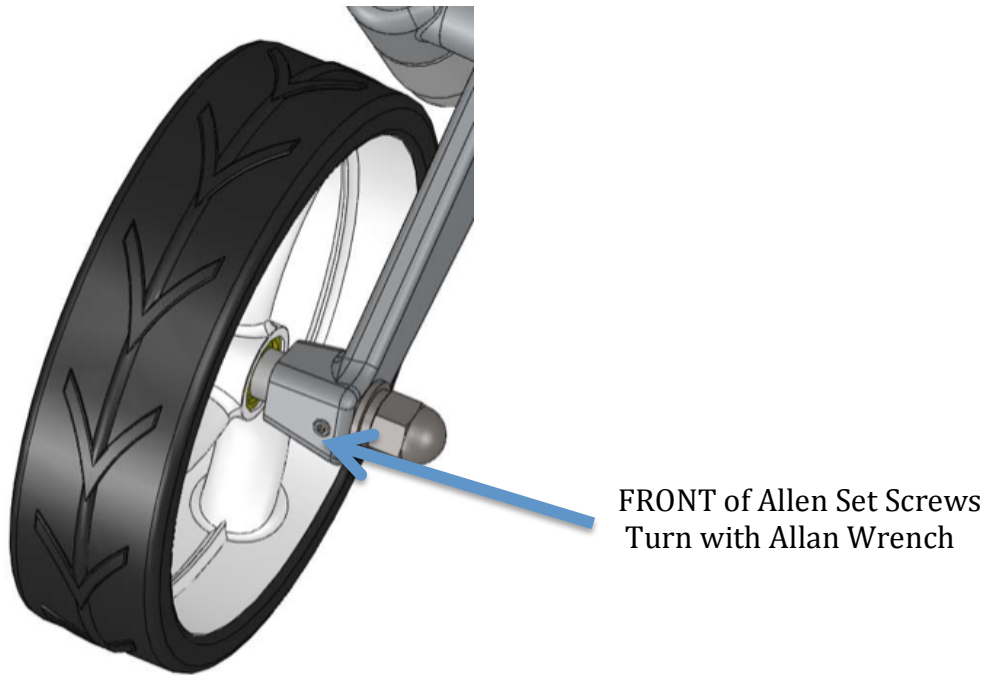

The Allen Set Screws should be gently turned on both the front and back sides an equal amount.

If the Trolley is tracking to the right, (when standing behind the trolley) turn the rear side of the Allen Set screw counter clockwise. Turn the front of the Allen Set screw clockwise. Turn both sides equally.

If the Trolley is tracking to the left (when standing behind the trolley) turn the front of the Allen Set screw counter clockwise and turn the rear side of the Allen Set screw clockwise.

Retighten 17 mm cap nut. Test and repeat if necessary.

QUICK TIP

When first using your trolley, practice in a large open area. Take the time to practice controlling trolley with the start stop switch on handle and using the distance control function.



FOR WARRANTY, SPARE PARTS AND ACCESSORIES:

Contact Us:

541-633-4308

<http://www.carttek.com>

Cart Tek Golf Carts

150 SE Logsdan St.

Bend, OR 97702

email: sales@carttek.com