

TPS3 11

Surge Protective Device



User Manual - Canada

SIEMENS



WARNING - Hazardous Voltage & Shock Hazard

Failure to Follow These Instructions Could Result in Death or Serious Injury

- Only qualified licensed electricians should install or service SPDs
- Hazardous voltages exist within SPDs
- SPDs should never be installed or serviced when energized
- Use appropriate safety precautions including Personal Protection Equipment
- Failure to follow these instructions can result in death, serious injury, and/or equipment damage
- This manual shall be read in entirety prior to installing

Bonding and Grounding Hazard

Verify that the neutral conductor in the service entrance equipment is bonded to ground in accordance with the National Electrical Code (NEC®) and all applicable codes.

Verify that the neutral terminal (XO) on the secondary side of distribution transformers are grounded to the system ground in accordance with the NEC® and all applicable codes.

During installation into an electrical system the SPD must not be energized until the electrical system is completely installed, inspected and tested. All conductors must be connected and functional including the neutral (if required). The voltage rating of the SPD and system must be verified before energizing the SPD.

Failure to follow these guidelines can lead to abnormally high voltages at the SPD. This may cause the SPD to fail. The warranty is voided if the SPD is incorrectly installed and/or if the neutral conductor in the service entrance equipment or downstream of separately derived systems is not bonded to ground in accordance with the NEC®.

Do Not Hi-Pot Test SPDs

Any factory or on-site testing of power distribution equipment that exceeds normal operating voltage such as high-potential insulation testing, or any other tests where the suppression components will be subjected to higher voltage than their rated Maximum Continuous Operating Voltage (MCOV) must be conducted with the SPD disconnected from the power source. For 4-wire systems, the neutral connection at the SPD must also be disconnected prior to performing high-potential testing and then reconnected after test completion.

Failure to disconnect SPD and associated components during elevated voltage testing will damage the SPD and will void the warranty.

Table of Contents

FAILURE TO FOLLOW THESE INSTRUCTIONS COULD RESULT IN DEATH OR SERIOUS INJURY	2
Do Not Hi-Pot Test SPDs	2
INTRODUCTION	4
Warning and Safety Information	4
Qualified Person	4
Danger.....	4
Warning	4
Caution	4
Do Not Hi-Pot Test SPDs	4
Industry Standards Changes - 2009	4
Simplified Explanation of Operation.....	5
Parts List and Inspection	5
Voltage Rating & Application	5
SPDs on Ungrounded Systems	6
Optional Flush Mount Installation Instructions	6
UL 1283 required language concerning the installation of EMI Filters	6
TPS3 11 INSTALLATION INSTRUCTIONS	7
Common Problems to Avoid	7
OPERATION	9
Diagnostic Indication.....	9
Phase indicator LEDs (Green)	9
Service LED (Red)	9
Audible Alarm Option	9
Dry Contact Option	9
Remote Monitor Accessory Option	9
MAINTENANCE	10
Troubleshooting & Service	10
Please contact us for any service related issues.	10
WARRANTY AND CUSTOMER SERVICE	10
Limited Warranty.....	10
Technical Support.....	10
Figures	
Figure 1: SPD Types	5
Figure 2: DIMENSIONS AND WEIGHT	5
Figure 3: Optional Flush Mount Installation.....	6
Figure 4: Conduit Installation.....	7
Figure 5: Typical Panel Installation	7
Figure 6: Installation Wiring Diagrams.....	8
Figure 7: Diagnostic Display.....	9
Figure 8: Dry Contact Pin Configuration	9
Tables	
Table 1: Specifications.....	5
Table 2: Model number decoder.....	6

Introduction

Thank you for choosing Siemens Surge Protective Device (SPD). This is a high quality, high energy surge suppressor designed to protect sensitive equipment from damaging transient overvoltages.

Proper installation is important to maximize performance. Please follow the steps outlined herein.

This entire user manual should be read prior to beginning installation. These instructions are not intended to replace national or local codes. Follow all applicable electrical codes to ensure compliance. Installation of this SPD should only be performed by qualified electrical personnel.

All Siemens SPDs are extensively tested in accordance with industry standards such as ANSI/IEEE C62.41.1, C62.41.2, C62.45, C62.62, C62.72, UL 1449, UL 1283, IEC 61643, etc.

Warning and Safety Information

This equipment contains hazardous voltages. Death, serious injury, or property damage can result if safety instructions are not followed. Only qualified personnel should work on or around this equipment after becoming thoroughly familiar with all warnings, safety notices, and maintenance procedures contained herein.

The successful and safe operation of this equipment is dependent upon proper handling, installation, operation, and maintenance.

Qualified Person

For the purposes of this manual and product labels, a QUALIFIED PERSON is one who is familiar with the installation, construction, and operation of this equipment, and the hazards involved. In addition, he or she has the following qualifications:

- (a) Is trained and authorized to energize, de-energize, clear, ground and tag circuits and equipment in accordance with established safety practices.
- (b) Is trained in the proper care and use of personal protective equipment (PPE) such as rubber gloves, hard hat, safety glasses or face shields, flash clothing, etc. in accordance with established safety practices.
- (c) Is trained in rendering first aid.

Danger

For the purposes of this manual and product labels, DANGER indicates an imminently hazardous situation, which, if not avoided, will result in death or serious injury.

Warning

For the purposes of this manual and product labels, WARNING indicates failure to following these instructions can result in death, serious injury, or equipment damage.

Caution

For the purposes of this manual and product labels, CAUTION indicates a potentially hazardous situation which, if not avoided, could result in minor or moderate injury.

These instruction do not purport to cover all details or variations in equipment, nor to provide for every possible contingency to be met in

connection with installation, operation or maintenance. Should further information be required by the user, please call Siemens Technical Support at 1.888.333.3545 for assistance.

Do Not Hi-Pot Test SPDs

Any factory or on-site testing of power distribution equipment that exceeds normal operating voltage such as high-potential insulation testing, or any other tests where the suppression components will be subjected to higher voltage than their rated Maximum Continuous Operating Voltage (MCOV) must be conducted with the SPD disconnected from the power source. For 4-wire systems, the neutral connection at the SPD must also be disconnected prior to performing high-potential testing and then reconnected after test completion.

Failure to disconnect SPD and associated components during elevated voltage testing will damage the SPD and will void the warranty.

Industry Standards Changes - 2009

UL 1449 Third Edition and 2008 NEC® Article 285 generated substantial changes.

- The term TVSS changed to SPD
- Types 1, 2, 3 & 4 SPDs are created
- UL 1449 clamping voltage performance testing changed from 500A to 3,000A
- UL 1449 added new I nominal testing (In), which consists of more rigorous duty-cycle testing

The SPD Type category is important to understand before installing any SPD. Type 1 and 2 SPDs are fully UL Listed devices whereas Type 4 SPDs are UL Recognized devices.

Type 1 – Installed on line or load side of the Main Overcurrent Protection (OCP), similar to what you knew as SSA, except now includes rigorous safety testing. Includes all OCP & safety disconnectors inside the SPD

Type 2 – Installed on load side of the Main OCP, similar to what you know as hardwired SPD, and it may require external OCP.

Type 3 – Point of Utilization, direct plug in type devices, similar to what you know as surge strips. These devices are intended for installation 10 meters from the panel (rational based on IEEE Cat. A location).

Type 4 – Surge suppression components, could be a basic component or a complete module. Type 4 components can be tested for Type 1, Type 2 or Type 3 applications.

Figure 1: SPD Types

2008 NEC Art 285 & UL 1449-3

SPD Types: Types 1, 2, 3, & 4

Based on Location within electrical distribution system
(also coincides with ANSI/IEEE C62.41.2 - 2002 Categories C, B & A)

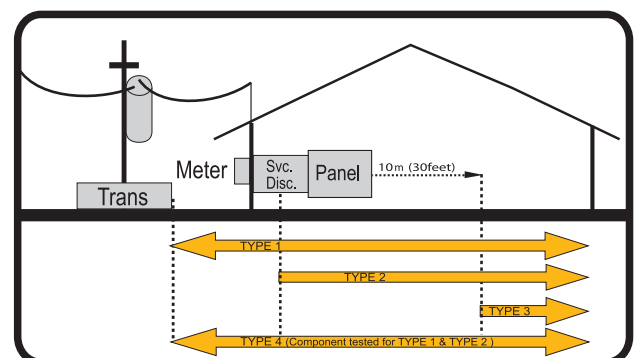

For further information, please review latest editions of NEC® Art. 285, UL 1449, contact your local Siemens sales office or contact Siemens Technical Support at 1.888.333.3545.

The TPS3 11 is a Type 1 SPD. The TPS3 11 is suitable for use almost anywhere (not as a plug-in SPD). Type 1 SPDs are evaluated more rigorously by UL 1449 for 2008 NEC® Article 285 compliance. Type 1 SPDs and their connecting leads have been evaluated for line side applications without need for supplemental overcurrent protection. Type 1 SPDs include internal overcurrent protection. As a generalization, there are practical maintenance reasons for installing on the load side of the main overcurrent device (i.e. Type 2 installation). When connected on load side of main disconnect, we recommend connecting via a 30A circuit breaker due to 10 AWG conductors. The circuit breaker serves as a disconnect switch and provides NEC® imposed short circuit protection to the conductors in Type 2 or 4 applications.

Simplified Explanation of Operation

SPDs sense overvoltage and create a momentary short circuit to redirect harmful surge energy to earth ground. SPD's are not a one time device. They reset automatically and wait for the next surge. SPDs are capable of repeating this function thousands of times.

Parts List and Inspection

Items included in the package consist of the following:

- 1 TPS3 11 SPD including 3' (~1m) conductors
- 1 User's Manual (this document)

If the Flush Mount Kit was ordered, additional parts are supplied as follows:

- 1 Flush Mount Plate
- 1 Flush Mount Installation Instructions
- 4 Mounting Screws

Carefully inspect each item in the package for signs of damage. If damage is found, please contact Siemens Technical Support: 1.888.333.3545. For more information about this product or other Siemens products, visit www.purgethesurge.ca.

Figure 2: DIMENSIONS AND WEIGHT

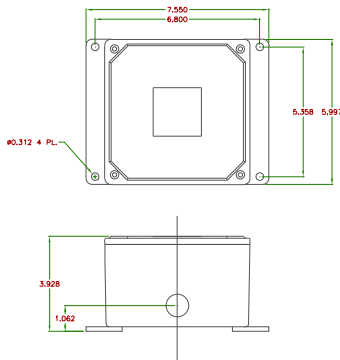

TPS3 11's have demonstrated 200kA Short Circuit Current Ratings (SCCR) including leads (120/240V Split phase models have 100kA SCCR). See UL Label markings on SPD or see Data Sheet for specs.) Supplemental overcurrent protection is not required to protect this SPD. However, NEC® convention requires that connecting conductors have overcurrent protection in Type 2 or 4 applications. Follow applicable codes.

This device features internal overcurrent and overtemperature protection that will disconnect effected surge suppression components at the end of their useful life, but will maintain power to the load – now unprotected. If this situation is undesirable for the application, follow these instructions for replacing the device. TPS3 11 is ultrasonically welded closed and contains no user serviceable parts.

Table 1: Specifications

Specifications	
Temperature Operating	-40°C (-40°F) to 60°C (+140°F)
Temperature Storage	-55°C (-67°F) to 65°C (+149°F)
Wire Size & Installation Torque	10 AWG; 18 inch-pounds
Appropriate Circuit Breaker based on conductor size	30A (SPD includes internal OCP)
NEMA 250 Enclosure Rating	Type 4X with appropriate sealing & sealing condulets

Voltage Rating & Application

Before installing SPD, verify by nameplate voltage or model number that it has the same voltage rating as the power distribution system. If unsure call Siemens Technical Support at 1.888.333.3545 before proceeding. The SPDs specifier or user should be familiar with the configuration and arrangement of the power distribution system. The system is defined by how the secondary windings of the transformer supplying the service entrance main or load are configured. This includes whether or not the transformer windings are referenced to earth via a grounding conductor. The system configuration is not based on how any specific load or equipment is connected to a particular power distribution system. SPDs should be installed per the distribution system, not per a load or motor's wiring connection.

For example, suppose a 480V three phase motor appears to be connected as a 480V Delta. In actuality, the serving distribution system might be a 480Y/277V grounded Wye, with or without a neutral pulled to the motor or MCC. The system is still a 480Y/277V Wye, even though the load is connected as a Delta. A grounded Wye has a defined reference to ground (i.e., neutral is bonded to ground). In contrast, some Delta systems are ungrounded, which have no reference to ground.

Table 2: Model number decoder

Model	Voltage Code	Service Voltage
TPS3A11	A	240/120V 1Ø, 3W Plus Ground,
TPS3B11	B	240/120V 3Ø, 4W Plus Ground High Leg Delta
TPS3C11	C	208Y/120V 3Ø, 4W Plus Ground
TPS3D11	D	240v 3Ø, 3W Plus Ground
TPS3E11	E	480Y/277V 3Ø, 4W Plus Ground
TPS3F11	F	480v 3Ø, 3W Plus Ground
TPS3G11	G	600v 3Ø, 3W Plus Ground
TPS3K11	K	380Y/220V 3Ø, 4W Plus Ground
TPS3L11	L	600Y/347V 3Ø, 4W Plus Ground
TPS3S11	S	400Y/230V 3Ø, 4W Plus Ground

SPDs on Ungrounded Systems

Caution – Ungrounded systems are inherently unstable and can produce excessively high line-to-ground voltages during certain fault conditions. During these fault conditions, any electrical equipment including an SPD, may be subjected to voltages which exceed their designed ratings. This information is being provided to the user so that an informed decision can be made before installing any electrical equipment on an ungrounded power system.

Optional Flush Mount Installation Instructions

Caution: The chassis of the TPS3 11 unit can fall into the wall cavity if the four screws attaching the faceplate to the chassis are removed. Use caution not to drop the TPS3 11 unit into the wall during installation or service.

The TPS3 11 unit is approximately 4.0" deep. The unit will not mount flush unless there is at least 3.75" of clearance. The unit is designed to mount flush on a typical "2 x 4" stud wall with drywall.

Depending on the depth of the wall cavity, there are two installation procedures. The preferred installation utilizes Back Flange Mounting. The back flange supports the weight of the TPS3 unit and service procedures are greatly simplified. If this can not be accomplished, an alternate Front Flange Mount is possible. Please note that the front flange installation may create servicing difficulties in the future.

Preferred Installation - Back Flange Mounting: Mount as close as possible to the protected panel. Create a wall opening approximately 6 3/4" tall by 6 1/16" wide. See drawing. (Rotate dimensions 90° as appropriate depending on orientation.) Configure an appropriate backing plate inside the wall cavity 3 7/8" from the wall face such that the unit will be supported from its back. Note the mounting holes on the back flange attachments. Be careful not to drop the unit into the wall. Configure electrical conductor and conduit connection consistent with the installation instructions on page 5. Preplan connections such that they are completed prior to fastening the unit to the backing plate. Install faceplate/cover prior to energizing and testing the unit.

Alternate Installation - Front Flange Mounting: This method is not preferred for installation as servicing is substantially more difficult. Extra care should be taken to NOT DROP the TPS3 unit into the wall. Mount as close as possible to the protected panel. Create a wall opening approximately 6 3/4" tall by 6 1/16" wide. See drawing. (Rotate dimensions 90° as appropriate depending on orientation.) Preplan and pre-connect electrical conductor and conduit connections such that they are completed prior to fastening the TPS3 unit to the wall. Note that removing the four screws attaching the front faceplate to the unit chassis will cause the unit to fall inside the wall.

UL 1283 required language concerning the installation of EMI Filters

- a) An insulated grounding conductor that is identical in size and insulation material and thickness to the grounded and ungrounded circuit supply conductors, except that it is green with or without one or more yellow stripes, is to be installed as part of the circuit that supplies the filter. Reference should be made to Table 250-122 of the National Electrical Code regarding the appropriate size of the grounding conductor.
- b) The grounding conductor mentioned in item a is to be grounded to earth at the service equipment or other acceptable building earth ground such as the building frame in the case of a high-rise steel-frame structure.
- c) Any attachment-plug receptacles in the vicinity of the filter are to be of a grounding type, and the grounding conductors serving these receptacles are to be connected to earth ground at the service equipment or other acceptable building earth ground such as the building frame in the case of a high-rise steel-frame structure.
- d) Pressure terminal or pressure splicing connectors and soldering lugs used in the installation of the filter shall be identified as being suitable for the material of the conductors. Conductors of dissimilar metals shall not be intermixed in a terminal or splicing connector where physical contact occurs between dissimilar conductors unless the device is identified for the purpose and conditions of use.

Figure 3: Optional Flush Mount Installation

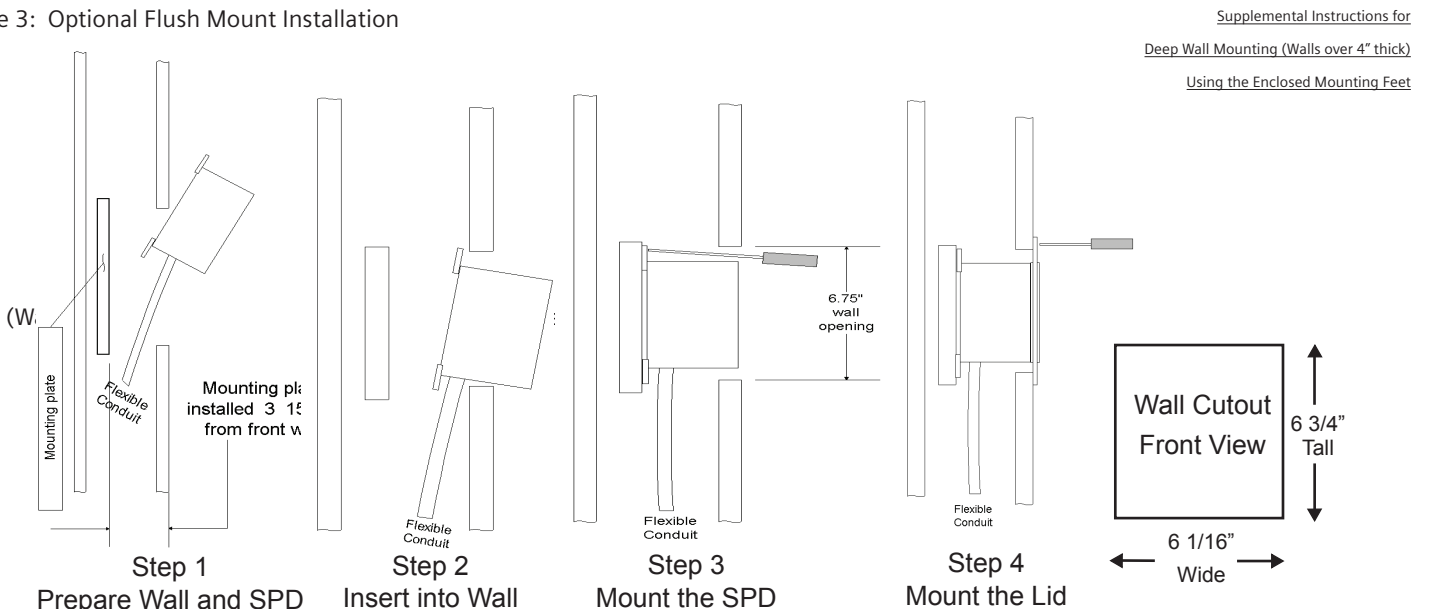

CAUTION

CONDUCTING DIELECTRIC AND/OR HI-POTENTIAL TESTING WILL CAUSE INTERNAL DAMAGE TO SPD UNIT.

Do not perform dielectric or high potential tests with the SPD unit installed.

DANGER

Hazardous voltage.
Will cause death or serious injury.

Keep Out.
Qualified personnel only.
Disconnect and lock off all power before working on this equipment.

TPS3 11 Installation Instructions

Common Problems to Avoid

- Confirm System voltage to SPD voltage (120V SPD will fail instantly on 240V, 277V, etc.)
- Locate SPD close so leads are short & straight as possible (or will seriously hurt performance)
- Make sure N-G or XO bonding meets NEC® (or will prematurely fail SPD)
- Energize SPD AFTER system is stabilized & checked (inadvertent system problem may fail SPD)
- SPDs are regulated by NEC® Article 285 and UL 1449
- Never Hi-Pot test any SPD (will prematurely fail SPD)

Pre-Plan your installation. You will need to accomplish the following:

- Meet all National and Local codes (NEC® Article 285 addresses SPDs)
- Mount SPD as close to panel or equipment as possible to keep leads short
- Ensure leads are as short and straight as possible, including neutral and ground. Consider a breaker position that is closest to the SPD and the panel's neutral & ground
- Suggested breaker & conductor size is 50A-30A with 8 AWG
- Make sure system is grounded per NEC® and clear of faults before energizing SPD.

1. Use a voltmeter to check all voltages to ensure correct SPD
2. If unit has Flush Mount option refer to Flush Mount Installation Instructions following
3. If SPD has Dry Contact pre-plan its installation
4. Remove power for panel. Confirm panel is deenergized.
5. Identify breaker location and SPD location
6. Remove an appropriately sized knockout from panel
7. Mount SPD, use appropriate weatherproofing equipment as needed
8. Connect conductors as appropriate – short and straight as possible (Note that Hi-Legs are Phase B)
9. Label or mark conductors as appropriate (neutral: white, ground: green, energized: black, hi-leg: orange)
10. Make sure system is bonded per NEC® and is clear of hazards or faults before energizing (N-G bonding not per NEC® will fail SPDs: #1 cause of SPD failures)
11. Energize and confirm proper operation of indicators and/or options

A sealing O-ring is provided. SPD can be chase-nipple mounted (nut is provided).

Note that any conduits must be installed correctly.

Figure 4: Conduit Installation

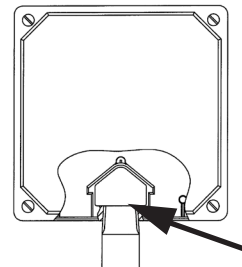

CORRECT INSTALLATION
Threaded 6 Full Turns

INCORRECT INSTALLATIONS

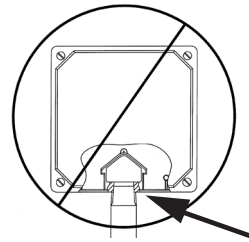

POOR ENGAGEMENT
Conduit needs to be threaded in farther

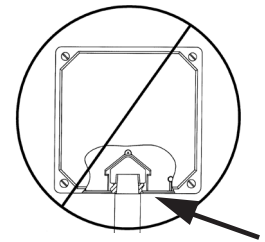

OVERTIGHTENED
Stresses box, ONLY 6 full turns required

Figure 5: Typical Panel Installation

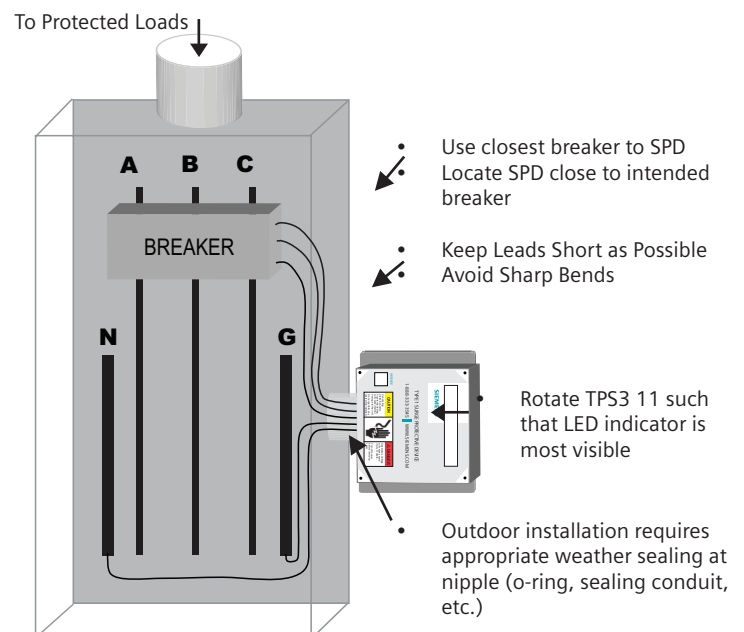
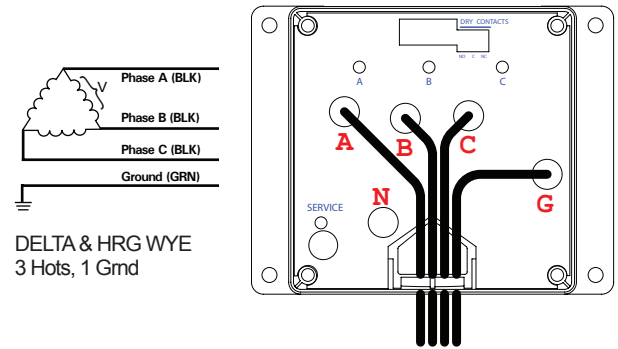
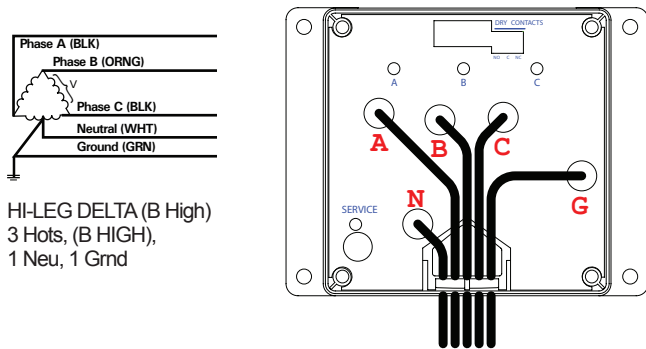
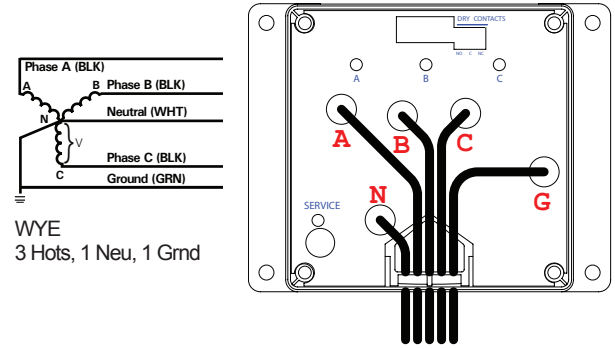
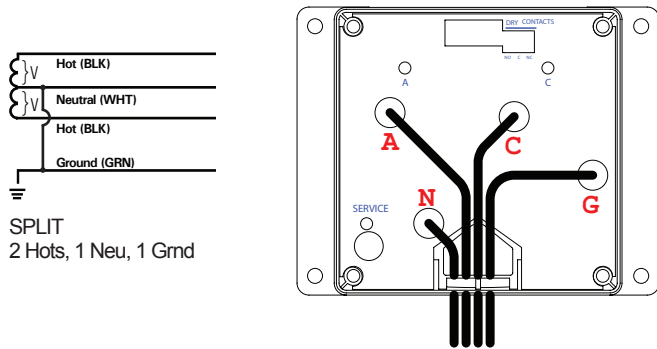

Figure 6: Installation Wiring Diagrams



Operation

Diagnostic Indication

Phase indicator LEDs (Green)

Each phase is equipped with a Green LED. Should complete loss of surge protection occur on each phase, the Green LED will extinguish and the Red Service LED will flash. Every suppression element is monitored. Note that the Green LED indicators will drop out due to loss of power or severe under voltage.

Service LED (Red)

Flashes in the event of a problem. The Red Service LED is slaved to the Green LEDs via logic and will illuminate when any Green LED extinguishes.

Audible Alarm Option

If equipped with optional Dry Contact and Audible Alarm, these options are slaved via logic to the Green LEDs. In the event of a problem, the dry contacts will change state and the audible alarm will sound. The audible alarm may be silenced by deenergizing the SPD.

Figure 7: Diagnostic Display

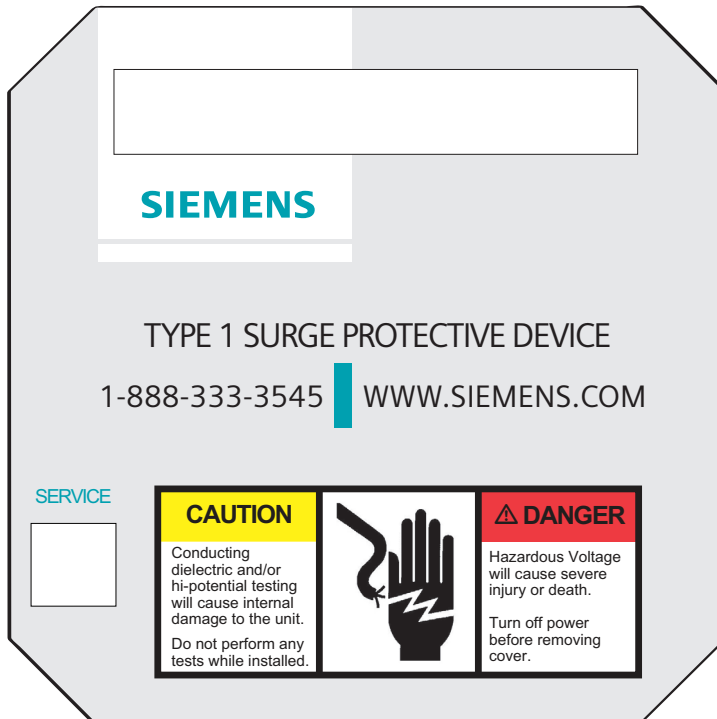

Dry Contact Option

Two sets of Form C dry contacts are included with the Dry Contact option. Dry Contacts change state during inoperative conditions, including loss of power. Any status change can be monitored elsewhere via Dry Contacts.

A Terminal Block includes two sets of Normally Open (N.O.) and Normally Closed (N.C.) contacts. Both sets of contacts operate the same. This is shown in Figure 8.

Figure 8: Dry Contact Pin Configuration



A typical application using a Normally Closed configuration would connect to one set of the N.C. and Common terminals. During an inoperative condition, the SPDs dry contact would change state from normally closed to open. We generally suggest the Normally Closed configuration because it will detect a wiring defect, such as cut wire(s), where N.O. will not.

Please note:

Dry Contacts are designed for low voltage or control signals only.

Maximum switching current is 5A

Maximum switching voltage is 240V DC or AC.

Higher energy applications require additional relay implementation outside the SPD.

An optional Remote Monitor accessory is available to provide visual and audible status. The Remote Monitor will consume one of the two sets of Dry Contacts.

Remote Monitor Accessory Option

A Remote Monitor is available for remote annunciation. It requires a standalone 120V power source (wall plug transformer) and uses one set of Form C dry contacts. The Remote Monitor can be configured to monitor several Siemens SPDs simultaneously. Installation is detailed in a separate document. Contact factory as appropriate.

 <h1 style="margin: 0;">CAUTION</h1>
<p>CONDUCTING DIELECTRIC AND/OR HI-POTENTIAL TESTING WILL CAUSE INTERNAL DAMAGE TO SPD UNIT.</p> <p>Do not perform dielectric or high potential tests with the SPD unit installed.</p>

	 <h1 style="margin: 0;">DANGER</h1>
<p>Hazardous voltage. Will cause death or serious injury.</p> <p>Keep Out. Qualified personnel only. Disconnect and lock off all power before working on this equipment.</p>	

Maintenance

SPDs require minimal maintenance. Periodic inspection of diagnostic indicators is recommended to ensure proper operation.

Troubleshooting & Service

Please contact us for any service related issues.

Quality SPDs withstand severe duty and attempt to protect their load until failure. There are electrical anomalies that SPDs cannot protect against. These are generally Sustained Overvoltages also known as Temporary Overvoltages (TOVs). In this context, Sustained Overvoltages may be only a few cycles. Failed SPDs tend to be symptoms, not root causes. A failed SPD is usually a sign of other problems within the electrical distribution system. As a generalization, the single largest cause of SPD failures is reference to ground issues. If the SPD shows problems on startup, there is reasonable chance of bonding/grounding/misapplication issue. This permanently damages the unit. If not corrected, it will happen again.

Warranty and Customer Service

Limited Warranty

Siemens warrants its AC Panel protection products against defective workmanship and materials for 10 years. Liability is limited to the repair or replacement of the defective product at Siemens' option. A Return Material Authorization number (RA#) must be given by the company prior to the return of any product. Returned products must be sent to the factory with the transportation charges prepaid. In addition, the company also warrants unlimited replacement of modular and component parts within the warranty period previously described.

The company specifically disclaims all other warranties, expressed or implied. Additionally, the company is not be responsible for incidental or consequential damages resulting from any defect in any product or component thereof.

The sales contract contains the entire obligation of Siemens. This instruction manual shall not become part of or modify any prior existing agreement, commitment or relationship.

Technical Support

1.888.333.3545

Prior to calling Siemens Technical Support for assistance or ordering parts, please have the following information available:

SPD model number: _____
 Manufacture date: _____
 Date of Purchase: _____
 Your order number: _____

Return Shipment Address:

Siemens - Attn: RA # _____
 14550 58th Street North
 Clearwater, FL 33760

Siemens Canada Limited
1577 North Service Road East
Oakville, ON L6H 0H6

SPD Hotline: 888.333.3545
info@purgethesurge.ca