

DJI E800

Multicopter Propulsion System

User Manual

V1.0 2015.01

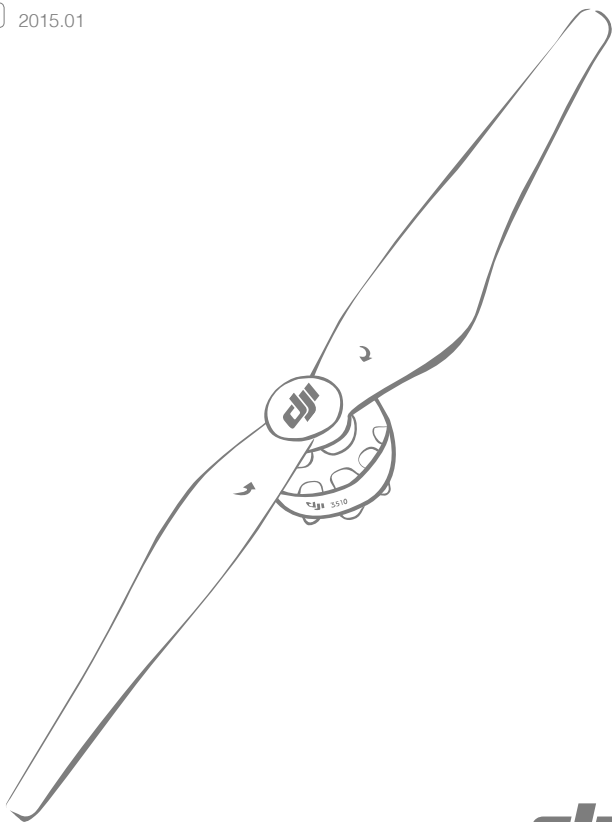

Disclaimer

Thank you for purchasing the E800 (hereinafter referred to as “product”). Read this disclaimer carefully before using this product. By using this product, you hereby agree to this disclaimer and signify that you have read it fully. Please strictly install and use this product in accordance with the manual. DJI assumes no liability for damage(s) or injuries incurred directly or indirectly from using, installing or refitting this product improperly, including but not limited to using accessories not designated. Ensure your ESC firmware matches the motor you will attach it to. Otherwise, you are responsible for all consequences caused by your own conduct.

This device complies with part 15 of the FCC Rules.

DJI is the registered trademark of SZ DJI Technology Co., Ltd. (abbreviated as “DJI”). Names of product, brand, etc., appearing in this manual are trademarks or registered trademarks of their respective owner companies. This product and manual are copyrighted by DJI with all rights reserved. No part of this product or manual shall be reproduced in any form without the prior written consent or authorization of DJI.

This disclaimer is made in various language versions; in the event of divergence among different versions, English version shall prevail.

Cautions

When powered on, the motors and propellers will rotate very quickly and may cause serious damage and injury. Therefore, please always be aware for your safety.

1. Always fly your aircraft a safe distance away from people, animals, high-voltage lines and other obstacles.
2. Do not get close to or touch the motors or propellers when powered on, as this may cause serious injury.
3. Make sure there is no short circuit or open circuit.
4. Check that the propellers and the motors are installed correctly and firmly before flight.
5. Check whether all parts of your aircraft are in good condition before flight. Do not fly with worn or broken parts.
6. Use compatible DJI parts.

Legend



Important



Hints and Tips



Reference

If you have any problems you cannot solve, please contact your local dealer or DJI customer service.

DJI Support Website:

www.dji.com/support



About

The E800 Multirotor Propulsion System is a tuned propulsion system customized for multi-rotor aircraft weighing 3 to 5 kg. It is efficient, reliable and minimizes vibrations. A revolutionary Electronic Speed Control (ESC) with a sinusoidal drive replaces the traditional square wave drive, and along with the new AC permanent magnet synchronous motor, the whole propulsion system is brought into an era of higher efficiency while providing a steady torque output. The integrated sensors and patented algorithms give the whole system a high level of intelligence and redundancy, and advanced features include closed loop torque control, active braking and energy optimization, real-time system health diagnosis, distinct functional redundancy for the communication link, and more. Furthermore, the ESC's firmware can be upgraded by users, enabling you to enjoy the continual development of the system. The E800 uses new quick-release propellers, which are designed to prevent propellers from flying off during active braking. Together with the energy optimization function of the new ESCs, propulsion performance is more efficient than ever before.

1. In the Box

Standard Package

The E800 is available in two different package configurations. The descriptions below correspond with the Quad-rotor and Hexa-rotor packages, respectively. Please ensure that you have the correct quantities of each part before beginning the installation process or using the product.

E.g. "1345 Quick-Release Propeller Pair x4 or x5" indicates that there are four pairs of propellers included in the configuration for Quad-rotors and five pairs of propellers included in the configuration for Hexa-rotors.

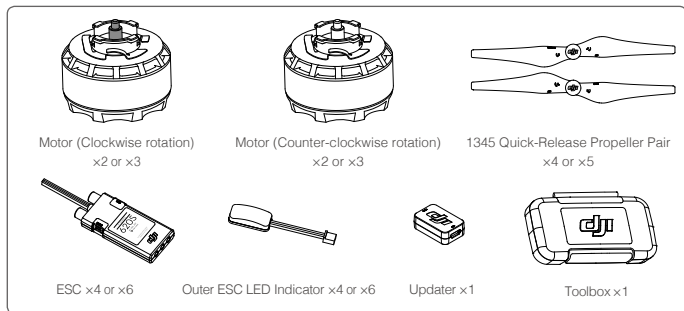

In the toolbox: Power hub, Screws (M2.5x6.3), Screws (M3x8.1), Screws (M3x5.5), Wrench for propellers, Foam double sided adhesive tape, 2.0 mm hexagonal wrench, etc.

Optional Package 1345 Self-tightening Propeller Pair
1242 Self-tightening Propeller Pair



2. Gain Value Settings

The new E800 ESC, with a sinusoidal drive replacing the traditional square wave drive, offers

improved acceleration and deceleration performance. Before using, reduce the gain values according to your flight control system and frame to achieve the same sensitivity as older ESCs (which use a traditional square wave drive). The table below shows typical gain values when using the E800 with a DJI A2 flight control system and a frame which has a diagonal wheelbase of 580 mm:

Basic			Attitude		
Pitch	Roll	Yaw	Pitch	Roll	Vertical
60%	60%	60%	204%	204%	100%

3. Connecting the ESCs

Tools Required

Tools: Electric soldering iron & soldering tin **Use:** Soldering each ESC's power cables to the power hub

- 1) Check the color tags on the ESC cables to identify the default color of the ESC LED indicator (red or green). Mount the ESCs onto the appropriate positions of your aircraft according to the LED color. Note: The LED color can be adjusted in DJI ESC Assistant.
- 2) Please solder each ESC to the power pads on the power hub as shown in the figure below. Make sure that the solder is firmly attached on the power pads and that there is no possibility for a short circuit. The power cable is a coaxial power cable. Do not damage the protector on the red cable to avoid short circuit.
- 3) Connect the signal cable to your controller. The orange wire of the signal cable is for the control signal; the brown wire of the signal cable is for the GND; and the red wire is reserved.
- 4) Connect the motor to the ESC. Test the motor and make sure the rotation direction of each motor is correct. If not, switch the position of any two cables that are connecting the motor to the ESC to change the rotation direction.

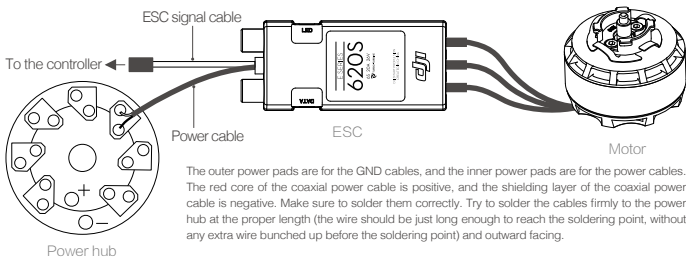

Make sure there is no short circuit or open circuit.



It is recommended that you solder a power connector onto the power hub.

4. Assembling the Propellers



Quick-Release Propellers

- 1) Unpack the propellers and motors.

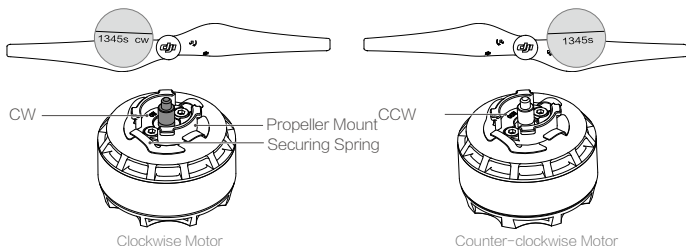

The propellers with a CW mark should be mounted to clockwise motors, which have a black propeller

screw and a CW mark on the propeller mount. The propellers without the CW mark should be mounted to counter-clockwise motors, which have a silver propeller screw and a CCW mark on the propeller mount.

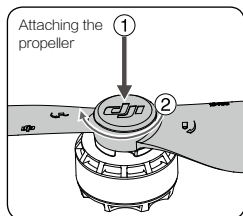
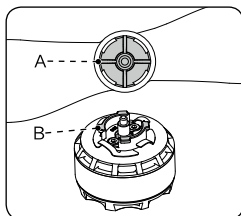

- 2) Align the gap A inside the propeller nut with a fin B on the Propeller Mount.
- 3) Press the propeller down onto the mount firmly and, while holding the propeller pressed down, rotate the propeller in the lock direction  until you feel it secure in place.
- 4) To remove the propeller, press the propeller down firmly and, while holding the propeller pressed down, rotate the propeller in the unlock direction  until it can be removed easily.



-  **Lock:** Tighten the propeller by rotating it in this direction.
-  **Unlock:** Remove the propeller by rotating it in this direction.





- Active braking function is enabled by default, and is for use with the standard quick-release propellers. Using this function with self-tightening propellers may cause the propellers to fly off or other flight problems.
- Be sure to press the propellers down firmly until they are all the way down before rotating to attach or detach them from the motors. Otherwise the propeller or propeller mounts may be damaged.
- When attaching a new propeller for the first time, it may not secure in place properly after rotating, because the hole on the propeller nut is blocked. In this case, pull the propeller up to help lock it in position. Then hold the motor in place and try to rotate the propeller. If it can't be loosened without pressing down, it is locked in place.
- When storing for an extended period, remove the quick-release propellers to prevent undue wear on the spring locks.



Active braking: The motor will provide reverse torque actively to slow down the propeller, and the rotational energy will be recovered.

Self-tightening Propellers (Optional)

- 1) Select "Self-tightening propeller" in the DJI ESC Assistant. (Refer to [7. Updating your ESCs](#) Page 7 for details)
- 2) Remove the two screws (M3) on the top of the motor. Then remove the propeller mount and securing spring.
- 3) Attach the propeller with a silver nut onto the counter-clockwise motor (which has a silver propeller screw). Attach the propeller with a black nut onto the clockwise motor (which has a black propeller screw).
- 4) **Tighten** the propeller by rotating it in the lock direction .
- 5) Remove the propeller by rotating it in the unlock direction .



- "Quick-release propeller" is set by default. When changing the type of the propeller, be sure to select the corresponding type in the DJI ESC Assistant.
- DO NOT use any thread locker on the propeller or motor threads.

5. Mounting the Motors

Mount each motor to a frame arm according to the size of the assembly hole.

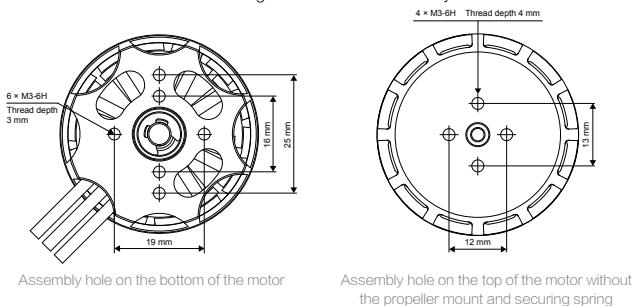

- The screw size is M3. Mount the motors using appropriate screws.
- Note the thread depth and the size of the screws. Using screws that are too long or too large may damage the motor.

6. ESC Ports Description

There are two ports on every ESC. They are ① Data/ESC Firmware Update Port and ② Outer ESC LED Port. Identify the marks on the ESC.

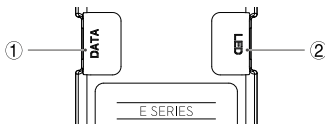



Ensure your ESC firmware matches the motor you will attach it to. Refer to the tag on back of the ESC to see the default firmware version.



- Mount the outer ESC LED indicators according to your needs.
- The Data/ESC Firmware Update Port is used to update the ESC firmware and adjust the ESC. To do this, visit the official DJI website to download the DJI ESC Assistant.

<http://www.dji.com/product/e800/download>



7. Updating Your ESCs

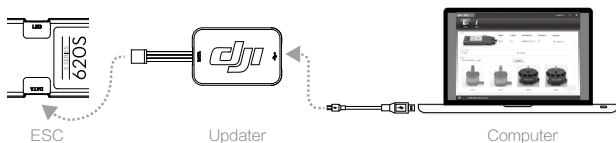

Unplug any other serial devices connected to your computer before updating. Then follow the instructions below:









- 1) Download the ESC Assistant installer from the DJI website. Run the installer and follow the prompts to finish the installation.
- 2) Connect one end of the Updater to the Data/ESC Firmware Update Port. Connect the other end of the Updater to a computer with a Micro-USB cable. Power on the ESC. DO NOT disconnect until configuration is finished.
- 3) Run the ESC Assistant and wait for the ESC to connect. Watch the indicators on the bottom of the screen. When connected successfully, the Computer Connection status will be solid green and Data Exchange Indicator will blink blue.
- 4) Click on the [View] page. In the "ESC" section, check the current firmware version and ensure the installed firmware is the latest version. If not, click the link and follow the prompts to upgrade.
- 5) The color of the ESC LED indicators, the type of propeller, etc. can also be adjusted through the DJI ESC Assistant.

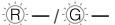

If the ESC is not automatically recognized by the DJI ESC Assistant (the indicators on the bottom of the screen show a solid green and an inactive blue), check whether there is more than one DJI Updater, FTDI USB adapter, or other developer tool (including, but not limited to, BeagleBone, Raspberry, Arduino, etc.), which may use the FTDI chipset, connected to the computer. If any of these FTDI devices are connected, simply unplug them and keep the DJI Updater connected to the computer. Then, restart the DJI ESC Assistant and the ESC system to form a successful connection.

8. ESC LED Indicators & Sound Description

The description is the same for both outer ESC LED indicators and inner ESC LED indicators, as shown below:

LED Indicators	Sound	Description
 Yellow, Green blinking in turn	None	Motor is being recognized.
 Red or Green blinking slowly	♪1356	Ready.
 Solid Red or Green	None	Motor starts normally.
 Red, Yellow blinking in turn	None	Fail to Self-Test.
	BB---BB---BB---BB... BBB---BBB---BBB...	Input voltage is abnormal. The motor parameters don't match the firmware data saved in the ESC.
 Quick Yellow blinking	BBBBBB...	Throttle stick is not at the bottom position.
 Slow Yellow blinking	B-----B-----B...	No signal input.
 — Solid Yellow	None	Motors are rotating at full throttle.
 Quick Red blinking	None	Error, land your aircraft immediately*

* You can learn more about any errors by connecting the ESC to the DJI ESC Assistant.



You can understand the working status by observing the LEDs and listening to the sound of the ESC.

9. Specifications

Max Thrust	2100 g/rotor @ 25 V (Sea Level)
Takeoff Weight Recommended	800 g/rotor
Battery Recommended	6S LiPo
Working Temperature	-10 ~ 40°C
ESC	
Max Allowable Voltage	26 V
Max Allowable Current (Persistent)	20 A
Signal Frequency	30 ~ 450 Hz
Battery	3S ~ 6S LiPo
Weight (with cable)	43 g
Weight (without cable)	30 g

Motor	
Stator Size	35×10 mm
KV	350 rpm/V
Weight	106 g
Propeller	
Diameter / Thread Pitch	1345 Propellers: 13×4.5 inch 1242 Propellers: 12×4.2 inch

The content is subject to change.

Download the latest version from
<http://www.dji.com/product/e800>



If you have any questions about this document, please contact DJI by sending a message to DocSupport@dji.com.