

SRAM

DEALER TECHNICAL MANUAL

derailleur system components

1999

english



DEALER TECHNICAL MANUAL 1999

derailleur system components

TABLE OF CONTENTS

INTRODUCTION

Who we are & what we make	4
New in 1999	5
Evolution of SRAM Grip Shift shifters	5
SRAM technology	
What is ESP?	6
What is Grip Shift?	6
What is DI.R.T.?	7
What is Spectro?	7
What is SRAM Composite?	7
Power Link Section	7

SUPPORT

Distributors	10
Who to call	12
SRAM 2 year warranty	12

TIPS & GUIDELINES

Index shifting overview	14
Troubleshooting tips	16
Lubrication guidelines	17
Make it shine	18

INSTRUCTIONS

Rear Derailleurs	
ESP Rear Derailleur	20
DI.R.T. Rear Derailleur	22
Front Derailleurs	
ESP & DI.R.T. Front Derailleur	25
Troubleshooting Rear & Front Derailleurs	27
Shifter	
ESP 9.0SL, 9.0, 7.0, Plasma	28
5.0 Centera	29
MRX	30
Quarz, Neos, Spectro, Bandix, Traxx	32
Sealing systems	
Nightcrawler	33
Hubs	34
Cassettes	38
Crank Sets	39
Chains	40
Brakes	42
Brakelevers	43
Integrated Brake Shifters	44

APPENDIX

Spare Parts	46
Glossary	46

WHO WE ARE & WHAT WE MAKE

SRAM?

SRAM is the second largest bicycle component supplier in the world. Founded in 1988, SRAM's World Headquarters is located in Chicago, Illinois USA. Currently, SRAM has

manufacturing facilities in Ireland, Mexico, Taiwan, and with the purchase of Sachs Bicycle Component, also now has manufacturing in Germany, France, and Portugal.

GRIP SHIFT®

Twist shifters, designed to operate ESP and traditional actuation ratio derailleurs.



Rear derailleurs designed only to operate with ESP compatible GRIP SHIFT shifters.



Front and rear derailleurs designed to operate with Grip Shift twist shifters and other traditional actuation ratio shifters.



Cassettes and cranksets for a majority of applications.



Internal gear hub systems and leisure biking systems.



Brakes & levers for a majority of applications.



Hubs for a majority of applications.



Chains for all applications.

NEW IN 1999 / NAMING MATRIX

WHAT'S NEW FOR 1999?

- 9-speed shifters/rear derailleurs: 9.0SL, 9.0, 7.0 Plasma, Quarz, Neos
- 9-speed chains: PC59 and PC89R
- DI.R.T. Quarz/Neos front derailleur
- DI.R.T. Quarz/Neos rear derailleur
- MRX shifters: **completely redesigned**
- MRX IBS integrated brake shifter
- SRAM 9.0, 7.0 & 5.0 linear pull brakes
- Spectro internal hub systems

WHAT'S IMPROVED FOR 1999?

- New grip cover on the Grip Shift ESP 7.0 & 5.0 shifters and Grip Shift Centera shifter
- New gear indication on the Grip Shift ESP 5.0 shifter and Grip Shift Centera shifter
- New features for the SRAM 9.0 brake lever
 - Shorter reach
 - Smoother blade
 - Satin anodized hardware
- New features for the SRAM 7.0 brake lever
 - 2 position leverage adjust
 - Shorter reach
 - Smoother blade
 - Grey/black finish

EVOLUTION OF SRAM GRIP SHIFT SHIFTERS

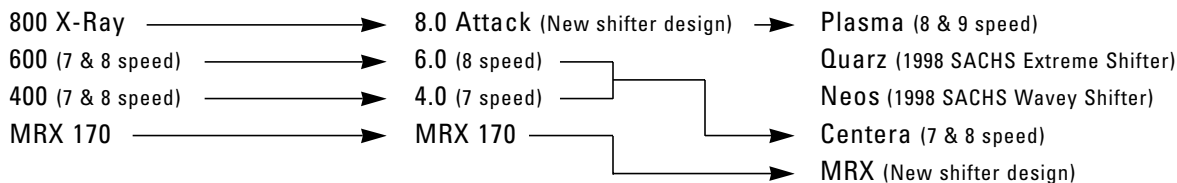

SRAM TECHNOLOGY

WHAT IS ESP?

ESP is SRAM's mountain specific rear derailleur technology.

• 1:1 ACTUATION RATIO

Other derailleurs have 1:2 actuation ratio – one inch of cable pull at the shifter, two inches of movement at the derailleur. **This multiplies any problems or poor adjustments at the shifter or with the cable system into twice the problem at the derailleur.**

A 1:2 system also requires higher cable tension. With an ESP rear derailleur, when your shifter pulls an inch of cable, the rear derailleur only moves an inch. This is achieved by a 'fin' on the derailleur outer link, **which efficiently spools cable as you shift gears.** With our 1:1 actuation ratio, you effectively have twice as long a lever arm as a 1:2 system giving you half the cable tension with spring. This means less cable friction between the shifter and the derailleur which translates to lower shifting effort and faster shifts.

• CONSTANT CHAIN GAP

Other rear derailleurs utilize a road bike design with an added longer cage. This design utilizes a b-spring where the derailleur mounts to the bike. The force in this b-spring must be balanced against the force in the idler cage spring along with the offset jockey wheel to achieve

constant chain gap. It is impossible to increase the stiffness of the idler cage spring without affecting chain gap because this overpowers the b-spring. Because the ESP Rear Derailleur is mountain bike specific, we got rid of the b-spring and fixed the angle of the slant parallelogram to mirror the profile of an MTB cassette. With this constant chain gap feature and no b-spring bounce in rough terrain, the ESP derailleur remains perfectly located for fast and precise shifts with less effort. It also makes possible the use of a much stronger idler cage spring for better control of chain slap and chain suck.

• NO FLOATING GUIDE PULLEY

The combined effects of constant chain gap and a 1:1 actuation ratio give the ESP rear derailleurs an inherent precision. This makes it unnecessary for the derailleur to have a floating guide pulley – once again resulting in faster and more positive shifts.

• POWER SPRING

There are two kinds of parallelogram actuating springs commonly found in rear derailleurs: extension springs and torsion springs. Both have advantages and disadvantages. The power spring concept combines the best characteristics of both while eliminating the

disadvantages. The result is nearly equal effective spring tension across the entire operating range of the rear derailleur. (Only ESP has it.)



WHAT IS GRIP SHIFT?



Grip Shift is the original twist shifter. (It allows you to shift a full range of gears in a single twist.). Nothing is faster or easier to use. Now that SRAM has bought Sachs, all twist shifters in SRAM's arsenal are "Grip Shift". Remember – only SRAM twisters are "Grip Shift"!



SRAM TECHNOLOGY



WHAT IS DI.R.T.?

DI.R.T. stands for Direct Response Technology. Its front cable pull routing provides lower shifting effort, more direct cable routing, and high performance. DI.R.T. derailleurs use a traditional actuation ratio and are compatible with Grip Shift & Shimano® shifters.



WHAT IS SACHS SPECTRO BY SRAM?

Spectro is the new name for Sachs famous internal geared hub products. The design focus for Spectro is maximum shifting comfort with minimum maintenance for recreational and city bikes. Spectro models includes:

- Spectro 3x7
- Spectro E12
- Spectro S7
- Spectro P5
- Spectro T3
- NEW! Spectro Combi
- NEW! Spectro Plus shifters
- NEW! Spectro Lux V6 Dynamo



WHAT IS SRAM COMPOSITE?

We've searched the globe and evaluated materials in order to find the right balance of strength, toughness, stiffness, and weight. Materials from companies like Dupont, the makers of super tough Zytel® and EMS of Switzerland, who produce specialty performance polymers like Grilon®. The result of our effort is the best possible materials for each application.

POWER LINK SECTION

Every chain is only as strong as its weakest link – traditionally this is the connecting link. In contrast, the Power Link connection is just as strong and durable as every other link in the chain. And it can be opened and closed as many times as you want without using tools.



SUPPORT

WORLDWIDE DISTRIBUTORS

UNITED STATES

Action Bicycle USA
217 Washington Avenue - A
Carlstadt, NJ, 07072
Ph: 800.284.2453

Brunswick Bicycles
2275 Half Day Road
Bannockburn, IL, 60015
Ph: 847.940.8777

Bicycle Tech International
3201 B Richards Lane
Sante Fe, NM, 87505
Ph: 800.558.8324

Diamondback
4030 Via Pescador
Camarillo, CA, 93012
Ph: 800.776.7641

Downeast Bicycle Specialists
Porter Road, P.O. Box 226
Fryeburg, ME, 04037
Ph: 800.242.1043

Euro-Asia Imports
3935 FootHill
La Crescenta, CA, 91214
Ph: 818.248.1814

Giant Bicycle, Inc.
737 Artesia Boulevard
Rancho Dominguez, CA, 90220
Ph: 800.874.4268

Great Northwest
2335 North West Savier
Portland, OR, 97210
Ph: 800.927.9242

Hans Johnsen Company
8901 Chancellor Row
Dallas, TX, 75247
Ph: 800.879.1515

The Hawley Company
One Hawley Drive
Lexington, SC, 29073
Ph: 800.822.1985

Island Cycle Supply
425 Washington Avenue North
Minneapolis, MN, 55401
Ph: 800.627.2453

J&B Importers, Inc.
P.O. Box 161859
Miami, FL, 33116
Ph: 800.666.5000

J&B Importers West, Inc.
P.O. Box 1248
Englewood, CO, 80150
Ph: 800.999.9228

J&B Importers Pacific, Inc.
P.O. Box 88808
Seattle, WA, 98138
Ph: 800.627.2453

KHS Inc., Distributor
1264 East Walnut Street
Carson, CA, 90746
Ph: 800.347.7854

The Merry Sales Company
1415 San Mateo Avenue
San Francisco, CA, 94080
Ph: 800.245.9959

Performance Cycle Products
22 South 6th Avenue
Mount Vernon, NY, 10550
Ph: 888.265.1876

Olympic Cycle Supply
5711 West Douglass Avenue
Milwaukee, WI, 53218
Ph: 800.236.8380

Quality Bicycle Products
6400 West 105th Street
Bloomington, MN, 55438
Ph: 800.346.0004

Quantum Bicycle & Fitness
400 Venture Court, Suite 101
Verona, WI, 53593
Ph: 800.545.1229

Quentin Distributors
845 Carol Court
Carol Stream, IL, 60188
Ph: 800.323.1741

Raleigh Bicycle Co., USA
22710 72nd Avenue South
Kent, WA, 98032
Ph: 800.222.5527

Riteway Products
2001 East Dyer
Santa Ana, CA, 92705
Ph: 800.869.9866

Schwinn Cycling and Fitness
1690 38th Street
Boulder, CO, 80301
Ph: 800.245.1649

Seattle Bike Supply
7620 South 192nd
Kent, WA, 98032
Ph: 800.283.2453

Security Bicycle
32 Intersection Street
Hempstead, NY, 11551
Ph: 800.645.2990

Sinclair Imports
2755 Highway 40

Verdi, NV, 89439
Ph: 800.654.8052

Trek Bicycle Corporation
801 West Madison
Waterloo, WI, 53594
Ph: 800.879.8735

United Bicycle Parts
691 Washington Street
Ashland, OR, 97520
Ph: 800.482.1984

Wilson Bicycle Sales
31157 Wiegman Road
Hayward, CA, 94544
Ph: 800.877.0077

World Wide Cycle Supply
100 D Executive Drive
Edgewood, NY, 11717
Ph: 800.330.2550

EUROPE

AUSTRIA

KTM Fahrrad GmbH
Harlochnerstrasse 13
5230 Mattighofen
Ph: +43 7742 409 132
Fx: +43 7742 409 126

BELGIUM

Transmission S.A.
Boulevard du Centenaire 4
1325 Dion-Valmont
Ph: +32 10 24 46 46
Fx: +32 10 24 47 77

CZECH REPUBLIC

vokolek import
rezlerova 308
10900 praha-petrovice
Ph: +420 2692 3399
Fx: +420 2692 3399

Zitny
Cesko-bratske nam. 133/ II
29301 Mlada Boleslav
Ph: +420 326 72 22 14
Fx: +420 326 72 22 14

DENMARK

Dan Agentur
Stationsvej 77
5792 Arslev
Ph: +45 65 99 24 11
Fx: +45 65 88 28 42

FINLAND

J. Syväranta Oy
Nervanderinkatu 5E 47 / PL 64
F-00101 Helsinki
Ph: +358 9 490 137
Fx: +358 9 493 890

FRANCE

SRAM France
Rue de la Bruiqueterie
80210 Chepy
Ph: +33 3 22 26 01 00
Fx: +33 3 22 26 01 03

M.I.C.M.O. Eurostar
16, Rue de Marcel Brunliere
44270 Machecoul
Ph: +33 2 40 78 24 00
Fx: +33 2 40 02 33 86

SUNN
Z.I. Quest
31800 St. Gaudens
Ph: +33 561 94 85 71
Fx: +33 561 94 85 72

GERMANY

Hartje
Deichstr. 120-122
27318 Hoya
Ph: +49 4251 8110
Fx: +49 4251 811249

Epple
Mittereschweg 1
87700 Memmingen
Ph: +49 8331 7510
Fx: +49 8331 75197

Bico
E. Wiener Bike parts
GZR
Rabeneick/Schlote
Trisport
Veloring
ZEG

WORLDWIDE DISTRIBUTORS

EUROPE (CONTINUED)

GREECE

Gatsoulis Imports
8, Thessalonikis Street
14342 New filadelfia-athens
Ph: +30 1 25 12 779
Fx: +30 1 25 33 960

HUNGARY

Biker Kft.
Gyepsor u. 1
1211 Budapest
Ph: +36 1278 1021
Fx: +36 1278 1023

ICELAND

Oerninn Hjol LTD.
P.O. Box 8036, Skeifan 11
Reykjavik
Ph: +354 1 88 98 92
Fx: +354 5 88 98 96

ITALY

A.M.G. S.r.l.
Via Piave 10
23871 Lomagna (LC)
Ph: +39 039 5 30 11 67
Fx: +39 039 9 22 02 70

NETHERLANDS

Koch Kleeberg B.V.
Postbus 1069, Dukdalfweg 25
1300 BB Almere
Ph: +31 36 532 05 04
Fx: +31 36 532 25 48

Vertex Cycle Systems

NORWAY

Stians Sport A.S.
Vollveien 13, Bygg D, POB 107
1324 Lysaker
Ph: +47 67 11 00 20
Fx: +47 67 11 00 42

POLAND

giant polska
ul. midgatowa 4
02-796warszawa
Ph: +48 22 645 1434
Fx: +48 22 645 1436

harfa-harryson
ul. kozanowska 38/7
54152 wroclaw
Ph: +48 71 72 15 70
Fx: +48 7 13 27 80 92

PORTUGAL

ciclo coimbroes
parca manuel da silva reis 122
4400 vila nova de gaia
Ph: +351 23 79 4461
Fx: +351 23 06 163

REP. OF IRELAND

Raleigh Ireland Limited
Raleigh House,
Kylemore Road
Dublin 10
Ph: +353 1 626 1333
Fx: +353 1 626 1770

SLOVENIA & CROATIA

Proloco Trade d.o.o.
Partizanska 4
64000 Kranj
Ph: +386 64 38 02 00
Fx: +386 64 38 02 022

SPAIN

Casa Masfererrer
Pol. Ind. Congost-Avda.
San Julian, S/N Apdo Correos 89
E- 08400 Granollers
Ph: +34 3 846 34 44
Fx: +34 3 846 53 55

Team Bike

SWEDEN

Vartex
Batterivägen 14
43232 Varberg
Ph: +46 340 850 80
Fx: +46 340 61 11 90

SWITZERLAND

Intercycle
Industriegebiet, Haldemattstr. 3
6210 Sursee
Ph: +41 41 92 66 55 11
Fx: +41 41 92 66 352

Amsler & CO AG
Lindenstraße 16
8245 Feuerthalen
Ph: +41 5 26 59 36 36
Fx: +41 5 26 59 16 90

U.K.

Raleigh P&A
Triumph Road
NG 72 DD Nottingham
Ph: +44 115 9420202
Fx: +44 115 9282044

Fisher
Unit 2, Haslemore Business Centre
Lincolnway off
Lincoln Road
EN 1 1TE Enfield, Middx
Ph: +44 181 8053088
Fx: +44 181 8058821

Chickens & Sons
Bisley Works/Landpark Lane
LU6 2PP Kensworth, Beds
Ph: +44 1582 873583
Fx: +44 1582 873583

AUSTRALIA

Groupe Sportif Pty. Ltd.
20 Harker Street
Burwood, Victoria 3125
Ph: +61.3.9888.9882

Velo-Vita Pty. Ltd.
Unit A, 602-612 Botany Road
NSW 2015 Alexandria
Ph: +61.2.9700.8177

CANADA

Bell Sports Canada
700 Chemin Bernard
Granby, PQ, J2G 9H7
Ph: 800.661.1662

Kempter Marketing
1271 St Louis
St Lazare, PQ, J7T 1Z9
Ph: 514.424.4600

Norco Products Limited
1465 Kebet Way
Port Coquitlam, BC, V3C 6L3
Ph: 800.663.8916

ISRAEL

Hobbys Ltd.
3 dov. Fridman street
52504 ramat gan
Ph: +972 5 2429 905
Fx: +972 3 7323 543

JAPAN

Kawashima Cycle Supply
No. 2-4-2 Kushiya-Cho Higashi
Sakai, Osaka 590
Ph: 0722.38.1557

Nichinao Shokai
6-16-8 Sotokanda Chiyodaka
Tokyo 101
Ph: 0338.32.6251

NEW ZEALAND

Cycle Supplies
PO Box 33051
Christchurch
Ph: +64.3.338.6803

H.S. White & Sons
7C Anwen Place, East Tamacki
PO Box 58331 Greemouni
Auckland
Ph: +64.9273.7690

SOUTH AFRICA

Adventure Sports Trading
27 Elizabeth Lane, North End
6001 Port Elizabeth
Ph: +27.41.547101

TECH SUPPORT & WARRANTY

WHO TO CALL

For fast SRAM dealer warranty and technical support help, please contact us at the appropriate locations listed hereafter. (Other Countries: please contact your local distributor.)

NORTH AMERICA

Dealer Helpdesk Number:

(800)-346-2928

EUROPE

Dealer Helpdesk Number for the following countries:

- Austria
- Belgium
- Denmark
- France
- Germany
- Italy
- The Netherlands
- Norway
- Sweden
- Switzerland
- United Kingdom

+ 800 / 77 26 43 57
SRAM HELP

SRAM 2 YEAR WARRANTY

In addition to standard legal warranty entitlements, SRAM components include a two year full warranty beginning on the date of purchase. This warranty is subject to the following conditions:

1. During the warranty period, SRAM components with material or production defects which as a result adversely affect the proper functioning of such components, shall either be repaired or replaced with a functioning SRAM component free of charge, whereby we are free to determine whether repair or replacement should take place. If a component cannot be replaced or repaired, the purchaser shall receive, free of charge, a component of higher value from the current SRAM product line. Defective components which have been replaced become the sole property of SRAM.
2. Any other warranty claims not included in this statement are void. This especially includes any disassembly or assembly costs (for instance by the dealer), which shall not be covered by SRAM.
3. Warranty claims are only valid upon presentation of a proper proof of purchase.
4. Parts subject to normal wear and tear (for example brake sleeves, brake pads, chains etc.) and damage which is caused by improper use, specifically caused by disregard for our assembly and operating instructions, shall not be covered by this warranty. Furthermore, this warranty shall not cover damages caused by the use of parts of different manufacturers or otherwise which are not compatible or suitable for use with SRAM components.
5. The servicing of a valid warranty claim shall neither extend this warranty nor establish a warranty period.
6. If a defect is discovered, please contact the dealer where the bicycle or the SRAM component in question was purchased.

TECHNICAL TIPS & GUIDELINES

INDEX SHIFTING OVERVIEW

AN EFFECTIVE SHIFTING SYSTEM

Index shifting has a single objective – one click of the shifter gets you one gear change. Accurate indexing depends on many things, but two are critical. One is the smooth interaction between the chain and cogset and the chain and chainrings. The other is getting the shifter ‘signal’ accurately to the derailleur. The signal tolerance is getting smaller as technologies advance (7 to 8 to 9 speeds) and styles change (various component manufacturers). Add to this the harsh effects of the riding environment – rain, mud, grit. An efficient shifting system achieves consistent, smooth, accurate shifts with minimal effort.

Component compatibility, proper setup and system cleanliness are essential to achieve a precision indexing system.

LINKAGE

CABLE & CABLE HOUSING

Getting a good signal from the shifter to the derailleur is enhanced by a precise cable connection between the two. The signal quality degrades with use and abuse. When shifting, pulling cable stretches the cable and compresses the cable housing; releasing cable decompresses the cable housing. This small change in the cable system can scramble the message from the shifter to the derailleur.

- Use only index compatible cable – flexible, smooth surface and corrosion resistant.
- Use 4.0 mm or 5.0 mm lined and capped compressionless cable housing – stiff, yet bends uniformly.
- Always route cables and cable housing as smoothly as possible.
- Use compressionless cable housing ferrules.

When riding in mountain biking conditions, water, mud and grit contaminate the cable housing sections. The most vulnerable section is the housing at the rear derailleur.

- **Replace** cable housing and clean or replace cable when dirty or when shifting effort becomes high.
- Use a **frictionless** seal.

SEALS

To help minimize and slow down the contamination it is advantageous to seal the rear derailleur cable housing section. Sealed ferrules are, unfortunately, points of resistance. A frictionless seal is optimal.



Nightcrawler seal

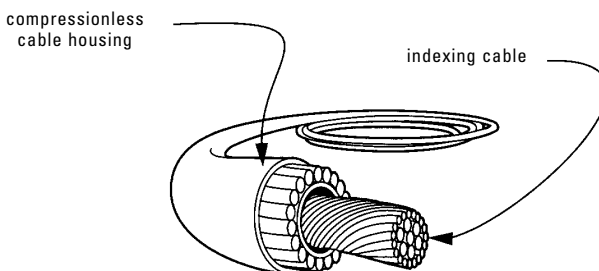

INDEX SHIFTING OVERVIEW

FRONT SHIFTING

Keys to accurate front shifting:

- clean, low friction index compatible cables and cable housing
- chain line between 47.5 and 50 mm
- matching front derailleur cage to chainwheel – compact with compact; full size with full size
- front derailleur gear teeth capacity (See Front Derailleur Installation section.)
- compatible chain for chainrings
- cable tension
- limit screw settings
- accurate front derailleur cage positioning and angle

REAR SHIFTING

Keys to accurate rear shifting:

- clean, low friction index compatible cables and cable housing
- rear derailleur hanger alignment and geometry
- rear derailleur total capacity (See Rear Derailleur Installation section.)
- compatible chain for cogset
- correct chain gap (See Rear Derailleur Installation section.)
- cable tension
- limit screw settings
- freely moving rear derailleur pivots and strong springs

CHAIN LINE

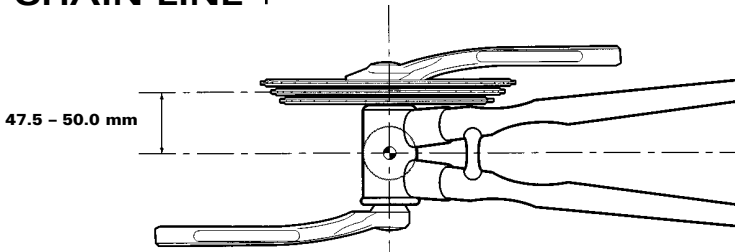

CHAIN LENGTH

Chain length will also affect indexing quality and shifting effort. See the Rear or Front Derailleur Installation section for proper chain length sizing.

TROUBLESHOOTING TIPS

A WORD ABOUT CONTAMINATION...

Contamination of shifter cable housing from water, mud and grit is by far your worst enemy.

- replace cable housing when dirty – do **not** try to clean it –
- clean and save (if possible) the cable when dirty; otherwise replace it
- **never** put a fresh cable into used cable housing

I CAN'T SHIFT TO SMALLEST COG...

- cable housing is contaminated; replace cable housing and clean or replace cable
- rear derailleur hanger misaligned; check with a derailleur hanger gauge.
- worn or contaminated rear derailleur pivots or spring
- incorrect limit screw adjustment (See derailleur instructions.)
- incorrect cable tension (See derailleur instructions.)
- incorrect chain gap (See derailleur instructions.)
- chain is incompatible with cogs
- worn chain, cogs, or pulleys
- D dimension is off

IT IS HARD TO TWIST SHIFTER...

- cable housing is contaminated; replace cable housing and clean or replace cable
- cable housing ferrules improperly seated or missing
- inner wire rubs against cable housing stop; try alternate routing
- cable housing not compressionless type
- cable routing has small, drastic bends or kinks – particularly the rear derailleur section try alternate routing or use **zip ties** to realign cable housing
- shifter cable clamped to wrong side of the

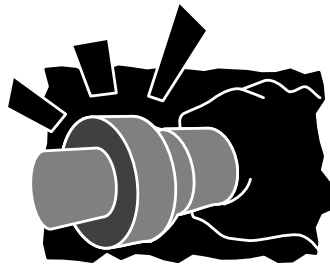

derailleur cable anchor bolt (See derailleur instructions.)

- wrong grease/lubricant or cleaner used in shifter; use only SRAM factory approved Jonnisnot grease
- shifter spring installed in the wrong direction (See shifter installation section.)
- no washer(s) between the shifter and the stationary grip
- shifter contaminated; properly clean and lube

MY FRONT SHIFTING IS OFF...

- cable housing is contaminated; replace cable housing and clean or replace cable
- chain line is off check that crank bolts are tight
- incorrect limit screw adjustment (See derailleur instructions.)
- incorrect cable tension (See derailleur instructions.)
- front derailleur position and/or angle are off (See derailleur instructions.)
- chain incompatible with chainrings
- front derailleur cage and chainrings do not match; compact with compact, full size with full size

LUBRICATION GUIDELINES

After proper cleaning of a component, relubricate the following key areas with Jonnisnot lube:

SHIFTER

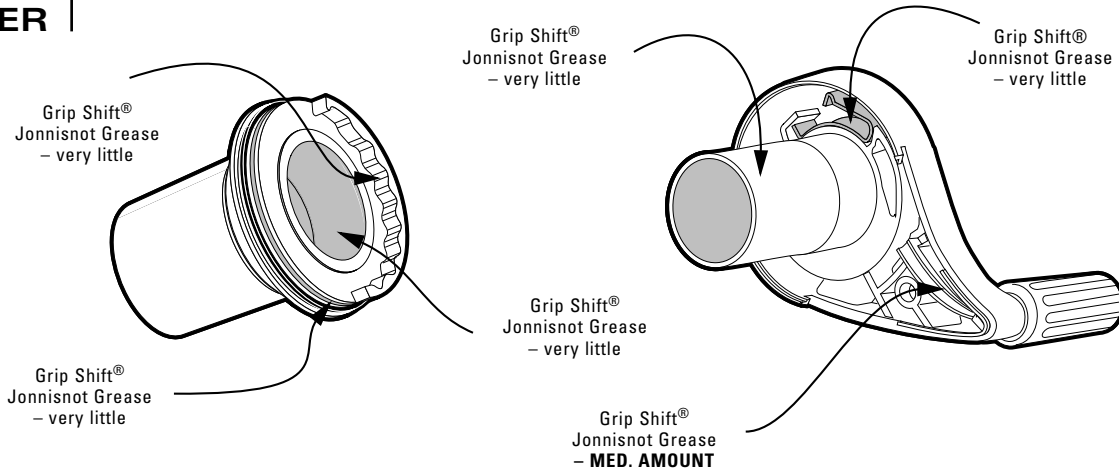

REAR DERAILLEUR

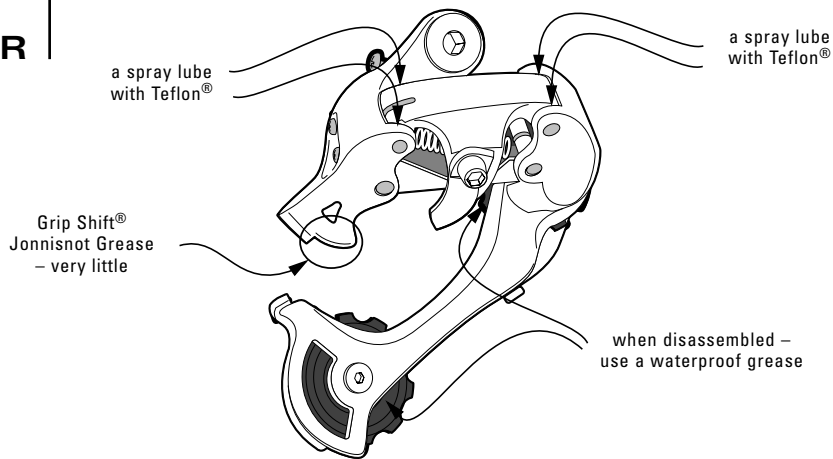

FRONT DERAILLEUR

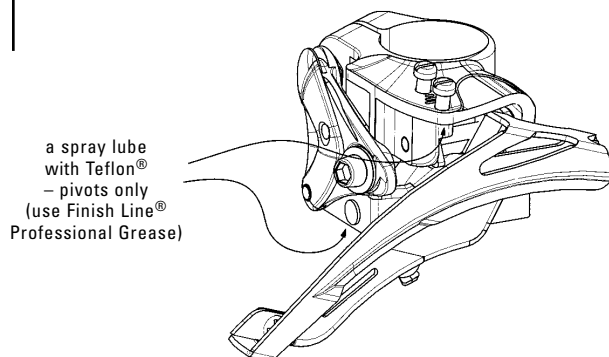

MAKE IT SHINE!

KEEPING YOUR BIKE CLEAN

Keeping your bike and components clean and correctly lubricated will keep performance high and usually slow down the wear and tear on parts.

HOW THE PROS DO IT

Wanna know how the pros do it? Use mild soap and water and a large sponge or soft brush to gently work off the mud and crud. Then rinse with a clean water sponge bath.

KEEP THE BIKE ON BOTH WHEELS

Always keep the bike on both wheels when cleaning with water. Hanging the bike vertically or upside down to hose it clean can lead to water drainage into now vulnerable components. Pay and spray? Avoid it.

CLEANING OF ESP AND GRIP SHIFT

We recommend that the internal cleaning and lubrication of Grip Shift shifters should only be done when shifting performance has deteriorated due to excessive contamination. We have found that, generally, the deterioration of shifting efficiency starts with the contamination of the cable and housing system. This causes high friction buildup in a shifting system and should be examined first.

THINK OF RE-LUBRICATING

After the cleaning of any component, always properly re-lubricate if required.

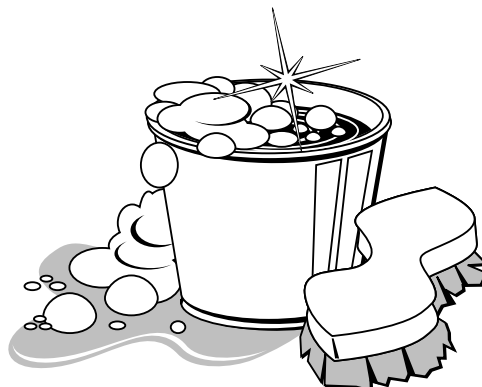

Caution:
Be careful how you use degreasers, citrus or otherwise, on your bike components. Degreasers can bloat, soften, or otherwise damage parts.

Quick rinses at the car wash or even spraying with a garden hose can drive contaminants past the **sealed** mechanisms of your components. This could compromise their performance and shorten their lifespan.

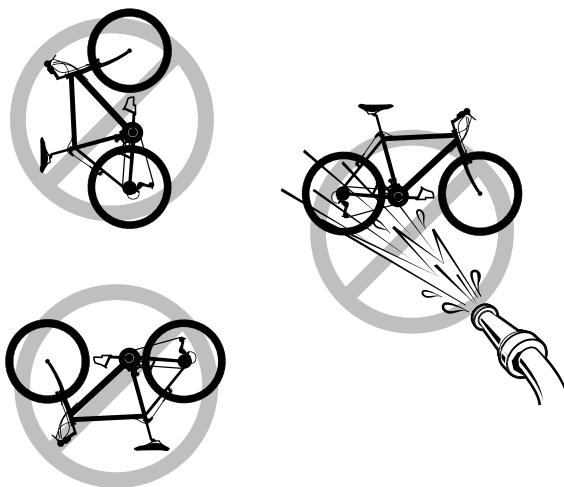

INSTRUCTIONS

ESP REAR DERAILLEUR INSTALLATION



1

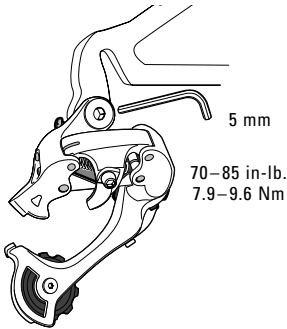

REAR DERAILLEUR ANATOMY

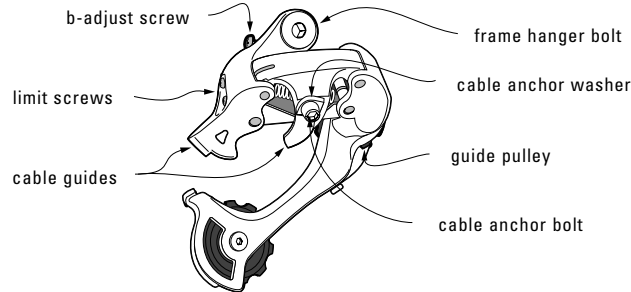

COMPATIBILITY

Shifters	SRAM® 5.0, 7.0, 9.0, 9.0SL shifters ONLY
Cogsets	7.0, 9.0, 9.0SL use 11-28, 11-30, 12-28, 12-32, 11-32 5.0 use 11-28, 11-30, 14-28
Chains	SRAM Power Chain and Shimano® HG & IG
Chainrings	22-32-42/44, 24-34-46, 26-36-46/48
Cable	1.1 or 1.2 mm high quality cable
Housing	4 or 5 mm compressionless cable housing

2

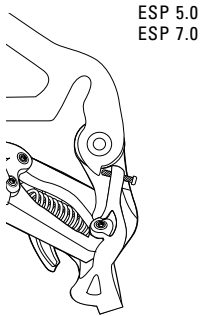

FRAME DIMENSIONS

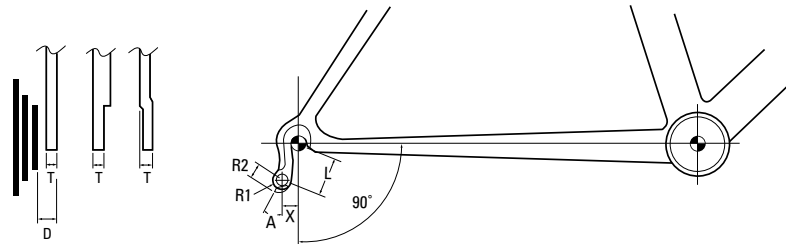

12.7 mm ± 1 mm

- For optimal ESP rear derailleur performance, the recommended rear derailleur hanger length (L) should be between 28–30 mm.
- For a given L, use the chart below to determine other ESP rear derailleur hanger specifications.

DIMENSIONS (mm, except A)

L	X	A	R1	R2	T
28	6–10	25°–30°	8.5 max	11.5–13.5	7–8
30	7.5–10	25°–30°	8.5 max	11.5–13.5	7–8

3

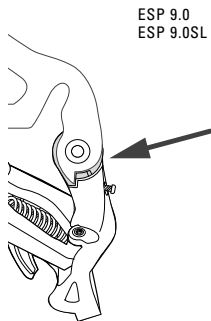

4

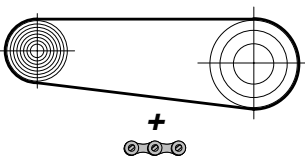

INSTALLATION

TIP:
Check the rear derailleur hanger alignment. A bent rear derailleur hanger will result in inaccurate index shifting. Outboard side impacts are the most common cause of this type of damage.

- Attach the rear derailleur to the frame rear derailleur hanger. (Fig. 1)

- Check that the b-adjust screw is clear of the rear derailleur dropout tab. (Fig. 2 or 3)
 - For 9.0, 9.0SL models, check that the b-adjust washer is properly oriented. The b-adjust washer allows for a more accurate chain gap adjustment. (Fig. 3)
- Tighten the 5 mm hex hanger bolt to 70–85 in-lb. (7.9–9.6 Nm).

ESP REAR DERAILLEUR INSTALLATION

5

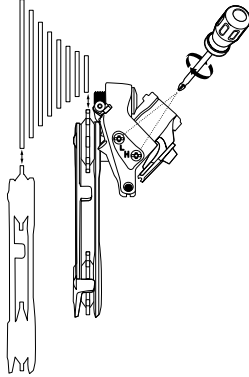

CHAIN LENGTH

When the chain is in the largest chainring/largest cog combination, a very tight chain or chain seizure can occur. Therefore, it is important to have a properly sized chain length.

1. Bypassing the rear derailleur, run the chain around the largest chainring/largest cog combination. (Fig. 4)
 - For a rear suspension frame, position the rear suspension for the greatest chain length required.
2. Add 2 LINKS of chain to this length for proper chain length.

LIMIT SCREWS ADJUSTMENT

1. View the rear derailleur and pulleys from behind the rear wheel.
2. Align the guide pulley center with the outboard edge of the smallest cog, using a small screwdriver to turn the 'H' (BOTTOM) limit screw. (Fig. 5)
3. While turning the crankset, push the rear derailleur inboard by hand.
4. Align the guide pulley with the largest cog, center to center, using a small screwdriver to turn the 'L' (TOP) limit screw. (Fig. 5)

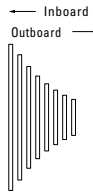

- For the 'H' limit screw – clockwise moves the guide pulley inboard.
- For the 'L' limit screw – clockwise moves the guide pulley outboard.

CHAIN GAP ADJUSTMENT

Chain gap is the distance, along the chain, between the chain contact with a cog and the chain contact with the guide pulley. Optimal chain gap is small enough to allow quick, efficient shifts to and from any cog; large enough to allow smooth shifts to and from the largest cog.

1. While turning the crankset, push the rear derailleur inboard by hand to the largest cog.
2. Hold the rear derailleur in this position while making the following adjustment.
3. Use a 3 mm hex wrench to turn the b-adjust screw until the chain gap equals 1 1/2 LINKS. (Fig. 6)

- Turn the b-adjust screw clockwise to increase chain gap.
- Turn the b-adjust screw counterclockwise to decrease chain gap.

TIP:

It is not recommended to use the b-adjust screw to tension the rear derailleur to prevent "chain suck". This only opens the chain gap and compromises shifting efficiency.

INDEX SHIFTING ADJUSTMENT

1. Check that the chain and the rear derailleur are in the smallest cog position.
2. Rotate the rear shifter so the highest gear indication mark lines up with the dash mark.
3. Turn the rear shifter barrel adjuster clockwise fully into the shifter, then back off one full turn.
4. Feed the rear shifter cable through the rear derailleur cable housing, stops, and rear derailleur cable guides.
5. Pull the cable taut around the curved cable guide and position it under the cable anchor washer. (Fig. 7)
6. Tighten the 5 mm hex cable anchor bolt to 35–45 in-lb. (3.9–5.0 N-m).
 - Be careful not to crush or deform the cable.

TIP:

A unique feature of ESP rear derailleurs is the low cable tension necessary for proper indexing. Be sure not to over tension the cable when attaching it to the rear derailleur.

7. Rapidly shift the chain up and down the cogset several times.
 - If the cable slips, see steps 5–6.
8. Shift the chain to the smallest cog.
9. Shift one detent to the second cog.
 - If the chain hesitates or does not shift to the second cog, increase the cable tension by turning the shifter barrel adjuster counterclockwise.
 - If the chain shifts beyond the second cog, decrease the cable tension by turning the shifter barrel adjuster clockwise.
10. Repeat steps 8–9 until the cable tension is accurate.
11. While turning the crankset, shift the chain up and down the cogset several times.
 - Check for smooth, efficient indexing to each gear.

TIP:

Cable and housing components will settle under compression. It may be necessary to readjust the rear derailleur cable tension using the shifter barrel adjuster after an initial "break-in" period.

6

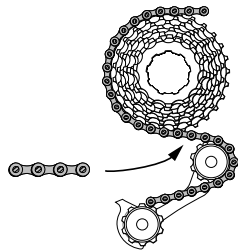

7

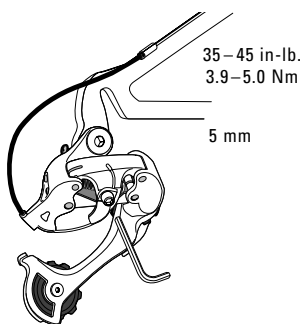

DI.R.T. REAR DERAILLEUR INSTALLATION



TECHNICAL SPECIFICATIONS

		Plasma	Quarz	Neos	Centera
Index/Friction		index	index	index	index
Max. No. of speeds		9	9	9	9
Long cage (L)	Total capacity	40 T	40 T	40 T	40 T
	Max. sprockets	32 T	32 T	32 T	32 T
	Min. sprockets	11 T	11 T	11 T	11 T
Adjustable derailleur pivot angle		X	X	X	X
Direct mount		X	X	X	X

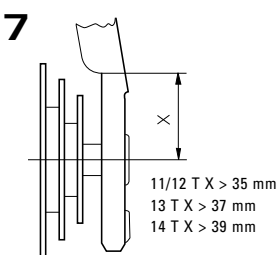
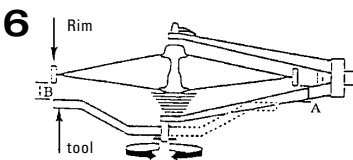
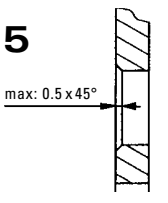
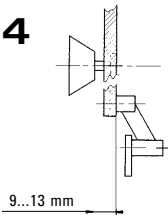
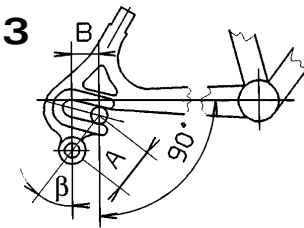
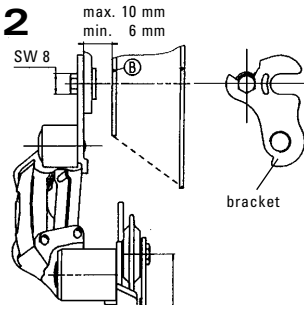
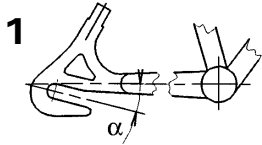

ASSEMBLY REQUIREMENTS, FRAME DIMENSIONS

Mounting with rear derailleur bracket:

- The angle (a) between the dropout and the centerline of the chainstay must be in the range of min. 20° and max. 30° (Fig. 1).
- If the maximum dimension of 10° is exceeded between the smallest sprocket and the outer side of dropout, a rear derailleur with an offset bracket must be used (Reference No. 1120 441 020) (Fig. 2).

Direct mount:

- Important dimensions for rear dropout with integrated derailleur hangers are shown in Fig. 3 and in the following table.

β	A	B	
25°-30°	25	max. 10	Road
25°-30°	26...30	6 -10	MTB

- The distance between the smallest sprocket and the derailleur contacting surface must not exceed 9 to 13 mm. (Fig. 4)
- On the dropout, the hanger to which the rear derailleur is attached may have a max. chamfer of 0.5 x 45°. The contacting surface for the rear derailleur must be completely level. (Fig. 5)
- Dropouts which are opened towards the bottom are more reliable.

Direction of dropout:

- The differential between point A and point B must not exceed 10 mm. (Fig. 6)

Geometry of rear dropout:

- The geometry of the seat stay and rear fork depends on the smallest sprocket used. (Fig. 7)

Outer stops for cable housings:

- The inner diameter of the outer stop must be a minimum of 6.05 mm. (Fig. 8)

System components / Accessories

- Direct mount:** When the thickness of the frame dropout is ≤ 5.5 mm: use **washer with reference number 1118 401 071** (Fig. 9).
- Mounting with bracket:** If the maximum dimension of "10" is exceeded between the smallest sprocket and the outer side of the

dropout, a derailleur with an **offset bracket** (with reference number 1120 441 020) must be used. (Fig. 10)

COMPATIBLE ROTATIONAL SHIFTERS

Grip Shift

Plasma	8, 9 speeds
Quarz	8, 9 speeds
Neos	7, 8 speeds
Centera	7, 8 speeds
MRX	6, 7 speeds
Bandix	5, 6, 7 speeds

Di.R.T. rear and front derailleurs are Shimano® compatible

To mount the SRAM shifters, please refer to the Fitting Instructions and User's Manual No. 1168 107 001

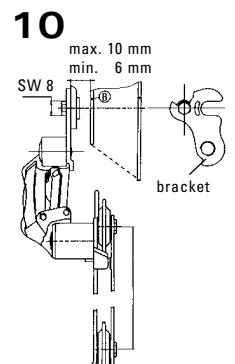
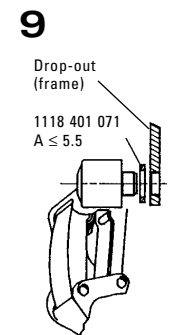
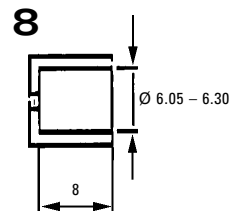
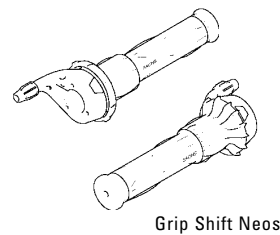

DI.R.T. REAR DERAILLEUR INSTALLATION

11

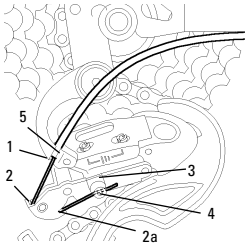

LENGTH OF CABLE HOUSINGS / DI.R.T. REAR DERAILLEURS

Caution:
With this system, it is imperative to respect the following values for the correct length of cable housing. (See corresponding tables across)

- a) Example:
Distance **X** = 100 mm – here, cable housings measuring between 150 mm and 175 mm may be used.
- b) Example:
Distance **Y** = 150 mm – here, cable housings measuring between 200 mm and 210 mm may be used.

a) Mounting onto chainstay

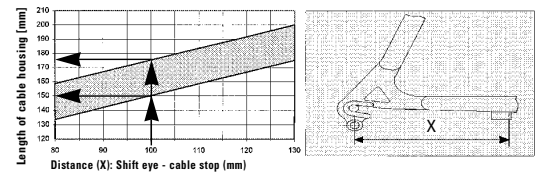

b) Mounting onto seat stay

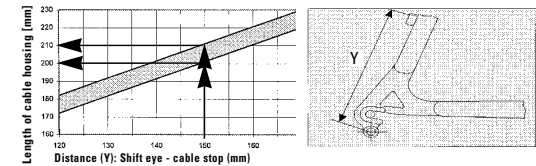

12

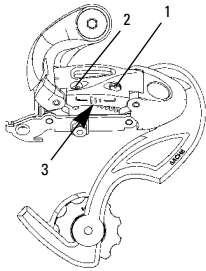

Caution:
When replacing cable housings, make sure to only use shifter cable housings measuring the same lengths.

13

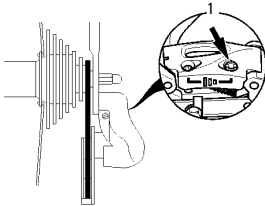

INSTALLATION / ADJUSTMENT / REMOVAL & ASSEMBLY OF DI.R.T. REAR DERAILLEURS

Installation:

- Fasten rear derailleur to frame dropout – with direct mount, use a 5 mm or 6 mm allen key, and a tightening torque of 8–10 Nm. When fitting with a bracket, use an 8 mm wrench and a tightening torque of 4–5 Nm.

smallest and the largest sprocket). Screw 1 refers to the high gear limit screw and screw 2 refers to the low gear limit screw. (Fig. 12)

- Move the guide pulley beneath the smallest sprocket (hold in place) and adjust the high gear limit screw (1) until the pulley is aligned directly below the smallest sprocket (Fig. 13).
- Move the guide pulley beneath the largest sprocket (hold in place) and adjust the gear limit screw (2) until the pulley is aligned directly below the largest sprocket (Fig. 14).

14

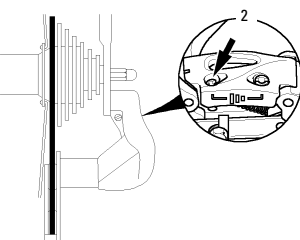

Connecting the shift cable (also applies when replacing shift cable; Fig. 11):

- Put the righthand shifter in highest gear position.
- Guide the shift cable through slot 1, thread through cable recess 2 of the cable cam (cable must run inside the "finger" 2a). Place the cable in the groove of the clamping plate 3, tighten and clamp in place with the cable clamp nut 4. Use an 8 mm hex key or a 5 mm allen key-tightening torque 5–6 Nm (53–60 in.lbs.). Make sure cable housing is well positioned in cable stop 5 of derailleur. (Fig. 11)

Caution:

Di.R.T. rear derailleurs incorporate a two spring design. The omission of the upper pivot spring has several functional advantages but does require precise adjustment of the angle adjustment screw (4, Fig. 15).

15

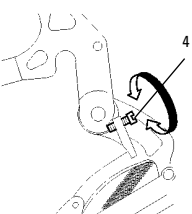

Mounting chain:

- Determining chain length: place chain on largest front chainwheel and on largest rear sprocket then add two chain links. Close chain.

Adjustment (for preadjustment)

- Screws 1 and 2 are used for presetting (symbols 3 engraved in the outer link designate the corresponding bolt for the

DI.R.T. REAR DERAILLEUR INSTALLATION

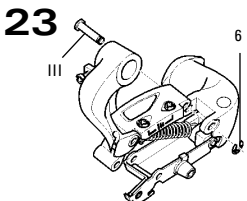
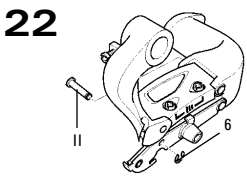
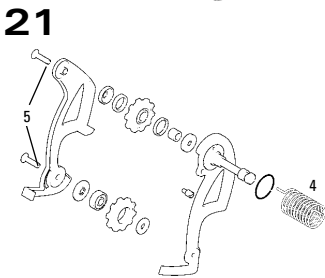
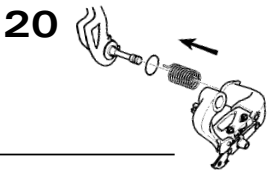
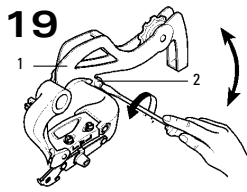
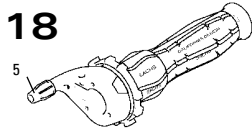
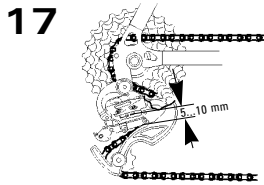
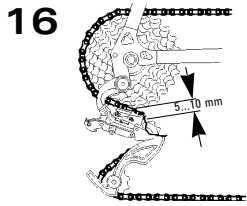

Adjustment requirements:

- For a cassette with a low gear (largest) sprocket of **30 or 32 teeth**, the clearance between the tooth tip of the guide pulley and the tooth tip of the low gear (**largest**) sprocket must equal **5–10 mm (Fig. 16)**.
- For a cassette with a low gear sprocket of **28 teeth** or less, the clearance between the tooth tip of the guide pulley and the tooth tip of the 11 T or 12 T sprocket must be **5–10 mm (Fig. 17)**.

Final adjustment (cable tension adjustment with shifter adjusting barrel):

- Place the right shifter in the highest gear. This corresponds to the chain being on the smallest sprocket.
- Rotate the crank. If the chain already scrapes against the second sprocket or changes onto it, turn the setting screw (**5, Fig. 18**) clockwise until the scraping noise stops and/or the chain changes back to the smallest sprocket.
- Change into the next gear using the shifter, rotating the crank in the drive direction.
- If the chain does not move to the next sprocket turn adjusting barrel (5) counter-clockwise (**Fig. 18**), to tension the control cable until the chain changes smoothly onto the second sprocket.
- Shift through gears several times and make any necessary adjustments.

DISASSEMBLY & REASSEMBLY

(Complete disassembly is only possible with the Plasma rear derailleur)

Completely dismantling cage:

- Dismount cage 1, to do so turn cage counterclockwise against spring until bolt 2 becomes accessible. Unscrew stop screw (**Fig. 19**) and turn cage clockwise into a vertical position. This is the only position in which one can remove cage 1 with O-Ring 3 (seated relatively snug around cage) and spring 4 from the lower body. (**Fig. 20**)

Disassembling and reassembling cage:

- After loosening the two bolts 5 in fig. 21, disassemble cage entirely into individual parts. Clean and eventually replace defective or worn parts. Before reassembling, lightly grease all bearing areas and spring 4. The position and assembly direction of the individual parts should correspond to the following illustration (**Fig. 21**).
- Tighten fastening bolts 5 with a torque of 2.5–3.5 Nm. (We recommend the use of a safety device such as Loctite).

Disassembling parallelogram:

- Remove washer 6 from axle II and slide axle out. (**Fig. 22**)
- Remove washer 6 from axle III and slide axle out. (**Fig. 23**)
- Unscrew axle I with a 2.5 mm allen key and remove outer parallelogram arm 7 (**Fig. 24**).

- Remove washer 6 from axle IV, slide axle out and remove spring 8. (**Fig. 25**)

Caution:

Before reassembly, clean all parts and lightly grease bearing areas and axles. Replace all defective or worn out parts.

Reassembling parallelogram:

- Slide axle IV halfway through inner parallelogram arm 9 and lower body 10. Place guide spring 8 in the slot and slide axle through completely. Mount washer 6. (**Fig. 26**)
- Slide axle I halfway through outer parallelogram arm 7 and upper body 11. Place spring in the slot and slide axle through completely. Tighten with a 2.5 mm allen key, a maximum of 1 Nm. (**Fig. 27**)
- Link outer parallelogram arm 7 and lower body with axle III. Mount washer 6. (**Fig. 28**)
- Mount axle II and add safety washer. (**Fig. 29**)

Fitting pre-mounted cage:

- Place spring 4 in body and keep turning until you feel spring end snap into bore which has been specifically designed for it.
- Insert cage 1 with O-ring 3 in such a way as to make sure that spring end is seated in bore 4a. (**Fig. 30**)
- Push cage against body and turn counterclockwise to the "12 O'clock position". This is the only position in which the cage's axle will completely slide in. (**Fig. 31**)
- Keep tightening cage counterclockwise until you are able to place stop screw 2. Torque: 1 Nm. (**Fig. 32**)

MAINTENANCE / CARE

- Do not use solvents or corrosive materials to clean the components.
- Oil the shifting joints regularly.
- Grease any cable guides (e.g. beneath the bottom bracket).

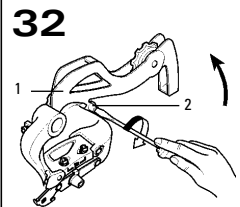
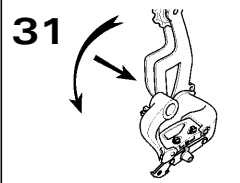
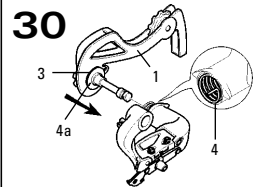
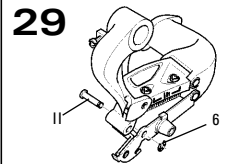
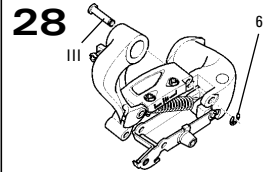
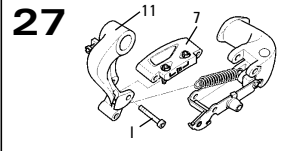
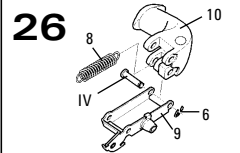
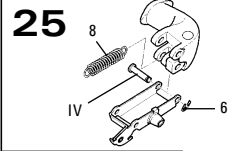
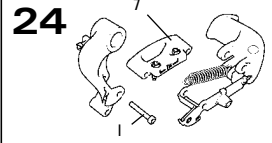

ESP & DI.R.T. FRONT DERAILLEUR INSTALLATION

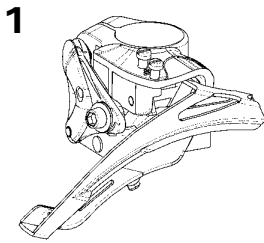

Integrated resin clamp, "Snap on" type

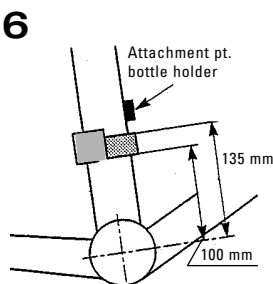
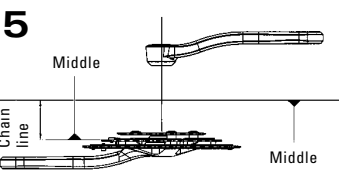
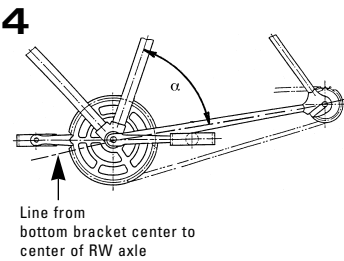
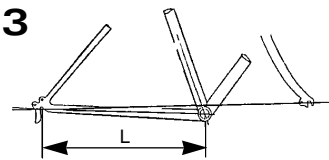
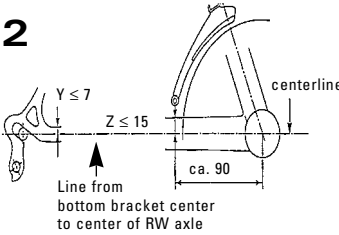

TECHNICAL SPECIFICATIONS

	QUARZ ESP 9.0	NEOS ESP 7.0	CENTERA ESP 5.0	
Clamp model	Snap on type	X	X	X
Clamp Ø	28.6	X	X	X
	31.8	X	X	X
	34.8	X	X	X
Guide deflection				
Functions as Top + Bottom = Twin pull	X	X	X	
Compact drive	Total capacity	22 T	22 T	22 T
	Max. No. of teeth	46 T	44 T	44 T
	Min. No. of teeth	20 T	20 T	20 T
	Min. diff. between large and middle chainring	10 T	8 T	8 T

ASSEMBLY REQUIREMENTS, FRAME DIMENSIONS

On traditional (non elevated) lower chainstays, the measurement Z should generally not exceed the value indicated in the following illustration. This will guarantee proper functioning of chain with dynamic chain angles. The seat tube should be positioned in the center of the bottom bracket shell (Fig. 2).

- Length of chainstay:**
- MTB/Trekking L > 420 mm (Fig. 3)
 - Rear frame alignment must be symmetrical.

Chainstay angle (Fig. 4)

Version 1
a = 63°...66°

Version 2
a = 66°...69°

Chainline: (Fig. 5)

Chainline = measurement from the center of the middle bracket to the center of middle chainring
47.5...50 mm

Necessary clearance for the DI.R.T. front derailleur

- Attachment of bottle holder (Fig. 6)
- Clearance between seat tube and mudguard or tire. (Striped area, Fig. 7)

COMPATIBLE ROTATIONAL SHIFTERS

Grip Shift

- Plasma
- Quarz
- Neos
- Centera
- MRX
- Bandix

Di.R.T. front derailleurs are Shimano® compatible.

To mount the SRAM shifters, please refer to the Fitting instructions and User's manual No. 1168 107 001.

FITTING / ASSEMBLING

Fitting:

Open the clamp gently and applying a slight pressure, clip it onto the frame tubing. (Fig. 8)

Caution!

When fitting, do not open the clamp too far – as it may break. (Fig. 9)

Maximum width of opening "X" (Fig. 10).

Tube Ø (mm)	max. X (mm)
28.6 + 5	34.0
31.8 + 5	37.0
34.8 + 5	40.0

- Align the front derailleur on the seat tube and tighten lightly.

Important:

For optimum gear change, there must be a clearance of 1–3 mm between the head of the teeth on the large chainring and the lower edge of the outer cage plate (4). The outer cage plate (4) must be parallel to the chainrings (Fig. 11).

- Tighten clamping bolt (3, Fig. 12) to a torque of 4.5 Nm (40 in.lbs) (Allen key 5 mm).

Setting low gear limits: (Fig. 12)

- Place the chain on the largest sprocket and the smallest chainring.
- Adjust the high gear limit screw (1) so that the chain is positioned close to the inner cage plate (5) without actually touching it.

Note:

The symbols (6) between the high and low limit screws (1, 2) show which limit screw belongs to which chainring.

Connecting the shift cable

(for example after changing the cable)

- Top Pull (Fig. 13)
 - Place the shifter in the corresponding end position.
 - Guide shift cable (1), coming from above, behind guide lug X between the clamping washers (2).

ESP & D.I.R.T. FRONT DERAILLEUR INSTALLATION

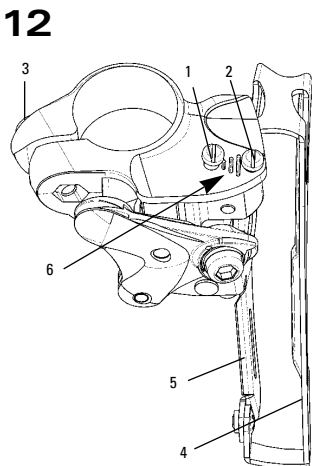
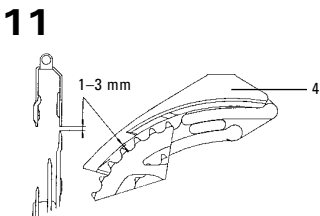
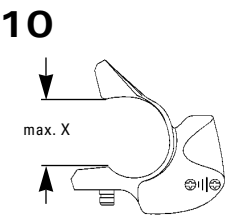
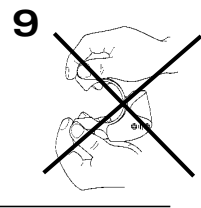
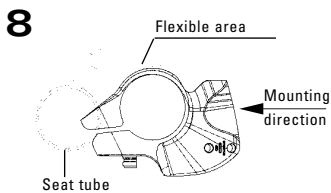
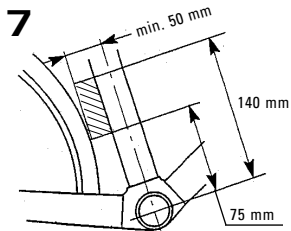

- Tension cable (3) in the direction of the arrow and tighten clamping bolt (4). Allen key 5 mm – tightening torque 4–5 Nm (45–53 in.lbs) (Fig. 13).

b) Bottom Pull (Fig. 14)

- Place the cable (1), coming from below, in guide groove (5) on the Twin Pull cable cam and route through the clamping washers (2).
- Tension cable (3) in the direction of the arrow and tighten clamping bolt (4). Allen key 5 mm – tightening torque 4–5 Nm (45–53 in.lbs).

Setting high gear limits: (Fig. 15)

- Shift the chain onto the smallest sprocket and the largest chainring.
- If the chain fails to shift onto the largest chainring, adjust the limit screw (2) accordingly. The chain must not scrape against the outer cage plate (4) and must not be thrown off the chainring.

Final adjustment (tensioning the cable)

Shift the chain onto the smallest sprocket and middle chainring – if the chain scrapes against the outer cage plate (4, Fig. 15), turn the adjusting barrel (7, Fig. 16) on the shifter counter-clockwise until the chain shifts smoothly and free of obstruction.

- Shift the chain onto the largest chainring – if the chain scrapes against the inner cage plate, turn the adjusting barrel on the shifter clockwise until the chain shifts smoothly and free of obstruction (Fig. 16).

Function test

- Shift through gears several times and adjust as necessary.

MAINTENANCE / CARE / SAFETY

Front Derailleur:

- Do not use solvents or corrosive materials to clean the components.
- Oil the shifting joints regularly.
- Grease any cable guides (e.g. beneath the bottom bracket).

Sachs rotational shifters:

- All shifters are equipped with an adequate supply of grease and are practically maintenance-free.

CAUTION! Warning:

- Fixed grips (left and right) take on an axial securing function and must be assembled so that they cannot slip off the handlebar.
- Never fit fixed grips using greasy or soapy solutions.
- Never ride without fixed grips, the turning part can work its way out of the housing and slip from the handlebar – this could lead to the rider falling and being injured.

Chain:

- Clean and lightly oil the chain as required.
- Do not wash out the chain or immerse it in water.
- Chain links must always move freely and unhindered.

CAUTION! Warning:

- When fitting the chain, follow the instructions of the chain manufacturer – incorrect assembly can lead to malfunctions or cause the rider to fall and be injured.

13

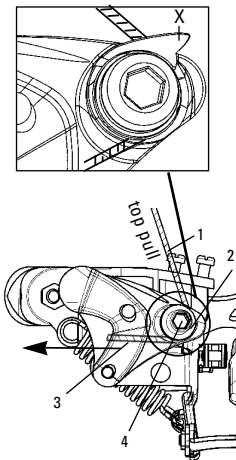

14

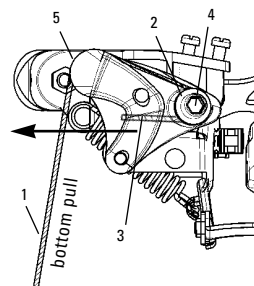

15

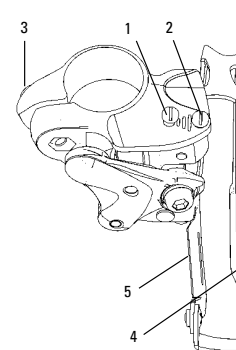

16

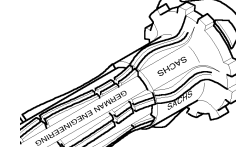

TROUBLESHOOTING GUIDE

REAR & FRONT DERAILLEUR

REAR DERAILLEUR

No.	Fault	Cause	Remedy
1	Chain jumps from smallest sprocket to frame dropout	<ul style="list-style-type: none"> High gear limit screw (1) is not adjusted properly 	<ul style="list-style-type: none"> Turn in screw (1, Fig. 12) until the guide pulley is aligned with the smallest sprocket
2	Difficult or impossible to shift chain onto smallest sprocket	<ul style="list-style-type: none"> High gear limit screw (1) is not adjusted properly 	<ul style="list-style-type: none"> Unscrew screw (1, Fig. 12) until the guide pulley is aligned with the smallest sprocket
3	Chain jumps over largest sprocket and falls between the spokes and largest sprocket or inner cage plate scrapes on spokes	<ul style="list-style-type: none"> Low gear limit screw (2) is not adjusted properly 	<ul style="list-style-type: none"> Turn in screw (2, Fig. 12) until the guide pulley is aligned with the largest sprocket
		<ul style="list-style-type: none"> Rear derailleur or derailleur hanger is bent 	<ul style="list-style-type: none"> Straighten or replace.
4	Delayed shifting	<ul style="list-style-type: none"> Clearance between guide pulley/sprocket is too large 	<ul style="list-style-type: none"> Adjust angle adjusting screw by rotating counterclockwise (4, Fig. 15)
5	Rough shifting behavior	<ul style="list-style-type: none"> Clearance between guide pulley/sprocket is too small 	<ul style="list-style-type: none"> Adjust angle adjusting screw by rotating clockwise (4, Fig. 15)
6	Chain jumps two gears on small sprocket	<ul style="list-style-type: none"> Shift cable insufficiently tensioned 	<ul style="list-style-type: none"> Turn barrel adjuster (5, Fig. 18) on the shifter counterclockwise
7	Delayed shifting onto larger sprocket	<ul style="list-style-type: none"> Shift cable insufficiently tensioned 	<ul style="list-style-type: none"> Turn barrel adjuster (5, Fig. 18) on the shifter counterclockwise
8	Delayed shifting onto smaller sprocket	<ul style="list-style-type: none"> Shift cable is too tense 	<ul style="list-style-type: none"> Turn barrel adjuster (5, Fig. 18) on the shifter clockwise
		<ul style="list-style-type: none"> Excessive cable/housing friction 	<ul style="list-style-type: none"> Lubricate or replace cable and housing

FRONT DERAILLEUR

No.	Fault	Cause	Remedy
1	Shifter actuated, chain fails to change chainring	<ul style="list-style-type: none"> Shift cable incorrectly clamped 	<ul style="list-style-type: none"> Check shift cable and correct as necessary (cable clamp; cable housing stops; cable recess in shifter; cable tension)
		<ul style="list-style-type: none"> High/low limit screw poorly adjusted 	<ul style="list-style-type: none"> Correct as described under fitting, Fig. 12/15
		<ul style="list-style-type: none"> Clearance between cage and large chainring is too big/small (spec. 1–3 mm, compare Fig. 11) 	<ul style="list-style-type: none"> Correct as described under fitting
2	Chain falls over large/small chainring	<ul style="list-style-type: none"> High / low limit screw poorly adjusted 	<ul style="list-style-type: none"> Correct as described under fitting, Fig. 12/15
3	Chain is on middle chainring and scrapes against the cage when the largest or smallest sprocket is selected	<ul style="list-style-type: none"> Precise adjustment of cable tension is incorrect 	<ul style="list-style-type: none"> Readjust as described under fitting, "Final adjustment", Fig. 15/16
4	Force required to actuate gears is too high	<ul style="list-style-type: none"> Excessive cable friction 	<ul style="list-style-type: none"> Lubricate or replace cable and housing
5	Front derailleur collides with crank	<ul style="list-style-type: none"> High gear limit screw (2) incorrectly adjusted 	<ul style="list-style-type: none"> Correct as described under fitting, "Setting high gear limits", Fig. 12/15
		<ul style="list-style-type: none"> Use of a crankset which is incompatible with SRAM front derailleurs 	<ul style="list-style-type: none"> Use compatible crankset
		<ul style="list-style-type: none"> Cage not parallel with chainring 	<ul style="list-style-type: none"> Correct the front derailleur position as described under fitting, Fig. 11

SHIFTER INSTRUCTIONS

ESP 9.0SL, 9.0, 7.0, PLASMA™

1

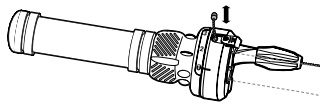

SHIFTER ANATOMY

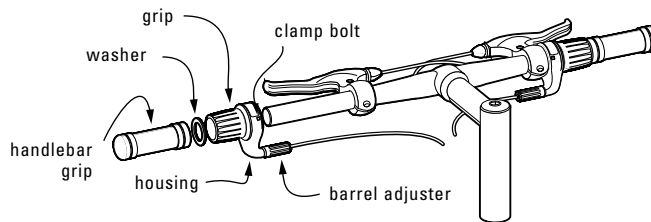

2

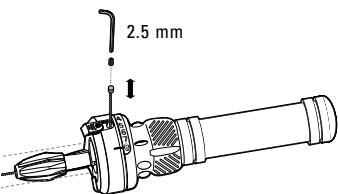

INSTALLATION

FRONT and REAR:

- Slide the front (rear) shifter onto the left (right) side of the handlebar.
 - If necessary, move the brake lever to allow for the shifter and the handlebar grip.
 - Bar end users – don't forget to leave room for the bar end.
- Rotate the shifter until the barrel adjuster is beneath (but out of the way of) the brake lever.
- Tighten the 3 mm hex clamp bolt to 17 in-lb. (1.9 Nm).
- Slide the plastic washer onto the handlebar.
 - The washer prevents the handlebar grip from interfering with the shifter rotation.
- Slide the handlebar grip onto the handlebar.
 - Solvents, lubricants or hair spray may damage the handlebar grips!**
 - Use **only** compressed air or water to aid installation.
- Feed the cable through the cable housing and stops.
- Attach the front (rear) shifter cable to the front (rear) derailleur.
- Adjust indexing per the derailleur instructions.

- Remove and discard the rest of the old cable.
- Feed the new cable through the cable entry and out the barrel adjuster.
- Pull the cable snug.
- Replace the escape hatch.
- Feed the cable through the new cable housing and stops.
- Attach the cable to the front derailleur and adjust indexing per the derailleur instructions.

REAR (Fig. 2)

- Detach the cable from the rear derailleur.
- Cut the cable off 6" from the shifter barrel adjuster. Discard the old cable and cable housing.
- Remove the escape hatch.
- Rotate the shifter so the indicator mark is aligned with the highlighted number.
 - Look for the cable entry.
- Remove the 2.5 mm hex cable retention screw.
- Remove and discard the rest of the old cable.
- Feed the new cable through the cable entry and out the barrel adjuster. Pull the cable snug.
- Replace the cable retention screw – be sure to turn until the screw contacts the cable head.
- Replace the escape hatch.
- Feed the cable through the new cable housing and stops.
- Attach the cable to the rear derailleur and adjust indexing per the derailleur instructions.

Hey again!

- Clean all shifter parts using **ONLY** water and mild soap.
- Use **ONLY** Grip Shift Jonnisnot Grease for any shifter lubrication.

3

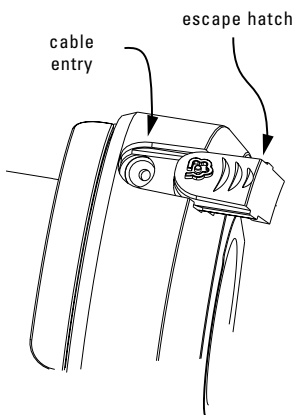

Attention!

- Always check the front and rear brake levers for proper operation.
- If there is interference between a shifter and a brake lever, rotate one out of the way. Check for proper brake lever operation again!

CABLE CHANGE

Check this out:

- Leave the shifter on the handlebar.
- No need to move other components – **THE SHIFTER DOES NOT NEED TO BE OPENED.**
- Use only new, high quality cable and compressionless cable housing.

FRONT (Fig. 1)

- Detach the cable from the front derailleur.
- Cut the cable off 6" from the shifter barrel adjuster. Discard the old cable and cable housing.
- Remove the escape hatch.
- Rotate the shifter so the indicator mark is aligned with the highlighted number.
 - Look for the cable entry.

4

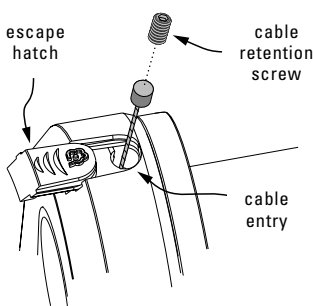

SHIFTER INSTRUCTIONS

5.0 CENTERA™

1

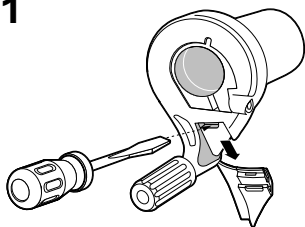

SHIFTER ANATOMY

See picture on the left page.

INSTALLATION

FRONT and REAR:

- Slide the front (rear) shifter onto the left (right) side of the handlebar.
 - If necessary, move the brake lever to allow for the shifter and the handlebar grip.
 - Bar end users – don't forget to leave room for the bar end.
- Rotate the shifter until the barrel adjuster is beneath (but out of the way of) the brake lever.
- Tighten the 3 mm hex clamp bolt to 17 in-lb. (1.9 Nm).
- Slide the plastic washer onto the handlebar.
 - The washer prevents the handlebar grip from interfering with the shifter rotation.
- Slide the handlebar grip onto the handlebar.
 - Solvents, lubricants or hair spray may damage the handlebar grips!**
 - Use only compressed air or water to aid installation.
- Feed the cable through the cable housing and stops.
- Attach the front (rear) shifter cable to the front (rear) derailleur.
- Adjust indexing per the derailleur instructions.

Attention!

- Always check the front and rear brake levers for proper operation.
- If there is interference between a shifter and a brake lever, rotate one out of the way. Check for proper brake lever operation again!

CABLE CHANGE

Hey! For the best results:

- Leave the shifter on the handlebar.
- Allow for 0.5–1" of working space around the shifter.
- Use only new, high quality cable and compressionless housing.

FRONT

- Detach the cable from the front derailleur.
- Cut the cable off 6" from the shifter barrel adjuster. Discard the old cable and cable housing.
- Use a small screwdriver to pop off the cover. (Fig. 1)
- Carefully pull the grip and the housing apart only until the cable head is exposed.
 - Be careful not to lose the spring.
- Remove and discard the rest of the old cable.
- Feed the new cable through the cable entry in the grip and then directly through the barrel adjuster.
- Line up the '1' mark with the indicator mark.

- While pulling the cable snug, snap the grip and the housing back together. (Fig. 2)
 - Make sure the cable is lying in the cable track before snapping the shifter closed.
- Snap the cover back into place.
- Check for proper assembly by rotating the grip and listening for the clicks.
- Feed the cable through the new cable housing and stops.
- Attach the cable to the front derailleur and adjust indexing per the derailleur instructions.

Hey! Now this is going to be easy:

- Leave the shifter on the handlebar.
- No need to move other components. – THE SHIFTER DOES NOT NEED TO BE OPENED.
- Use only new, high quality cable and compressionless housing.

REAR

- Detach the cable from the rear derailleur.
- Cut the cable off 6" from the shifter barrel adjuster. Discard the old cable and cable housing.
- Line up the 'CC' mark with the indicator mark.
- Use a small screwdriver to pop off the cover. Do not pull apart the shifter. (Fig. 1)
- Push the old cable into the shifter to expose the cable head. (Fig. 3)
- Remove and discard the rest of the old cable.
- Feed the new cable 0.25" straight into the cable entry. (Fig. 4)
- Bending the cable away from the cable track, continue to push the cable completely through the shifter.
 - This causes a slight bowing of the cable which aids in the installation. (Fig. 5)
- Feed the cable through the barrel adjuster and pull the cable snug.
- Check that the cable is lying in the cable track. Snap the cover back into place.
- Check for proper assembly by rotating the grip and listening for the clicks.
- Feed the cable through the new cable housing and stops.
- Attach the cable to the rear derailleur and adjust indexing per the derailleur instructions.

Hey again!

- Clean all shifter parts using ONLY water and mild soap.
- Use ONLY Grip Shift Jonnisnot Grease for any shifter lubrication.



2

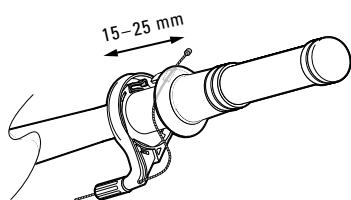

3

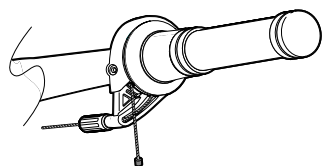

4

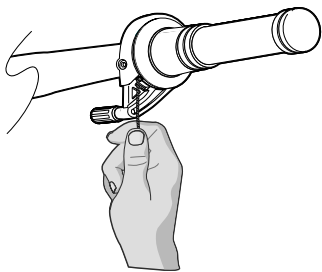

5

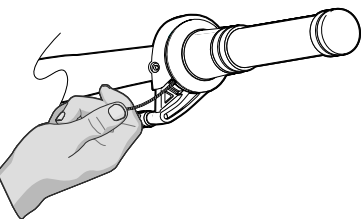

SHIFTER INSTRUCTIONS

MRX™

1

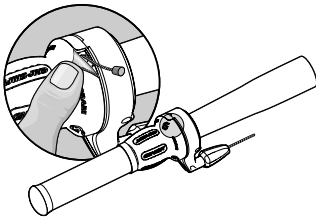

Models 201-10, -30

SHIFTER ANATOMY

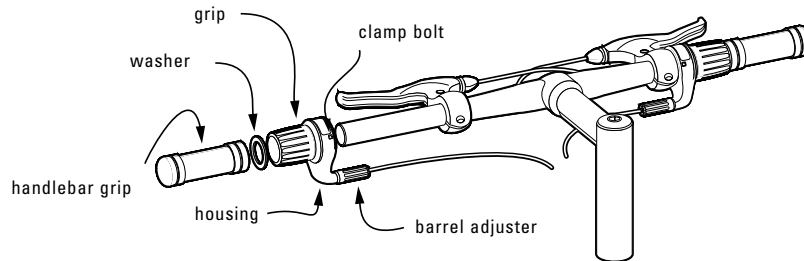

INSTALLATION

FRONT and REAR:

(For use with NON-ALUMINUM handlebars ONLY)

- Slide the front (rear) shifter onto the left (right) side of the handlebar.
 - If necessary, move the brake lever to allow for the shifter and the handlebar grip.
 - Bar end users – don't forget to leave room for the bar end.
- Rotate the shifter until the barrel adjuster is beneath (but out of the way of) the brake lever.
- Tighten the 2.5 mm hex clamp bolt to 15 in-lb. (1.7 Nm).
- Slide the plastic washer onto the handlebar.
 - The washer prevents the handlebar grip from interfering with the shifter rotation.
- Slide the handlebar grip onto the handlebar.
 - Solvents, lubricants or hair spray may damage the handlebar grips!**
 - Use **only** compressed air or water to aid installation.
- Thread the cable through the cable housings and stops.
- Attach the front (rear) shifter cable to the front (rear) derailleur.
- Adjust indexing per the derailleur instructions.

Not recommended for use on thin walled aluminium handlebars such as Hyperlite® type handlebars.

Attention!

- Always check the front and rear brake levers for proper operation.
- If there is interference between a shifter and a brake lever, rotate one out of the way. Check for proper brake lever operation again!

CABLE CHANGE

Check this out:

- Leave the shifter on the handlebar.
- No need to move other components – **THE SHIFTER DOES NOT NEED TO BE OPENED.**
- Use only new, high quality cable and compressionless cable housing.

FRONT – Models 201-10, -30 and
REAR – Models 201-60, -70

See Figure 1 (front) or 2 (rear).

- Detach the cable from the appropriate derailleur.
- Cut the cable off 6" from the shifter barrel adjuster. Discard the old cable and cable housing.
- Line up the '1' (front) or HIGHEST gear number (rear) mark with the indicator mark.
- Carefully peel back the corner of the grip cover shown in Figure 1 (front) or Figure 2 (rear).
 - Use your fingernail or a small screwdriver.
- Remove and discard the rest of the old cable.
- Feed the new cable through the cable entry in the grip and out through the barrel adjuster.
- Feed the cable through the new cable housing and stops.
- Attach the cable to the appropriate derailleur and adjust indexing per the derailleur instructions.

Hey! Make it easy on yourself:

- Leave the shifter on the handlebar.
- Allow for 0.5–1" of working space around the shifter.
- Use only new, high quality cable and compressionless housing.

2

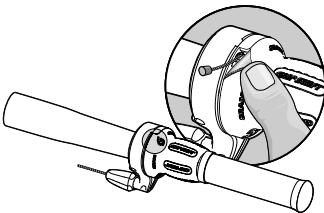

Models 201-60, -70

3

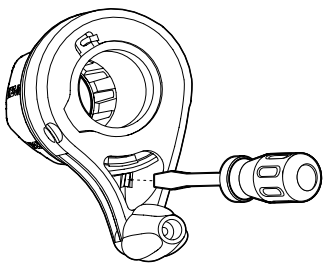

Models 201-12, -32

SHIFTER INSTRUCTIONS MRX™

4

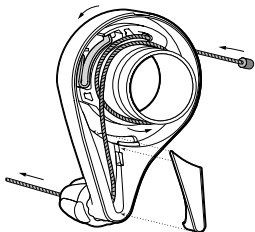

Models 201-12, -32

5

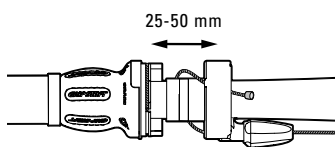

Models 201-12, -32

6

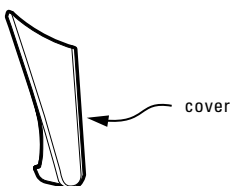

FRONT – Models 201-12, -32

1. Detach the cable from the front derailleur.
2. Cut the cable off 6" from the shifter barrel adjuster. Discard the old cable and cable housing.
3. Use a small screwdriver in the rear slot of the housing to pop off the cover.
(Fig. 3)
4. Rotate the shifter so the indicator mark is beyond the '3' mark and carefully pull the grip and the housing apart.
 - Be careful not to lose the spring.
5. Remove and discard the rest of the old cable.
6. Feed the new cable through the cable entry in the housing and loop it once around the handlebar.
7. Feed the cable out through the barrel adjuster. *(Fig. 4)*
8. Line up the '1' mark with the indicator mark.
 - This will also align the small retention tab on the housing with the grip.
9. Lay the cable over the 'shovel' on the grip.
10. While pulling the cable snug, snap the grip and the housing back together.
(Fig. 5)
 - Make sure the cable is lying in the cable track before snapping the shifter closed.
11. Snap the cover back into place.
12. Check for proper assembly by rotating the shifter and listening for the clicks.
13. Feed the cable through the new cable housing and stops.
14. Attach the cable to the appropriate derailleur and adjust indexing per the derailleur instructions.

Hey again!

- Clean all shifter parts using **ONLY** water and mild soap.
- Use **ONLY** Grip Shift Jonnisnot Grease for any shifter lubrication.

SHIFTER INSTRUCTIONS QUARZ™, NEOS™, SPECTRO™, BANDIX™, TRAXX™

1

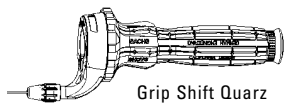

Grip Shift Quarz

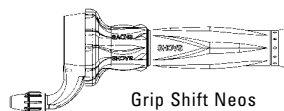

Grip Shift Neos

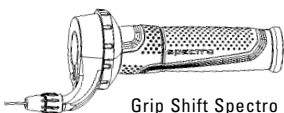

Grip Shift Spectro

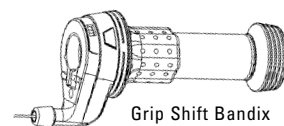

Grip Shift Bandix

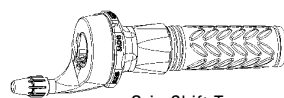

Grip Shift Traxx

TECHNICAL SPECIFICATIONS

- **Grip Shift Quarz:**
Two-part grip, 3 speeds left, 8 or 9 speeds right, gear indicator in window, Tune-to-Terrain adjustable shifting force, easy cable replacement with the Cable Quick Release feature.
- **Grip Shift Neos:**
Two-part grip, 3 speeds left, 7 or 8 speeds right, gear indication printed on shifter housing.
- **Grip Shift Spectro:**
Two-part grip, 3 speeds left, 6, 7 or 8 speeds right, gear indication printed on shifter housing.
- **Grip Shift Bandix:**
Two-part grip, 2 or 3 speeds left or right, 5, 6 or 7 speeds right, gear indication printed on shifter housing.
- **Grip Shift Traxx:**
Two-part grip, 3 speeds left, 6 or 7 speeds right, gear indication printed on shifter housing.

ASSEMBLY REQUIREMENTS / MOUNTING PROCEDURE

- Handlebar diameter "Y": 22.0–22.4 mm
- Length of straight handlebar end "X":
Quarz/Neos 160 mm, Spectro/Traxx 150 mm, Bandix 135 mm.

Note: These measurements do not take into account the brake lever clamp dimension (Fig. 2).

Assembly (Fig. 3):

Slide housing (1) with turning grip (2) onto the handlebar. Follow with two thrust washers (3).

- Mount fixed grip (4) as far as it will go.
Warning: Do not use grease for mounting the fixed grips (4)!
- Place the housing (1) with the turning grip (2) against the fixed grip in such a way as to give the thrust washers (3) some free room. Adjust housing and tighten bolt to a torque of 1.5–2.5 Nm.

Note:

In order to mount the rotational shifter onto handlebars with very narrow bending radiuses (integral handlebars), the housing (1) and turning grip (2) may be separated. In this case:

- **Fig. 4:** Hold the housing (1) with one hand and the rotational grip (2) with the other, then apply the necessary force to separate them.
- Slide the housing (1) followed by the grip (2) onto the handlebar.

- Bring lug and corresponding nut together for cover and push into element (Fig. 4).
- Continue the mounting procedure as indicated above.

REPLACING CONTROL CABLE

- **Fig. 5:** Remove cable cap (5) from shifter body with a sharp tool and turn shifter forward as far as it will go. Cable head will appear in window. Slide cable head from cable guide and pull out cable.
- Route new cable through opening, adjust onto frame as desired and pull into cable guide up to the stop.
- Connect the cable to the front or rear derailleur or hub and close opening with cable cap (5).
- When necessary, shifting adjustment can be corrected by turning the adjusting barrel (6).

ADJUSTING THE REQUIRED HAND FORCE / MAINTENANCE

Fig. 6 – (only the Grip Shift Quarz) In order to increase or decrease the required hand force, move the bar (7) in the plus (+) or minus (–) direction. This grey bar is found on the inner part of the shifter body.

All shifters are permanently lubricated at manufacturing site and are normally maintenance free.

2

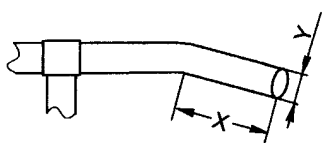

3

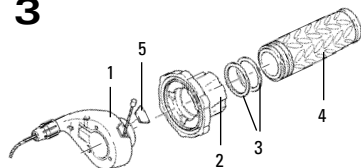

4

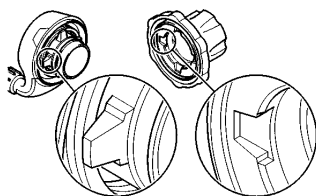

5

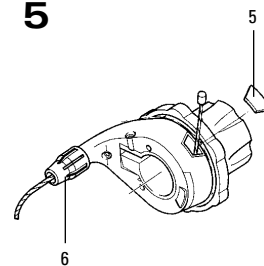

6

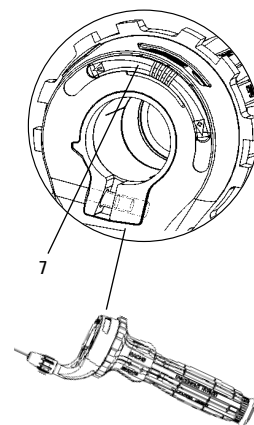

NIGHTCRAWLER™ INSTRUCTIONS

1

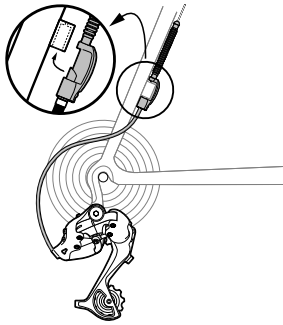

Steps 6 – 7

2

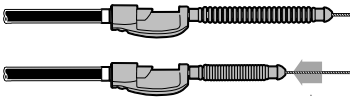

Steps 8 – 9

NIGHTCRAWLER™ ANATOMY

Steps 1 – 5

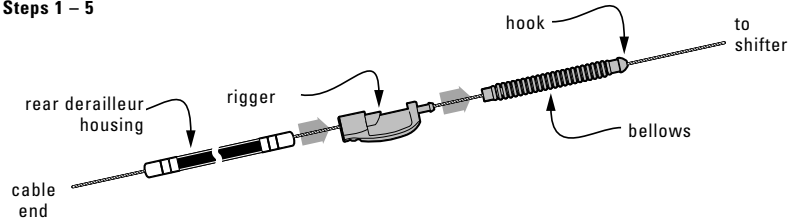

COMPATIBILITY

- Fits most frames
- Use with derailleur cables ONLY

SETUP

- No tools needed
- Cable detached from the rear derailleur
- Rigger separate from the bellows

INSTALLATION

1. Feed the cable through the bellows – hook end first.
2. Feed the cable through the rigger – bellows end first.
3. Join the rigger to the bellows.
4. Feed the cable through the rear derailleur housing.
5. Seat the rear derailleur housing into the rigger.
6. Slide the rigger into the rear derailleur cable stop.
7. Re-attach the cable to the rear derailleur.
8. Check that the chain is on the smallest cog.
9. Using your fingers, slide the hook end of the bellows towards the rigger until fully compressed.

HUBS INSTRUCTIONS

ASSEMBLY DRAWING PLASMA POWERDISC

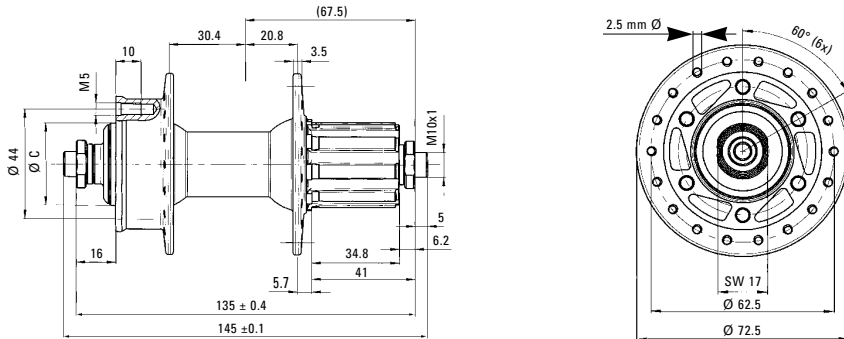

REAR HUBS MTB, TREKKING

		PLASMA/ POWERDISC	QUARZ/ POWERDISC	NEOS	CENTERA	TRAXX
Over locknut dimension	126 mm					X
	130 mm		X		X	X
	135 mm	X	X	X	X	X
Axle length (hollow axle)	134 mm					X
	139 mm		X		X	X
	145 mm	X	X	X	X	X
Number of spoke holes	32	X	X	X	X	X
	36	X	X	X	X	X
Spoke hole "O"	2.5 mm + 0.15	X	X	X	X	X
Spoke hole reference "O"		45 mm	45 mm	45 mm	45 mm	45 mm
Powerdisc hubs		62.5 mm	62.5 mm			
Distance middle flange to middle fork width						
• 8-speed / OLD 135	right (drive side)	20.8 mm	20.8 mm	20.8 mm	20.8 mm	17.9 mm
	left	30.4 mm	30.4 mm	30.4 mm	30.4 mm	33.3 mm
• 8-speed / OLD 130	right (drive side)		18.3 mm	18.3 mm	18.3 mm	
	left		32.9 mm	32.9 mm	32.9 mm	
• 7-speed / OLD 135	right (drive side)			23.8 mm	23.8 mm	
	left			27.4 mm	27.4 mm	
• 7-speed / OLD 130	right (drive side)			21.3 mm	21.3 mm	20.4 mm
	left			29.9 mm	29.9 mm	30.8 mm
Mounting	Quick release	X	X	X	X	X
	Solid axle				X	X
Axle ends Ø		10 mm	10 mm	10 mm	10 mm	10 mm
Bearings and sealing	Cartridge bearing	X	X			
	Cone/lip seal			X		
	Cone/labyrinth				X	
	Cone/dust cap					X
Cassette body	Bearings	Cone	Cone	Cone	Cone	Freewheel

HUBS INSTRUCTIONS

FRONT HUBS MTB, TREKKING

		PLASMA	QUARZ	NEOS	CENTERA	TRAXX
Over locknut dimension	100 mm	X	X	X	X	X
Axle length hollow axle	108 mm	108 mm	108 mm	108 mm	108 mm	107 mm
	solid axle	–	–	–	136 mm	136 mm
Spoke holes	32	X	X	X	X	X
	36	X	X	X	X	X
Spoke hole "O"	2.5 mm + 0.15	X	X	X	X	X
Spoke hole reference "O"		39 mm	39 mm	39 mm	39 mm	39 mm
Distance middle flange to middle fork width	right (drive side)	29.6 mm	29.6 mm	29.6 mm	29.6 mm	29.6 mm
	left	29.6 mm	29.6 mm	29.6 mm	29.6 mm	29.6 mm
Mounting	Quick release	X	X	X	X	X
	Solid axle				X	X
Axle ends Ø		9 mm	9 mm	9 mm	9 mm	9 mm
Bearings and sealing	Cartridge bearing	X	X			
	Cone/lip seal			X		
	Cone/labyrinth				X	
	Cone/dust cap					X

1

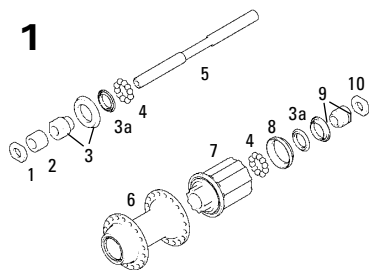

Neos

DISMANTLING / ASSEMBLING – VERSION WITH CONE BEARING

Dismantling – Fig. 1: (Neos, Centera, 5000)

- Unscrew axle nut (1) on the non-drive side and remove, using a 17 mm wrench, while holding the adjusting cone (3) in place with a 15 mm wrench.
- Unscrew adjusting cone (3) and pull out axle (5).
(Only remove dust cap (8) and cone with plastic cover (9) if damaged.) When replacing the cone (9) measure the distance to the axle end so that the new part is fitted in the same position. Tighten axle nut (1) 15–20 Nm (11–14.75 ft.lbs.) while holding the cone (9) in place with a 15 mm wrench.
- Remove 9 balls (4) from the hub shell.
- Remove body bolt in the hub shell using a 12 mm hex and remove body (7).
Note: in the case of versions with cone bearing, the body bolt remains in the hub shell – the non-drive side bearing shell would have to be disassembled before the bolt can be removed.
- Use a suitable tool to drive the worn bearing shell out of the hub shell (6). Press new bearing shell in completely.
- The body (7) cannot be dismantled and must, if necessary, be replaced completely.
- Clean all parts if necessary – replace damaged/worn parts.

Differences specific to type:

- On the Centera 8-speed version, a labyrinth cover pressed onto the cone (3+9) seals the hub on drive and non-drive side – the Centera 7-speed and 5000 version has no dust cap (8).
- On the Neos, the rubber lip seal (3a) is fitted on both sides. It is fitted completely onto the labyrinth cover; the sealing lip must point towards the labyrinth cover to function.

Assembly:

- Grease ball running surfaces on both sides and insert 9 balls on each side.
- Insert preassembled axle with cone (9) and axle nut (1).
- On the non-drive side, tighten adjusting cone (3) on the balls so that it is free from play but without exerting pressure. Fit spacer (2). Hold adjusting cone in place with a 15 mm wrench and tighten axle nut (1) to a torque of 15–20 Nm (11–14.75 ft.lbs.).
- To fit dust cap (8), see version with cartridge bearing, assembly (next page).

HUBS INSTRUCTIONS

2

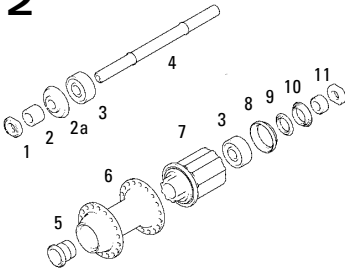

Quarz

VERSION WITH CARTRIDGE BEARING

Dismantling – Fig. 2:
(Plasma, Quarz, New Success, 7000, plus Plasma and Quarz for Powerdisc)

- Unscrew and remove axle nut (1) using a 17 mm wrench on the driver side, while holding the opposite side in place with a 17 mm wrench.
- Remove dust cap (10) and rubber lip seal (9).
- Remove axle (4) using a plastic or rubber hammer.

Important: Take care of the adjusting washers under the outer bearing ring (see body bearing assembly instruction).

- Clean all parts if necessary – replace damaged/worn parts.
- After unscrewing the nut (1), the bearing (3) on the axle (4) can be removed with the spacer and the dust cap.
- Use a 12 mm hex key to unscrew the body bolt (5) in the hub shell (6) and remove body (7).
- Use a suitable tool on the opposite side to drive ball bearing (3) out of the body – to do so, place the body on a board or in a vise. The cover (8) is driven out at the same time.

3

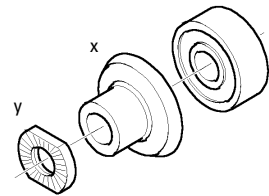

4

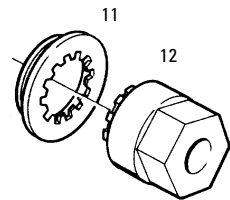

Differences specific to type:

- The cassette hubs Plasma and New Success (Fig. 2) have an aluminum spacer (2) and an aluminum cover (2a) between the left bearing (3) and the axle nut (1). The axle nuts (1) have a turned groove which points towards the dropout when installed.
- Quarz and 7000 (Fig. 3) have a longer steel spacer (x) with a pressed-on plastic labyrinth cover between the left bearing (3) and the axle nut (1). Both axle nuts (y) are grooved on both sides.

Assembly:

- Press bearing (3) as far as it will go into body (7).
- Press in dust cap (8) with the larger diameter first – the locking for the Power Glide cassette (11) and assembly tool (12) (Fig. 4) will be required – tighten locking completely and the dust cap will be in exactly the right position
- Push the bearing (3) completely onto the longer end of the axle. Fit aluminum cover and aluminum spacer (Plasma) and tighten axle nut (1) to a torque of 15–20 Nm (11–14.75 ft.lbs.).
- Before fitting the left bearing, the adjusting washers provided must be inserted into the hub shell. These washers prevent undesirable bearing play.
- Insert preassembled axle with bearing into the hub shell and press in bearing completely.

Important – the following applies to both bearings: When pressing in the bearing, only exert force via the outer bearing ring.

5

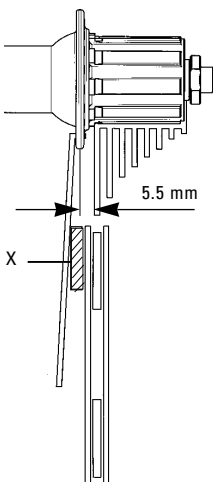

- Push rubber lip seal (9) completely onto the spacer with pressed-on labyrinth cover (10) – the sealing lip should point towards the labyrinth cover.
- Fit spacer (10) to axle.
- Tighten axle nut (1) – hold the opposite side in position with a 17 mm wrench and tighten nut to a torque of 15–20 Nm (11–14.75 ft.lbs.).

CONDITIONS FOR LACING SPOKES / POWER GLIDE ASSEMBLY / CHAINS

Conditions for lacing spokes:

- In the case of MY '99 cassette hubs, the distance from the flange center to the 1st (largest) sprocket is reduced from 7.0 mm to 5.5 mm. (compatible with Shimano®). This results in different spoking variants **When the rear derailleur (largest sprocket) is in the limit position, it is important to make sure that there is always sufficient space (X) between spokes and cage and that they do not come into contact (see Fig. 5).**

Allowed:

- Radial with spoke heads on drive side.
- Crossed at least 2x.y.

Not allowed:

- Radial spoking with spoke heads inside or crossed 1x on drive side.

Note:

With Traxx rear derailleur, special attention must be paid to the low gear limit screw since, due to the width of the rear derailleur, there is little space between rear derailleur and spokes.

Assembling Power Glide cassettes

- Push preassembled cassette section (2) onto the driver (1) (teeth only allow in one position).
- Type "A" 14 - 32 Z with 7 sprockets is assembled with a spacer (3) under the 14 T sprocket (4) (Fig. 6).
- Type "D" 12 - 28 Z with 7 sprockets does not require spacer (3, Fig. 6).
- Type "B" 11 - 28 Z with 8 sprockets, sprocket 12 Z (7) and sprocket 11 Z (8) are not pre-assembled (Fig. 7).
- Type "C" 12 - 32 Z 8-sprocket, only sprocket 12 Z (7, Fig. 7) is not pre-assembled, 7 sprockets with 6 spacers are pre-assembled.
- All sprockets are fitted with the flange first and the corresponding tooth profile, the lock ring (5) is screwed in using the assembly tool (6) and tightened to a torque of 40 Nm (30 ft.lbs.).

Important:

- **Do not use tool without its spacer or the hub seal could be damaged.**
- **Do not fit MY '97 8-speed cassette to MY '98 cassette hubs since the thread of the locking will not grip sufficiently.**

HUBS INSTRUCTIONS

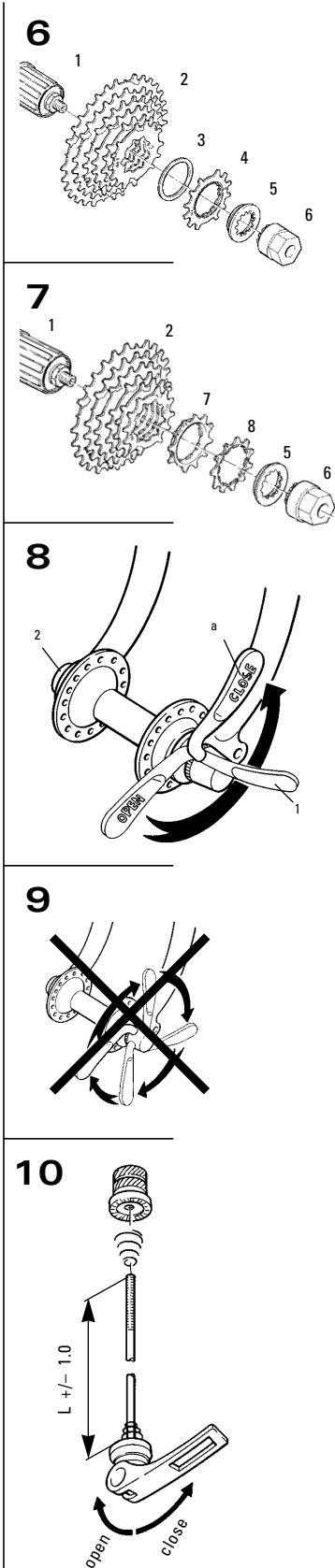

Chains:

- Only retrofit the following chain:
Power Chain, all chain models except PC 1 and PC10.

Important – the use of other chains will impair shifting functions considerably.

Compatibility

Power Glide cassettes are Shimano® compatible if used with Power Chain chains. Power Glide cassettes can be replaced by Shimano® cassettes.

FITTING THE WHEEL

- Insert wheel into dropouts of frame or front fork and align. Only use correct length quick-release skewers (see table below).
- Turn clamping lever 1 to the outside until it is at least at right angles to the cycle open (**Fig. 8**).
- Tighten adjusting nut 2 as much as possible by hand.
- Turn clamping lever 1 to closed position “a” (the word “close” is visible from the outside). When closed, clamping lever should be parallel to the fork or frame. If the clamping lever closes relatively easily, the clamping force is insufficient. In this case, open clamping lever again, tighten adjusting nut 2 slightly more and close clamping lever again.
If considerable force is required to close the clamping lever, open the lever again,

slacken off the adjusting nut slightly and close lever again.

Important:

Do not fix wheel in place by turning the quick-release lever (Fig. 9).

It is essential that the operating instructions for quick-release device No. 4668 001 001 be passed on to the end user.

MAINTENANCE / CARE

- When cleaning your bike, do not expose hub to compressed water (i.e. high pressure hose, etc). If water gets into system, malfunction may occur.
- The hubs have been factory lubricated and are nearly maintenance-free.

QUICK RELEASE (FIG. 10)

	Ref. Number		Overlocknut dimension	L	Dropout	Usable for suspension
Plasma / Quarz	88 4689 518 001	front	100	131 mm	7.0–10.0 mm	X
	88 4689 518 002	front	100	125 mm	4.0–7.0 mm	X
	88 4689 519 002	rear	135	160 mm	4.0–7.0 mm	
	dto.	rear	130	dto.	7.0–10.0 mm	
	88 4689 520 002	rear	130	155 mm	4.0–7.0 mm	
Neos/Centera	88 4689 519 001	rear	135	166 mm	7.0–10.0 mm	
	88 4689 521 001	front	100	131 mm	7.0–10.0 mm	X
	88 4689 521 002	front	100	125 mm	4.0–7.0 mm	X
	88 4689 522 002	rear	135	160 mm	4.0–7.0 mm	
	dto.	rear	130	dto.	7.0–10.0 mm	
Traxx	88 4689 523 002	rear	130	155mm	4.0–7.0 mm	
	88 4689 522 001	rear	135	166 mm	7.0–10.0 mm	
	88 4689 513 001	front	100	128 mm	5.0–8.0 mm	X
	88 4689 513 002	front	100	124 mm	3.5–6.5 mm	X
	88 4689 514 001	rear	135	160 mm	4.0–7.0 mm	
	dto.	rear	130	dto.	7.0–10.0 mm	
	88 4689 515 001	rear	135	165 mm	7.0–10.0 mm	
	88 4689 516 001	rear	130	154 mm	4.0–7.0 mm	
	88 4689 517 001	rear	126	151 mm	4.0-7.0 mm	

CASSETTES INSTRUCTIONS POWER GLIDE

1

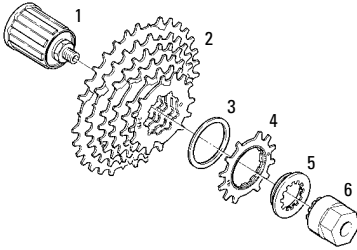

TECHNICAL SPECIFICATIONS

Power Glide cassette types

Type	Connecting rings	
	Number	Color
• Type "A" / 14–32 teeth, 7-speed (14 - 16 - 18 - 21 - 24 - 28 - 32)	5	black
• Type "B" / 11–28 teeth, 8-speed (11 - 12 - 14 - 16 - 18 - 21 - 24 - 28)	5	grey
• Type "C" / 12–32 teeth, 8-speed (12 - 14 - 16 - 18 - 21 - 24 - 28 - 32)	6	grey
• Type "D" / 12–28 teeth, 7-speed (12 - 14 - 16 - 18 - 21 - 24 - 28)	5	black

2

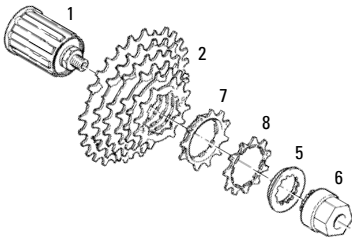

The sprocket cassettes are supplied pre-assembled with connecting rings. (Figs. 1 and 2)

Warning: Black connecting rings for 7-speed cassettes, grey connecting rings for 8-speed cassettes. Do not fit grey connecting rings with sprockets which have ≥ 16 teeth and a circular marking on the inner diameter. Sprockets with ≥ 16 teeth and production date 09/97 or later are marked with a triangle on the inner diameter above the wide tooth. Sprockets produced before this date are marked with a circle. (Other sprockets are still marked with a circle.) Do not mix sprockets with different markings. (See also Fig. 3)

Power Chain chains:

- All types apart from PC 1 and PC 10. Warning: The use of other chains will impair shifting considerably.

Compatibility:

- Power Glide cassettes are Shimano® compatible if used with Power Chain chains.
- Power Glide cassettes can be replaced by Shimano® cassettes.

FITTING THE POWER GLIDE CASSETTES

- Fit pre-assembled cassette (2, Fig. 1) onto the splines of the cassette body (1) – toothing only allows it to be fitted in one position. Further assembly:
 - Type "A" / 14–32 T, 7-speed: fit intermediate ring (3, Type A only) and 14 tooth sprocket (4) collar first in accordance with tooth profile.
 - Type "B" / 11–28 T, 8-speed: fit 12 + 11 tooth sprockets (7 + 8, Fig. 2) collar first.
 - Type "C" / 12–32 T, 8-speed: fit 12 tooth sprocket collar first.
 - Type "D" / 12–28 T, 7-speed: fit 12 tooth sprocket collar first (ring 3 not needed).
- Turn screw (5) with assembly tool (6) and tighten to a torque of 40 Nm.

Warning:

Do not use tool without spacer as this could damage the hub seal. (Art. No. 4624 411 010)

Replacing individual sprockets:

The individual sprockets are connected by a clip system and can be fitted without tools. The connecting rings are plastic and have three lugs on each side which lock into the corresponding recesses in the sprockets. Certain markings (Fig. 3) on the sprockets and connecting rings help to make assembly easier:

- The sprockets are embossed with:
 - a marking indicating use, e.g. 28 A–D (28 teeth, suitable for all cassette types A, B, C and D)
 - a triangular marking (≥ 16 teeth) above the wide tooth on the inner diameter.
- The connecting rings have a circular marking above the wide tooth on the inner diameter.

To assemble, align the markings and press the sprockets and the connecting rings together gently so that they interlock.

Warning:

Always use the same number of teeth and sprocket type; any change in stepping will cause shifting problems.

3

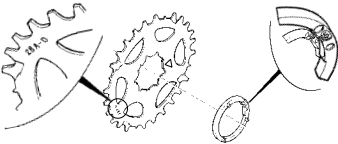

CRANK SET INSTRUCTIONS

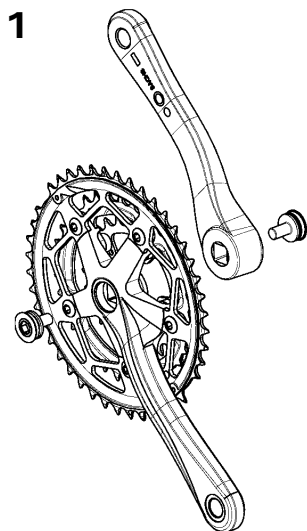

TECHNICAL SPECIFICATIONS AND ASSEMBLY REQUIREMENTS

		Quarz	Neos	Centera
Power Glide Chainrings		X	X	X
Number of teeth	Top	44 T	44 T	44 T
	Middle	34 T	34 T	34 T
	Small	24 T	24 T	24 T
Crank length	170 mm	X	X	X
	175 mm	X	X	X
Low profile		X	X	X
Chain guard Option		X	X	X
Chain type		PC/IG *	PC/IG *	PC/IG *
For derailleur "compact drive"		X	X	X
Taper of bottom bracket cassette		JIS	JIS	JIS
square nut/screw included in the program				
Chain line C. L.	47.5 +2.5	X	X	X
Axle length of bottom bracket cassette	110 mm	X	X	X
Q-Factor		161 mm	161 mm	161 mm

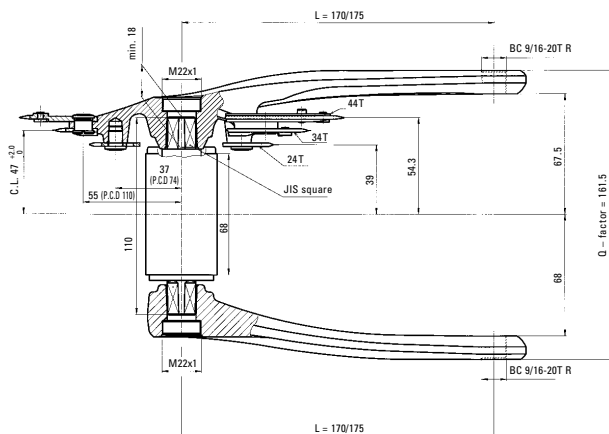
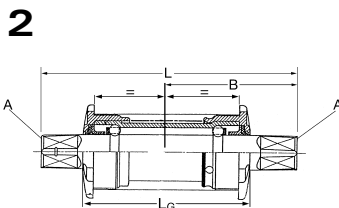

Quarz
Neos
Centera

Assembly Requirements – Fig. 2

Combination crank set/Bottom bracket cassette (not a SRAM part)

Crank set	Chain line	C. L.	Bottom bracket axle				L _G max
			L	B	Taper A		
					ISO	JIS	
Quarz triple	47.5 +2.5	110	55		X	77	
Neos triple	47.5 +2.5	110	55		X	77	
3000 triple	47.5 +2.5	110	55		X	77	

ASSEMBLY

Task	Procedure	Data, tools
Mounting crank	<ul style="list-style-type: none"> Slide crank onto taper of bottom bracket axle Do not oil taper or use any fatty solutions! Tighten bolt of the crank/Bottom bracket connection 	Allen key 8 mm Torque 40 Nm

CHAINS INSTRUCTIONS

TECHNICAL SPECIFICATIONS AND APPLICATION

1

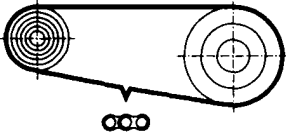

2

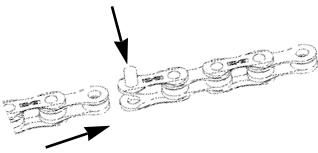

3

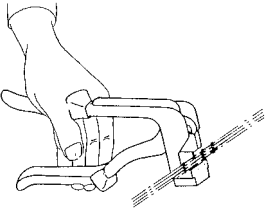

4

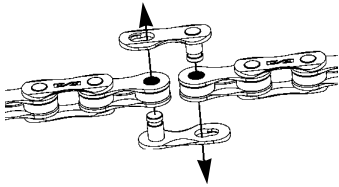

5

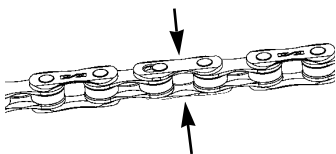

6

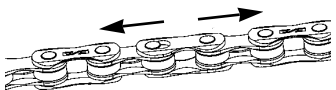

Type	PC 1	PC 41	PC 51	PC 80R	PC 61	PC 91	PC 59	PC 89R
Use	Single / multi-speed hubs	MTB	MTB/ROAD	ROAD	MTB	MTB	ROAD / MTB	ROAD
Dimensions	1/2" x 1/8"			1/2" x 3/32"				
For derailleur	-	X	X	X	X	X	X	X
HG* compatible	-	X	X	X	X	X	X	X
IG* compatible	-	X	X	X	X	X	-	-
Exa-Drive* compatible	-	X	X	X	X	X	X	X
Max. no. of sprockets	1	8	8	8	8	8	9	9

* HG/IG are registered trademarks of Shimano Inc. Japan / EXA-Drive is a registered trademark of Campagnolo S.R.L. Italy

FEATURES

- Chamfered outer and inner plates
- Narrow width
- Pins chromized and heat-tret
- Power Link
- High load capacity
- Stamped outer plate (on PC 80R and PC 91)
- **NEW: 9-speed chains, PC 59 und PC 89R**

BENEFITS

- Easy and precise shifting
- Compatible with all indexed shifting systems
- Minimum chain wear
- High load capacity
- Reduced weight

ASSEMBLY (DERAILLEUR/CHAINS 1/2" X 3/32")

Chain length:

(An assembly tool will be required to shorten the chain, see also point "Closing chain", e.g. SRAM assembly pliers.)

- Replacing a worn chain: measure the worn chain and shorten the new chain to the same length (number of links).
- Initial assembly:
 - Shorten chain to the length specified by the derailleur manufacturer.
 - SRAM derailleurs: place chain over largest front chainwheel and largest rear sprocket and add 2 links or 1 link + Power Link (Fig. 1). For frame versions with suspension, please read bicycle producer's instruction.

Closing chain:

(standard version with clamping pin)

- Fit chain, bring the two ends together and press pin through with assembly tool. The pin must extend by the same amount at both outer plates. (Fig. 2)
 - It must be possible to move the connecting link slightly.
 - The use of SRAM assembly pliers is recommended: version for chains PC 41, PC 51, PC 80R, PC 61, PC 91, Art. No. 2799 980 001. (Fig. 3)

Closing chain:

(Power Link and Power Link II connecting links)

...every chain is only as strong as its weakest link – traditionally this is the connecting link. In contrast, the POWER LINK connection is just as strong and durable as every other link in the chain. And it can be opened and closed as many times as you want without using tools.

- Fit chain, bring the two ends together and insert both halves of the Power Link into the chain ends. (Fig. 4)
- Press both halves of the connecting link together (Fig. 5) and lock in place by pulling the chain apart. (Fig. 6)
- To disassemble: Press both plates of the connecting link together (Fig. 5) while sliding the chain ends together (unlock). Remove the two halves of the link from the chain ends.

Important:

- "Power Link" (black) only for chains PC 41, PC 51, PC 80R, PC 61, PC 91.
- "Power Link II" (grey, "PL II" marked on the plate) only for chains PC 59, PC 89R.

CHAINS INSTRUCTIONS

7

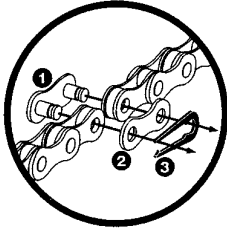

ASSEMBLY (SINGLE- AND MULTI-SPEED HUBS, CHAIN PC1, 1/2" X 1/8")

Chain length:

- Measure the worn chain and shorten the new chain to the same length (number of links).
- For frame versions with suspension please read bicycle producer's instruction.

Closing chain:

- Fit the shortened chain, bring the two ends together and connect with the chain lock. The chain lock consists of an outer plate with pins (1), an outer plate (2) and a retaining spring (3). (Fig. 7)
- Insert outer plate with pins (1) into the chain ends, attach outer plate (2) and press chain lock together (1+2). (Fig. 7)
- Attach retaining spring (3) with the closed end of the retaining ring pointing in the direction of chain travel. (Fig. 8)
- Slide retaining spring in the direction of arrow X (Fig. 8) to engage it in the grooves in the pins.

8

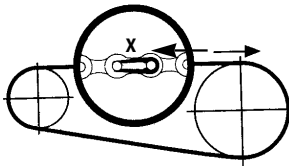

MAINTENANCE / CARE

- Regular lubrication will extend the chain's service life.
- Apply oil to the chain rollers and allow to work in.
- Clean dirty chains before oiling.
- Do not use any grease-dissolving or acidic agents. Cleaning agent must be rinsed off after a few minutes with water. Apply oil after chain is completely dried.

Warning:

- **Make sure the retaining spring on the chain lock resp. Power Link is locked exactly into place.**
- **Always use a new chain lock resp. Power Link when fitting a new chain. Failure to shorten the chain properly or to lock it exactly into place may cause damage to the chain and eventually total chain failure, material damage or the rider to fall off his bicycle resulting in injury.**
- **Worn sprockets should also be replaced when a new chain is fitted.**

LINEAR-PULL BRAKE INSTRUCTIONS 5.0, 7.0, 9.0

LINEAR-PULL BRAKE ANATOMY

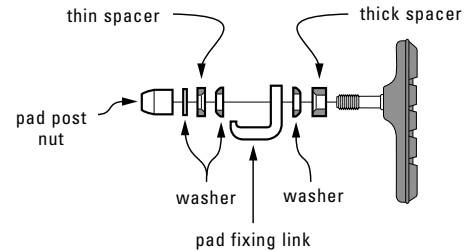
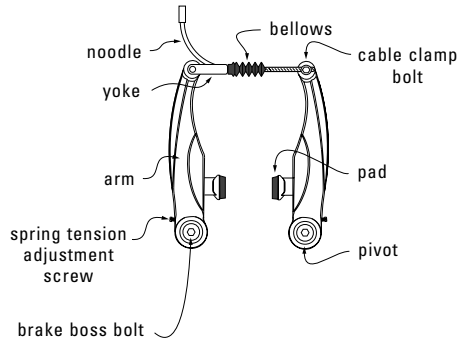
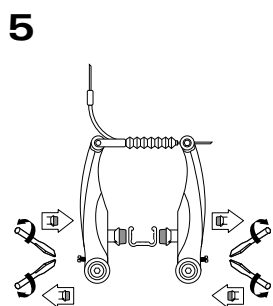
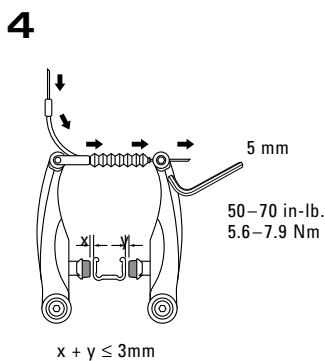
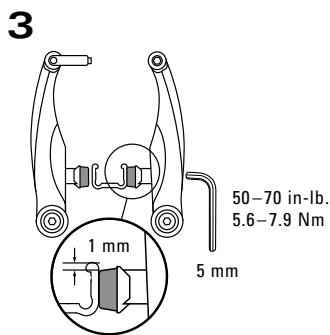
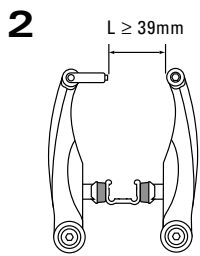
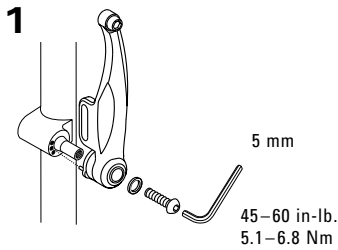

Because we care

- **Before riding, always check the front and rear brake levers for proper operation.**
- **Be sure to practice riding and braking techniques under safe conditions before heading off road or out into traffic. Sudden operation of the brakes may cause the bicycle to pitch forward, possibly causing serious injury to the rider.**

INSTALLATION

5.0 Linear-Pull Brakes only:

- Do not remove the plastic 'plug' in the pivot.
- The plug will pop free when the arm is installed onto the brake boss.
- You may discard the plug! (properly, of course.)

Fig. 1:

1. Slide the right linear-pull brake arm onto the right brake boss.
2. Align the stopper pin with the centerspring hole.
3. Using a 5mm hex wrench, tighten the brake boss bolt to 45-60 in-lb. (5.1-6.8 Nm).
4. Repeat 1-3 for the left arm. (Fig. 2)
5. Arrange the thick and thin spacers - for each pad - so when the pads are pushed against the rim, L is at least 39 mm. (Fig. 3)
6. Hold one pad against the rim using the arm.
7. Using a 5mm hex wrench, tighten the pad post nut to 50-70 in-lb. (5.6-7.9 Nm).
8. Repeat 6-7 for the other pad.

Be sure to leave about 1 mm between the top of the brake pad and the top of the rim! (Fig. 4)

Use only NEW brake cable and cable housing!

9. Run the new brake cable through the noodle and the bellows.
10. Using a 5 mm hex wrench, tighten the cable clamp bolt to 50-70 in-lb. (5.6-7.9 Nm).

Leave a total clearance of 3mm (maximum) between the brake pads and the rim! (Fig. 5)

11. Using a small screw driver, turn the spring tension adjustment screws to balance the arms and equalize the pad offsets.
 - turn the spring tension adjustment screw clockwise to pull the pad away from the rim.
 - turn the spring tension adjustment screw counterclockwise to push the pad closer to the rim.
12. Pull each brake lever - hard - at least 5-10 times.

Check that all the brake system components are functioning properly!

BRAKE LEVER INSTRUCTIONS 7.0, 9.0

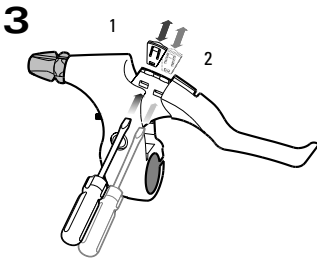
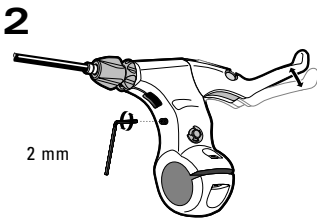
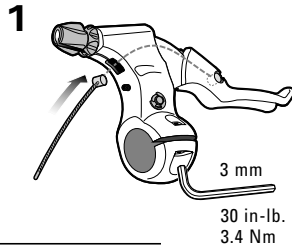

4

Warning!
SRAM integrated brake shifters are designed for use with linear-pull brakes. Do not use SRAM integrated brake shifters with conventional cantilever brakes (those with arms measuring less than 76 mm and utilizing a non-linear straddle cable). Use of SRAM integrated brake shifters with conventional cantilever brakesets will result in faulty braking performance.

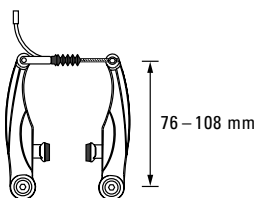

Designed for use with linear-pull brakes

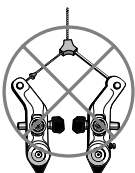

Do not use conventional cantilever brakes

BRAKE LEVER ANATOMY

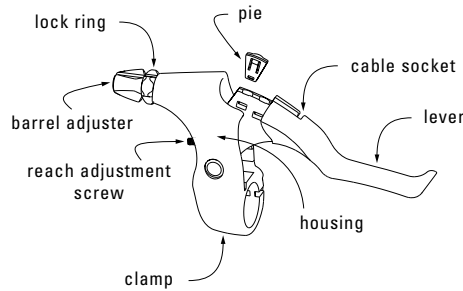

INSTALLATION

Fig. 1:

- When sliding the brake lever onto the handlebar, allow enough room for the shifter, the handlebar grip, and the bar end.
- Using a 3 mm hex wrench, tighten the clamp bolt to 30 in.-lb. (3.4 Nm).
Be careful not to over tighten!
- Line up the barrel adjuster, the lock ring, and the brake lever housing cable slots.
- Pull on the lever and push the brake cable head through the opening in the brake lever housing
Use only NEW brake cable and cable housing!
- Install the brake cable head into the cable socket in the lever.
- Set up the brakes and brake pads per brake instructions.
- Actuate each brake lever 5–10 times.

Check that all the brake system components are functioning properly!

Because we care

- **Before riding, ALWAYS check the front and rear brake levers for proper operation. If there is interference between a shifter and a brake lever, rotate one out of the way. Check for proper brake lever operation again!**
- **Be sure to practice riding and braking techniques under safe conditions before heading off road or out into traffic. Sudden operation of the brakes may cause the bicycle to pitch forward, possibly causing serious injury to the rider. Riders who are not fully confident of their bike handling skills, should NOT remove the pie from the brake lever!**

REACH ADJUSTMENT

Fig. 2:

- Using a 2 mm hex wrench...
- Turn the reach adjustment screw clockwise to bring the lever closer to the handlebars.
 - Turn the screw counterclockwise to move the lever further away.

Do NOT turn the screw past flush with the housing!

LEVERAGE ADJUSTMENT

7.0 Brake Levers ONLY:

- **STANDARD LEVERAGE OPTION** – The brake lever is packaged with the pie installed. This option is the standard configuration for most braking conditions.
- **MID LEVERAGE OPTION** – Removing the pie results in the highest brake system leverage. This option has the greatest stopping power for a given amount of effort.

Fig. 3:

9.0 Brake Levers ONLY...

- **STANDARD LEVERAGE OPTION** – The brake lever is packaged with the pie installed in position 1. This option is the standard configuration for most braking conditions.
- **MID LEVERAGE OPTION** – Moving the pie to position 2 gives you greater brake system leverage. This option increases your stopping power for a given amount of effort.
- **HIGH LEVERAGE OPTION** – Removing the pie results in the highest brake system leverage. This option has the greatest stopping power for a given amount of effort.

Removing the pie:

1. Remove the brake cable.
2. Insert a small screw driver into the adjuster window.
3. Depress the tab and push the pie out.

Installing the pie:

1. Remove the brake cable.
2. Determine which option fits your riding needs.
3. Align the runner on the pie with the curved track in the lever.
4. Press the pie into the slot until it clicks.

After any adjustment to the reach or the leverage, always check the brake cable tension to ensure proper brake system performance readjust the cable tension if necessary.

INTEGRATED BRAKE SHIFTER INSTRUCTIONS MRX™

1

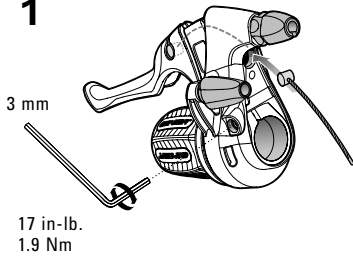

2

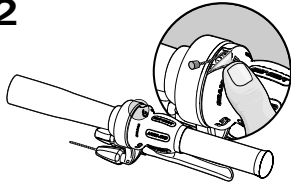

3

Warning!
SRAM integrated brake shifters are designed for use with linear-pull brakes. Do not use SRAM integrated brake shifters with conventional cantilever brakes (those with arms measuring less than 76 mm and utilizing a non-linear straddle cable). Use of SRAM integrated brake shifters with conventional cantilever brakesets will result in faulty braking performance.

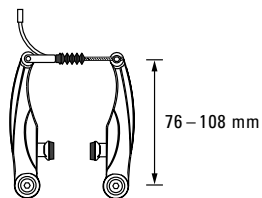

Designed for use with linear-pull brakes

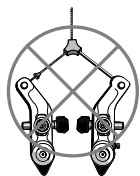

Do not use conventional cantilever brakes

4

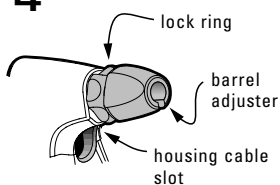

INTEGRATED BRAKE SHIFTER ANATOMY

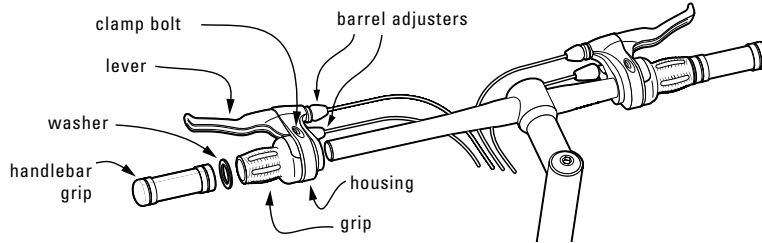

INSTALLATION

FRONT and REAR:

- Slide the front (rear) integrated brake shifter onto the left (right) side of the handlebar. Leave room for the handlebar grip.
 - Bar end users – don't forget to leave room for the bar end.
- Tighten the 3 mm hex clamp bolt to 17 in-lb. (1.9 Nm). (Fig. 1)
- Slide the plastic washer onto the handlebar.
 - The washer prevents the handlebar grip from interfering with the shifter rotation.
- Slide the handlebar grip onto the handlebar.
 - Solvents, lubricants or hair spray may damage the handlebar grips!**
 - Use only compressed air or water to aid installation.

SHIFTER:

- Feed the shifter cable through the shifter cable housing and stops.
- Attach the front (rear) shifter cable to the front (rear) derailleur.
- Adjust indexing per the derailleur instructions.

BRAKE LEVER:

- Line up the brake lever barrel adjuster, lock ring, and housing cable slots.
- Pull on the lever and push the brake cable head through the opening in the brake lever housing. (Fig. 1)
 - Use only new brake cable and cable housing.
- Install the cable head into the cable socket in the lever.
- Set up the brakes and brake pads per brake instructions.
- Actuate each brake lever 5–10 times.
 - Check that all brake system components are functioning properly!**

Because we care

- Before riding, always check the front and rear brake levers for proper operation.**
- Be sure to practice riding and braking techniques under safe conditions before heading off road or out into traffic. Sudden operation of the brakes may cause the bicycle to pitch forward, possibly causing serious injury to the rider.**

SHIFTER CABLE CHANGE

Check this out:

- Leave the shifter on the handlebar**
- No need to move other components**
- THE SHIFTER DOES NOT NEED TO BE OPENED**
- Use only new cable and compressionless cable housing**

FRONT and REAR:

- Detach the shifter cable from the appropriate derailleur.
- Cut the cable off 6" from the shifter barrel adjuster. Discard the old cable and cable housing.
- Line up the '1' (front) or HIGHEST gear number (rear) mark with the indicator mark.
- Carefully peel back the corner of the grip cover that is shown. (Fig. 2)
 - Use your fingernail or a small screw driver.
- Remove and discard the rest of the old cable.
- Feed the new shifter cable through the cable entry in the grip and out through the shifter barrel adjuster.
- Feed the cable through the new shifter cable housing and stops.
- Attach the cable to the appropriate derailleur and adjust indexing per the derailleur instructions.

Hey!

- Clean all shifter parts using ONLY water and mild soap.**
- Use ONLY Grip Shift Jonnisnot Grease for any shifter lubrication.**

APPENDIX

APPENDIX

SPARE PARTS

You can find an extensive spare parts program in SRAM's Spare Parts List Ref. Number 0368 201 060.

GLOSSARY

B-KNUCKLE

One of the two major rear derailleur body parts that anchors one side of the parallelogram links; houses the limit screws, b-adjust screw, and frame hanger bolt.

CABLE TRACK

A fixed or replaceable guide (depends on shifter) on a shifter housing that feeds the shifter cable smoothly into the shifter barrel adjuster.

COMPRESSIONLESS

CABLE HOUSING

Index shifting specific cable housing; stiff, yet bends uniformly; characterized by many small wires arranged length wise; available in lined 3.6 mm, 4 mm, 5 mm outer diameters.

DI.R.T.™

SRAM mountain bike shifting technology; front and rear derailleurs designed to operate with Grip Shift twist shifters and traditional actuation ratio shifters.

ESP®

SRAM mountain bike shifting technology; rear derailleurs designed only to operate with ESP compatible Grip Shift shifters.

FRONT INDEX SHIFTER

SRAM front indexed shifters have 3 detents that are specific to traditional actuation ratios and chainring spacing. These shifter models should only be used with the following combination of front drive train components – SRAM or Shimano® front derailleur, Shimano® bottom bracket, SRAM or Shimano® crankset.

The use of other front drive train components could cause poor shifting performance.

FRONT FRICTION SHIFTER

SRAM front friction shifters have 9 closely spaced detents that allow for greater trimming of front derailleurs. This detent design accommodates a wide variety of front drive train components.

FFS

(FASTEST FRONT SHIFTING)

SRAM patented shifting technology; accomplishes 2 chainwheel shifts with one 70° twist; Shimano® compatible.

GRIP SHIFT®

SRAM mountain bike shifting technology; twist shifters designed to operate ESP, DI.R.T. and Shimano® derailleurs.

LEVERAGE ADJUST

Three position power adjustment found on SRAM brake levers; allows for three distinct brake system power levels and customizing braking feel.

P-KNUCKLE

One of the two major rear derailleur body parts that anchors one side of the parallelogram links; mounting for the pulley cage assembly.

REACH ADJUST

Screw adjustment found on SRAM brake levers; allows changing the brake lever reach to fit different rider's hand size.

SHOVEL CAM

SRAM patented cable pulling technology; currently in MRX and MRX 170 shifters; characterized by lower shifting effort and longer rotation; Shimano® compatible.

SRT

Size, Rotation, Transition. The design goals that drove the re-invention of the original, straight bar, Grip Shift twist shifters.



SRAM

DEALER HELPDESK NUMBERS:

North America

(8 0 0) - 3 4 6 - 2 9 2 8

Europe

+ 8 0 0 / 7 7 2 6 4 3 5 7

**CORPORATE
HEADQUARTERS**

SRAM Corporation
361 West Chestnut Street
Chicago, IL 60610
Ph: 312-664-8800
Fax: 312-664-8826

**THE
NETHERLANDS**

SRAM Europe Sales &
Services B.V.
Basicweg 12-05
3821 BR Amersfoort
The Netherlands
Ph: 31-33-4506060
Fax: 31-33-4570100
email:
srameurope@sram.com

TAIWAN

SRAM Corporation
No. 1598-9 Chung Shan
Road Shen Kang Hsiang
Taichung County Taiwan,
R.O.C.
Ph: 886-4-561-3678
Fax: 886-4-561-3686

PART # 0368 201 061

Teflon® is a registered trademark of E.I. DuPont de Nemours and Co. • V-Brake™ is a trademark of Shimano®, Inc. •
Finish Line® is a registered trademark of Finish Line Technologies, Inc.

www.sram.com