	MPB S.r.l. Via Giacomo Peroni 400/402 00131 Rome - Italy	Tel +39 0641200744 Fax +39 0641200653 info@gruppompb.com
		www.gruppompb.com

User's manual

SEMS

Shielding effectiveness measurement
system

SAFETY NOTE

Read before using the product

MPB works to provide to its customers the best safety conditions available complying with the current safety standards.

The instrumentation described in this manual has been produced, tested and left the factory in conditions that fully comply the European standards.

To maintain it in safe conditions and ensure the correct use, these general instructions must be fully understood and applied before using the product.

This product is designed for industrial environment and laboratories and should be used by skilled staff only.

MPB disclaims responsibility for a different use of the device.

Conformity Certificate

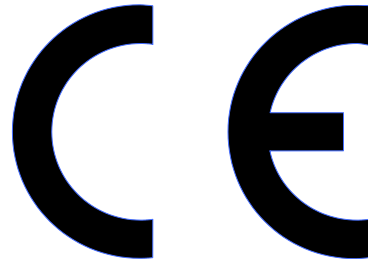

(in accordance with the Directives: EMC 89/336/EEC and Low Voltage 73/23/EEC)

This is to certify that the product: SEMS
(Measurement system of shielding effectiveness)

complies with the following European Standards:

Safety: CEI EN 61010-1 (2001)

EMC: EN 61326-1 (2007)

This product complies with the requirements of the Low Voltage Directive
2006/95/CE, and with the EMC Directive 2004/108/CE.

MPB S.r.l.

Index

1. General information	Pag.
1.1. Introduction	5
1.2. System description	5
1.3. Standard accessories	6
1.4. Optional accessories	6
1.5. Receiver front panel	7
1.6. Transmitter front panel	7
1.7. Receiver/transmitter rear panel	8
1.8. Technical specifications	9
2. Operating principle	
2.1. SEMS receiver	10
2.2. SEMS transmitter	10
2.3. SEMS system	11
3. System use and operation	
3.1. Turn on menu	12
3.2. Std Menu	12
3.2.1. Cal Menu	13
3.2.2. Show Menu	15
3.2.3. Meas Menu	17
3.3. WIZ Menu	19
3.3.1. Measurements using wizard	20
3.4. SPT Menu	24
3.5. Measuring the shielding attenuation	25
3.6. Calibration using CalKit	26
3.7. How to use the active bridge	28
3.8. Measurement with Rod antennas mod. R1	29
4. <u>SEMS PC Utility</u> software, controls and functions	
4.1. Installation	30
4.2. Options Menu	31
4.3. Archive Mode	31
4.4. List Mode	33
4.5. Receiver firmware upgrading	34

1. General information

1.1. Introduction

SEMS is thought to comply the raising need to test and verify the shielding effectiveness of shielded environment in hospitals and industries.

This system allows to measure automatically with high speed and accuracy the attenuation value of the magnetic and electric field in shielded environments.

1.2. System description

The shielding effectiveness measurement system has a transmitter and a receiver, both of them are provided with a pair of very small antennas, one is used to measure the magnetic field attenuation in the 2MHz to 128MHz frequency range, the other one is used to measure the electric field attenuation in the 60 to 300MHz frequency range.

Contrary to today's available systems, that measure the shielding effectiveness on few frequency points, SEMS allows to perform a complete test on the whole frequency ranges continuously. Another improvement compared to the standard system is the synchronization component, TX and RX are connected by a wireless system that allows to perform automatically the measurement minimizing the user's errors.

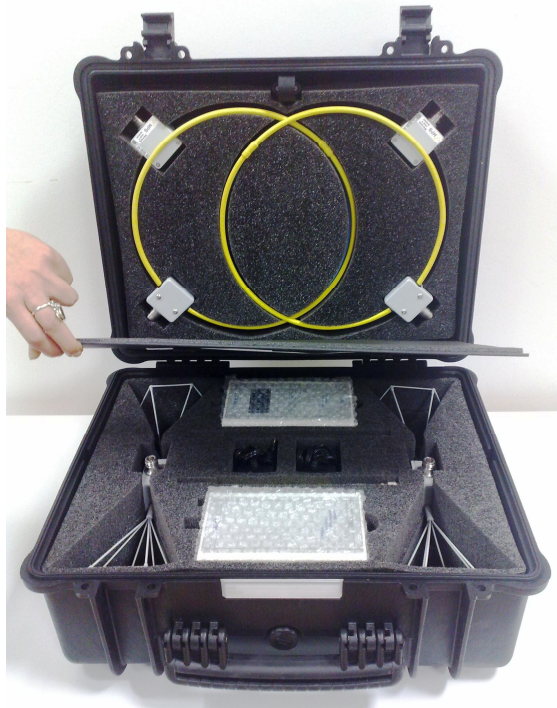

Picture n°01

SEMS in the transport bag

1.3. Standard accessories

- 1) SEMS receiver
- 2) SEMS transmitter
- 3) 2 biconical antennas (60...300 MHz)
- 4) 2 loop antennas (2...128 MHz)
- 5) 2 RS232/wireless
- 6) 2 Battery chargers
- 7) 2.4GHz Active bridge
- 8) 2 adapters for the antennas
- 9) RS232 cable and RS232-USB adapter
- 10) User's Manual and software SEMS PC utility in a USB key
- 11) Carrying bag

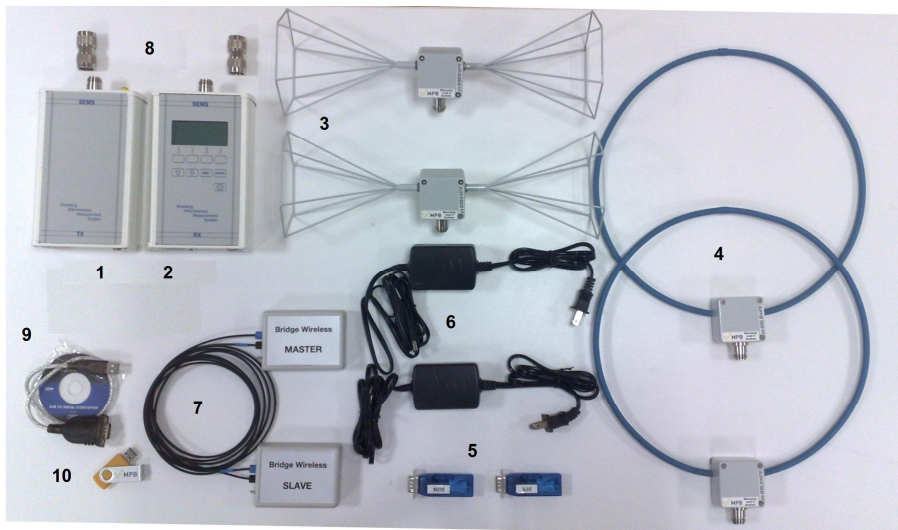

Picture n°02

1.4. Optional accessories

- 2 Loop antennas Mod. L2, 10 kHz...4 MHz frequency range
- 2 Rod antennas Mod. R1, 1MHz...60 MHz frequency range, plus 10 dB attenuator (read chapter 3.7)
- 2 Wooden tripod Mod. TR-02-A

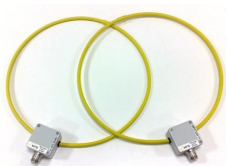

Loop Mod.L2



Rod Mod.R1



Tripod Mod.TR-02-A

1.5. Receiver front panel

In the Picture below(n°03) is represented SEMS receiver front panel. It has a display and a command keyboard.

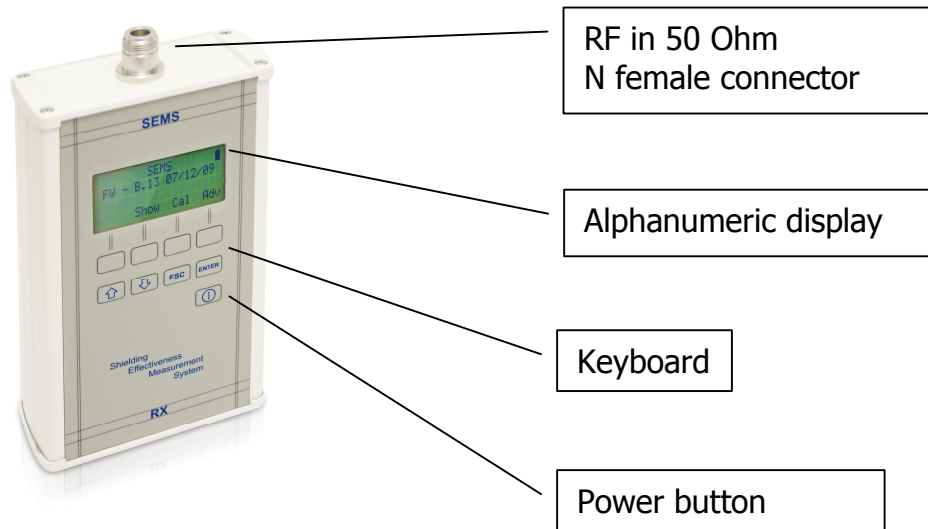

Picture n°03

1.6. Transmitter front panel

The SEMS transmitter (Picture n° 04) has no command button but a power button, since the commands are sent by the receiver using the wireless connection.

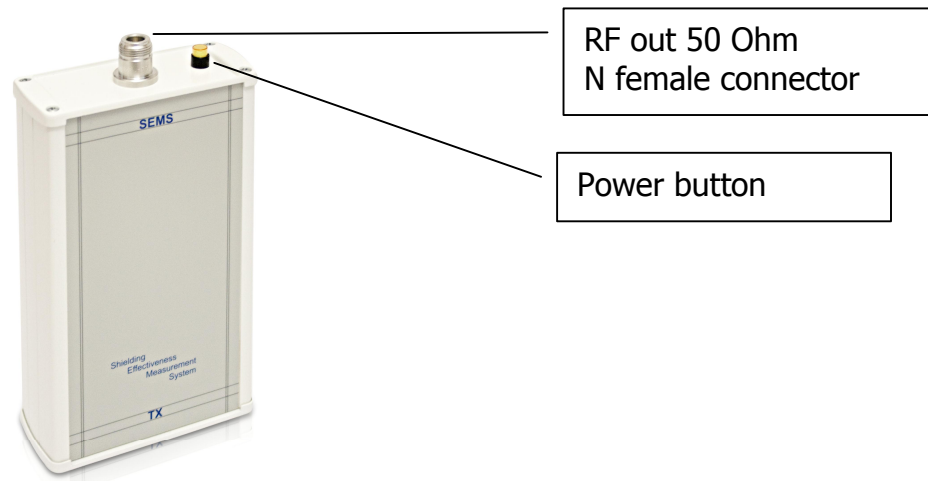

Picture n°04

1.7. Receiver / Transmitter rear panel

The rear panels (Picture n° 05) are the same for both devices and upon them is possible to find the serial number, the thread used for the tripod, the battery charger connector and the RS232 interface for the wireless link.

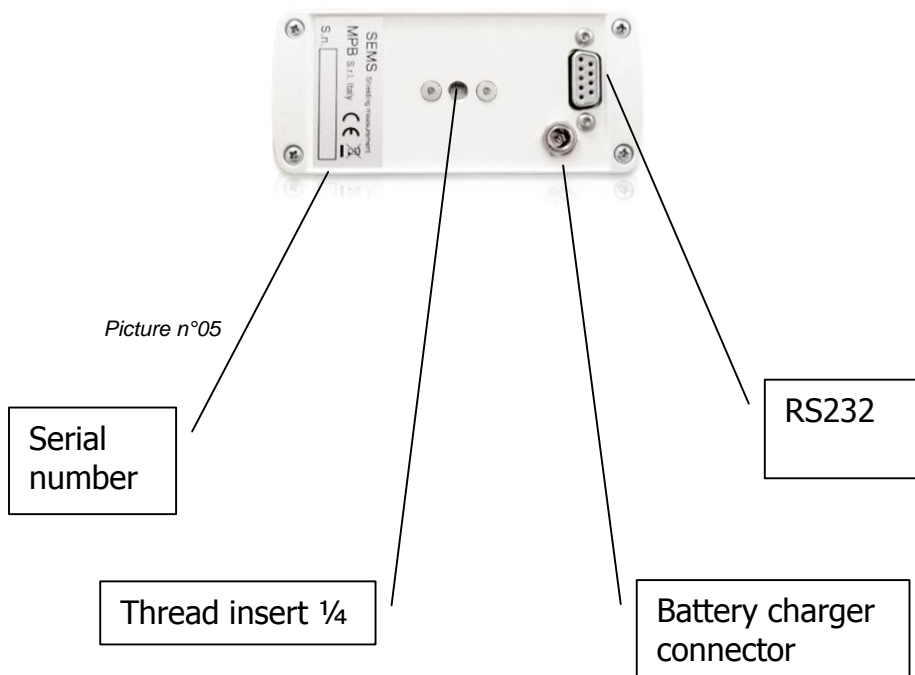

Important note: Always use the battery charger provided with the instrument to avoid serious damages to the devices and operator's injuries.

Important note: The battery charger must be connected to both devices (Tx and Rx) turned off.

1.8. Technical specifications

SEMS	
Frequency range for TX/RX	10 kHz...300 MHz
Resolution	10 Hz
RF out (TX module)	Z_{out} 50 Ω , N fem.
Max output power (typical)	+30 dBm
RF in (RX module)	Z_{in} 50 Ω , N fem.
VSWR	< 1.2
Attenuator	0...20dB
Max input power	110 dBuV
Dynamic Range	120 dB max
IF bandwidth (RX module)	
3 dB bandwidth	5/150Hz
Attenuation measurement accuracy (typical)	10 kHz...30 MHz \pm 1.0 dB 30 MHz...300 MHz \pm 1.5 dB
I/O interface	RS232 / Wireless
Buzzer	To set on attenuation level
International standard compliance	MIL-Std-285 IEEE Std 299 EN 50147-1 NSA65-6
Operating temperature	0°...40°C
Battery	Irreplaceable and rechargeable Li-Ion (6 h operating time)
Antennas	
Loop Mod.L1	Frequency range 2...128 MHz Diameter 30 cm
Biconical Mod. B1	Frequency range 60...300 MHz Width 35 cm
Calibration Set-Up and Measurement	Programmable with the software
Options	
Loop Antennas Mod.L2	Frequency range 10kHz...4 MHz Diameter 30 cm
Rod Antennas Mod. R1	Frequency range 1 MHz...60 MHz
Wooden tripod Mod. TR-02-A	Height settable
Optic link 30 m	
Weight and dimensions	
Overall weight	9,4 kg
Case dimensions	52x43x23cm

Technical specifications may change without notice

2. Operating principle

2.1. SEMS Receiver

The block diagram (a) below represents the SEMS receiver.

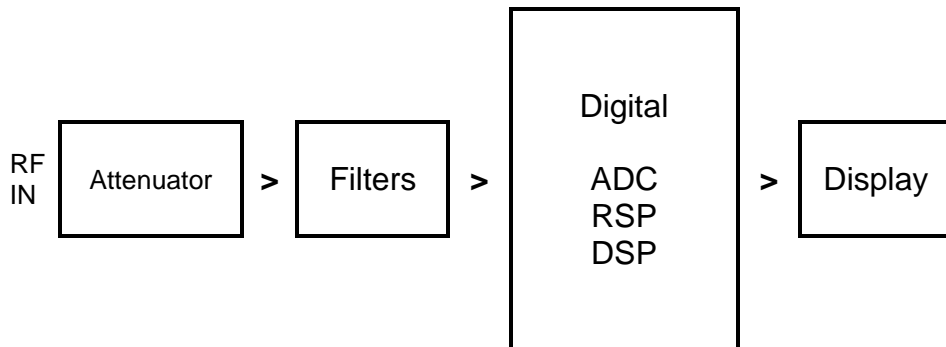

Figure a)

First of all the RF signal received by the antenna is attenuated by the attenuator module to fit the level to the next modules specifications, subsequently we can find the filters to select the bandwidth depending on the frequency settings. Then the RF signal is converted by an ADC and is processed by the digital part with a RSP and a DSP, the result will be shown on the display.

2.2. SEMS Transmitter

The block diagram below (b) represents the SEMS transmitter.

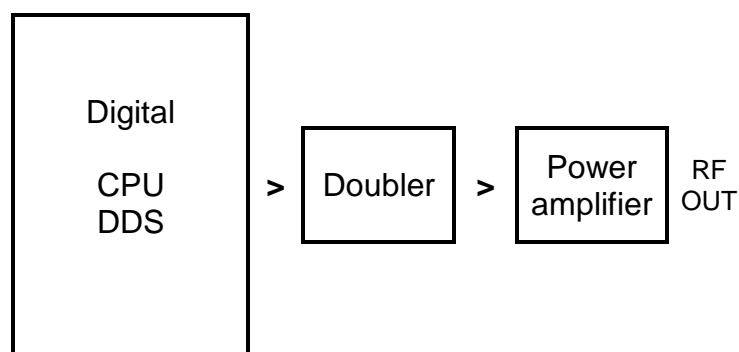

Figure b)

The transmitting signal is generated using the DDS controlled by the CPU that receives the instructions from the receiver wireless interface, this signal is duplicated and amplified in order to achieve the necessary level to be transmitted by the transmitting antenna.

2.3. SEMS System

The main purpose of the SEMS is to measure the shielding effectiveness in a shielded environment by measuring the attenuation of the electric or magnetic field.

We can briefly describe the operating principle as it follows:

The transmitter generates a RF signal and irradiates it through the antenna, at a certain distance the receiver catches the signal with an equal antenna and measures the signal level. If we move the receiver inside the shielded environment maintaining the same distance from the transmitter we will get a lower signal, so we can consider the shielding attenuation the difference between the reduced and the original signal.

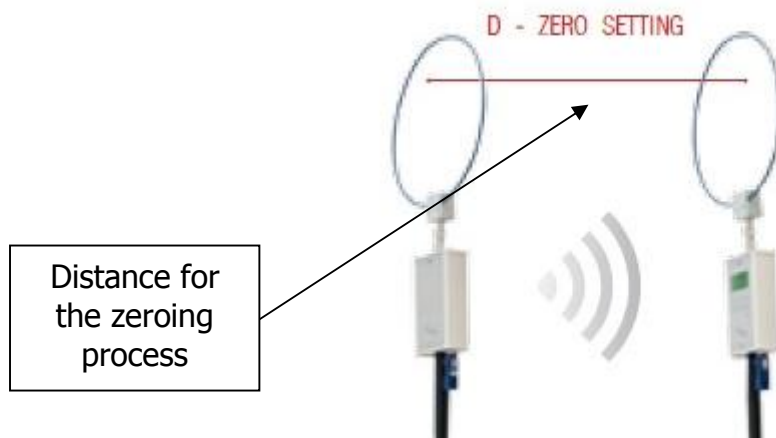

Picture n°06

Example of zeroing with loop antennas

3. System use and operations

3.1. Turn on menu

By pressing the power button of the RX module the device will turn on, to turn it off press the power button for at least 4 seconds. Follow the same procedure for the TX module.

As soon as the device is turned on, the display will show the following screenshot. On the top right of the screen will appear a battery icon to show the charge status of the RX module, then the TX connection on the top left will appear the TX device battery icon.

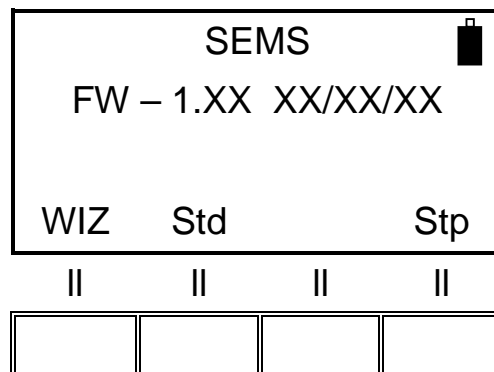

NOTE: As soon as the connection is established, if the red led of the wireless devices blinks together with the yellow ones, wait until the complete switching off of the first ones in order to let the devices synchronize and ensure the correct functioning.

3.2 Std Menu

By pressing the Std menu button this screenshot will appear

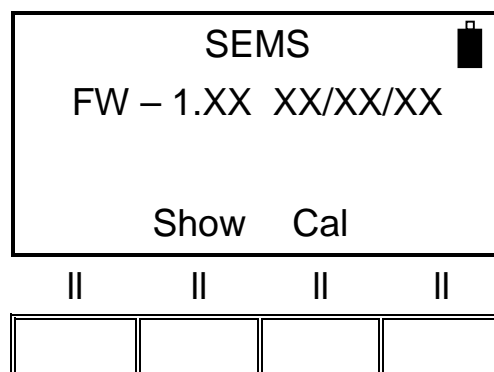

Then pressing the relative button allows the access to **Show** and **Cal** menu.

3.2.1. Cal Menu

Cal menu is used to perform the system zeroing process(Scan or List) or the system calibration process(CalK)

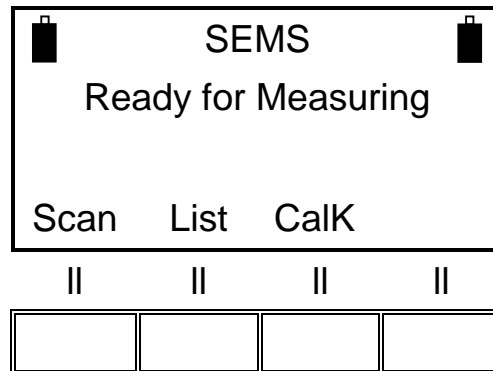

Scan performs the system zeroing process using the standard or customized frequency bands, by pressing the scan button we will see the following screenshot where is possible to choose the default bands (**L_Lo**, **L_Hi** e **Bic**) or the user's customized bands pressing the **User** button (customized bands are programmed with the "SEMS PC_Utility" software)

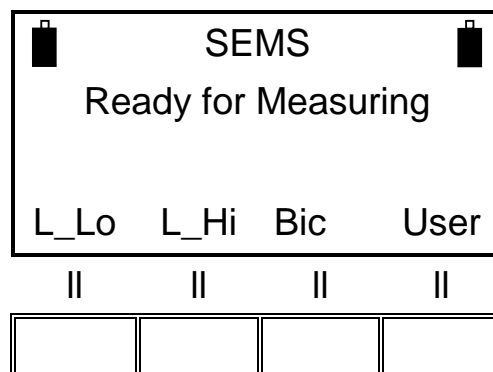

The choice of the button to press depends on the different types of antennas:

L_Lo (Loop antennas Mod. L2)

L_Hi (Loop antennas Mod. L1)

Bic (Biconical antennas Mod. B1)

By pressing the **User** button will appear the screenshot to choose the memorized band:

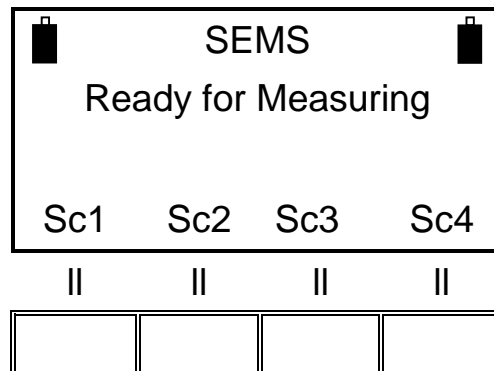

List performs the system zeroing process using the default or programmable frequency list, by pressing the list button will appear a new menu where you can select the default frequency list **DFT** or three programmable lists (**L1**, **L2** e **L3**)

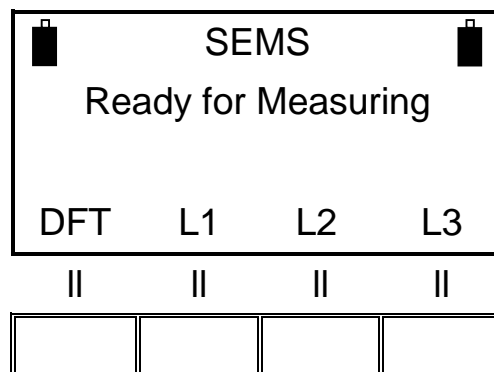

CalK performs the system calibration process using the four 30 dB attenuators supplied in the CAL-KIT.

NOTE: This procedure needs a wireless connection between TX and RX, you can control the connection with the battery status on the left top of the screen of RX (will be visible only if the connection has been successful).

When the zeroing procedure ends the following menu will appear:

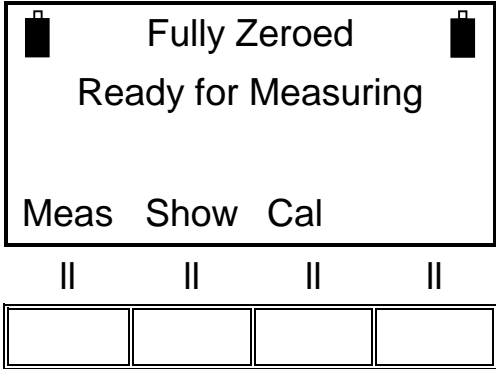

3.2.2. Show menu

The show menu will provide the results of the measurements performed and previously stored

To see the saved measurements press the Show button

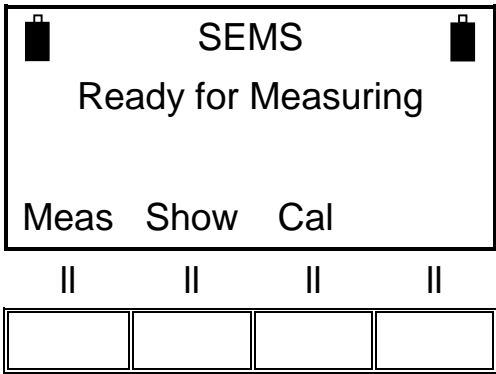

e.g. We will choose a measure stored in a memory named H1-4

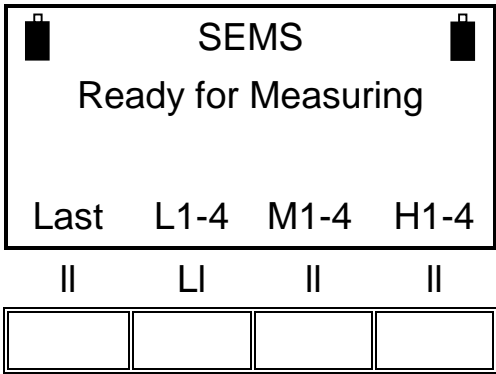

Then we recall the H1 memory

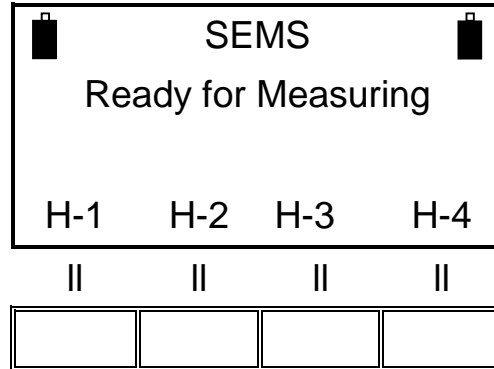

1stF Shows the attenuation at the lower frequency of the selected scan or list

NxFr Shows the attenuation on the next frequency

HiPk Shows the minimum attenuation on the whole scan or list

NxPk Shows the first relative minimum of attenuation from the current frequency

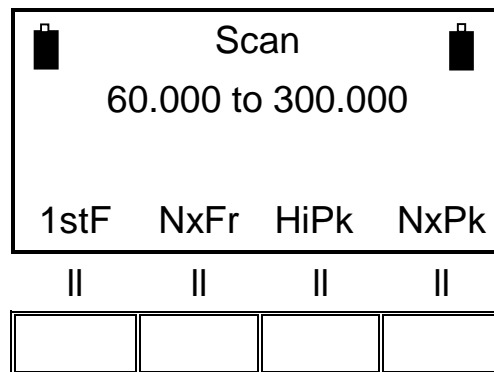

By pressing the **Last** button you will see the results of the last measurement performed, by pressing the remaining three buttons you can see the other stored data. (up to 4 for each button).

As soon as you choose the measure to see you can analyze frequency by frequency the measured attenuation. (The frequencies are always expressed in MHz)

By pressing the **ESC** button you can go back to the previous menu.

3.2.3. Meas menu

You can find the **Meas** command in the **Std** menu, but it will appear only when the system is zeroed using the **Cal** command described in the previous paragraph (3.1.1. of this manual).

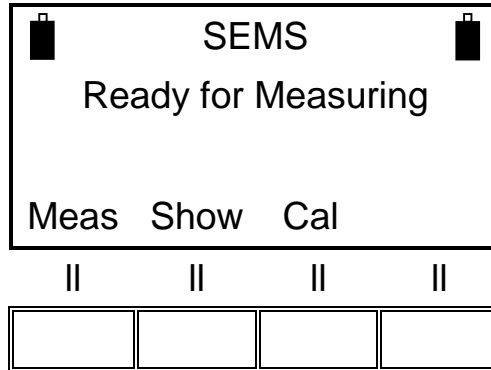

The command will perform a measurement of attenuation automatically (**Auto**), or manually (**Man**).

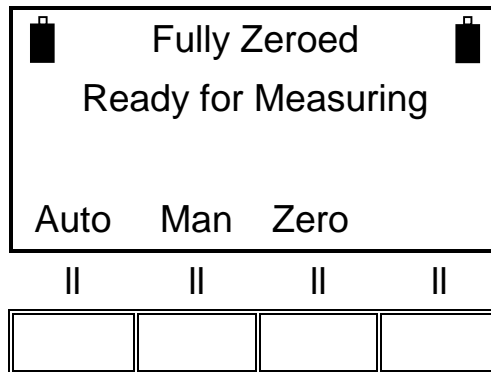

Using the automatic mode you can choose if you want the measurement procedure to start immediately (**Now**), or with a fixed time delay (**10s, 30s, e 60s**).

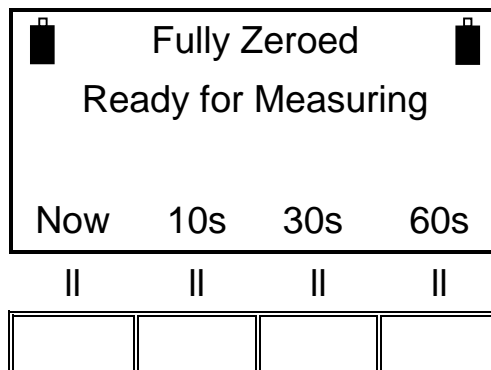

If you use a manual measurement you will use the commands: **(Prev)** measure of the previous frequency, **(Next)** measure of the next frequency, **(Redo)** in order to measure the current frequency and **(Abort)** to end the measurement.

This feature can be used as a modality of RF leaks(sniffer) in order to identify weaknesses in the shielding of the room. TX unit has to be placed approximately at 1 meter from the area analyzed. (For leaks measurements see the specific application note). To measure the electrical component we recommend to use Rod Antennas ,Mod. R-1, completely closed on the RX unit and completely open on the TX unit. For the magnetic field you can use the pairs of Loop Antennas L-1 or L-2.

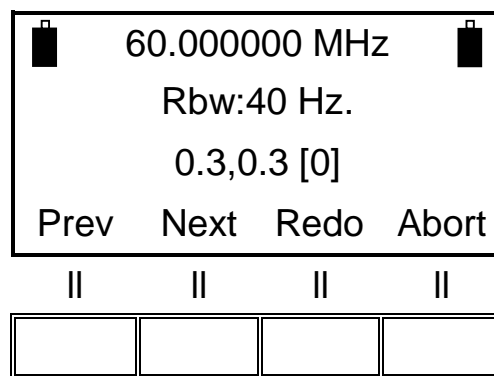

When the measurement is finished the display will show the memory slot to store the acquired data, you can choose one of the 4 memories for each frequency range:

- Frequency Range from 0.01 to 2 MHz = memory **(L-1, L-2, L-3 e L-4)**
- Frequency Range from 2 to 60 MHz = memory **(M-1, M-2, M-3 e M-4)**
- Frequency Range from 60 to 300 MHz = memory **(H-1, H-2, H-3 e H-4)**

Example: Save request in the memory slots from 60...300 MHz range:

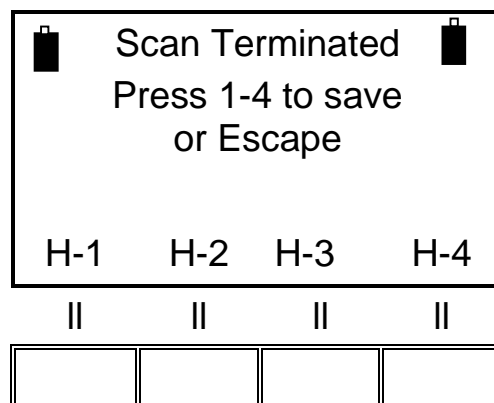



By pressing the H-1 button the data will be stored and you will go back to the starting screenshot.

3.3. WIZ menu



To improve the management of the measurement saving procedure you can use the SEMS's wizard for a better organization of data storage.

To use the wizard press the **WIZ** button in the top menu of the device. The wizard will lead the user throughout the procedure asking the following questions:

- The selection of the chamber where the measurements are performed (A, B, C, D): Using A, B, C e D you can identify a shielded chamber. Then the user has to remember the letter assigned to the chamber where the measurements were done.

		Choose the Chamber you want To measure		
	A	B	C	D
	<input style="width: 40px; height: 20px;" type="text"/>	<input style="width: 40px; height: 20px;" type="text"/>	<input style="width: 40px; height: 20px;" type="text"/>	<input style="width: 40px; height: 20px;" type="text"/>

- Choice of the maximum number of spot to be measured (1, 2, 4, 8): Represents the number of measuring spot assigned for each chamber. The user must sort chronologically the measured spot and he will find the same order in the instrument memory.

		Select the max number of spot to be measured		
	1	2	4	8
	<input style="width: 40px; height: 20px;" type="text"/>	<input style="width: 40px; height: 20px;" type="text"/>	<input style="width: 40px; height: 20px;" type="text"/>	<input style="width: 40px; height: 20px;" type="text"/>

- The selection of ranges (antennas) to be measured (1, 2, 3, 4): it represents the number of antennas systems available to the user during the measurements. When you perform the measurements at all the points specified previously, the system will switch range, asking you to replace the antennas and redo the auto zero procedure.

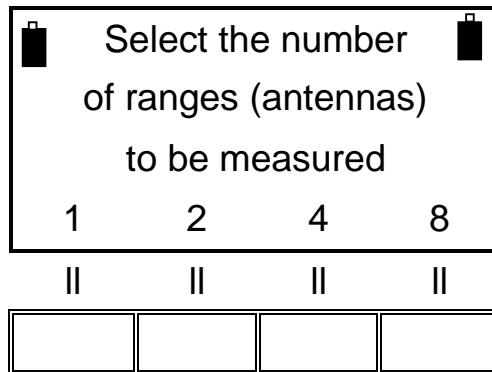

3.3.1. Measurement using wizard

After the selection of the chamber, spots and ranges the instrument will start the procedure to perform the auto zero required by the first set of antennas to be used.

The procedure to follow for this purpose is exactly the same of the auto zero calibration as described in chapter 3.1.1. of this manual.

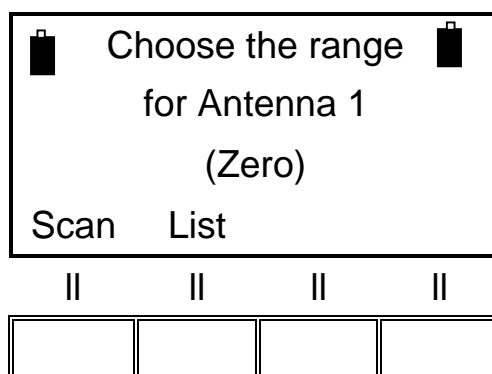

Selecting "Scan" we can choose to zeroing the system using the default mode (L_Lo - L_Hi - BIC) or to use the span programmable by the "SEMS PC_Utility" software mode (User).

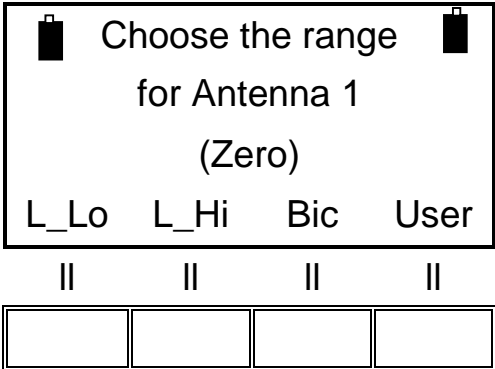

As soon as the zeroing procedure is completed, the measurement screenshot will appear on the display.
 In this screenshot the user has to decide how to perform the measurements: automatically (**Auto**), or manually (**Man**).

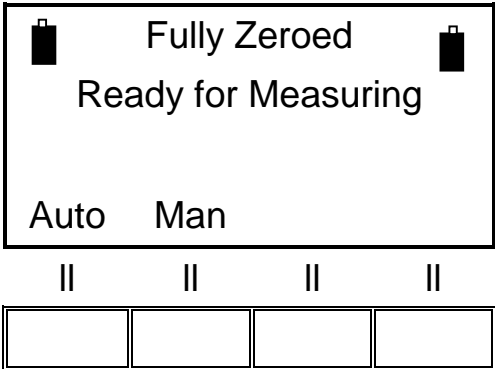

Choosing the automatic mode we can make it start immediately (**Now**), or set a fixed time countdown before starting (**10s**, **30s**, **e 60s**).

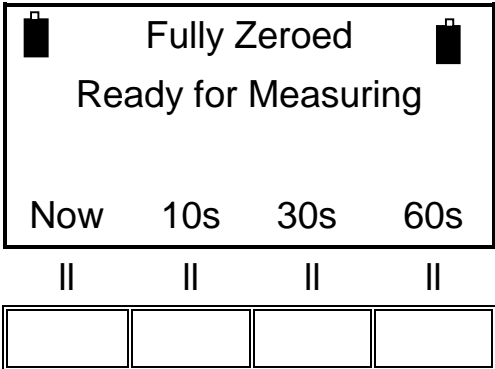

When the manual mode is selected , the user has to choose the commands: (**Prev**) to measure the previous frequency, (**Next**) for the next frequency, (**Redo**) to repeat the measurement on the current frequency or (**Abort**) to quit.

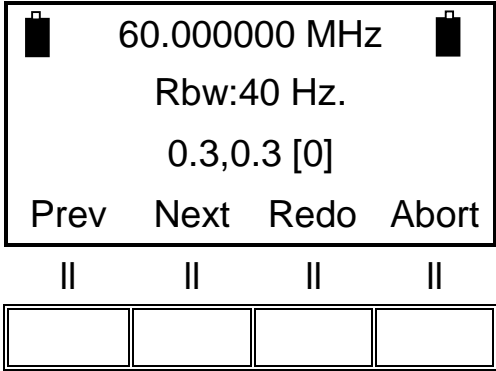

After this choice the measurement will be performed, and will appear the wizard management screenshot to control the status of the procedure.

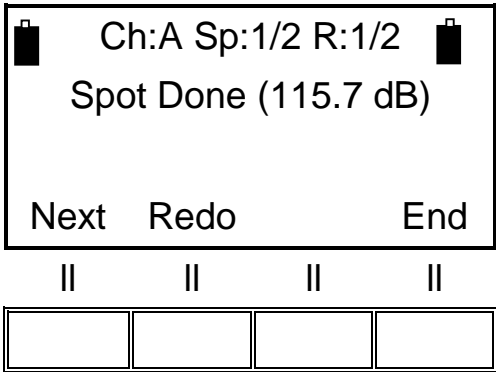

In this screenshot “Ch:A” means that the chosen chamber is called “A”, “Sp:1/2” is the measurement spot index (in this case the spot is the 1st of the 2), “R:1/2” is the antennas system (range) that we are using (in this case we are using the first system of the 2).

“Spot Done” means that the measurement is completed for this spot with the indicated range, the value shown nearby beneath brackets is the maximum attenuation of the whole frequencies.

The **Next** button must be pressed to get to the next spot. If all the required spot have been measured, the procedure automatically switches to the next pair of antennas and shows again the auto zeroing screenshot. If you used all the antennas systems that you selected , the procedure is over and it will return to the main screenshot with a success message about the data storing.

The **Redo** button repeats the measurement for the selected spot shown in the screen, as soon as this operation is completed the display shows the same screenshot with the updated value of the maximum attenuation.

The **End** button stops the measurements with the current set of antennas. By pressing it the instrument will ask us to change the antennas and to start the auto zero procedure, if the antennas systems have all been selected the procedure will end with a message of success about the storing of the data and you will go back to the main screenshot.

WARNING: Pressing the “End” button in the first antennas system will reduce the spots for all the other systems. (e.g. if I select 8 spots and I measure just 3, pressing end will reduce to 3 the maximum number of spot per system. But if we perform a measurement on all of the 8 spots, then we will change antennas, and then again we will press the end button after just 3 spots measured and all the 5 spots will be kept.

3.4. STP Menu

SEMS has an internal buzzer that beeps every time that a customizable alarm threshold is exceeded.

To activate this function you have to press the “Stp” button in the main screenshot shown as you turn the instrument off.

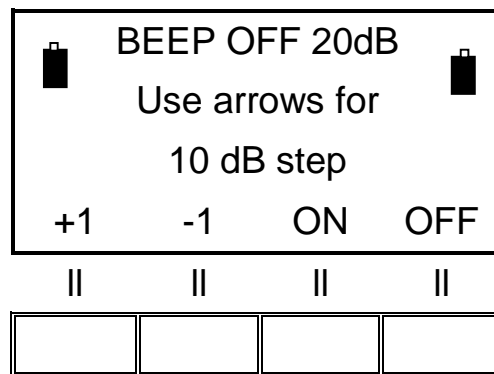

Using the up and down arrows on the SEMS keyboard is possible to move the threshold to 10 dB, to set a more fine value is possible to press the **+1** and **-1** buttons to increase or decrease the threshold to 1 dB.

By pressing the **ON** button the buzzer will be activated, and during the measurements if the attenuation measured drops below the threshold the buzzer will produce an acoustic signal.

While the measured value remains under the threshold the buzzer will produce a fast series of beeps, when the measured value returns over the threshold the buzzer will be still beeping but with a slower series of sounds.

The **OFF** button will take the sound off.

The sound mode status is reported on the top of the display in this menu “BEEP ON” and “BEEP OFF”.

The actual threshold is written on the right top of the screen (in this example is 20 dB)

3.5. Measuring the shielding attenuation

- 1) Place the receiver and the transmitter on the non conductive tripods (height 120 cm), and place them at a distance of 40/60 cm if you are using the loop antennas and 100/200 cm if you are using biconical ones.
- 2) Connect the antennas upon the transmitter and receiver being careful to align them in a parallel way.
- 3) Connect the wireless transducers to the RS232 port on the transmitter and the receiver, turn on both devices and wait until the green blinking light stops and remains turned on and the two icons of the batteries become visible on the receiver's display. It is recommended to wait a few minutes before going on (warm-up).
- 4) Perform the zeroing procedure by using the **Cal** button, then select **Scan** or **List** for the desired frequencies.
- 5) As soon as the zeroing procedure is over move the receiver into the shielded environment near the first measurement point and the transmitter outside trying to maintain the same distance used during the zeroing plus the shield width.
- 6) Measure the attenuation pressing the **Meas**, **Auto** and **10s** button to allow the user to walk away from the measuring system.
- 7) As the measure ends save the result in a memory.
- 8) Repeat the 5, 6 and 7 steps for each measurement spot.
- 9) After all the spots are measured download the results on a PC using SEMS PC Utility software provided with the product.

3.6. Calibration using Calkit

The SEMS needs a periodic linear calibration, the Cal-Kit can easily and precisely accomplish this purpose. If required the Cal-Kit can be provided with SIT calibration.

To start the calibration procedure press **Std/Cal** button from the main menu and press **CalK** button, then calibration can be performed following the instructions on the display.

This screenshot shows the request for the 30 dB attenuator

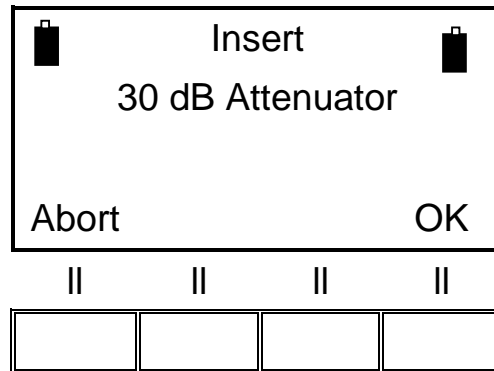

Connect the Tx and Rx using the 30 dB attenuator and press the OK button

This screenshot shows the request for the second attenuator

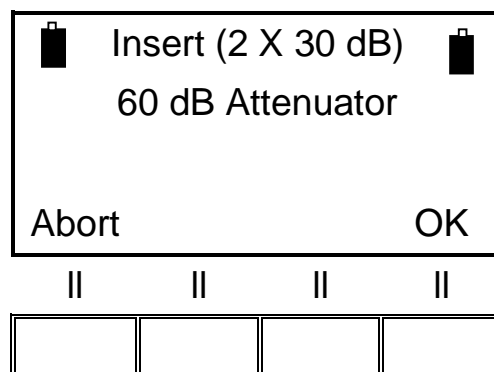

Connect the second attenuator and then press the OK button

Repeat the same operation until you will use all the four 30 dB attenuators (4x30 dB= 120 dB)

When the calibration is done the following screenshot will be shown

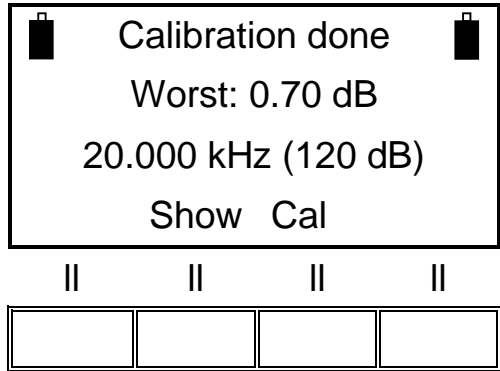

The “Worst” parameter shows the worst accuracy over frequencies (in this case is 0.7 dB at 20.000kHz) typically is a parameter that you can find in the technical specifications of the chamber:

10 kHz... 30MHz ± 1.0dB
 30 MHz...300MHz ± 1.5dB

The following image show the procedure set-up.



Picture n°07

3.7. How to use the active bridge

The active bridge has been developed to improve the connection between Tx and Rx, this is very useful when the shielding that is tested is too high to ensure the direct wireless connection between the devices (2.4GHz), using the wireless/optical cable adapter you can solve the problem allowing the regular performance of the test.

The active bridge consists in two wireless/optical fiber adapter modules called “wireless bridge master” and “wireless bridge slave”, the modules are connected through the optical cable, and powered by (Ni-Mh AAA) rechargeable batteries (the battery charger is included).

To set up the active bridge you have to turn on the wireless bridge master device and the module linked to the RS232/wireless adapter called “slave” and wait for their connection.

The next step is to turn on the wireless bridge slave device and the other module and wait for their connection.

In both cases the successful connection will be confirmed by the green light of the led steady on both modules.

As soon as the connection is established it's possible to check the battery status of the Tx on the Rx display.

The optical fiber which connects the master and the slave devices should pass under the door in a fingerless zone, if the finger does not allow the fiber placement, the proper channel located typically near the filter's panel should be used.

IMPORTANT NOTE: As soon as the connection is established, if the red led of the wireless devices blink together with the yellow ones, wait until the complete switching off of the first ones in order to let the devices synchronize and ensure the correct functioning.

On the active bridge devices there is no red led, just wait for the complete switching off of the red led on the TX/RX to ensure the proper functioning.

3.8. Measurement with Rod antennas mod. R1

When using Rod antennas(in the zero setting and in the measurement phase) it's absolutely necessary to connect the SEMS TX 10 dB attenuator ,already supplied, before connecting the Rod antenna (image n.08)

WARNING: not using the attenuator can cause serious troubles to the system functionality.



Picture n°08

4. SEMS PC Utility software, controls and functions

4.1. Installation

Insert the USB Drive that came along with your SEMS system into the PC you are installing the software to.



Launch the setup file (SEMS SW.exe) and click **YES** in the pop up window (Vista and Seven users only):

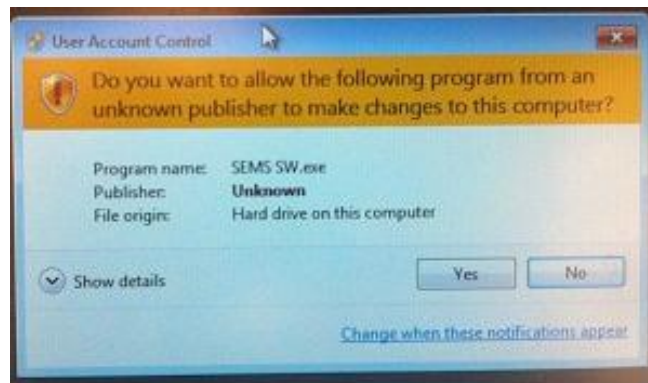

According to your computer settings, SEMS SW Installer will have on screen instruction in different language.



5.

6.

Follow the instructions on screen to complete the installation.

4.2. Options menu

SEMS PC Utility starts from the desktop icon or from **start / Programs**.

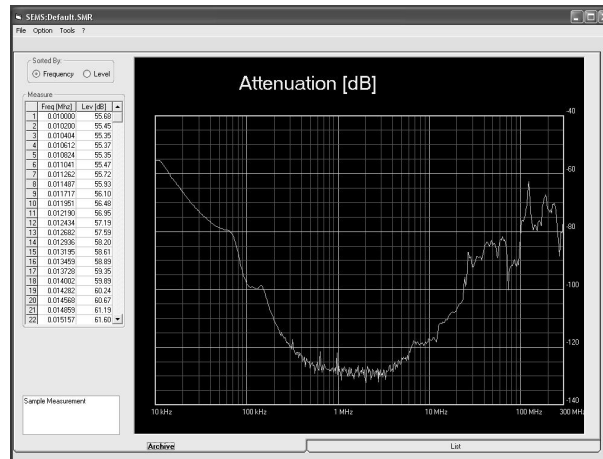

The program has two working modes: **Archive** shown in the program start up and **List**, in archive mode is possible to load files and show measurements, in the list mode is possible to create and send to the receiver the list of frequencies for customized measurements.

4.3. Archive Mode

Menu:

File

- Save* Saves the files in the chosen directories
- Load* Loads the files from the chosen directories
- Export* Exports data in file.xls with two available data separators
- Exit* Quits the program

Option

- Select Comm* Selection of the com serial port
- Graphic colors* Changes the graphic colors
- Diagram style* Selection of two ways of representing the data diagram
- Default Graphic Axis* Restore the default graphic visualization

Tools*Retrieve*

Single measure: Retrieve the stored measurements made in standard mode (Std) from the receiver using RS232 connection

Set of measure: Retrieve the stored measurements made by the wizard (Wiz) using RS232 connection

Get CalK Report: Produces a text file containing the last calibration data performed using the CalK procedure. (You can find CalK_Report.TXT file in the folder where you installed SEMS PC Utility Software)

Update Firmware Updates the receiver's firmware

In the Archive mode you can see on the left side of the window the numerical results that can be sorted by frequency or dB level, in the box below you can add a comment when saving the data.

You can change the scale by double clicking on the maximum and minimum value in the graphic.

(*) In addition to RS232 connection, you can connect the SEMS receiver to the PC using the wireless device, the connection takes place between the SEMS receiver wireless and the PC wireless.

4.4. List mode

Clicking on the **List** button, on the right bottom of the window, the second working mode will be activated.

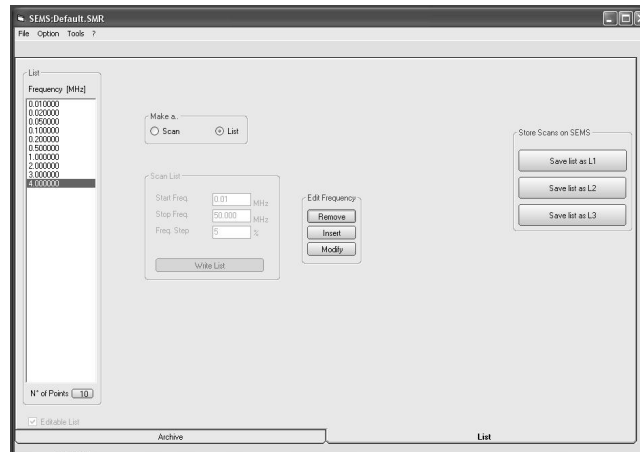

Here you can find how to create a frequency list to upload in the SEMS as customized frequencies:

For an automatic table creation press the **Scan** button setting **Start Freq.** , **Stop Freq.** and **Freq. Step** or **Write List** or **List** to insert manually any kind of frequency. The maximum number of frequencies allowed for each scan or list is 640.

In order to edit a scan you need to activate the **Editable List** flag.

As the table creation is completed is possible to save on the PC pressing the **Save** button or uploading it to the receiver choosing one of the four available memories in scan or three available memories in list.

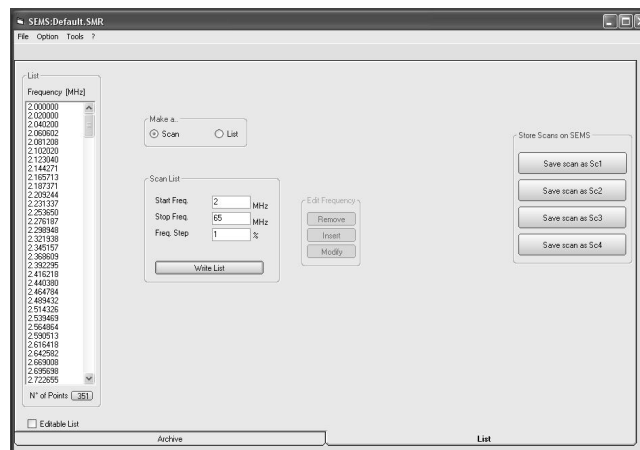

4.5. Receiver firmware upgrade

Recharge the receiver batteries and connect it to the PC using RS232 cable. Turn on the Rx, run the SEMSPC_Utility software and set the COM port in the Option menu pressing Select Comm.

To verify the assignation of the COM port assigned by the PC check in the control panel, System, Hardware, peripheral, ports.

To start the firmware update procedure, click the “Tools” button , Update Firmware, Update Rx.

The following screenshot will appear:

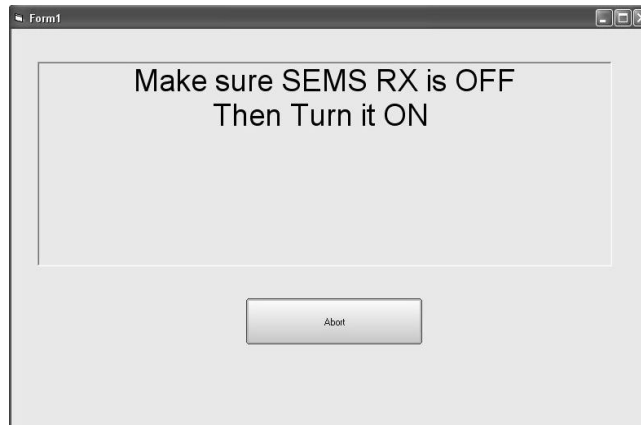

Turn off the receiver and then turn it on again.

It will show the upgrade window:

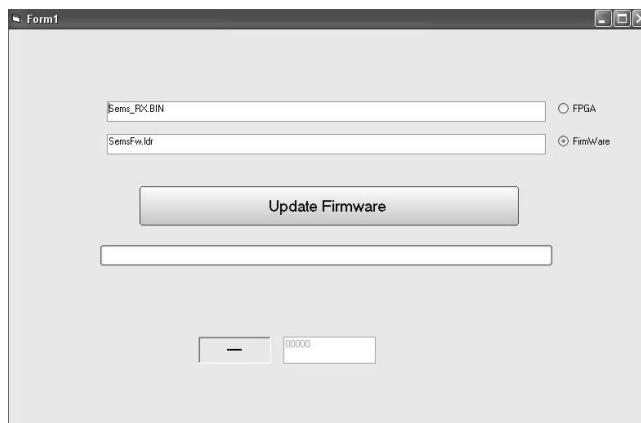



The updatable file (SemsFw.ldr) should be located in the SEMS software directory. Press the "Update Firmware" button and wait for the loading. When the upgrade is completed, close the "Form1" window and turn off the receiver.

Other information: www.gruppompb.com

Technical information: assistenza@gruppompb.com

Phone +39 06 41200744