



# **BC 2000 DIGITAL**

Audio Routing, Mixing and Processing System for  
Program Production Centers

## **DESCRIPTION OF THE EQUIPMENT AND ITS PARTS**

**ED 02/10**

V 1.0 - 08/02/2010

### IMPORTANT NOTE

In order to ensure a good operation of BC2000D system a simple maintenance must be done.

There are 10 fans located on the top of the BC2000D system chassis that must be kept clean. We recommend to check fans operation at least once a year.



It's also important to keep clean the air holes of rear boards and front cover, as well as the boards connectors.



## CONTENTS

1. INTRODUCTION: ORGANIZATION OF BC2000D SYSTEM MANUALS.....	4
2. THE RACK AND ITS PARTS.....	5
2.1. BC2000DF. System rack.....	5
2.2. BC2201. Analog line input/output module.....	7
2.3. BC2202. AES/EBU digital input/output module.....	10
2.4. BC2203MH. Analog MIC/LIN input and headphone output module.....	13
2.5. BC2203M. Analog MIC/LIN input module.....	16
2.6. BC2204. Analog line input module.....	18
2.7. BC2205. Analog line output module.....	20
2.8. BC2206. AES/EBU digital input module.....	22
2.9. BC2207. AES/EBU digital output module.....	25
2.10. BC2208. Analog line input/output module with transformer balanced inputs.....	28
2.11. BC2209. 8 Analog line input/output module.....	30
2.12. BC2211. AES 10 MADI module for linking racks.....	32
2.13. BC2212. Dual AES 10 MADI module for linking racks.....	34
2.14. BC2220 and BC2221. DSP board. Processing, routing and VU meters.....	36
management.....	
2.15. BC2240. Master Controller Module with USB, Ethernet and RS232/422 port....	38
2.16. BC2250. Front control panel.....	42
2.17. BC2290. 2x300W Power Supply.....	44
2.18. BC2291. 350W Power Supply.....	46
2.19. BC2292. 200W Power Supply Module.....	47
3. STANDARD WIRING SYSTEMS FOR BC2000D SYSTEM.....	49
3.1. Individual connection components.....	49
3.1.1. BC 2000 CAB RACK chassis.....	49
3.1.2. BC 2000 CAB W connection modules.....	50
3.1.3. RJ45 to 4 XLR connection modules.....	51
3.1.4. Cables with connectors.....	52
3.1.5. Loose cables and connectors.....	52
3.2. Wiring kits for BC2000D system.....	53
3.2.1. Standard wiring kit.....	53
3.2.2. Additional control wiring.....	55
4. SWITCH.....	56
5. CONTROL SURFACES.....	57
5.1. ARENA DM control module.....	58
5.2. ARENA D10 channel expansion module.....	60

## 1. INTRODUCTION: ORGANIZATION OF BC2000D SYSTEM MANUALS.

More than just a product, the **BC 2000 D** is a **System** that must be known at different levels by different types of technicians and users. This is why the information we are providing you is structured in different documents, oriented to different professional profiles.

1. **BC 2000 D console catalog.** For all professional profiles involved in the purchase and use of the BC 2000 D as a mixing console: prescriber, installer, technical manager, administrator and user.
2. **BC 2000 D matrix catalog.** For all professional profiles involved in the purchase and use of the BC 2000 D as a switching matrix: prescriber, installer, technical manager, administrator and user.
3. **Manual “Description of the Equipment and its Parts”** (this manual). For the professional profiles involved in the installation and technical knowledge of the BC 2000 D as a mixing console or switching matrix: prescriber, technical manager, installer and administrator.
4. **ARENA DM control surface User’s Manual.** Aimed directly at the user of the BC 2000 D as a mixing console, although this manual should also be known at a more basic level by the rest of the professional profiles involved with the BC 2000 D as a mixing console: prescriber, installer, technical manager and administrator.
5. **Configuration software for the BC 2000 D mixing console User’s Manual.** This is the fundamental tool for the administrator, and is also highly useful for the mixing console prescriber, installer and technical manager.
6. **Firmware upgrade software User’s Manual.** This is a tool meant specifically for the installer and maintenance technician, it can also be used by the administrator under technical department supervision.
7. **Configuration software for the BC 2000 D matrix User’s Manual.** In the use of the BC 2000 as a switching matrix, the demarcation of roles between technical and user profiles is not that clear. Therefore, this manual and the next one should be known by the various technical profiles involved; in some cases, some material can be extracted from the user’s manual for the benefit of low-level users.
8. **Real Time Control software for the BC 2000 D matrix User’s Manual.**

## 2. THE RACK AND ITS PARTS.

### 2.1. BC2000DF. System rack.

#### General description.

This is the chassis that houses the BC 2000 D system printed circuit boards. It is 4 units high and 19" deep. The backpanel, the TDM bus terminal board and the system cooling fans are integrated into the rack.

#### Composition of the supply.

- Rack with the relevant boards.
- 4-meter speakon/speakon power supply cable.
- 1-meter flexible, shielded, uncrossed local network cable (for connection through switch).

#### Description of the panels.

The **front section** has 21 slots. The first of these ("A" in the figure below) must be occupied by a load termination board, and the next 20 slots ("B") can accommodate up to 20 DSP boards (**BC2221**). At the right-hand end of the rack ("C") a **BC2250** front control panel could be placed: when this front module is mounted in the system, the rack can accommodate up to 18 DSP boards.

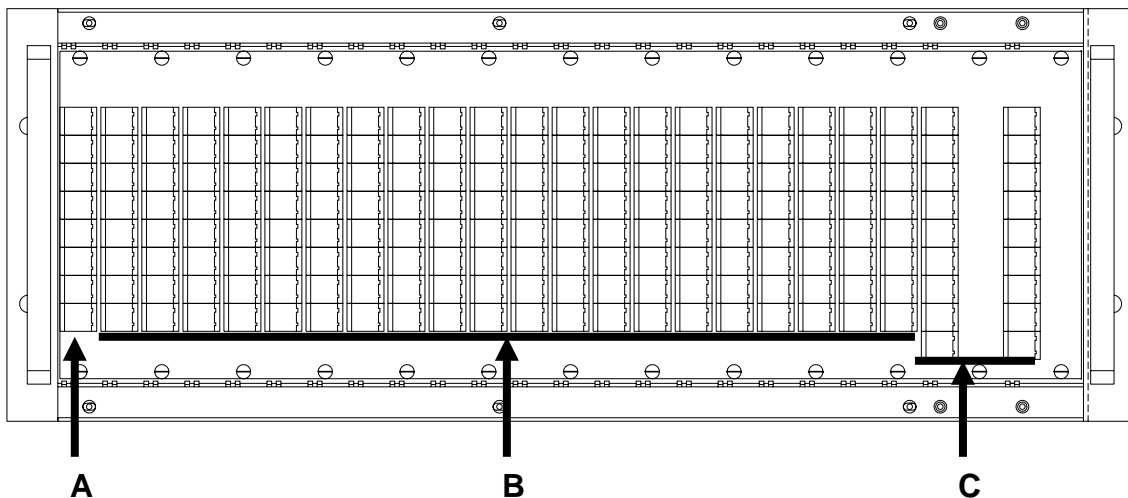

The **rear section** offers 21 slots (“D” in the drawing below) to house up to 16 input/output boards (BC2201, BC2202, BC2203, BC2204, BC2205, BC2206, BC2207, BC2208, BC2209, BC2211 or BC2212) and 1 or 2 power supply modules (BC2292). When there are no **BC2292** modules in the system, the rack can accommodate up to 21 input/output boards. There are two slots at the left end of the chassis (“E”) to house one or two **BC2240** controller modules.

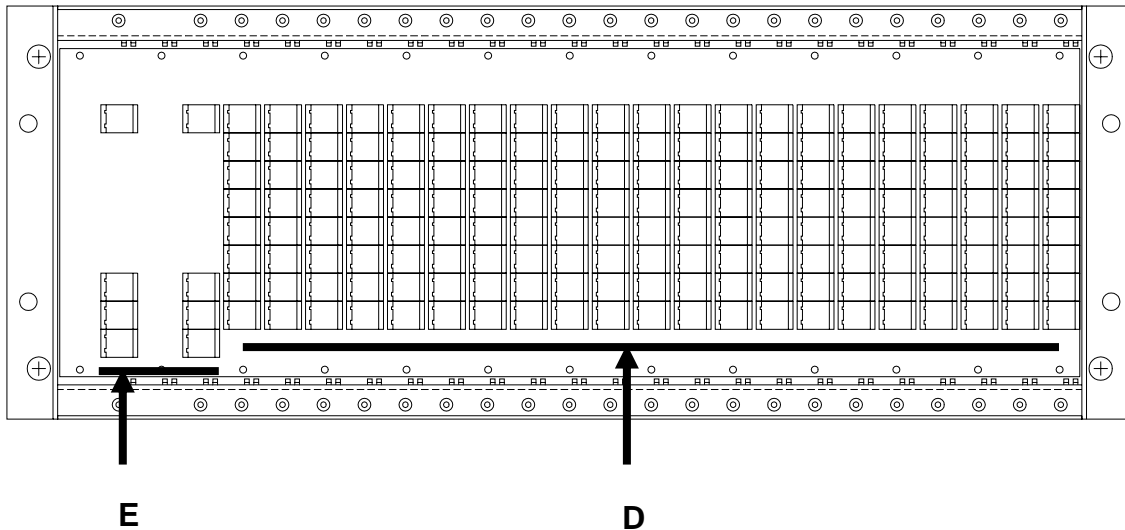

While the boards can be inserted in any position in the rack, we recommend, whenever possible, leaving an empty slot between each pair of boards inserted in the rear panel to facilitate connection and disconnection of the cables and ventilation.

**Other characteristics and features.**

The ventilator fans are mounted so that they can be hot-swapped. To be able to hot-swap the fans, the rack must be mounted on extractor rails.

The backpanel or connection board is completely passive, which eases maintenance. Backpanel breakdowns or failures are highly improbable and can only occur for mechanical reasons.

**Technical characteristics.**

Dimensions: 4 U x 19 “ (482 mm x 176 mm x 450 mm).

Approximate weight: 10,500 grams.

## 2.2. BC2201. Analog line input/output module.

### General description.

The BC2201 board can manage four TDM IN bus time-slots to insert two analog stereo (or four mono) signals into the system with line level, and four TDM OUT bus time-slots to extract two analog stereo (or four mono) signals from the system with line level.

This board is inserted into the rear part of the BC2000DF rack.

### Panel description.

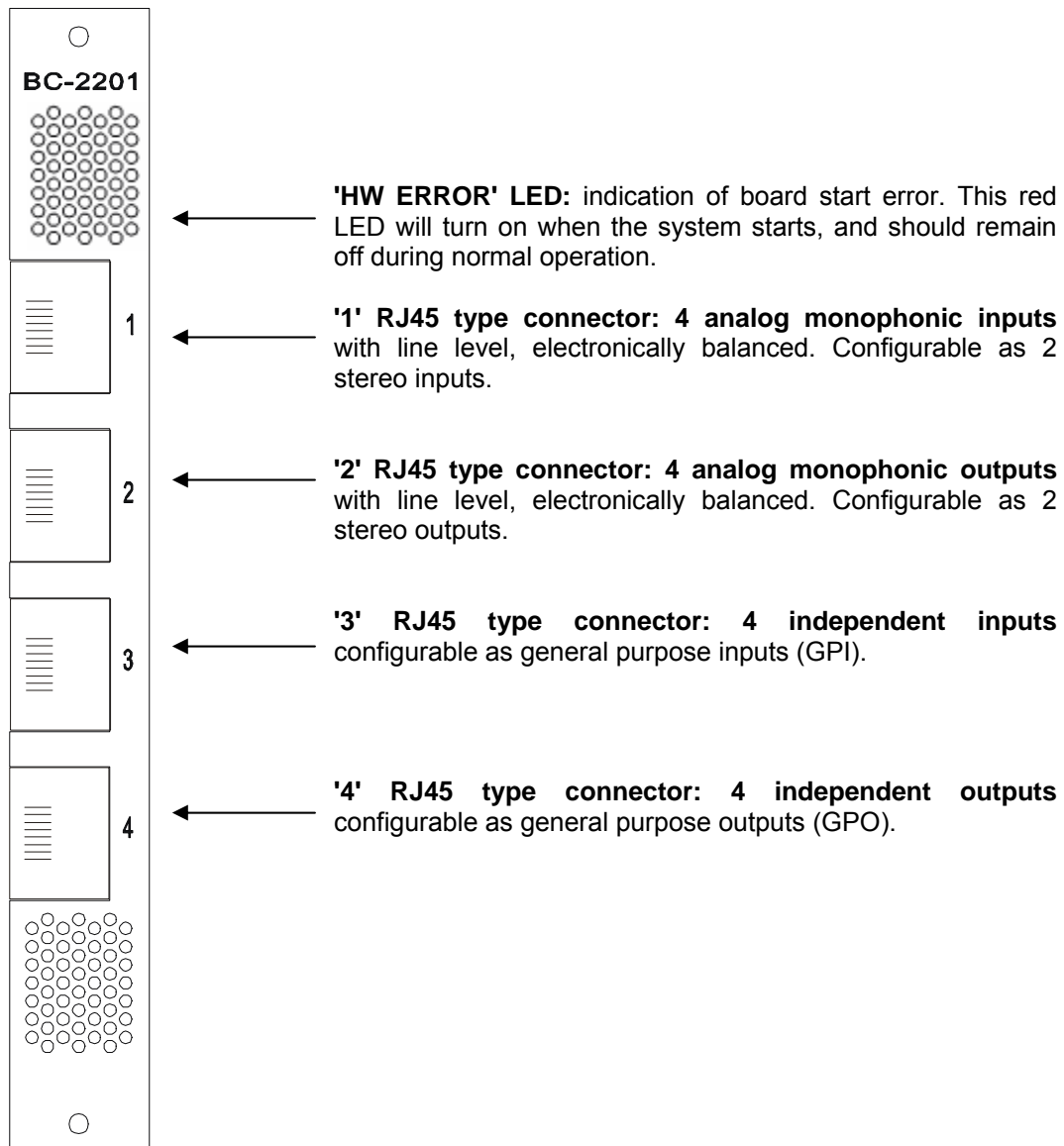

**Other characteristics and features.**

- Internal warning signal indicating a failure in one of the power supplies. If a failure occurs, the “ALARM” LED on the BC2240 controller board will light up.
- Power feed circuit designed to support hot-swapping operations.
- Digital adjustment of analog gain ( $\pm 12$  dB) in the 4 inputs and the 4 outputs.
- Digital adjustment of digital gain ( $\pm 12$  dB) in the 4 inputs and the 4 outputs.

**Programming jumpers.**

This board has a series of internal programming jumpers (PJ). However, these jumpers are configured at the factory and, in normal operation, do not need to be changed.

**Firmware modules.**

At the firmware level, this board is made up of the following modules:

- **PIC microcontroller:** manages board communications and start-up.
- **FPGA programmable device:** manages the converters and the TDM bus.

The firmware versions can be brought up to date by using the “**BC2000D Firmware Upgrade**” software application.

**IMPORTANT NOTE:** there is an specific firmware version for FPGA module when the BC 2000 D system is working as a switching matrix of 1024x1024 channels.

**Signal layout in the RJ45 connectors of the board.**

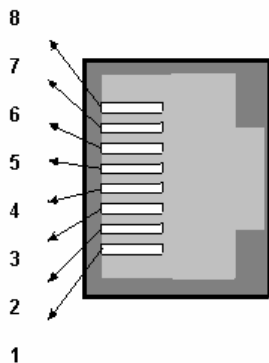

	'1' Inputs	'2' Outputs	'3' GPI	'4' GPO
8	IN 2 (1R) V-	OUT 2 (1R) V-	GND GPI2	GND GPO2
7	IN 2 (1R) V+	OUT 2 (1R) V+	GPI2	GPO2
6	IN 3 (2L) V-	OUT 3 (2L) V-	GND GPI3	GND GPO3
5	IN 4 (2R) V-	OUT 4 (2R) V-	GND GPI4	GND GPO4
4	IN 4 (2R) V+	OUT 4 (2R) V+	GPI4	GPO4
3	IN 3 (2L) V+	OUT 3 (2L) V+	GPI3	GPO3
2	IN 1 (1L) V-	OUT 1 (1L) V-	GND GPI1	GND GPO1
1	IN 1 (1L) V+	OUT 1 (1L) V+	GPI1	GPO1
Rack	AGND	AGND	AGND	AGND

**BC2201 technical specifications.**

Analog inputs:

- 24-bit, 48 kHz A/D converters.
- Nominal input level: +4 dBu (software configurable).
- Maximum input level: +22 dBu.
- Minimum input level: -20 dBu.

Analog outputs:

- 24-bit, 48 kHz D/A converters.
- Nominal output level: +4 dBu.
- Maximum output level: +28 dBu (+22 dBu with nominal adjustment).
- Output stage noise level: -82 dBu.



General audio specifications:

- Bandwidth: 20 to 20,000Hz +/-0.8 Db.
- Distortion: less than 0.09% in the bandwidth.
- Input + output noise level (in audio frequencies): -76 dBu.
- Cross-talk: less than -70 dB in the bandwidth.

GPI inputs:

- Inputs protected by optocoupler (4N35).
- Maximum input current: 60 mA.
- A voltage ranging from 5 V to 30 V will be applied.

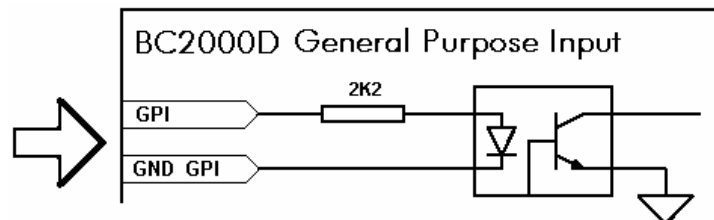

GPO outputs:

- Outputs protected by optocoupler (TLP371).
- Maximum current: 80 mA.
- Recommended maximum voltage: 200 V.
- Maximum power: 250 mW at 40° C.
- Requires external power supply.

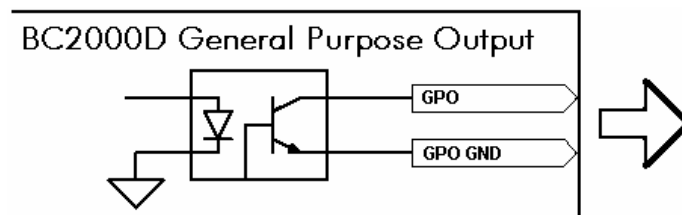

General characteristics.

- Approximate consumption: 9 watts.
- Approximate dimensions:  
Front: 17 x 172 mm.  
Depth: 255 mm.
- Approximate weight: 315 grams.

Characteristics are subject to change without notice.

## 2.3. BC2202. AES/EBU digital input/output module.

### General description.

The BC2202 board can manage eight TDM IN bus time-slots to insert four AES3 (or SPDIF) digital stereo signals into the system, and eight TDM OUT bus time-slots to extract four AES3 (or SPDIF) digital stereo signals from the system.

This board is inserted into the rear part of the BC2000DF rack.

### Panel description.

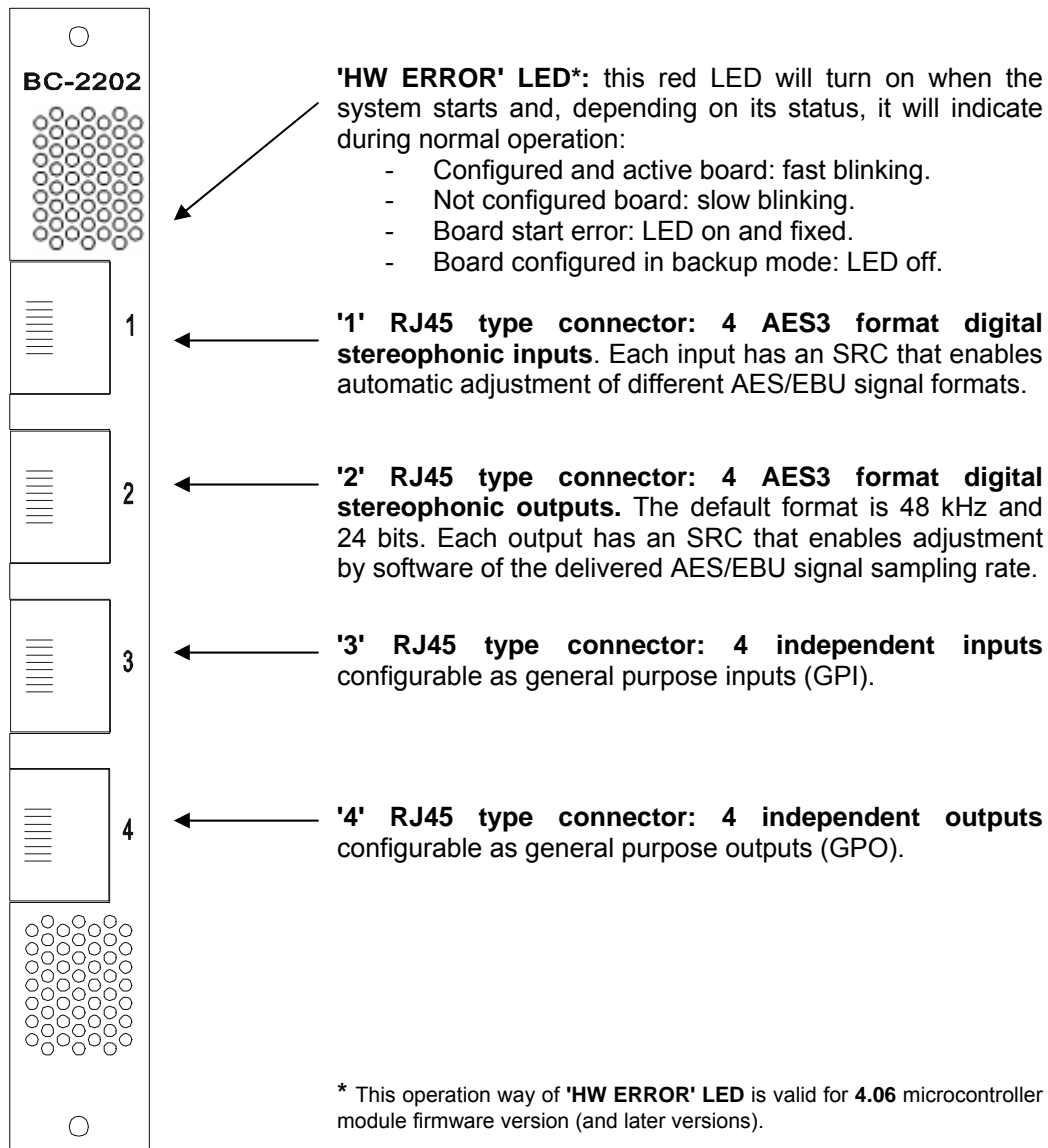

### Other characteristics and features.

- Internal warning signal indicating a failure in one of the power supplies. If a failure occurs, the “ALARM” LED on the BC2240 controller board will light up.
- Power feed circuit designed to support hot-swapping operations.
- Digital adjustment of digital gain ( $\pm 12$  dB) in the 4 inputs and the 4 outputs.
- Possibility of converting the module so that it can use SPDIF signals by manipulating the internal programming jumpers.

### Programming jumpers.

This board is equipped with a series of internal programming jumpers (PJ) that allow you to change the format of the digital signal to be used between AES3 and SPDIF. You can independently change the format of each one of the four audio channels (circuit 0, 1, 2 and 3) by changing the following PJs:

**CN12, CN13, CN16, CN18, CN22** → AES3 / SPDIF digital audio selectors, input circuit 0.

**CN17, CN23, CN25, CN55** → AES3 / SPDIF digital audio selectors, output circuit 0.

1-2: AES3 Digital Audio.

2-3: SPDIF Digital Audio.

**CN24, CN31, CN32, CN33, CN38** → AES3 / SPDIF digital audio selectors, input circuit 1.

**CN30, CN39, CN40, CN56** → AES3 / SPDIF digital audio selectors for output circuit 1.

1-2: AES3 Digital Audio.

2-3: SPDIF Digital Audio.

**CN14, CN15, CN19, CN21, CN26** → AES3 / SPDIF digital audio selectors, input circuit 2.

**CN20, CN27, CN29, CN57** → AES3 / SPDIF digital audio selectors, output circuit 2.

1-2: AES3 Digital Audio.

2-3: SPDIF Digital Audio.

**CN28, CN35, CN36, CN37, CN41** → AES3 / SPDIF digital audio selectors, input circuit 3.

**CN34, CN42, CN43, CN58** → AES3 / SPDIF digital audio selectors, output circuit 3.

1-2: AES3 Digital Audio.

2-3: SPDIF Digital Audio.

The default position of these PJs is 1-2; that is, they are configured to work with digital audio in AES/EBU format.

### Firmware modules.

At the firmware level, this board is made up of the following modules:

- **PIC microcontroller:** manages board communications and start-up.
- **FPGA programmable device:** manages SRCs and the TDM bus.

The firmware versions can be brought up to date by using the “**BC2000D Firmware Upgrade**” software application.

**IMPORTANT NOTE:** there is a specific firmware version for FPGA module when the BC 2000 D system is working as a switching matrix of 1024x1024 channels.

**Signal layout in the RJ 45 connectors of the board.**

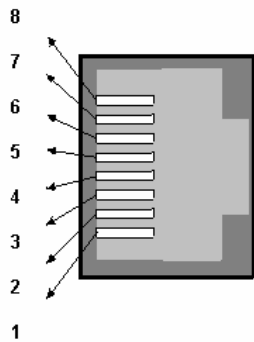

	'1' Inputs	'2' Outputs	'3' GPI	'4' GPO
8	IN 2 (1R) N	OUT 2 (1R) N	GND GPI2	GND GPO2
7	IN 2 (1R) P	OUT 2 (1R) P	GPI2	GPO2
6	IN 3 (2L) N	OUT 3 (2L) N	GND GPI3	GND GPO3
5	IN 4 (2R) N	OUT 4 (2R) N	GND GPI4	GND GPO4
4	IN 4 (2R) P	OUT 4 (2R) P	GPI4	GPO4
3	IN 3 (2L) P	OUT 3 (2L) P	GPI3	GPO3
2	IN 1 (1L) N	OUT 1 (1L) N	GND GPI1	GND GPO1
1	IN 1 (1L) P	OUT 1 (1L) P	GPI1	GPO1
Rack	GND	GND	GND	GND

**BC2202 technical specifications.**

Digital inputs:

- Isolated by transformer.
- SRC converters accept signal at 32, 44.1, 48 and 96 kHz and 16, 20 or 24 bits.

Digital outputs:

- Default digital signal format: 24 bits, 48 kHz. The outputs are equipped also with SRC converters that can deliver signal at 32, 44.1, 48 and 96 kHz (software configurable).

GPI inputs:

- Inputs protected by optocoupler (4N35).
- Maximum input current: 60 mA.
- A voltage ranging from 5 V to 30 V will be applied.

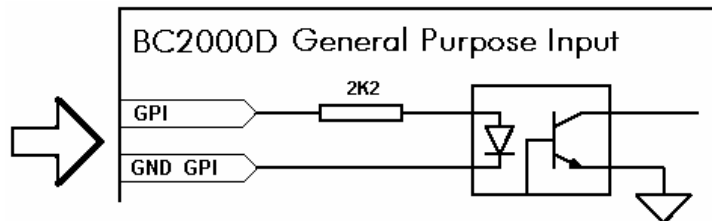

GPO outputs:

- Outputs protected by optocoupler (TLP371).
- Maximum current: 80 mA.
- Recommended maximum voltage: 200 V.
- Maximum power: 250 mW at 40° C.
- Requires external power supply.

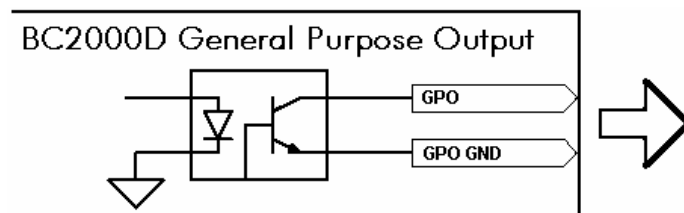

**General characteristics.**

- Approximate consumption: 4 watts.
- Approximate dimensions:  
Front: 17 x 172 mm.  
Depth: 255 mm.
- Approximate weight: 295 grams.

Characteristics are subject to change without notice.

## 2.4. BC2203MH. Analog MIC/LIN input and headphone output module.

### General description.

The BC2203MH board is capable of managing four TDM IN bus time-slots to insert four analog mono signals into the system with mic or line level, and can furnish 48 volts of PHANTOM power to the microphones that require it. It also manages four TDM OUT bus time-slots to extract two signals from the system for two stereo headphones.

This board is inserted into the rear part of the BC2000DF rack, where it occupies two slots.

### Panel description.

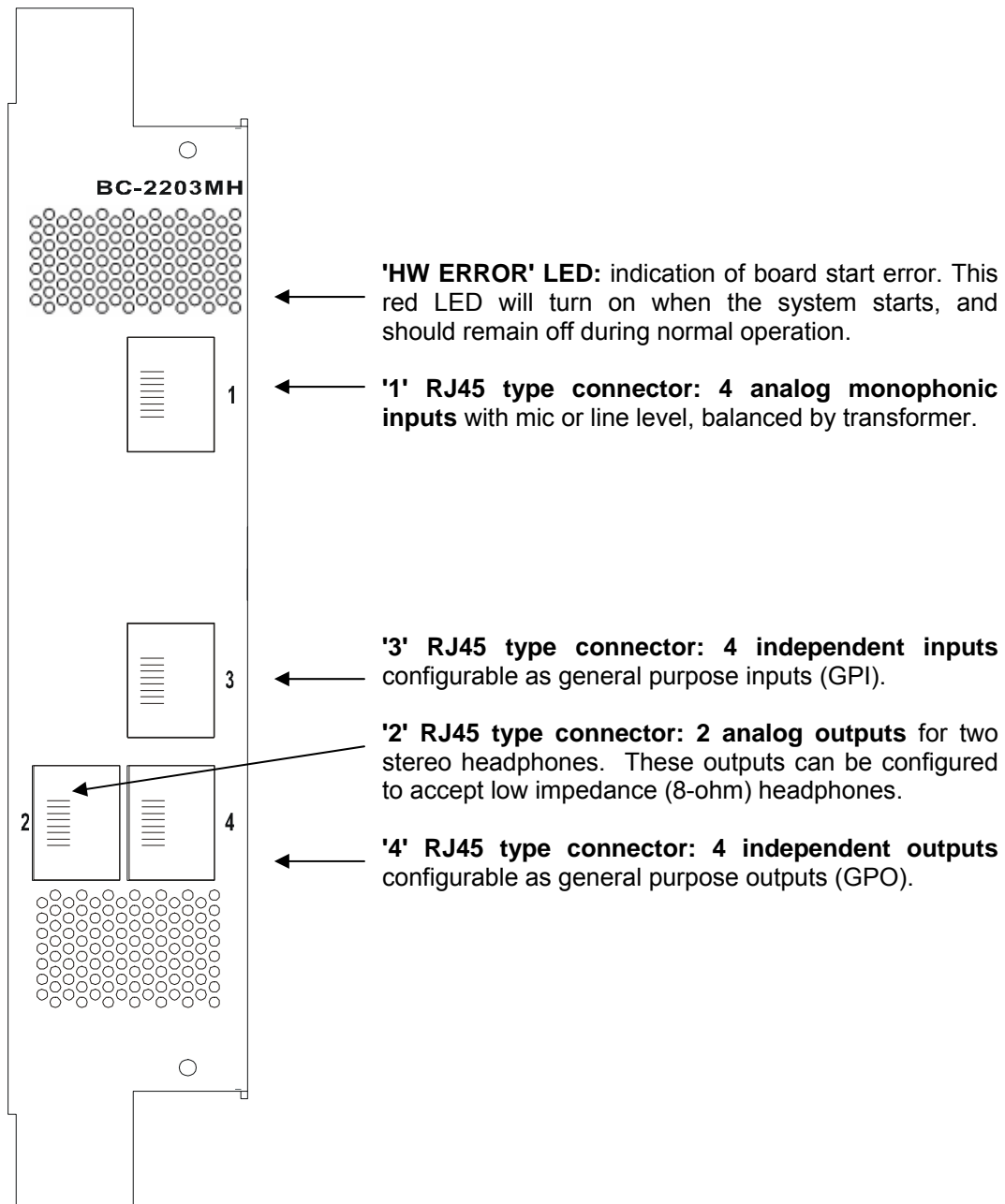

**Other characteristics and features.**

- Internal warning signal indicating a failure in one of the power supplies. If a failure occurs, the "ALARM" LED on the BC2240 controller board will light up.
- Power feed circuit designed to support hot-swapping operations.
- Digital adjustment of analog gain ( $\pm 12$  dB) in the 4 inputs.
- Digital adjustment of digital gain (-40/+24 dB) in the 4 inputs.

**Programming jumpers.**

This board has a series of internal programming jumpers (PJ). By default, this board is configured to work with high impedance headphones (higher than 150 $\Omega$ ). If you use low impedance headphones (below 150 $\Omega$ ), you will need to pull the board out and change the J1, J2, J3 and J4 jumpers on the board marked "472-001-311" to position 2-3.

**Firmware modules.**

At the firmware level, this board is made up of the following modules:

- **PIC microcontroller:** manages board communications and start-up.
- **FPGA programmable device:** manages the converters and the TDM bus.

The firmware versions can be brought up to date by using the "BC2000D Firmware Upgrade" software application.

**IMPORTANT NOTE:** there is a specific firmware version for FPGA module when the BC 2000 D system is working as a switching matrix of 1024x1024 channels.

**Signal layout in the RJ 45 connectors of the board.**

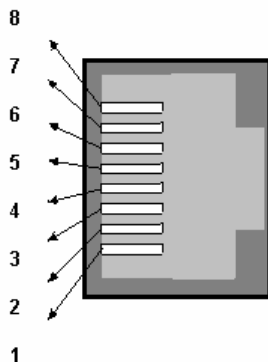

	'1' Inputs	'2' Outputs	'3' GPI	'4' GPO
8	IN 2 V-	OUT 1R V-	GND GPI2	GND GPO2
7	IN 2 V+	OUT 1R V+	GPI2	GPO2
6	IN 3 V-	OUT 2L V-	GND GPI3	GND GPO3
5	IN 4 V-	OUT 2R V-	GND GPI4	GND GPO4
4	IN 4 V+	OUT 2R V+	GPI4	GPO4
3	IN 3 V+	OUT 2L V+	GPI3	GPO3
2	IN 1 V-	OUT 1L V-	GND GPI1	GND GPO1
1	IN 1 V+	OUT 1L V+	GPI1	GPO1
Rack	AGND	AGND	AGND	AGND

**BC2203MH technical specifications.**

Analog inputs:

- 24-bit, 48 kHz A/D converters.
- PHANTOM power supply voltage: +48 V (software configurable).

Analog outputs:

- 24-bit, 48 kHz D/A converters.
- Capacity to feed high and low impedance headphones.

Bandwidth:

- Mic and line inputs: 40-20,000 Hz @ +/- 0.5 dB.  
20-20,000 Hz @ +/-1.5 dB.

Distortion:

- Mic and line inputs (nominal levels): < 0.1% @ 50-20,000 Hz.  
< 0.39% @ 20-20,000 Hz.

Noise:

- Microphone inputs: Equivalent noise: < -122 dBu @ G = +52 dB.
- Line inputs: Absolute noise: < -77 dBu.

Cross-talk:

- Between line inputs: < -74 dB @ 20-20,000 Hz.
- Line inputs on microphone inputs: < -38 dB @ 20-20,000 Hz.
- Between microphone inputs: < -78 dB @ 20-20,000 Hz.
- Between headsets:
  - 600 Ohm.: < -70 dB @ 20-20,000 Hz.
  - 10 Ohm.: < -50 dB @ 20-20,000 Hz.
- Headset outputs on microphone inputs:
  - 600 Ohm.: < -50 dB @ 20-20,000 Hz.
  - 10 Ohm.: < -34 dB @ 20-20,000 Hz.
- Headset outputs on line inputs:
  - 600 Ohm.: < -71 dB @ 20-20,000 Hz.
  - 10 Ohm.: < -74 dB @ 20-20,000 Hz.

Input range:

- Microphone inputs: -72 dBu ----- -27 dBu.
- Line inputs: -20 dBu ----- +22 dBu.

GPI inputs:

- Inputs protected by optocoupler (4N35).
- Maximum input current: 60 mA.
- A voltage ranging from 5 V to 30 V will be applied.

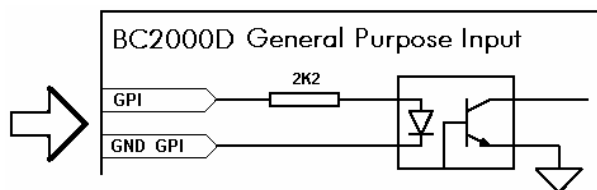

GPO outputs:

- Outputs protected by optocoupler (TLP371).
- Maximum current: 80 mA.
- Recommended maximum voltage: 200 V.
- Maximum power: 250 mW at 40° C.
- Requires external power supply.

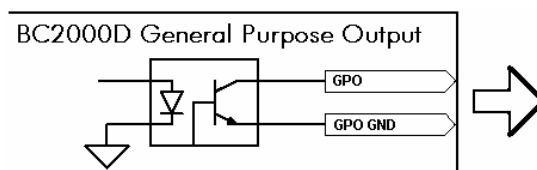

**General characteristics.**

- Approximate consumption: 7.5 watts.
- Approximate dimensions:
  - Front: 34 x 172 mm.
  - Depth: 255 mm.
- Approximate weight: 560 grams.

**Characteristics are subject to change without notice.**

## 2.5. BC2203M. Analog MIC/LIN input module.

### General description.

The BC2203M board is capable of managing four TDM IN bus time-slots to insert four analog mono signals into the system with mic or line level, and can furnish 48 volts of PHANTOM power to the microphones that require it.

This board is inserted into the rear part of the BC2000DF rack.

### Panel description.

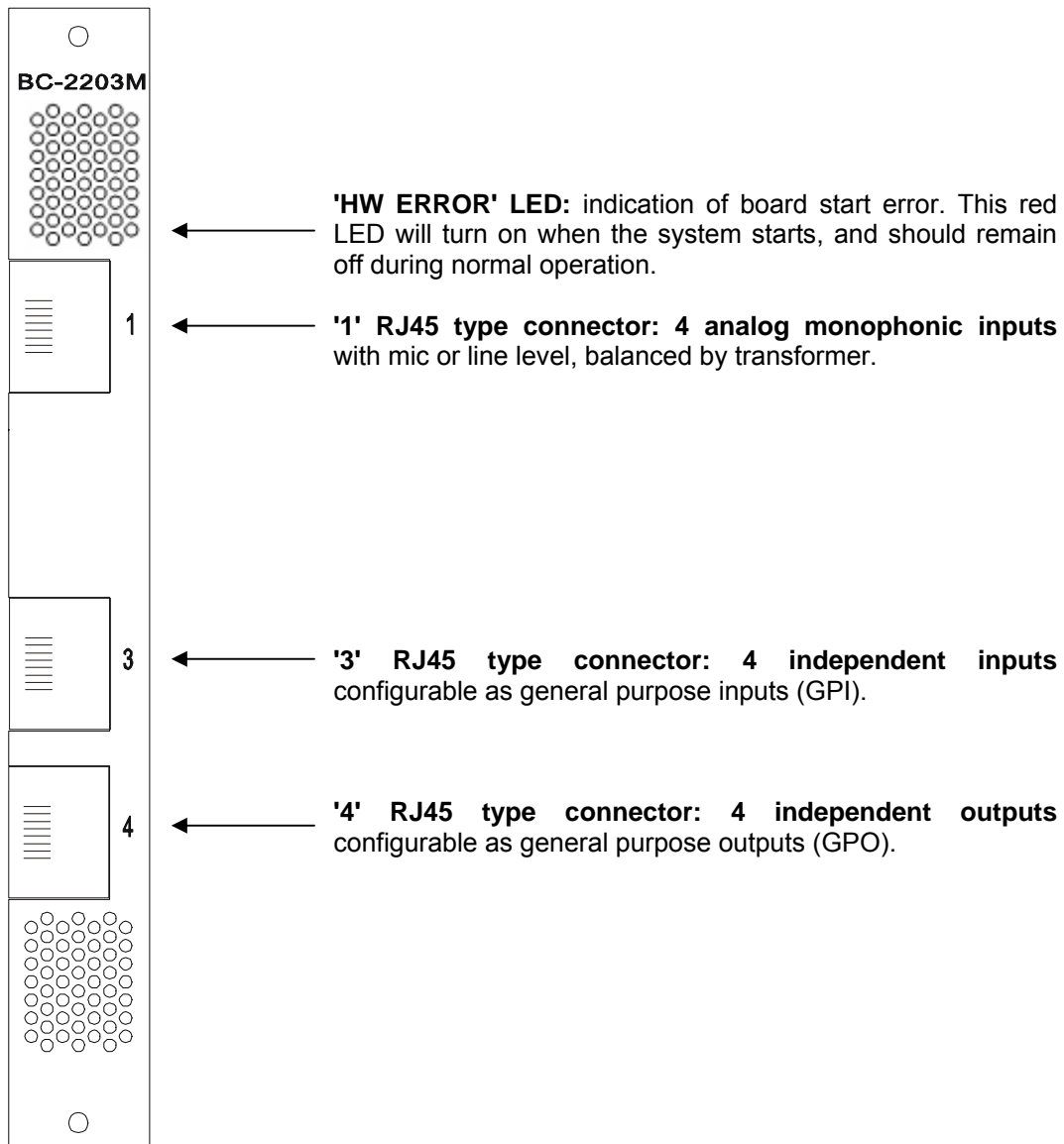



**Other characteristics and features.**

- Internal warning signal indicating a failure in one of the power supplies. If a failure occurs, the "ALARM" LED on the BC2240 controller board will light up.
- Power feed circuit designed to support hot-swapping operations.
- Digital adjustment of analog gain ( $\pm 12$  dB) in the 4 inputs.
- Digital adjustment of digital gain (-40/+24dB) in the 4 inputs.

**Programming jumpers.**

This board has a series of internal programming jumpers (PJ). However, these jumpers are configured at the factory and, in normal operation, do not need to be changed.

**Firmware modules.**

At the firmware level, this board is made up of the following modules:

- **PIC microcontroller:** manages board communications and start-up.
- **FPGA programmable device:** manages the converters and the TDM bus.

The firmware versions can be brought up to date by using the "BC2000D Firmware Upgrade" software application.

**IMPORTANT NOTE:** there is an specific firmware version for FPGA module when the BC 2000 D system is working as a switching matrix of 1024x1024 channels.

**Signal layout in the RJ 45 connectors of the board.**

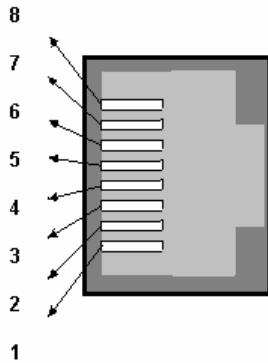

	'1' Inputs	-	'3' GPI	'4' GPO
8	IN 2 V-	-	GND GPI2	GND GPO2
7	IN 2 V+	-	GPI2	GPO2
6	IN 3 V-	-	GND GPI3	GND GPO3
5	IN 4 V-	-	GND GPI4	GND GPO4
4	IN 4 V+	-	GPI4	GPO4
3	IN 3 V+	-	GPI3	GPO3
2	IN 1 V-	-	GND GPI1	GND GPO1
1	IN 1 V+	-	GPI1	GPO1
Rack	AGND	-	AGND	AGND

**BC2203M technical specifications.**

See BC2203MH module specifications.

**General characteristics.**

- Approximate consumption: 6 watts.
- Approximate dimensions:  
Front: 17 x 172 mm.  
Depth: 255 mm.
- Approximate weight: 400 grams.

Characteristics are subject to change without notice.

## 2.6. BC2204. Analog line input module.

### General description.

The BC2204 board can manage four TDM IN bus time-slots to insert two analog stereo (or four mono) signals into the system with line level.

This board is inserted into the rear part of the BC2000DF rack.

### Panel description.

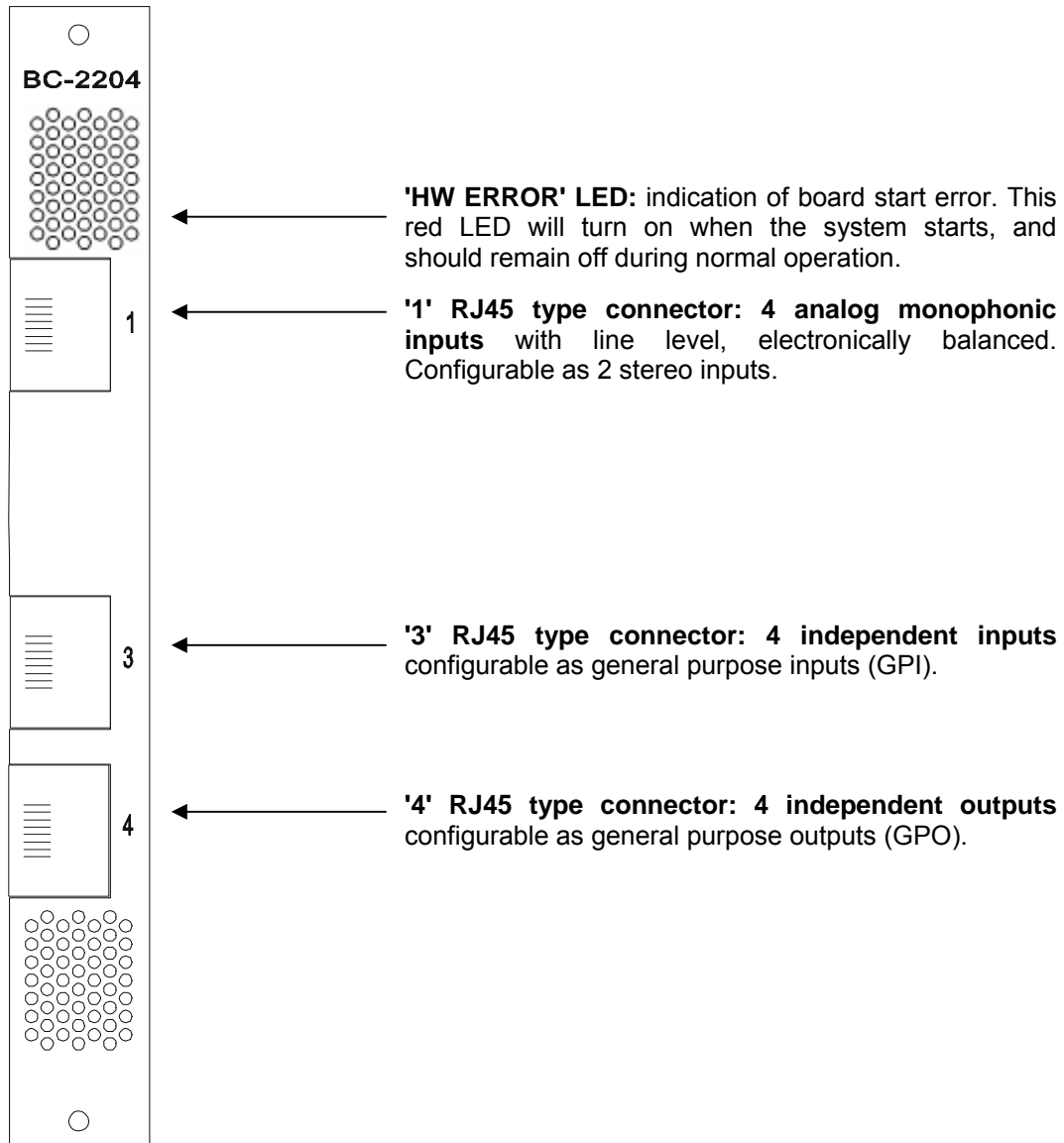

**Other characteristics and features.**

- Internal warning signal indicating a failure in one of the power supplies. If a failure occurs, the “ALARM” LED on the BC2240 controller board will light up.
- Power feed circuit designed to support hot-swapping operations.
- Digital adjustment of analog gain ( $\pm 12$  dB) in the 4 inputs.
- Digital adjustment of digital gain ( $\pm 12$  dB) in the 4 inputs.

**Programming jumpers.**

This board has a series of internal programming jumpers (PJ). However, these jumpers are configured at the factory and, in normal operation, do not need to be changed.

**Firmware modules.**

At the firmware level, this board is made up of the following modules:

- **PIC microcontroller:** manages board communications and start-up.
- **FPGA programmable device:** manages the converters and the TDM bus.

The firmware versions can be brought up to date by using the “**BC2000D Firmware Upgrade**” software application.

**IMPORTANT NOTE:** there is an specific firmware version for FPGA module when the BC 2000 D system is working as a switching matrix of 1024x1024 channels.

**Signal layout in the RJ 45 connectors of the board.**

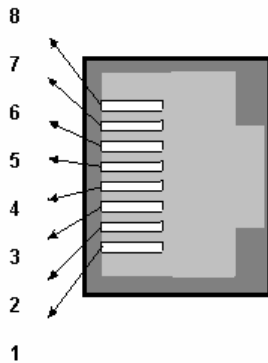

	'1' Inputs	-	'3' GPI	'4' GPO
8	IN 2 (1R) V-	-	GND GPI2	GND GPO2
7	IN 2 (1R) V+	-	GPI2	GPO2
6	IN 3 (2L) V-	-	GND GPI3	GND GPO3
5	IN 4 (2R) V-	-	GND GPI4	GND GPO4
4	IN 4 (2R) V+	-	GPI4	GPO4
3	IN 3 (2L) V+	-	GPI3	GPO3
2	IN 1 (1L) V-	-	GND GPI1	GND GPO1
1	IN 1 (1L) V+	-	GPI1	GPO1
Rack	AGND	-	AGND	AGND

**BC2204 technical specifications.**

This board has the same specifications as the BC2201 board, except for the characteristics relative to the analog outputs that are not implemented.

**General characteristics.**

- Approximate consumption: 9 watts.
- Approximate dimensions:  
  - Front: 17 x 172 mm.
  - Depth: 255 mm.
- Approximate weight: 295 grams.

Characteristics are subject to change without notice.

## 2.7. BC2205. Analog line output module.

### General description.

The BC2205 board can manage four TDM OUT bus time-slots to extract two analog stereo (or four mono) signals from the system with line level.

This board is inserted into the rear part of the BC2000DF rack.

### Panel description.

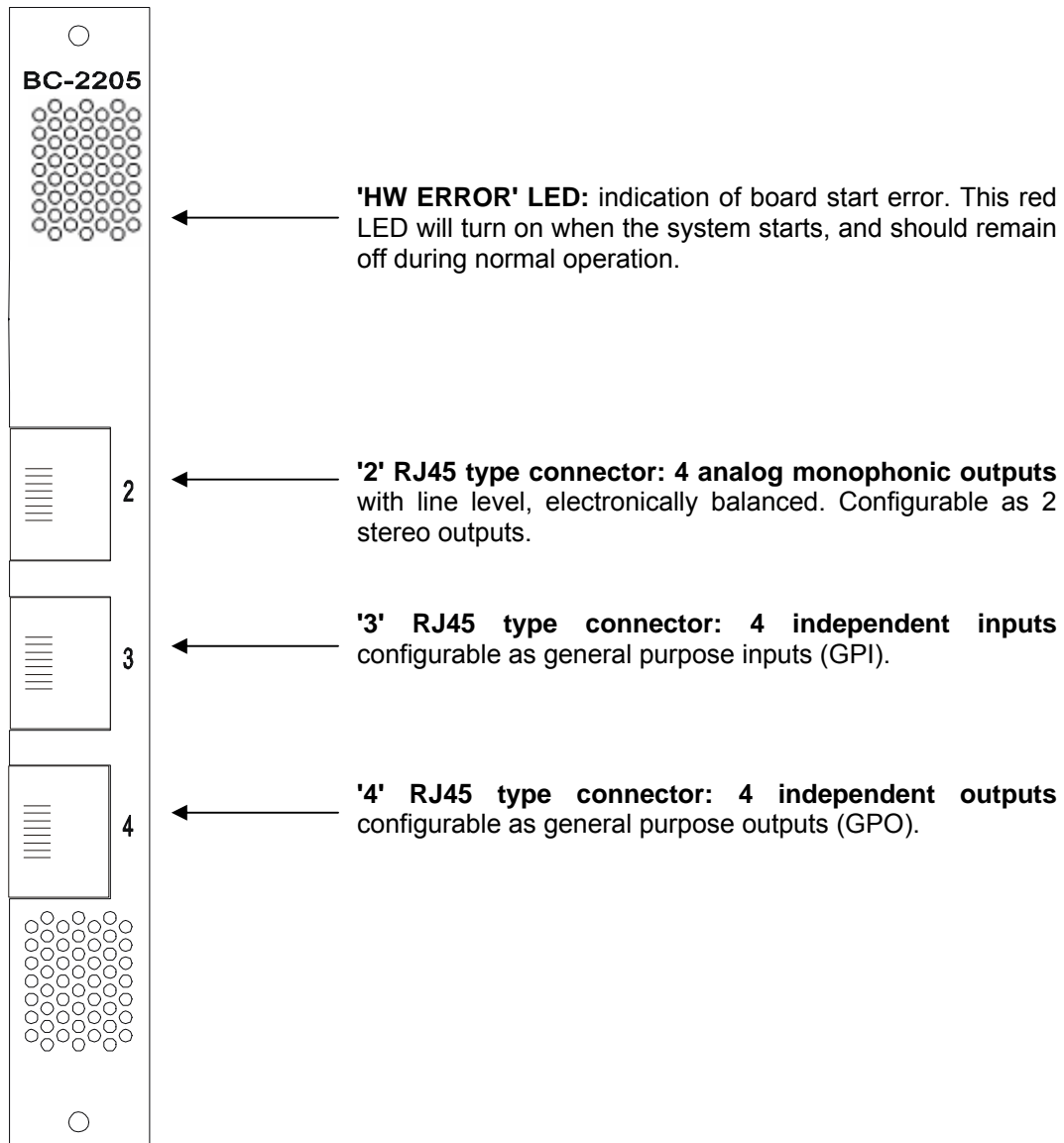

**Other characteristics and features.**

- Internal warning signal indicating a failure in one of the power supplies. If a failure occurs, the “ALARM” LED on the BC2240 controller board will light up.
- Power feed circuit designed to support hot-swapping operations.
- Digital adjustment of analog gain ( $\pm 12$  dB) in the 4 outputs.
- Digital adjustment of digital gain ( $\pm 12$  dB) in the 4 outputs.

**Programming jumpers.**

This board has a series of internal programming jumpers (PJ). However, these jumpers are configured at the factory and, in normal operation, do not need to be changed.

**Firmware modules.**

At the firmware level, this board is made up of the following modules:

- **PIC microcontroller:** manages board communications and start-up.
- **FPGA programmable device:** manages the converters and the TDM bus.

The firmware versions can be brought up to date by using the “**BC2000D Firmware Upgrade**” software application.

**IMPORTANT NOTE:** there is an specific firmware version for FPGA module when the BC 2000 D system is working as a switching matrix of 1024x1024 channels.

**Signal layout in the RJ 45 connectors of the board.**

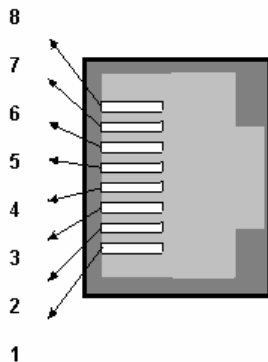

	-	'2' Outputs	'3' GPI	'4' GPO
8	-	OUT 2 (1R) V-	GND GPI2	GND GPO2
7	-	OUT 2 (1R) V+	GPI2	GPO2
6	-	OUT 3 (2L) V-	GND GPI3	GND GPO3
5	-	OUT 4 (2R) V-	GND GPI4	GND GPO4
4	-	OUT 4 (2R) V+	GPI4	GPO4
3	-	OUT 3 (2L) V+	GPI3	GPO3
2	-	OUT 1 (1L) V-	GND GPI1	GND GPO1
1	-	OUT 1 (1L) V+	GPI1	GPO1
Rack	-	AGND	AGND	AGND

**BC2205 technical specifications.**

This board has the same specifications as the BC2201, except for the characteristics relative to the analog inputs that are not implemented.

**General characteristics.**

- Approximate consumption: 9 watts.
- Approximate dimensions:  
  - Front: 17 x 172 mm.
  - Depth: 255 mm.
- Approximate weight: 300 grams.

**Characteristics are subject to change without notice.**

## 2.8. BC2206. AES/EBU digital input module.

### General description.

The BC2206 board can manage eight TDM IN bus time-slots to insert four AES3 (or SPDIF) digital stereo signals into the system.

This board is inserted into the rear part of the BC2000DF rack.

### Panel description.

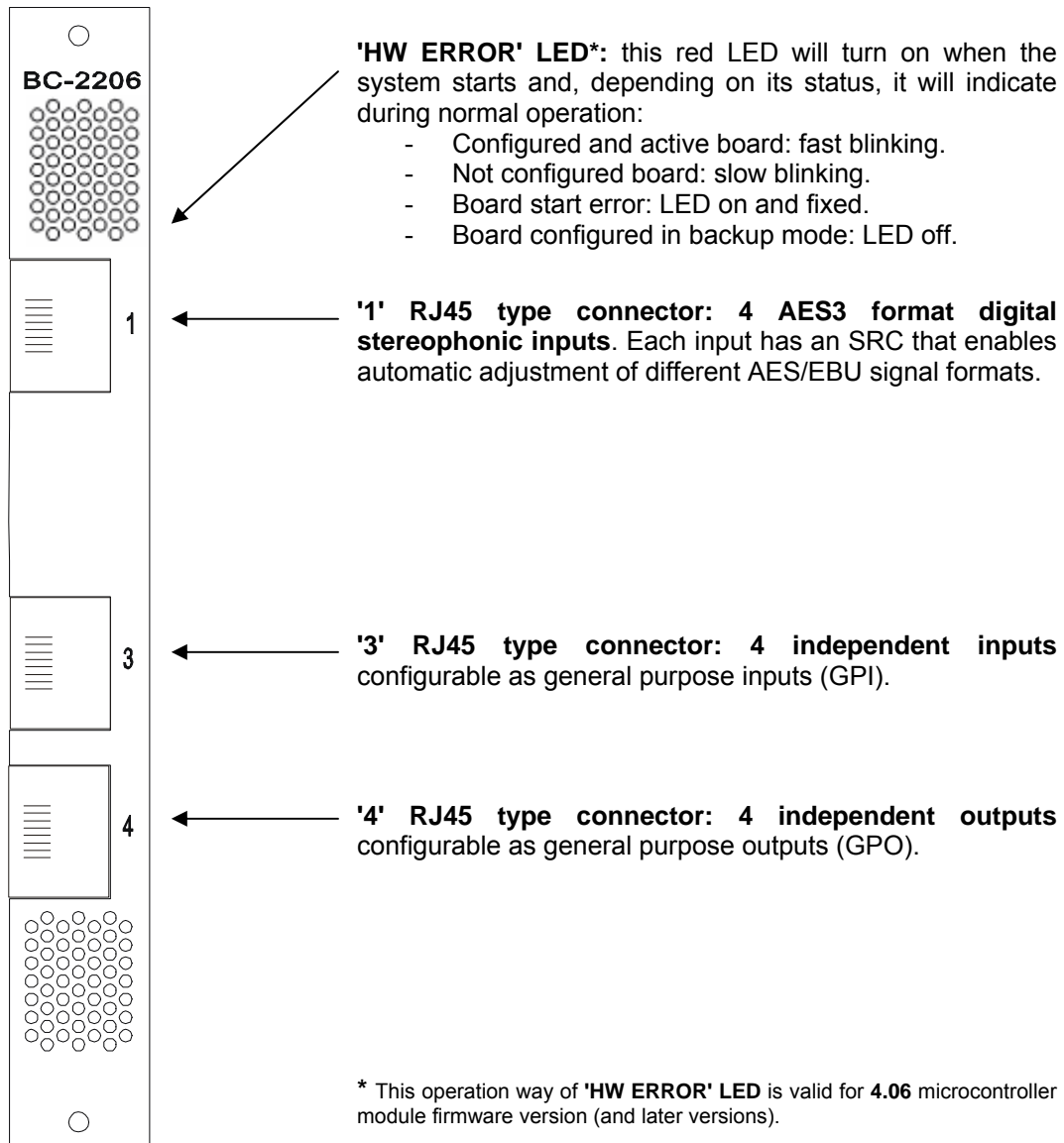

**Other characteristics and features.**

- Internal warning signal indicating a failure in one of the power supplies. If a failure occurs, the “ALARM” LED on the BC2240 controller board will light up.
- Power feed circuit designed to support hot-swapping operations.
- Digital adjustment of digital gain ( $\pm 12$  dB) in the 4 inputs.
- Possibility of converting the module so that it can use SPDIF signals by manipulating the internal programming jumpers.

**Programming jumpers.**

This board is equipped with a series of internal programming jumpers (PJ) that allow you to change the format of the digital signal to be used between AES3 and SPDIF. You can independently change the format of each one of the four audio channels (circuit 0, 1, 2 and 3) by changing the following PJs:

- CN12, CN13, CN16, CN18, CN22** → AES3 / SPDIF digital audio selectors, input circuit 0.  
 1-2: AES3 Digital Audio.  
 2-3: SPDIF Digital Audio.
- CN24, CN31, CN32, CN33, CN38** → AES3 / SPDIF digital audio selectors, input circuit 1.  
 1-2: AES3 Digital Audio.  
 2-3: SPDIF Digital Audio.
- CN14, CN15, CN19, CN21, CN26** → AES3 / SPDIF digital audio selectors, input circuit 2.  
 1-2: AES3 Digital Audio.  
 2-3: SPDIF Digital Audio.
- CN28, CN35, CN36, CN37, CN41** → AES3 / SPDIF digital audio selectors, input circuit 3.  
 1-2: AES3 Digital Audio.  
 2-3: SPDIF Digital Audio.

The default position of these PJs is 1-2; that is, they are configured to work with digital audio in AES/EBU format.

**Firmware modules.**

At the firmware level, this board is made up of the following modules:

- **PIC microcontroller:** manages board communications and start-up.
- **FPGA programmable device:** manages SRCs and the TDM bus.

The firmware versions can be brought up to date by using the “**BC2000D Firmware Upgrade**” software application.

**IMPORTANT NOTE:** there is an specific firmware version for FPGA module when the BC 2000 D system is working as a switching matrix of 1024x1024 channels.

**Signal layout in the RJ 45 connectors of the board.**

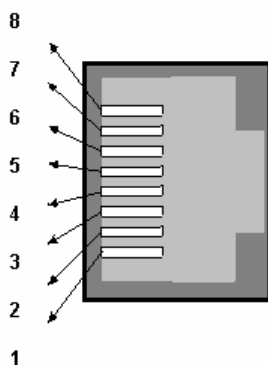

	'1' Inputs	-	'3' GPI	'4' GPO
8	IN 2 (1R) N	-	GND GPI2	GND GPO2
7	IN 2 (1R) P	-	GPI2	GPO2
6	IN 3 (2L) N	-	GND GPI3	GND GPO3
5	IN 4 (2R) N	-	GND GPI4	GND GPO4
4	IN 4 (2R) P	-	GPI4	GPO4
3	IN 3 (2L) P	-	GPI3	GPO3
2	IN 1 (1L) N	-	GND GPI1	GND GPO1
1	IN 1 (1L) P	-	GPI1	GPO1
Rack	GND	-	GND	GND

**BC2206 technical specifications.**

This board has the same specifications as the BC2202 board, except for the characteristics relative to the digital outputs.

**General characteristics.**

- Approximate consumption: 4 watts.
- Approximate dimensions:
  - Front: 17 x 172 mm.
  - Depth: 255 mm.
- Approximate weight: 280 grams.

**Characteristics are subject to change without notice.**



## 2.9. BC2207. AES/EBU digital output module.

### General description.

The BC2207 board can manage eight TDM OUT bus time-slots to extract four AES3 (or SPDIF) digital stereo signals from the system.

This board is inserted into the rear part of the BC2000DF rack.

### Panel description.

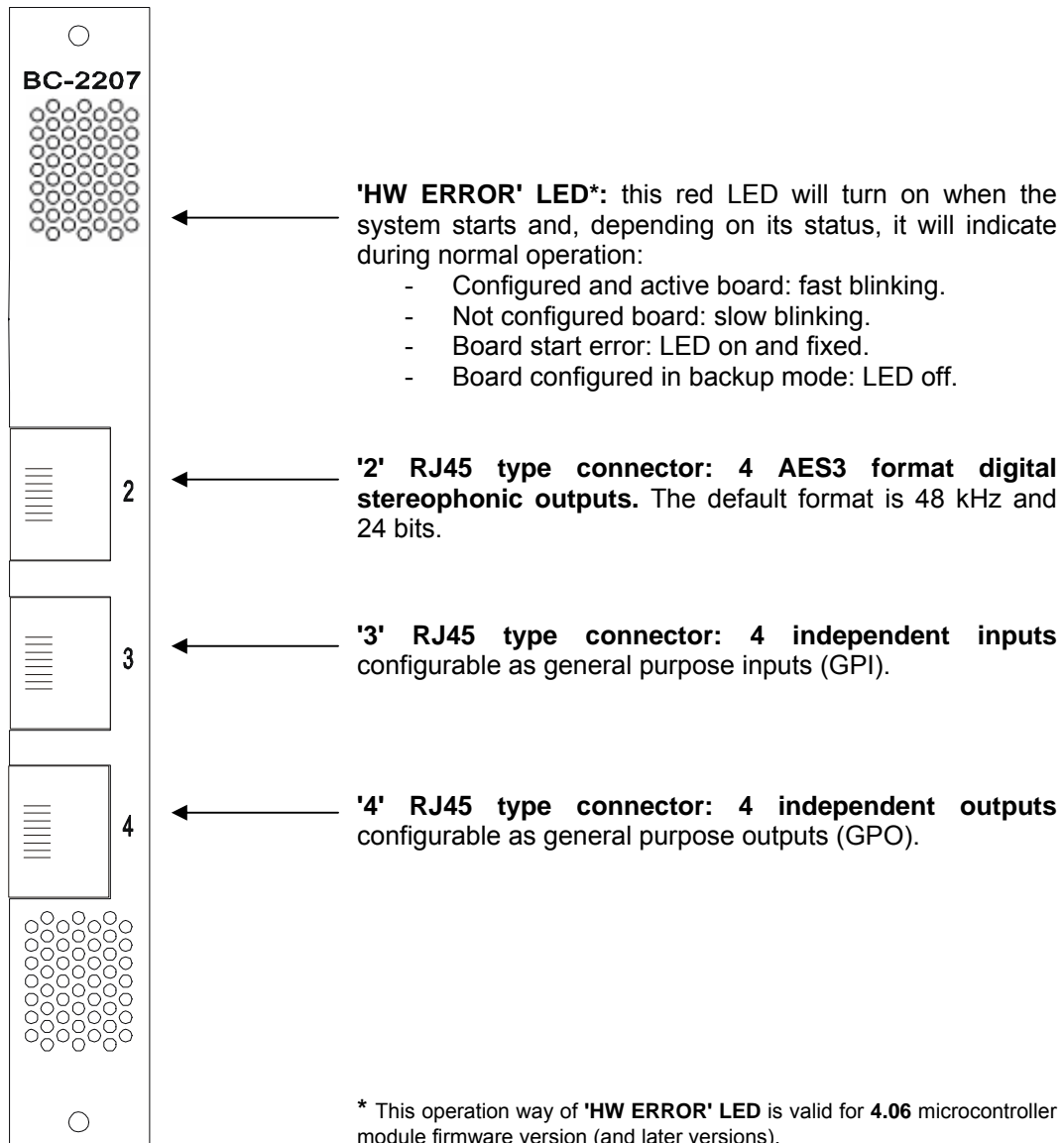

**Other characteristics and features.**

- Internal warning signal indicating a failure in one of the power supplies. If a failure occurs, the “ALARM” LED on the BC2240 controller board will light up.
- Power feed circuit designed to support hot-swapping operations.
- Digital adjustment of digital gain ( $\pm 12$  dB) in the 4 outputs.
- Possibility of converting the module so that it can use SPDIF signals by manipulating the internal programming jumpers.

**Programming jumpers.**

This board is equipped with a series of internal programming jumpers (PJ) that allow you to change the format of the digital signal to be used between AES3 and SPDIF. You can independently change the format of each one of the four audio channels (circuit 0, 1, 2 and 3) by changing the following PJs:

**CN17, CN23, CN25, CN55** → AES3 / SPDIF digital audio selectors for output circuit 0.

1-2: AES3 Digital Audio.

2-3: SPDIF Digital Audio.

**CN30, CN39, CN40, CN56** → AES3 / SPDIF digital audio selectors for output circuit 1.

1-2: AES3 Digital Audio.

2-3: SPDIF Digital Audio.

**CN20, CN27, CN29, CN57** → AES3 / SPDIF digital audio selectors for output circuit 2.

1-2: AES3 Digital Audio.

2-3: SPDIF Digital Audio.

**CN34, CN42, CN43, CN58** → AES3 / SPDIF digital audio selectors for output circuit 3.

1-2: AES3 Digital Audio.

2-3: SPDIF Digital Audio.

The default position of these PJs is 1-2; that is, they are configured to work with digital audio in AES/EBU format.

**Firmware modules.**

At the firmware level, this board is made up of the following modules:

- **PIC microcontroller:** manages board communications and start-up.
- **FPGA programmable device:** manages SRCs and the TDM bus.

The firmware versions can be brought up to date by using the “**BC2000D Firmware Upgrade**” software application.

**IMPORTANT NOTE:** there is an specific firmware version for FPGA module when the BC 2000 D system is working as a switching matrix of 1024x1024 channels.

**Signal layout in the RJ 45 connectors of the board.**

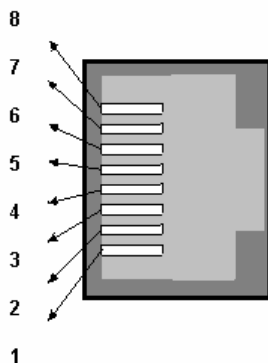

	-	'2' Outputs	'3' GPI	'4' GPO
8	-	OUT 2 (1R) N	GND GPI2	GND GPO2
7	-	OUT 2 (1R) P	GPI2	GPO2
6	-	OUT 3 (2L) N	GND GPI3	GND GPO3
5	-	OUT 4 (2R) N	GND GPI4	GND GPO4
4	-	OUT 4 (2R) P	GPI4	GPO4
3	-	OUT 3 (2L) P	GPI3	GPO3
2	-	OUT 1 (1L) N	GND GPI1	GND GPO1
1	-	OUT 1 (1L) P	GPI1	GPO1
Rack	-	GND	GND	GND

**BC2207 technical specifications.**

This board has the same specifications as the BC2202 board, except for the characteristics relative to the digital inputs.

**General characteristics.**

- Approximate consumption: 4 watts.
- Approximate dimensions:
  - Front: 17 x 172 mm.
  - Depth: 255 mm.
- Approximate weight: 280 grams.

**Characteristics are subject to change without notice.**

## 2.10. BC2208. Analog line input/output module with transformer balanced inputs.

### General description.

The BC2208 board can manage four TDM IN bus time-slots to insert two analog stereo (or four mono) signals into the system with line level, and four TDM OUT bus time-slots to extract two analog stereo (or four mono) signals from the system with line level. The inputs are transformer balanced.

This board is inserted into the rear part of the BC2000DF rack.

### Panel description.

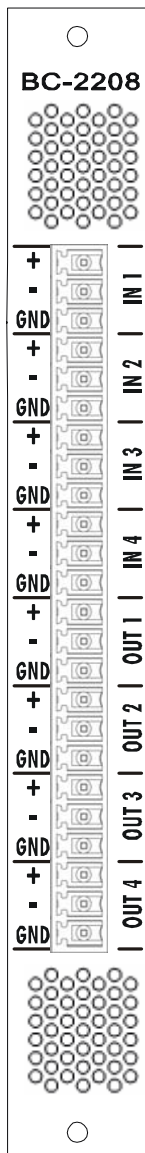

**'HW ERROR' LED:** this red LED will turn on when the system starts and, depending on its status, it will indicate during normal operation:

- Configured and active board: fast blinking.
- Not configured board: slow blinking.
- Board start error: LED on and fixed.
- Board configured in backup mode: LED off.

**Multipin connectors: 4 analog monophonic inputs** with line level, transformer balanced. Configurable as 2 stereo inputs.

**Multipin connectors: 4 analog monophonic outputs** with line level, electronically balanced. Configurable as 2 stereo outputs.

### **Other characteristics and features.**

- Internal warning signal indicating a failure in one of the power supplies. If a failure occurs, the “ALARM” LED on the BC2240 controller board will light up.
- Power feed circuit designed to support hot-swapping operations.
- Digital adjustment of digital gain ( $\pm 12$  dB) in the 4 inputs and the 4 outputs.

### **Programming jumpers.**

This board has a series of internal programming jumpers (PJ). However, these jumpers are configured at the factory and, in normal operation, do not need to be changed.

### **Firmware modules.**

At the firmware level, this board is made up of the following modules:

- **PIC microcontroller:** manages board communications and start-up.
- **FPGA programmable device:** manages the converters and the TDM bus.

The firmware versions can be brought up to date by using the “**BC2000D Firmware Upgrade**” software application.

**IMPORTANT NOTE:** there is an specific firmware version for FPGA module when the BC 2000 D system is working as a switching matrix of 1024x1024 channels.

### **BC2208 technical specifications.**

#### Analog inputs:

- 24-bit, 48 kHz A/D converters.
- Nominal input level: +4 dBu (software configurable).
- Maximum input level: +22 dBu.
- Minimum input level: -8 dBu.

#### Analog outputs:

- 24-bit, 48 kHz D/A converters.
- Nominal output level: +4 dBu.
- Maximum output level: +22 dBu.

#### General audio specifications:

- Bandwidth: 20 to 20,000Hz  $\pm 0.5$  dB.
- Distortion: less than 0.08% between 40 and 20000Hz (less than 0.2% in the bandwidth).
- Input + output noise level (in audio frequencies): -85 dBu.
- Cross-talk: less than -100dB in the bandwidth.

### **General characteristics.**

- Approximate consumption: 6 watts.
- Approximate dimensions:
  - Front: 17 x 172 mm.
  - Depth: 255 mm.
- Approximate weight: 342 grams.

**Characteristics are subject to change without notice.**

## 2.11. BC2209. 8 Analog line input/output module.

### General description.

The BC2209 board can manage eight TDM IN bus time-slots to insert four analog stereo (or eight mono) signals into the system with line level, and eight TDM OUT bus time-slots to extract four analog stereo (or eight mono) signals from the system with line level.

This board is inserted into the rear part of the BC2000DF rack.

### Panel description.

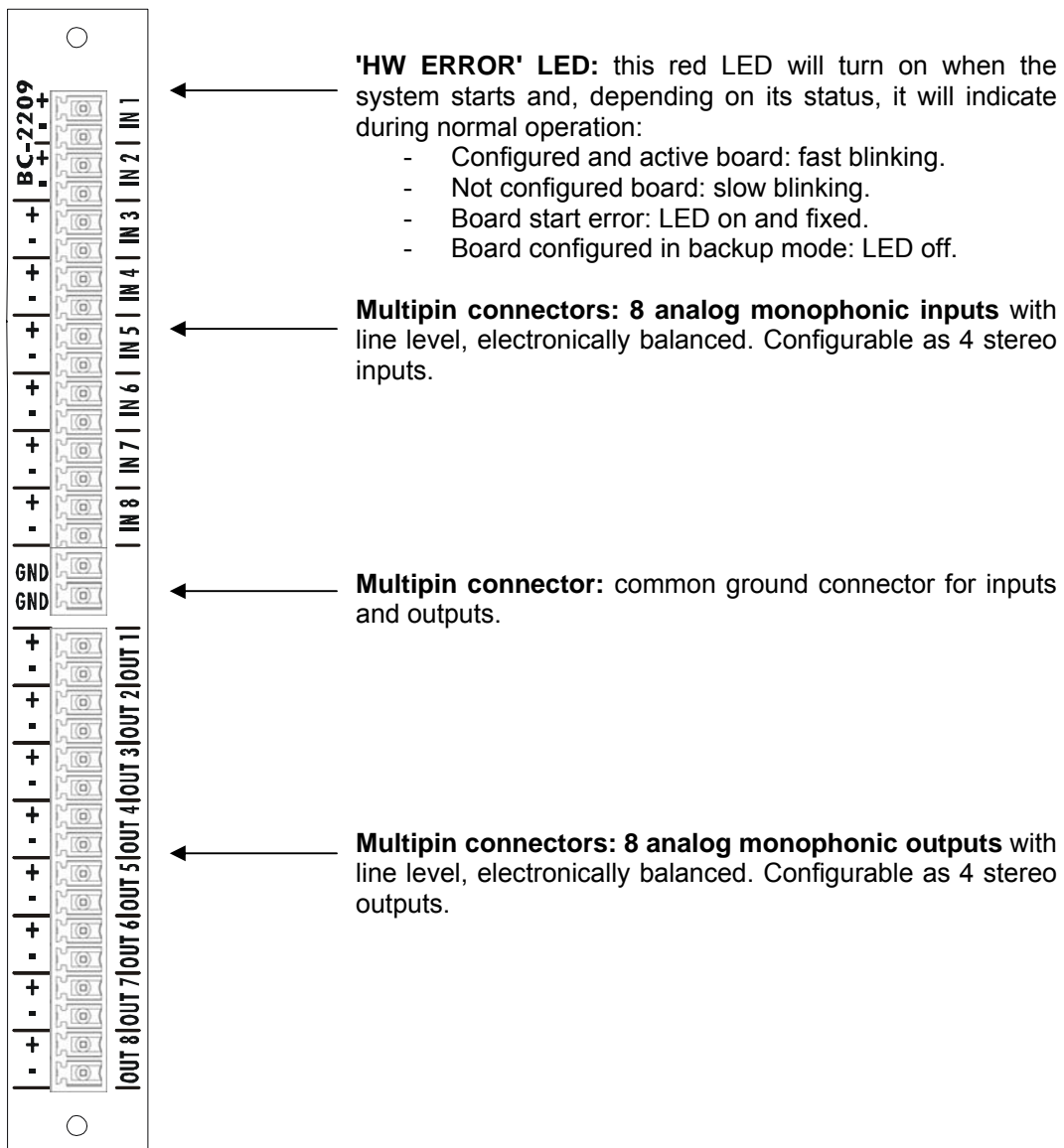

### **Other characteristics and features.**

- Internal warning signal indicating a failure in one of the power supplies. If a failure occurs, the “ALARM” LED on the BC2240 controller board will light up.
- Power feed circuit designed to support hot-swapping operations.
- Digital adjustment of digital gain ( $\pm 12$  dB) in the 8 inputs and the 8 outputs.

### **Programming jumpers.**

This board has a series of internal programming jumpers (PJ). However, these jumpers are configured at the factory and, in normal operation, do not need to be changed.

### **Firmware modules.**

At the firmware level, this board is made up of the following modules:

- **PIC microcontroller:** manages board communications and start-up.
- **FPGA programmable device:** manages the converters and the TDM bus.

The firmware versions can be brought up to date by using the “**BC2000D Firmware Upgrade**” software application.

**IMPORTANT NOTE:** there is an specific firmware version for FPGA module when the BC 2000 D system is working as a switching matrix of 1024x1024 channels.

### **BC2209 technical specifications.**

#### Analog inputs:

- 24-bit, 48 kHz A/D converters.
- Nominal input level: +4 dBu (software configurable).
- Maximum input level: +22 dBu.
- Minimum input level: -8 dBu.

#### Analog outputs:

- 24-bit, 48 kHz D/A converters.
- Nominal output level: +4 dBu.
- Maximum output level: +22 dBu.

#### General audio specifications:

- Bandwidth: 20 to 20,000Hz  $\pm 0.5$  dB.
- Distortion: less than 0.03% in the bandwidth.
- Input + output noise level (in audio frequencies): -84 dBu.
- Cross-talk: less than -90 dB in the bandwidth.

### **General characteristics.**

- Approximate consumption: 8 watts.
- Approximate dimensions:
  - Front: 17 x 172 mm.
  - Depth: 255 mm.
- Approximate weight: 299 grams.

**Characteristics are subject to change without notice.**

## 2.12. BC2211. AES 10 MADI module for linking racks.

### General description.

The BC2211 board manages 56 or 64 TDM bus time-slots to send and/or receive them through a 125-Mbps MADI multichannel digital audio link using coaxial or optical fiber cable. This board allows you to interconnect two BC 2000 D racks, or to connect any other MADI equipment item. It is compliant with the AES-10 standard.

You can install two modules with the same link for redundancy purposes.

This board is inserted into the rear part of the BC2000DF rack.

### Panel description.

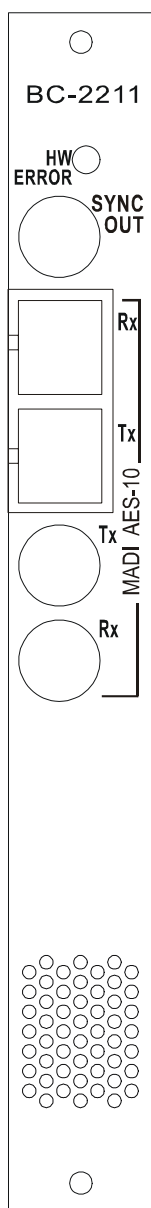

**'HW ERROR' LED\***: this red LED will turn on when the system starts and, depending on its status, it will indicate during normal operation:

- Configured and active board: fast blinking.
- Not configured board: slow blinking.
- Board start error: LED on and fixed.
- Board configured in backup mode: LED off.

**1.6-5.6 'SYNC OUT' female coaxial connector**: word-clock synchronism output with TTL level.

**SC 'Rx' and 'Tx' connectors**: FDDI PMD optical fiber interface with a range of 2000 meters (if your installation entails a range greater than 2000 meters, contact our sales department).

**1.6-5.6 female 'Rx' and 'Tx' coaxial connectors**: 75-ohm coaxial cable interface with a range of 50 meters.

\* This operation way of **'HW ERROR' LED** is valid for **1.42** microcontroller module firmware version (and later versions).



### **Other characteristics and features.**

- Internal warning signal indicating a failure in one of the power supplies. If a failure occurs, the "ALARM" LED on the BC2240 controller board will light up.
- Power feed circuit designed to support hot-swapping operations.

### **Programming jumpers.**

This board has a series of internal programming jumpers (PJ). However, these jumpers are configured at the factory and, in normal operation, do not need to be changed.

### **Firmware modules.**

At the firmware level, this board is made up of the following modules:

- **PIC microcontroller:** manages board communications and start-up.
- **FPGA programmable device:** manages the TDM bus.

The firmware versions can be brought up to date by using the "BC2000D Firmware Upgrade" software application.

**IMPORTANT NOTE:** there is a specific firmware version for FPGA module when the BC 2000 D system is working as a switching matrix of 1024x1024 channels.

### **BC2211 technical specifications.**

#### Synchronism output:

- Type: TTL (Word-Clock).
- Connector: 1.6-5.6 female coaxial.

#### Coaxial interface:

- Type: 75Ω coaxial.
- Nominal range: 50 m.
- Connectors: 1.6-5.6 female.
- Type of cable: 75 Ω ±2 Ω coaxial, attenuation less than 0.1 dB/m.

#### Optical fiber interface:

- Type: FDDI PMD.
- Nominal range: 2,000 meters (if your installation entails a range greater than 2000 meters, contact our sales department).
- Type of fiber: 62.5 / 125 μm MULTIMODE.
- Transmission: LED, 1300 nm.

### **General characteristics.**

- Approximate consumption: 8.5 watts.
- Approximate dimensions:
  - Front: 17 x 172 mm.
  - Depth: 255 mm.
- Approximate weight: 310 grams.

Characteristics are subject to change without notice.

## 2.13. BC2212. Dual AES 10 MADI module for linking racks.

### General description.

The BC2212 board has twice the capacity of the BC 2211 board. The BC 2212 manages up to 128 TDM bus time-slots to send and/or receive them through two 125-Mbps MADI multichannel digital audio links using coaxial or optical fiber cable. These two MADI links are independent. This board allows you to interconnect up to three BC 2000 D racks (you can use each of the two MADI links to connect to other 2 BC2211 or BC2212 boards placed in different racks), or to connect any other MADI equipment item. It is compliant with the AES-10 standard.

You can install two modules with the same link for redundancy purposes or you can use both links of the board redundantly (link 2 acts as a backup for link 1).

This board is inserted into the rear part of the BC2000DF rack.

### Panel description.

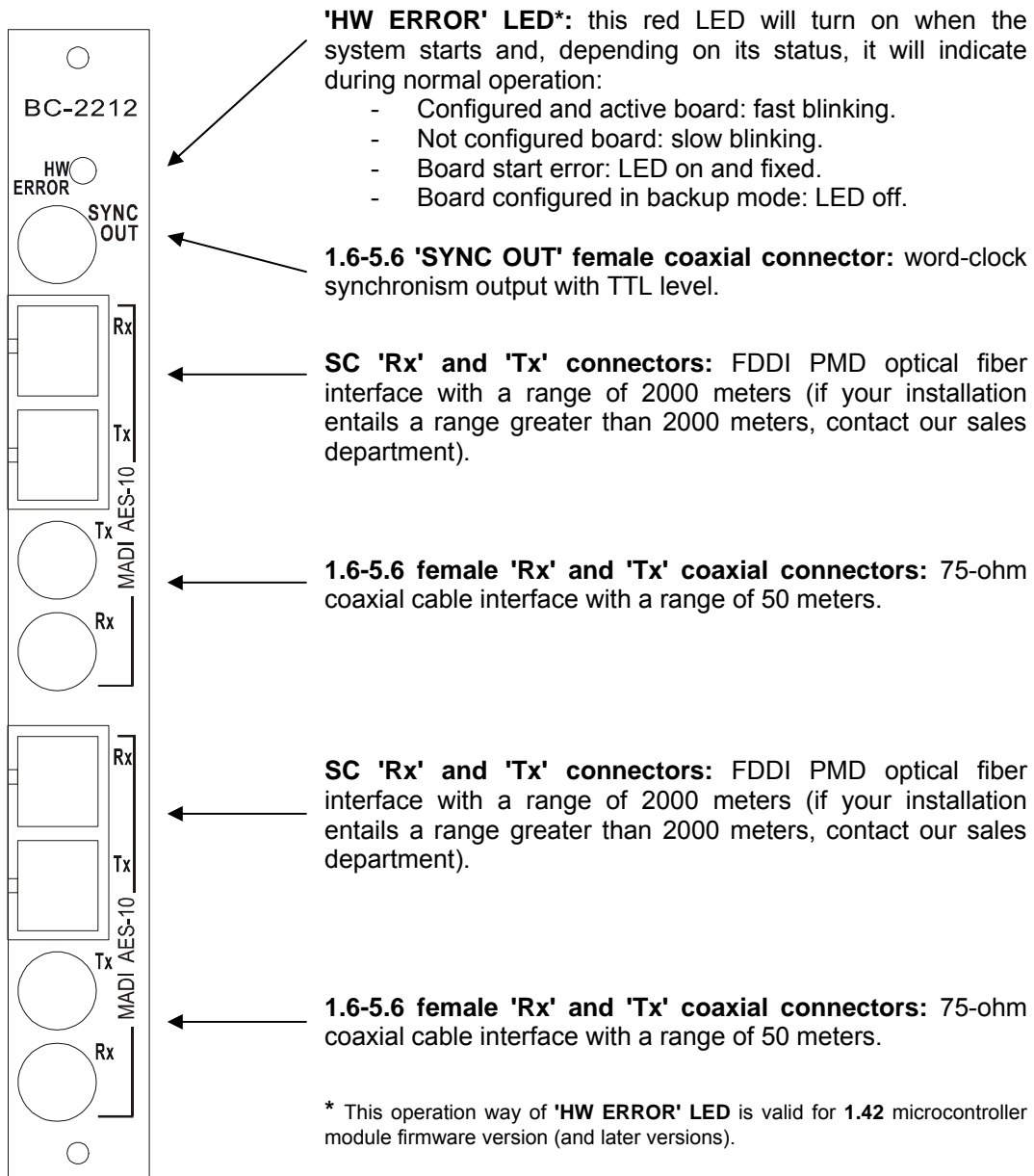

### **Other characteristics and features.**

- Internal warning signal indicating a failure in one of the power supplies. If a failure occurs, the "ALARM" LED on the BC2240 controller board will light up.
- Power feed circuit designed to support hot-swapping operations.

### **Programming jumpers.**

This board has a series of internal programming jumpers (PJ). However, these jumpers are configured at the factory and, in normal operation, do not need to be changed.

### **Firmware modules.**

At the firmware level, this board is made up of the following modules:

- **PIC microcontroller:** manages board communications and start-up.
- **FPGA programmable device:** manages the TDM bus.

The firmware versions can be brought up to date by using the "BC2000D Firmware Upgrade" software application.

**IMPORTANT NOTE:** there is a specific firmware version for FPGA module when the BC 2000 D system is working as a switching matrix of 1024x1024 channels.

### **BC2212 technical specifications.**

#### Synchronism output:

- Type: TTL (Word-Clock).
- Connector: 1.6-5.6 female coaxial.

#### Coaxial interface:

- Type: 75Ω coaxial.
- Nominal range: 50 m.
- Connectors: 1.6-5.6 female.
- Type of cable: 75Ω ±2Ω coaxial, attenuation less than 0.1 dB/m.

#### Optical fiber interface:

- Type: FDDI PMD.
- Nominal range: 2,000 meters (if your installation entails a range greater than 2000 meters, contact our sales department).
- Type of fiber: 62.5 / 125 μm MULTIMODE.
- Transmission: LED, 1300 nm.

### **General characteristics.**

- Approximate consumption: 10.5 watts.
- Approximate dimensions:
  - Front: 17 x 172 mm.
  - Depth: 255 mm.
- Approximate weight: 335 grams.

**Characteristics are subject to change without notice.**

## 2.14. BC2220 and BC2221. DSP board. Processing, routing and VU meters management.

### General description.

This board takes the data from the TDM IN bus, processes them and sends them to the appropriate TDM OUT bus, depending on the function assigned to the board. There are three types of functions that are internally assigned to DSP boards:

- a) Router: Manages a certain number of inputs and outputs, making crosspoints and modifying gains.
- b) Processor: Performs signal processing tasks.
- c) VU meters: Performs VU meter control tasks.

As many as 20 of these boards can be installed per rack. Depending on the capacities your installation requires, you will need a certain number of BC2220/BC2221 processing boards.

The main difference between BC2220 and BC2221 boards is that the last ones have a higher **process rate**, so the number of DSP boards required for a certain configuration, with a certain request of routing, processing and VU meters management, will be notably lower when you use BC2221 boards.

These boards are inserted into the **front part of the BC2000DF rack**, in the area protected by the front cover.

### Panel description.

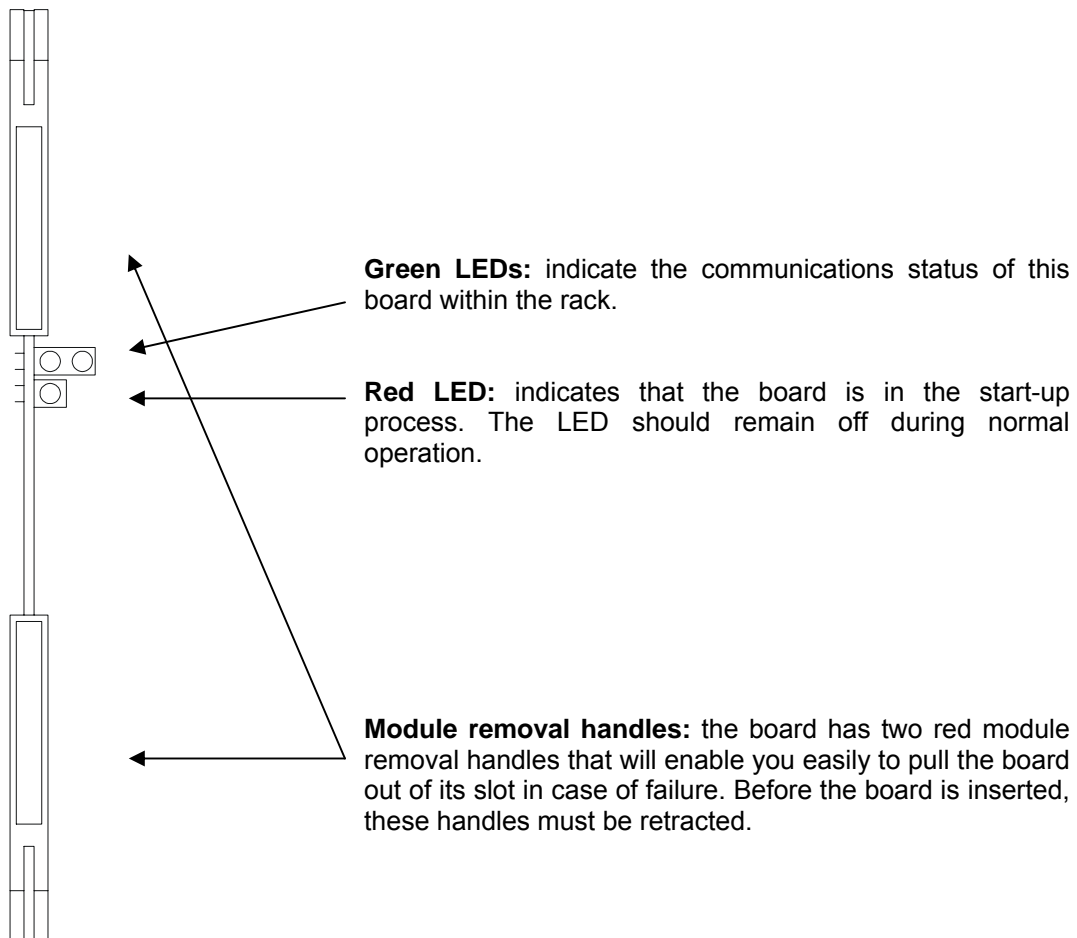

### **Other characteristics and features.**

- Internal warning signal indicating a failure in one of the power supplies. If a failure occurs, the "ALARM" LED on the BC2240 controller board will light up.

### **Programming jumpers.**

This board has a series of internal programming jumpers (PJ). However, these jumpers are configured at the factory and, in normal operation, do not need to be changed.

### **Firmware modules.**

At the firmware level, this board is made up of the following modules:

- **PIC microcontroller:** manages board communications and start-up.
- **FPGA programmable device:** manages the TDM bus.
- **Digital DSP signal processor:** performs signal processing.

The firmware versions can be brought up to date by using the "**BC2000D Firmware Upgrade**" software application.

**IMPORTANT NOTE:** there are specific firmware versions for each type of board and, besides, there are different versions depending on the BC 2000 D system working mode as a mixing console or as a switching matrix of 512x512 or 1024x1024 channels.

### **General characteristics.**

- Approximate consumption: 4 watts.
- Approximate dimensions:
  - Front: 14 x 150 mm.
  - Depth: 255 mm.
- Approximate weight: 180 grams.

**Characteristics are subject to change without notice.**

## **2.15. BC2240. Master Controller Module with USB, Ethernet and RS232/RS422 port.**

### **General description.**

BC2000D system controller. You can insert two controllers in the same rack for redundancy purposes so that, if the main controller fails, the other will take over the control of the system.

This board is inserted into the rear part of the BC2000DF rack.

### **Functional description.**

The controller board is in charge of:

- managing the timing of the entire system, centralizing the synchronization sources.
- managing the power supply alarms generated in any of the boards, lighting the "ALARM" LED if it detects a failure.
- managing the master/slave mode (when two controller boards are used).
- it supplies the entire rack with power when a BC2290 or BC2291 external power supply is used.
- it includes a PC board with a real-time QNX operating system that is stored in a 512-Mb Compact Flash memory. This flash memory contains both the operating system and the configuration data.
- it allows you to record and play identification audio messages from PC board to/from the system through an ISA interface.

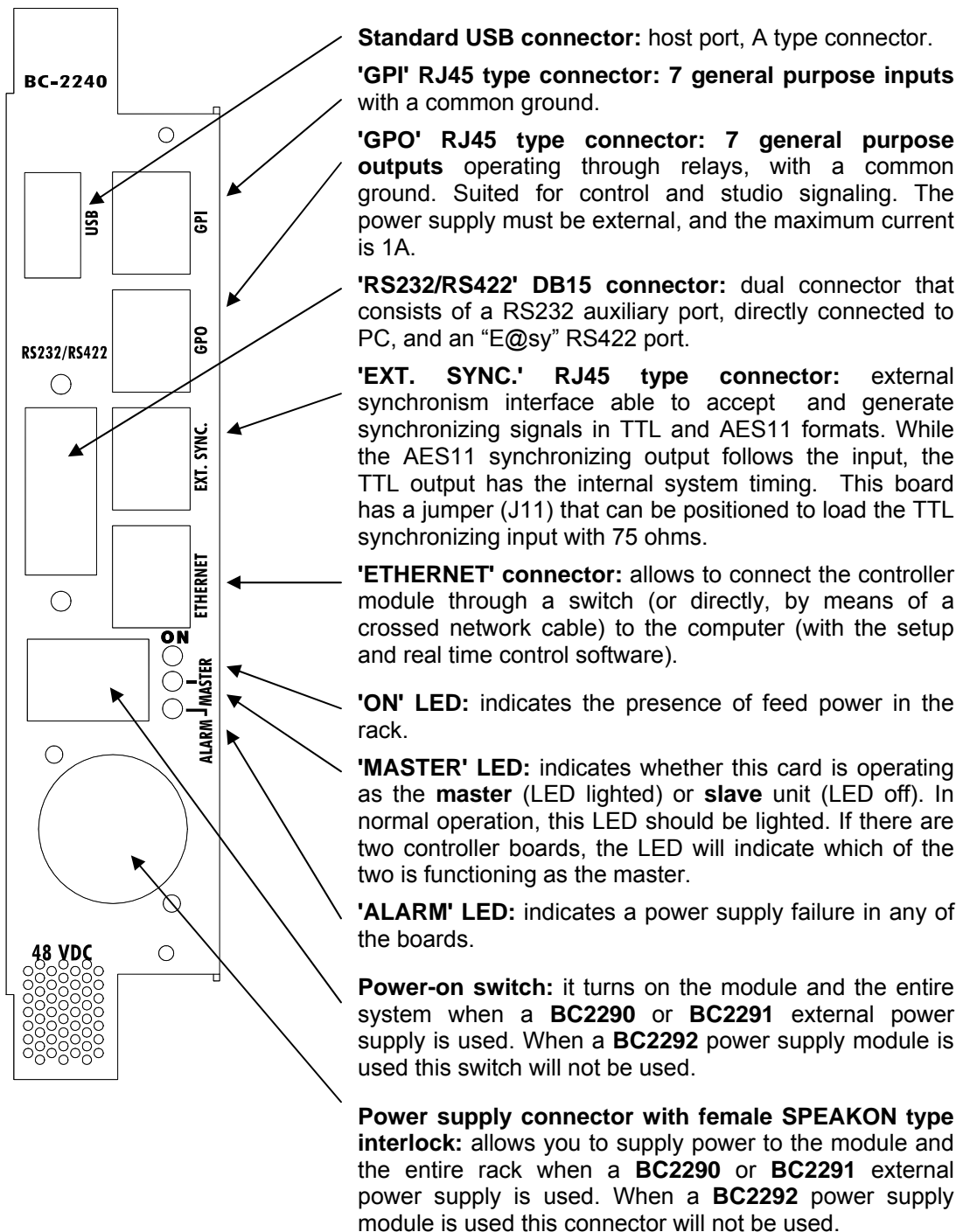

### Firmware modules.

At the firmware level, this board is made up of the following modules:

- **PIC microcontroller:** manages board communications and start-up.
- **FPGA programmable device:** manages the alarms and the TDM bus.

The firmware versions can be brought up to date by using the "BC2000D Firmware Upgrade" software application.

### Signal layout in the RJ 45 connectors of the board.

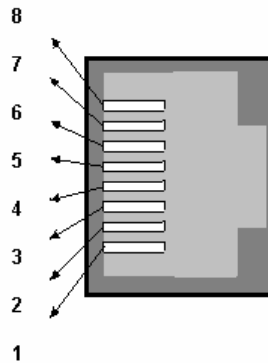

	'GPI'	'GPO'	'EXT. SYNC.'
8	GPIGND	GPOGND	AES SYNC IN-
7	GPI7	GPO7	AES SYNC IN+
6	GPI6	GPO6	AES SYNC OUT-
5	GPI5	GPO5	AES SYNC OUT+
4	GPI4	GPO4	AGND
3	GPI3	GPO3	TTL SYNC OUT
2	GPI2	GPO2	TTL GND
1	GPI1	GPO1	TTL SYNC IN
Rack	GND	GND	GND

### BC2240 technical specifications.

External synchronism: AES3 and TTL.

#### GPI inputs:

- Inputs protected by optocoupler (4N35).
- Maximum input current: 60 mA.
- A voltage ranging between 5 V and 30 V will be applied.

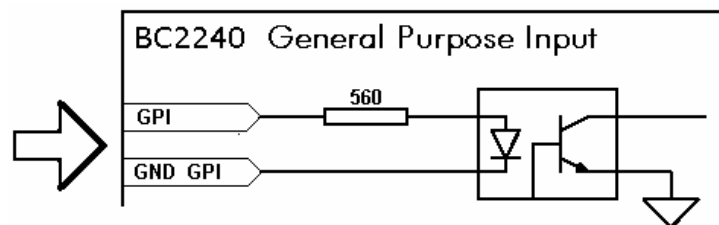

#### GPO outputs:

- By bistable relay (contact closing).
- Maximum current: 1 A @ 30 V DC, 0.5 A @ 125 V AC.
- Maximum voltage: 110 V DC or 125 V AC.
- Maximum power: 30 W, 62.5 VA.

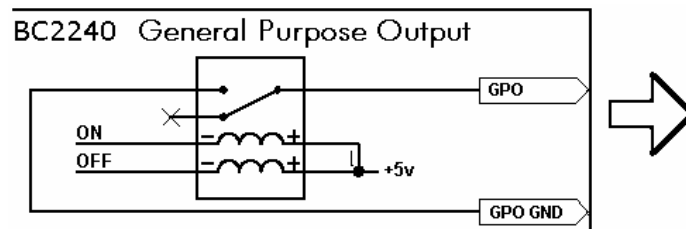



**General characteristics.**

- Approximate consumption: 10 watts.
- Approximate dimensions:
  - Front: 34 x 172 mm.
  - Depth: 255 mm.
- Approximate weight: 658 grams.

**Characteristics are subject to change without notice.**

## 2.16. BC2250. Front control panel.

### General description.

The front control panel of the system allows you to activate/deactive remotely (with no need to use the real-time control software) the previously defined macros and gives you access to system status information.

This panel is connected into the **front part of the BC2000DF rack.**

### Panel description.

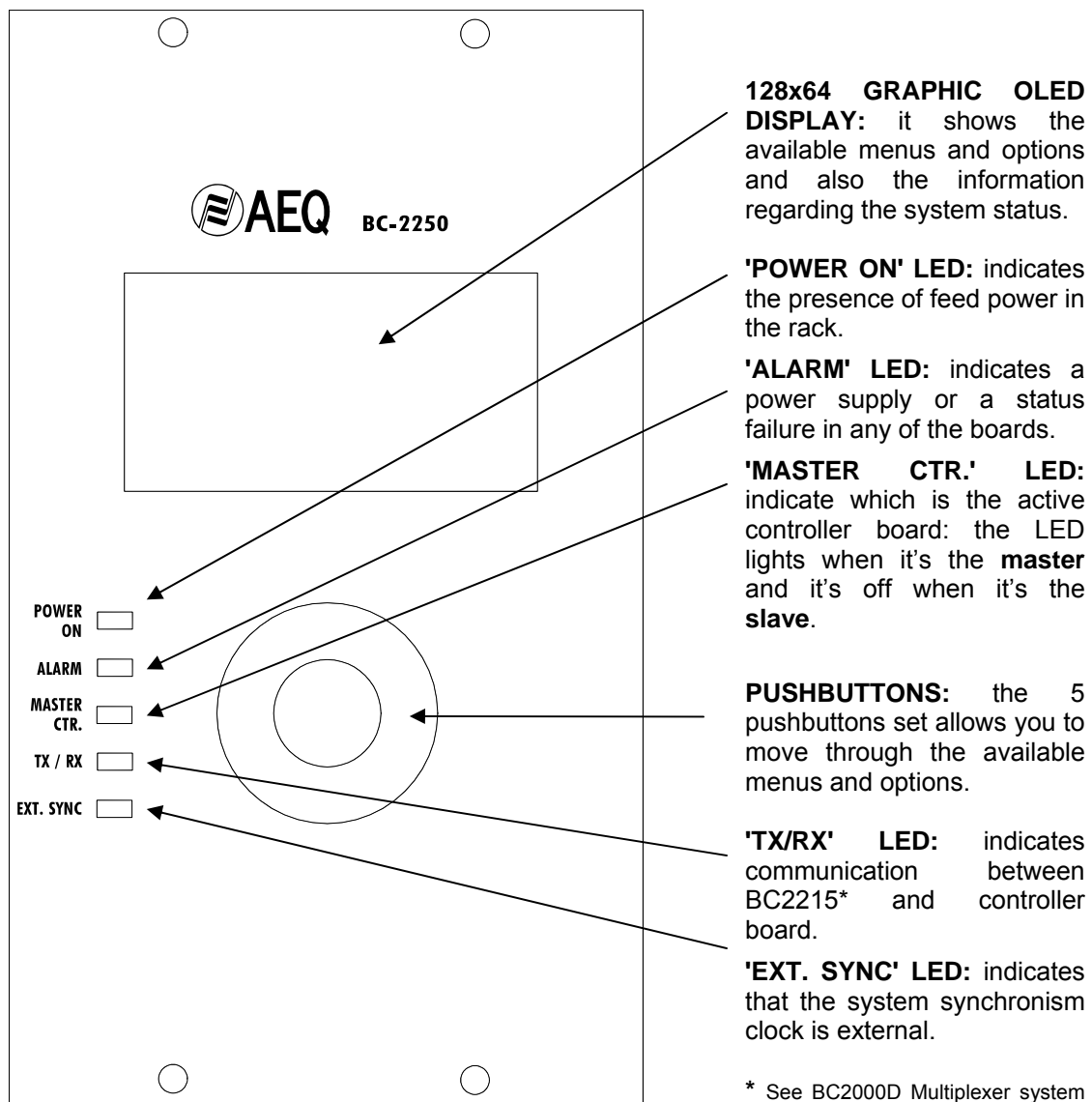

### **Firmware modules.**

At the firmware level, this board is made up of the following module:

- **PIC microcontroller:** manages board communications and start-up.

The firmware versions can be brought up to date by using the "**BC2000D Firmware Upgrade**" software application.

### **General characteristics.**

- Approximate consumption: 7 watts.
- Approximate dimensions:  
Front 99.5 x 172 mm.

**Characteristics are subject to change without notice.**

## 2.17. BC2290. 2x300W Power Supply.

### General description.

BC2000D system power supply. Delivers up to 300 watts between 1 and 10 48 V DC outputs. This power supply is equipped with two 300-watt converters, one of which is normally operational while the other serves as a redundant back-up unit. The converters are accessible from the front panel and can be hot-swapped without having to power down the entire system.

### Front Panel Description.

Two '**PS1**' and '**PS2**' covers give access to the two converters.

Two '**PS1-DC OK**' and '**PS2-DC OK**' LEDs indicate the operation of these two converters.

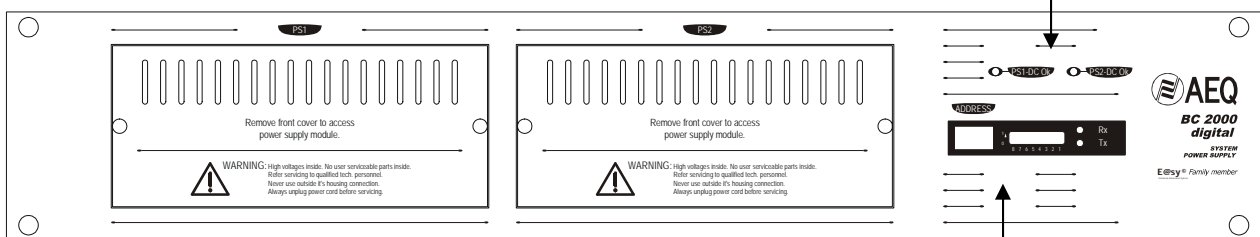

The '**ADDRESS**' display and the microswitches allows you to configure the identification number (node) when the power supply is used for an E@sy system.

They are not used for BC2000D system.

### Rear Panel Description.

Uses connectors with SPEAKON type interlock.

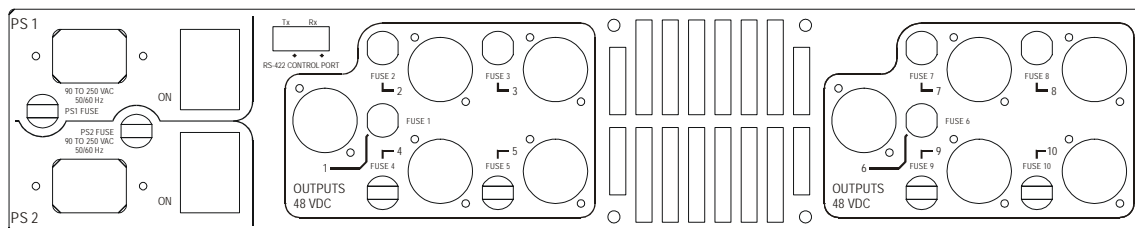

Associated with each of the SPEAKON connectors is a fuse carrier holding a 5-Ampere Type T (timed) protective fuse.

### Technical characteristics.

- Power supply: Autoranging, from 90 to 250 VAC, 50/60Hz, with automatic power factor correction.
- Output voltage: 48 volts DC.
- Maximum power: 300 W.
- Height: 2U.
- Depth: 34 cm.
- Weight: 8 kg.

**Loading of power receivers type-approved for BC 2290.**

To calculate the number of equipment items that can be connected to this power supply, add the estimated power consumption values for all the equipment and boards, leaving a 30-watts safety margin.

<u>Device</u>	<u>Estimated consumption</u>
BC2240 board	10 W
BC2250 board	7 W
BC2201 board	9 W
BC2202 board	4 W
BC2203 M board	6 W
BC2203 MH board	7.5 W
BC2204/BC2205 board	9 W
BC2206/BC2207 board	4 W
BC2208 board	6 W
BC2209 board	8 W
BC2211 board	8.5 W
BC2212 board	10.5 W
BC2220/BC2221 board	4 W

## 2.18. BC2291. 350W Power Supply.

### General description.

BC2000D system power supply. Delivers up to 350 watts between 2 48 V DC outputs.

### Front Panel Description.

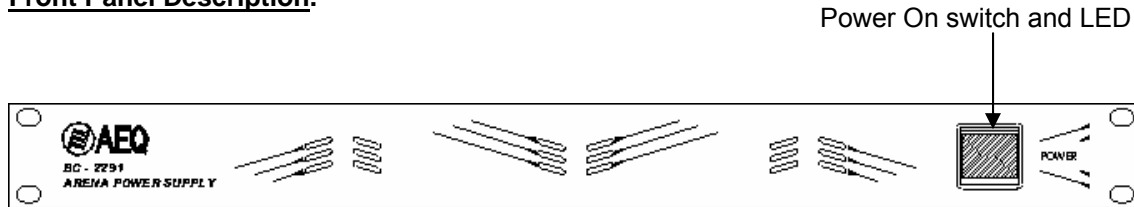

### Rear Panel Description.

Uses connectors with SPEAKON type interlock.

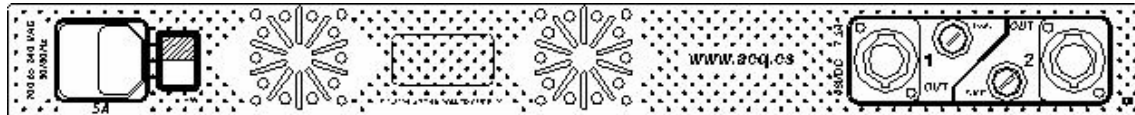

Associated with each of the SPEAKON connectors is a fuse carrier holding an 8-Ampere Type T (timed) protective fuse.

### Technical characteristics.

- Power supply: Autoranging, from 90 to 250 VAC, 50/60Hz.
- Output voltage: 48 volts DC.
- Maximum power: 350 W.
- Height: 1U.
- Depth: 121 mm.
- Weight: 3 kg.

### Loading of power receivers type-approved for BC 2291.

To calculate the number of equipment items that can be connected to this power supply, add the estimated power consumption values for all the equipment and boards, leaving a 30-watts safety margin.

<u>Device</u>	<u>Estimated consumption</u>
BC2240 board	10 W
BC2250 board	7 W
BC2201 board	9 W
BC2202 board	4 W
BC2203 M board	6 W
BC2203 MH board	7.5 W
BC2204/BC2205 board	9 W
BC2206/BC2207 board	4 W
BC2208 board	6 W
BC2209 board	8 W
BC2211 board	8.5 W
BC2212 board	10.5 W
BC2220/BC2221 board	4 W

## 2.19. BC2292. 200W Power Supply Module.

### General description.

BC2000D system power supply module. Delivers up to 200 watts. It can feed an entire frame.

You can insert two power supply modules in the same rack for N+1 redundancy purposes so that, if the main one fails, the other one will feed the system.

This board is inserted into the rear part of the BC2000DF rack.

### Panel description.

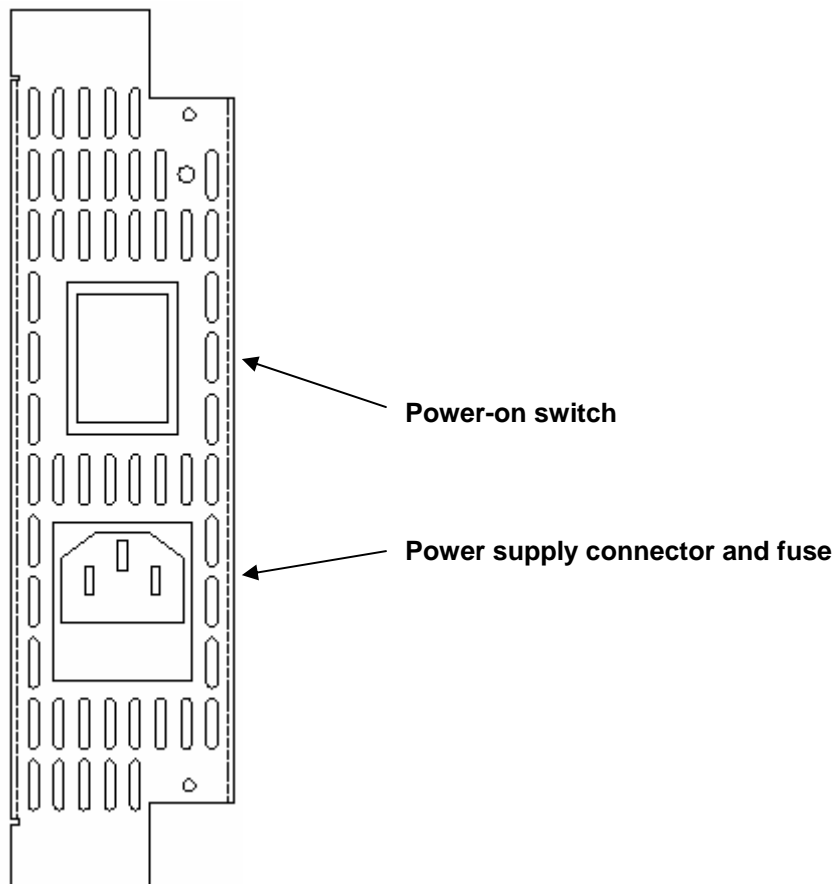

### Technical characteristics.

- Universal input: from 90 to 250 VAC, 50/60Hz.
- Output voltage: 48 volts DC.
- Maximum power: 200 W.
- Approximate dimensions:
  - Front: 43 x 172 mm.
  - Depth: 145 mm.

**Loading of power receivers type-approved for BC 2292.**

To calculate the number of equipment items that can be connected to this power supply, add the estimated power consumption values for all the equipment and boards, leaving a 30-watts safety margin.

<u>Device</u>	<u>Estimated consumption</u>
BC2240 board	10 W
BC2250 board	7 W
BC2201 board	9 W
BC2202 board	4 W
BC2203 M board	6 W
BC2203 MH board	7.5 W
BC2204/BC2205 board	9 W
BC2206/BC2207 board	4 W
BC2208 board	6 W
BC2209 board	8 W
BC2211 board	8.5 W
BC2212 board	10.5 W
BC2220/BC2221 board	4 W



### 3. STANDARD WIRING SYSTEMS FOR BC 2000 D SYSTEM.

Various wiring accessories and kits have been defined to make it easier to make the audio and GPI/GPO connections required by the BC 2000 D consoles and matrixes.

The high degree of integration of the BC 2000 D makes it possible to use 8-pole, high density, RJ45 type connectors on the input and output boards. Each one of these connectors is fitted with four audio or GPI/GPO circuits.

A complete accessory system has been prepared to make crossing connections easier between easily connected, highly integrated 3-pole WAGO connectors or the classic XLR audio connectors and the shielded 8-pole RJ45 connectors accepted by the BC2000DF rack boards.

We have even chosen several types of cable and connectors to supply “loose” to ease the work of wiring a studio equipped with a BC 2000 D system.

#### 3.1. Individual connection components.

The following paragraphs describe the different types of individual elements we offer for wiring the BC 2000 D system.

##### 3.1.1. BC 2000 CAB RACK chassis.

Code 620-000-000. 4 U x 19” connection rack that can house up to:

- 6 BC 2000 CAB W connection modules, each fitted with 12 circuits with WAGO male connectors, or
- 6 BC 2000 D CAB XLR connection modules, each fitted with 4 circuits with XLR connectors which can be male, female, or two male and two female connectors.

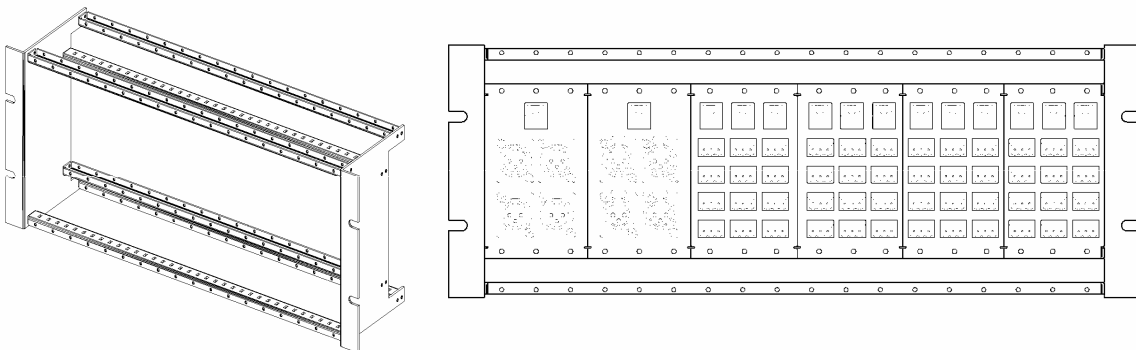

Its special design, with upper and lower slots that permit access to the rear part from the front panel, allows both the 8-pole plus ground RJ45 cables that go to the BC 2000 D rack and the 2-pole plus ground cables that come out of the WAGO or XLR connectors to be led in either from the front or rear panel.

Dimensions: 4 U x 19 “ (482.6 x 178 mm), 120 mm deep.  
Approximate weight: 1,600 grams.

### 3.1.2. BC 2000 CAB W connection modules.

Code 620-000-001. BC 2000 CAB W.

Each connection module allows 3 shielded RJ45 ribbon cables to be connected and led out to the BC2000DF rack boards, and separates the four signals carried by each ribbon cable, taking each one of them to a WAGO 3-pole connector.

The ground pin of the WAGO connector is connected by default to system ground. If this is not appropriate, the ground pin can be isolated removing the necessary programming jumpers located in the back of the module. Programming jumpers J4, J7, J10 y J13 correspond to signals 1, 2, 3 and 4 of the left RJ45 connector. Programming jumpers J5, J8, J11 y J14 correspond to signals 1, 2, 3 and 4 of the central RJ45 connector. Programming jumpers J6, J9, J12 y J15 correspond to signals 1, 2, 3 and 4 of the right RJ45 connector. Programming jumper J16 connects metal chassis to system ground.

Each module is supplied with 12 easily connected WAGO exposed female connectors.

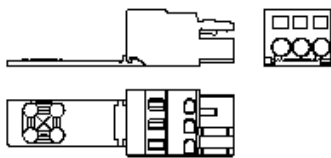

WAGO exposed female 3-pole connector. These connectors have a fast connection mechanism that works by simply inserting the wire, and a security system to ensure the retention of all the wiring.

RJ45 to WAGO conversion examples:

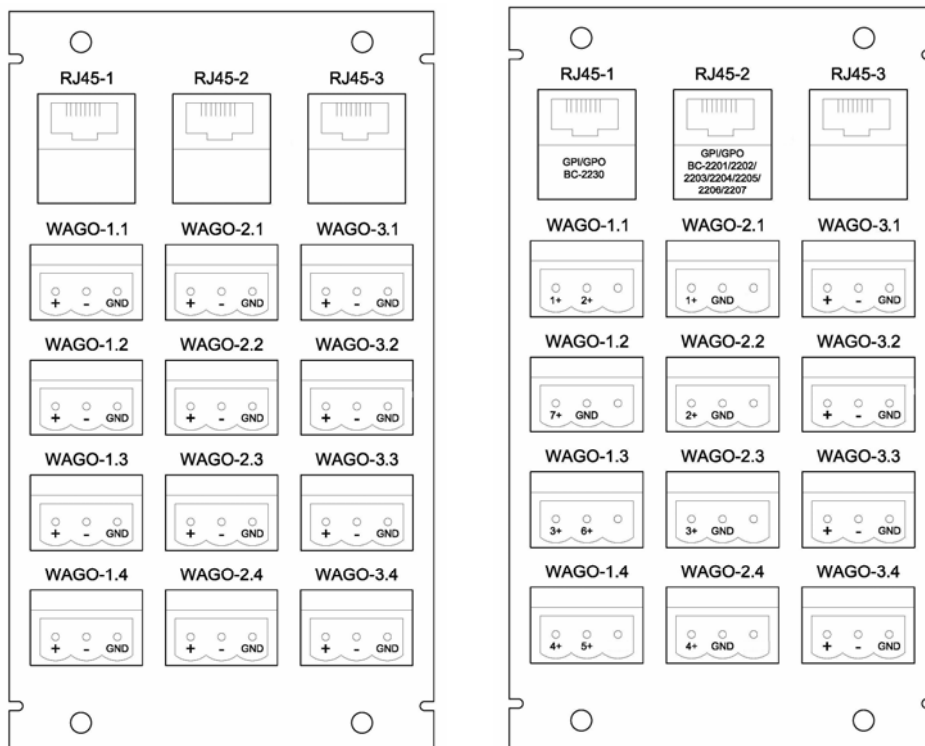

This type of module allows you to connect as many as 72 circuits in a single rack.

Dimensions: 71.6 x 122 mm.  
Approximate weight: 130 grams.

### 3.1.3. RJ45 to 4 XLR connection modules.

- RJ45 to 4 XLR male connection modules. Code 522-900-501
- RJ45 to 4 XLR female connection modules. Code 620-000-002
- RJ45 to 2 XLR female and 2 XLR male connection modules. Code 522-900-503

Each connection module allows one shielded RJ45 ribbon cable to be connected and led out to the BC2000DF rack boards, and separates the four signals carried by the ribbon cable, taking each one of them to a 3-pole XLR connector. You may connect the ground pin of the XLR connector or not, as appropriate; the module has the necessary programming jumpers for this purpose (J1 for circuit 1, J2 for circuit 2 and so on).

The connection modules with XLR connectors male and female looks as follows:

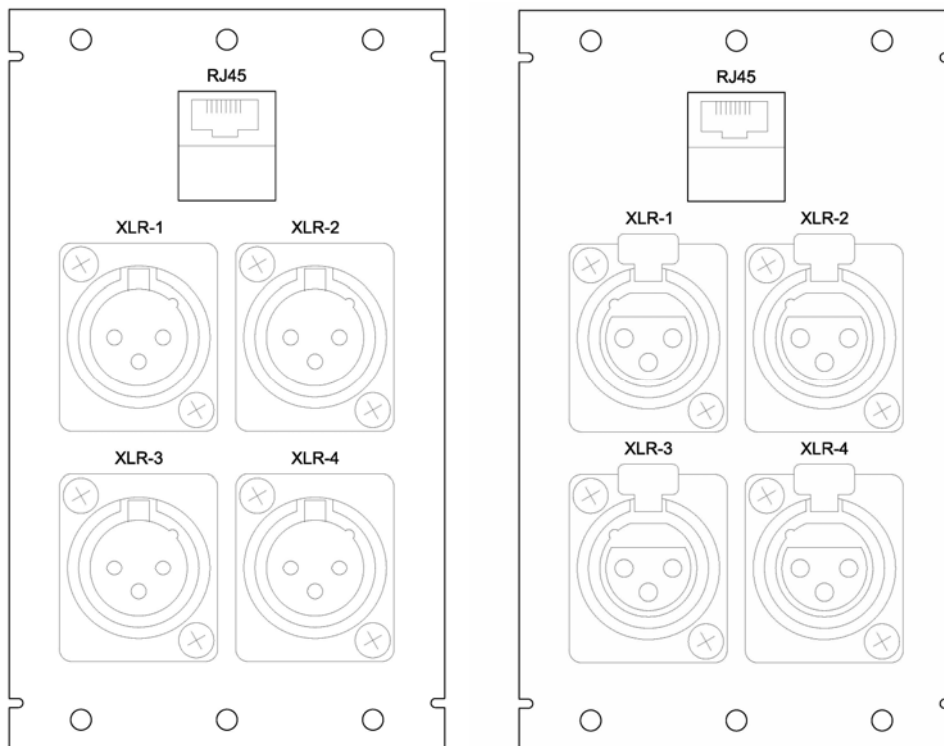

This type of module allows you to connect a maximum of 24 circuits in each rack.

XLR connector pin-out:

- Pin 1: GND
- Pin 2: V+
- Pin 3: V-

Dimensions: 71.6 x 122 mm.  
Approximate weight: 233 grams.

### 3.1.4. Cables with connectors.

#### RJ45/RJ45 ribbon cables.

Shielded RJ45/RJ45 cables have been defined for installation between the connection module and the BC2000DF rack input and output boards. The 2-meter length is to be used when BC2000DF and BC 2000 CAB RACK are installed next to each other, and the 5-meter length will be used when you prefer to install them at a certain distance from each other.

- Code 522-900-902: RJ45/RJ45 shielded cable, 2 meters.
- Code 522-900-903: RJ45/RJ45 shielded cable, 5 meters.

#### XLR cables to connect audio equipment to the BC 2000 CAB W connectors.

The system supply includes 110-ohm cables in lengths of 4 meters. Optimal for digital and analog audio, these cables are fitted with one male or female XLR connector each, and prepared at the opposite end for insertion into the WAGO connectors included in the BC 2000 CAB W.

The purpose of this accessory is to provide you with cables that are ready to carry the signal from each piece of audio equipment in the studio to the connection rack.



- Code 522-300-103: XLR male RED cable, 4 meters length, for insertion in WAGO male.
- Code 522-300-104: XLR male BLUE cable, 4 meters length, for insertion in WAGO male.
- Code 522-300-105: XLR female RED cable, 4 meters length, for insertion in WAGO male.
- Code 522-300-106: XLR female BLUE cable, 4 meters length, for insertion in WAGO male.

### 3.1.5. Loose cables and connectors.

Listed below are some types of cables and connectors that are highly useful for wiring BC 2000 D systems in radio studios.

Apart from this, the AEQ catalog offers different 110-ohm multipair cable packs for digital and analog audio.

- 341-001-023: XLR exposed male connector.
- 341-001-013: XLR exposed female connector.
- 114-005-068 (PA-03 DR): Balanced 110-ohm red cable (100-meter reel).
- 114-005-069 (PA-03 DA): Balanced 110-ohm blue cable (100-meter reel).
- 114-005-067 (PA-03 DG): Balanced 110-ohm grey cable (100-meter reel).
- 114-005-011 (MI-206 N): Black microphone cable (100-meter reel).
- 114-005-012 (MI-206 R): Red microphone cable (100-meter reel).
- 114-005-013 (MI-206 A): Blue microphone cable (100-meter reel).

## **3.2. Wiring kits for BC 2000 D system.**

### **3.2.1. Standard wiring kit.**

Given below is the “Standard wiring kit” diagram showing the configuration of the wiring, racks and modules for a console of typical dimensions.

The description covers everything from the BC2000DF rack to the WAGO exposed 3-pole female connectors.

The great flexibility of the configuration will enable you to use it for other similar configurations and will allow easy expansions with the individual components described above.

Code 522-300-100. BC 2000 CAB STD: Standard wiring kit for the BC 2000 D.

It is made up of:

- BC 2000 CAB RACK: One 4 U x 19” connection rack.
- 5 units of BC 2000 CAB W, 3 RJ45 to 12 Wago connection modules including female connector.
- 1 unit of BC 2000 CAB MF, 1 RJ45 to 4 XLR female connection module.
- 16 units of 2-meter length of shielded RJ45/RJ45 cable.

## DIAGRAM OF THE STANDARD WIRING KIT APPLIED TO A TYPICAL CONFIGURATION OF THE AEQ BC 2000 D CONSOLE

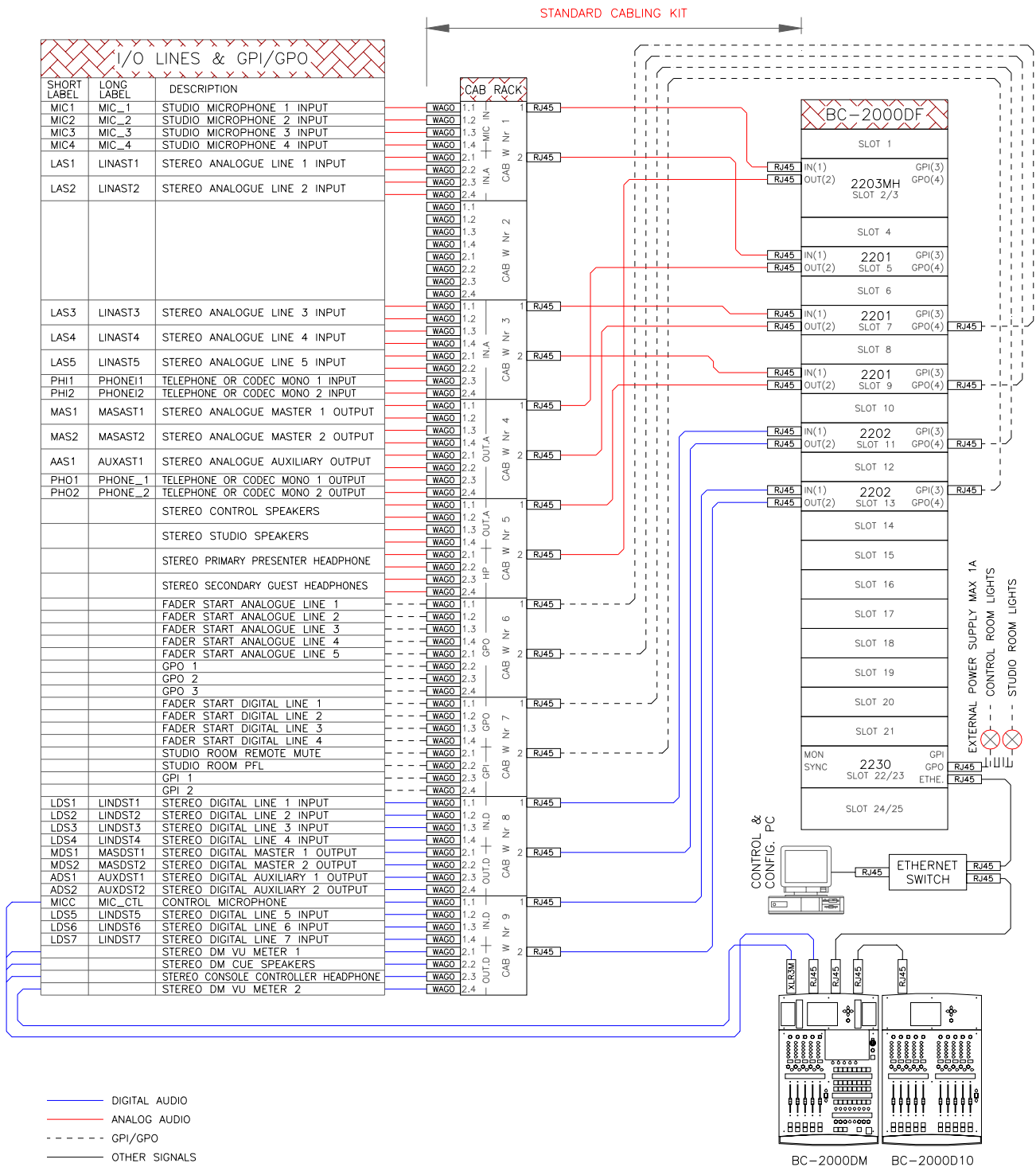

### 3.2.2. Additional control wiring.

To ensure that you will have the additional elements needed for wiring everything from the control equipment to the WAGO exposed female connectors that are supplied with the BC 2000 CAB W panels, we offer two additional component kits made up of cables for digital and analog audio and connectors. The two kits are alternatives; you will find one better suited to your needs than the other:

- **Additional control wiring kit for the standard BC 2000 (code 522-300-101).**  
This kit is composed of cables and connectors you will need to custom-make each control cable:
  - One 100-meter reel of PA 03 DR red cable.
  - One 100-meter reel of PA 03 DA blue cable.
  - 25 male XLR connectors.
  - 25 female XLR connectors.
  
- **Additional control pre-wiring kit for the standard BC 2000 (code 522-300-102).**  
This kit is composed of 32 prefabricated cables for the audio equipment items and more cable and other connectors for making the rest of the control cables:
  - 16 four-meter lengths of XLR male cable, BLUE, for insertion into male Wago.
  - 16 four-meter lengths of XLR male cable, RED, for insertion into male Wago.
  - One 100-meter reel of PA 03 DG gray cable.
  - 5 male XLR connectors.
  - 5 female XLR connectors.

#### **4. SWITCH.**

We strongly recommend, as shown in the standard configuration diagram, connecting the different consoles and racks, as well as a computer with the setup software, through a switch in each BC 2000 D installation. Any good quality switch can be used. If you are not sure which product to choose for the best operation, we offer a good AEQ-compatible switch which is available as a stand-alone or rack-mountable unit (1 U x 19") with universal power supply.

Code 390-003-181: Ethernet Switch, 16 ports, stand-alone or 1 U x 19 ".

When a direct connection (without switch) is established between the DM control surface and the frame, a crossed network cable should be used.



## 5. CONTROL SURFACES.

Only for wiring purposes, the ARENA DM and ARENA D10 control surfaces are described below. This equipment is described at a functional level in the relevant manual, which is written with the users in mind. In order to understand the connections better, refer to the diagram in section 3.2.1.

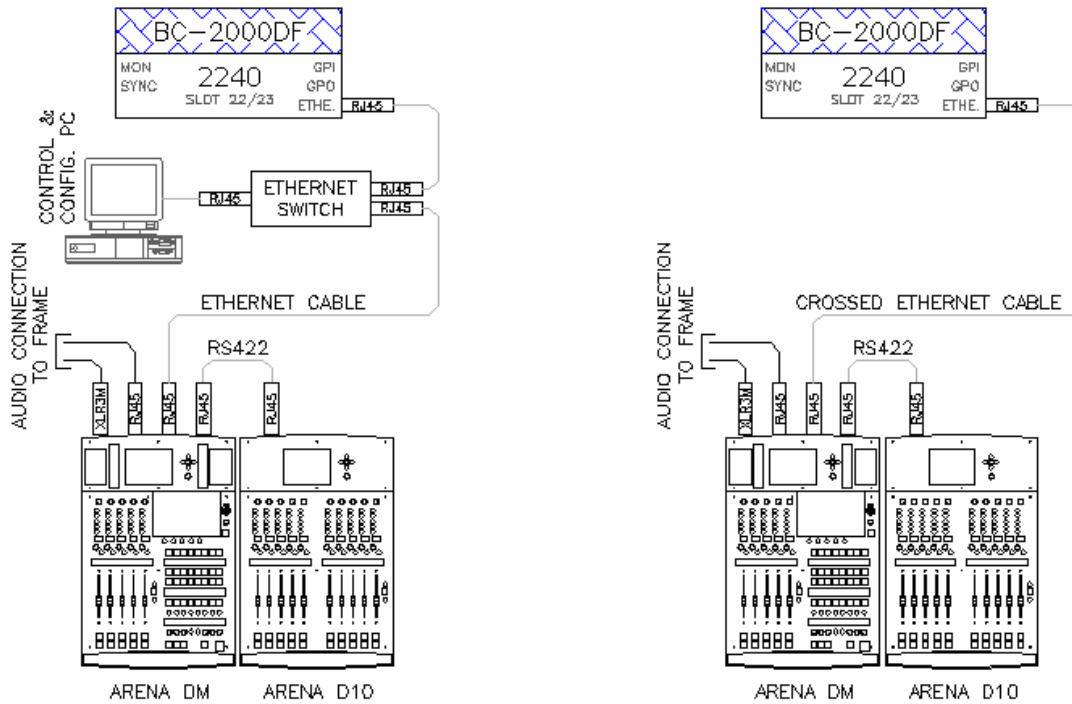

## 5.1. ARENA DM control module.

### Composition of the supply \*

- The module itself.
- One 2-meter power supply cable.
- 5-meter flexible, shielded, crossed local network cable to connect frame and console without switch.

\* Console installation guide and CD with control surface setup software, firmware and complete console manuals are included in the Frame supply.

### Connection and other rear panel elements.

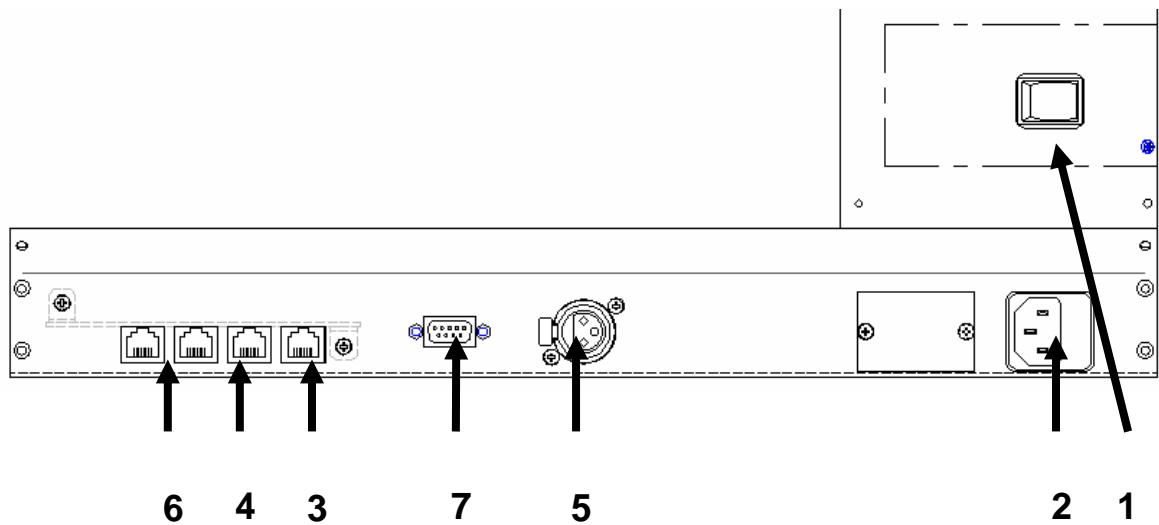

- 1. Power switch.
- 2. Power supply connector and fuse.
- 3. Ethernet LAN: Connector linking data with the controller: a standard Ethernet cable can be connected when connecting through a switch, or the crossed network cable that is supplied (labeled “Only direct to controller”) can be used when a direct connection is made.
- 4. RJ45 digital audio conector: Connects the digitalized output from the mic input and the inputs for VU meter 1, CUE and the control headphones. Cable is furnished to connect to BC 2000 CAB W. Pin layout, from right to left, with the tongue facing up:

1. AES VU1 In+:	AES/EBU audio input for VU meter 1.
2. AES VU1 In-:	AES/EBU audio input for VU meter 1.
3. AES CUE In+:	AES/EBU audio input for CUE.
4. AES Headph In+:	AES/EBU audio input for the control headphones.
5. AES Headph In-:	AES/EBU audio input for the control headphones.
6. AES CUE In-:	AES/EBU audio input for CUE.
7. AES MIC Out+:	AES/EBU audio output from the ARENA DM microphone.
8. AES MIC Out-:	AES/EBU audio output from the ARENA DM microphone.

- **5.** AES/EBU digital audio connector by XLR, to receive the input from VU meter 2.
  1. GROUND.
  2. AES VU2 In +: AES/EBU audio input for VU meter 2.
  3. AES VU2 In -: AES/EBU audio input for VU meter 2.
  
- **6.** Pair of RS 422 control output RJ45 connectors for ARENA D10 channel expansion modules: 2 connectors. If you need to connect more (up to 7), each connector has a follower output that can be connected to the next one. Pin layout, from right to left, with the tongue facing up:
  3. RX +.
  4. TX +.
  5. TX -.
  6. RX -.
  7. S clk +: V+ phase of the synchronizing signal.
  8. S clk -: V- phase of the synchronizing signal.
  
- **7.** RS 232: serial Port: Connection via serial port for future applications.

## 5.2. ARENA D10 channel expansion module.

### Composition of the supply.

- The module itself.
- One 2-meter power supply cable.
- Flexible shielded RJ45/RJ45 cable for ARENA D10, 2 meters long.

### Connection and other rear panel elements.

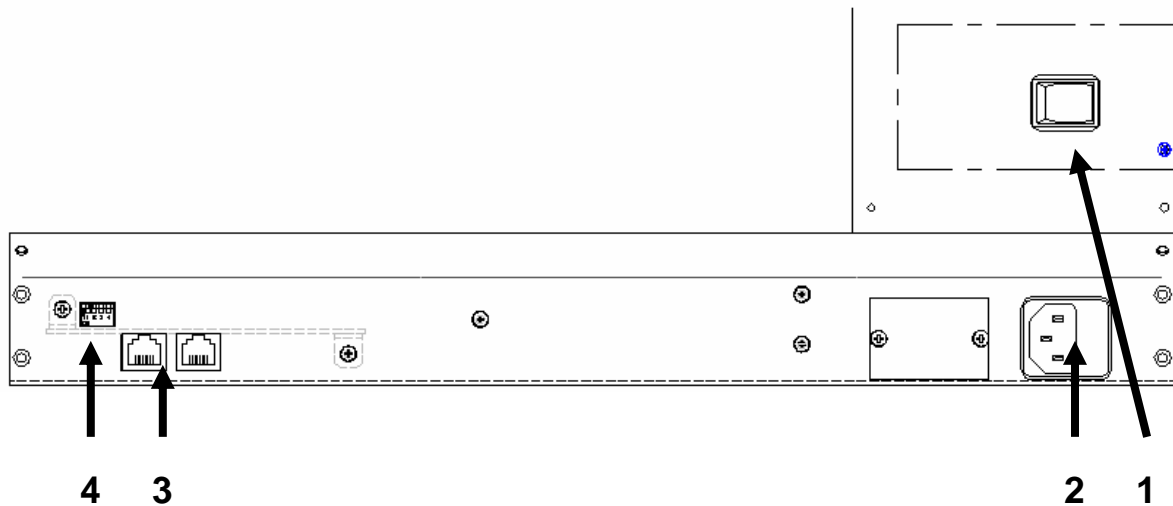

- 1. Power switch
- 2. Power supply connector and fuse.
- 3. Pair of RJ 45 input and output connectors, where output follows the RS 422 control from the main ARENA DM module and toward others, for ARENA D10 channel expansion modules. Pin-to-pin connection (the cable furnished with each module can be used), since the pin layout is inverted in the equipment. Pin layout, from right to left, with the tongue facing up:
  - 3. TX +.
  - 4. RX +.
  - 5. RX -.
  - 6. TX -.
  - 7. S clk +: V+ phase of the synchronizing signal.
  - 8. S clk -: V- phase of the synchronizing signal.
- 4. Dip-Switch module. These switches are used to assign a different address to each ARENA D10 module that hangs from a ARENA DM, to prevent communications from colliding. Make sure, therefore, that in each ARENA D10 the position of the set of dip-switches is different from all the rest of the dip-switches.