

---

# 1-Wire Mains Switch

User Manual

---

## Table of Contents

<b>1</b>	<b>Features</b>	<b>3</b>
<b>2</b>	<b>Technical Specifications</b>	<b>3</b>
<b>3</b>	<b>Safety Precautions</b>	<b>4</b>
<b>4</b>	<b>1-Wire Mains Switch</b>	<b>5</b>
	Board Overview	5
	1-Wire Terminal Block Connector (K2)	5
	1-Wire RJ45 Connectors (K3, K4)	6
	1-Wire Slave Power Selection (J1)	6
	Mains Connector (K1)	7
	1-Wire Connectivity	7
	Communications Protocol	8
<b>5</b>	<b>Software Support</b>	<b>10</b>
	ows	10
	owfs	10
<b>6</b>	<b>Application Notes</b>	<b>11</b>
<b>7</b>	<b>Disclaimer</b>	<b>11</b>
<b>8</b>	<b>Contact Information</b>	<b>11</b>

## Revision History

<b>Date</b>	<b>Authors</b>	<b>Description</b>
2013-03-14	Peter S'heeren	Initial release.
2013-04-28	Peter S'heeren	Added extra safety precaution. Added section about software support. Second release.
2013-07-21	Peter S'heeren	Added section about owfs software support. Third release.

## 1 Features

- Available in 230 V and 120 V versions.
- Reinforced safety insulation between mains voltage and one wire bus.
- Low power consumption, typically less than 400 mW.
- Three connection points for 1-Wire cabling and wiring.

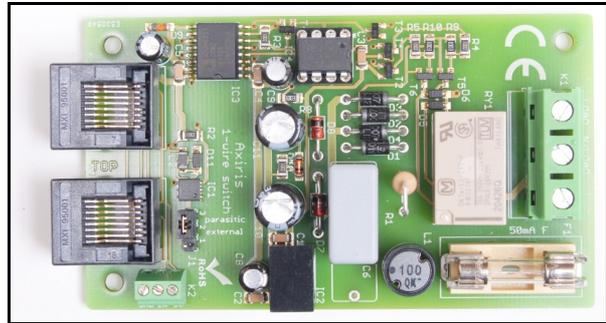

## 2 Technical Specifications

<b>Weight</b>	47 g (with fuse)
<b>Dimensions</b>	96 mm x 54 mm x 18 mm (W x D x H)

### 3 Safety Precautions

#### **SAFETY PRECAUTIONS**

DO NOT TOUCH THE DEVICE WHEN IT IS CONNECTED TO MAINS VOLTAGE.

DO NOT MOUNT OR PLACE THE DEVICE CLOSE TO INFLAMMABLE MATERIALS.

USE A FUSE OF 50 mA ONLY.

THE LOAD CIRCUIT MUST BE PROTECTED BY AN EXTERNAL FUSE OF MAX. 10 A.

DO NOT USE THE DEVICE WITH APPLIANCES THAT MAY CAUSE DANGER WHEN SWITCHED ON OR OFF UNINTENDEDLY.

AFTER BEING DISCONNECTED FROM THE MAINS VOLTAGE, CAPACITOR C6 MAY REMAN CHARGED. THE DEVICE MAY GENERATE A HARMLESS BUT UNPLEASANT ELECTRIC SHOCK WHEN YOU TOUCH THE MAINS CONNECTOR K6.

It's recommended to house the device in an earthed metal case.

## 4 1-Wire Mains Switch

### Board Overview

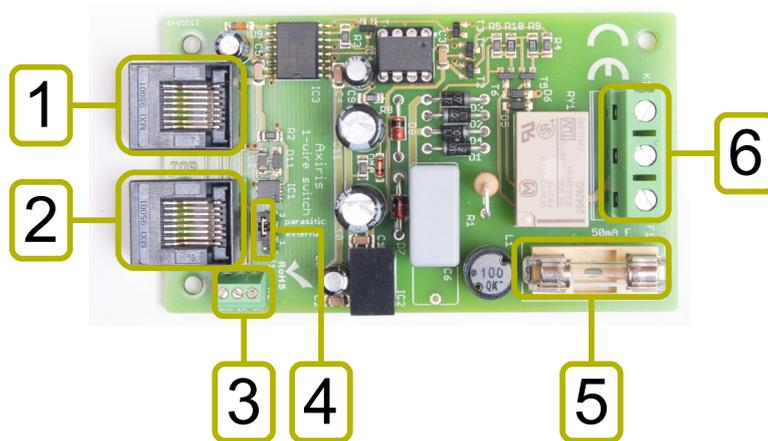

Mark	Label	Description
1	K3	1-Wire bus RJ45 connector
2	K4	1-Wire bus RJ45 connector
3	K2	1-Wire bus terminal block connector
4	J1	Power supply selection for the 1-Wire slave
5	F1	Fuse of 50 mA (mandatory; do not use another value)
6	K1	Mains connector

### 1-Wire Terminal Block Connector (K2)

Mark	Description
5V	5 V supply
1W	1-Wire DQ line (data)
GND	Ground

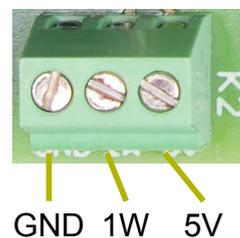

### 1-Wire RJ45 Connectors (K3, K4)

Mark	Description
1	Unassigned
2	+5 V power
3	Unassigned
4	1-Wire DQ (data)
5	1-Wire ground
6	Unassigned
7	Unassigned
8	Unassigned

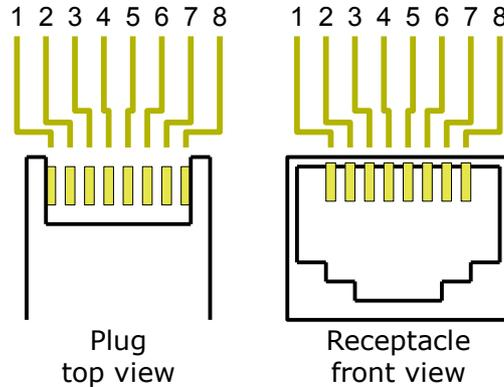

All eight pins are routed between the two connectors. The device doesn't use the unassigned lines.

### 1-Wire Slave Power Selection (J1)

1	2	3	Description
<input checked="" type="checkbox"/>	<input type="checkbox"/>	<input type="checkbox"/>	External power
<input type="checkbox"/>	<input checked="" type="checkbox"/>	<input type="checkbox"/>	Parasite power

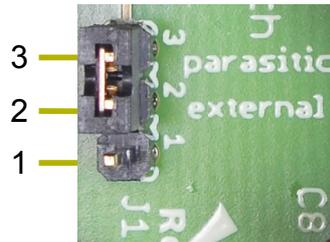

This jumper determines how the 1-Wire slave is powered:

- External power: the 1-Wire slave draws power from the mains circuit.
- Parasite power: the 1-Wire slave uses an internal capacitor as its power source. The capacitor is charged during idle time (DQ line held high) and provides power during bus activity.

Note: The 5V line (K2, K3, K4) is never applicable.

See the 1-Wire specification for more information.

## Mains Connector (K1)

Mark	Description
LOAD	Load being switched
N/LOAD	Neutral Load being switched
L	Phase

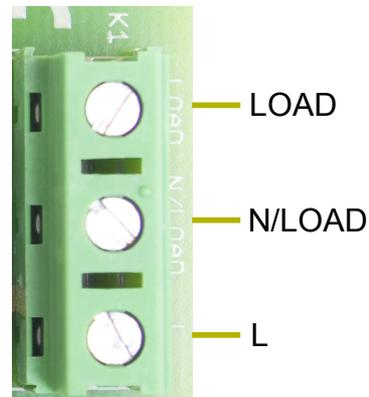

Connect the 230 V or 120 V mains between N/LOAD and L.

The load being switched must be connected between LOAD and N/LOAD.

For reasons of safety, make sure you connect the phase conductor and the neutral conductor correctly.

## 1-Wire Connectivity

The 1-Wire Mains Switch provides three connection points for 1-Wire cabling and wiring.

The terminal block connector is typically used for wiring the 1-Wire Mains Switch to an AbioWire or another 1-Wire adapter.

The RJ45 receptacles provide a means to set up a 1-Wire bus in daisy chain using UTP cables.

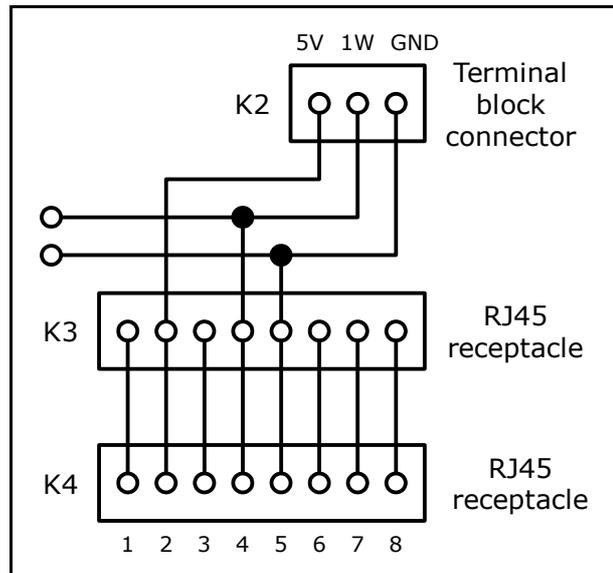

### Communications Protocol

The 1-Wire slave function on the 1-Wire Mains Switch is a Maxim DS2406 chip. The 1-Wire slave is connected to the switch controller.

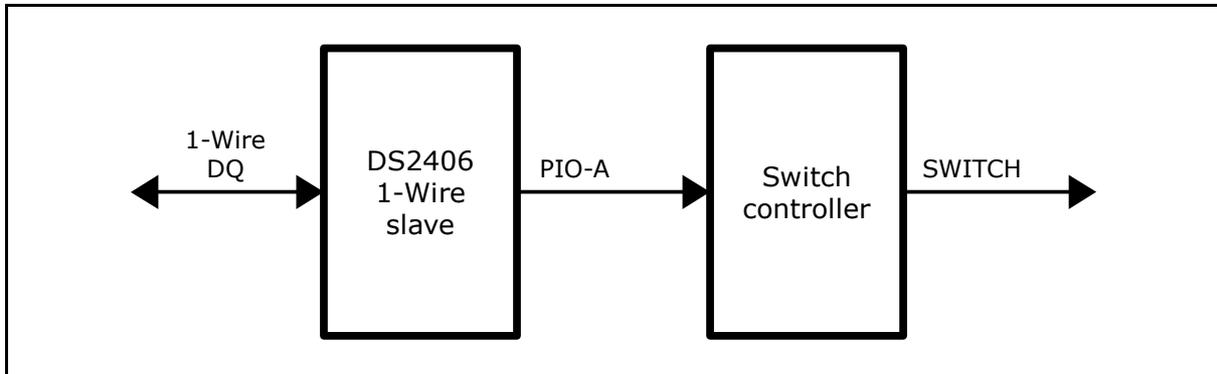

See the Maxim DS2406 datasheet for more information about the 1-Wire slave chip.

The switch controller interprets the PIO-A input as negative logic. Doing so insures the switch is turned off when the DS2406 is in the reset state.

The family code of the DS2406 is 12h. Since the family code alone doesn't uniquely identify a 1-Wire Mains Switch device, the host system must associate the full 8-byte ROM code with the device.

The following diagram shows how to turn on the switch.

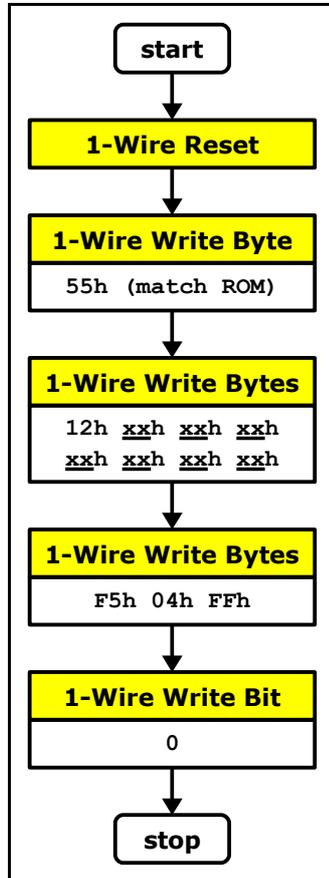

The following diagram shows how to turn off the switch.

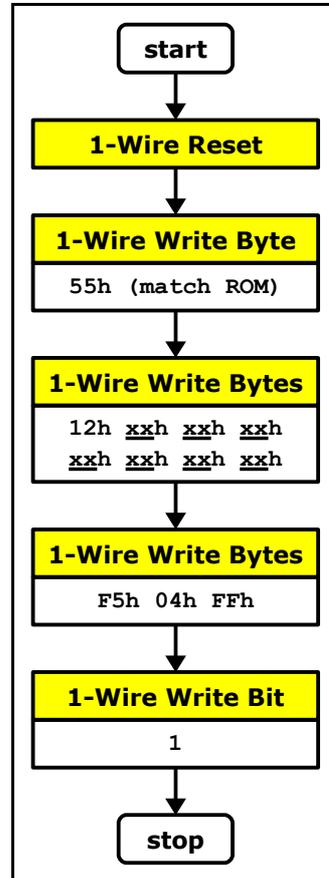

## 5 Software Support

### ows

Software package **ows** v1.0.0 and later includes program **owswitch**. This program enables you to fully control the 1-Wire Mains Switch.

Example invocations of the program:

```
# ./owswitch -i2cdev /dev/i2c-0 ds2482 24 -ch 7 -id 12-974696 -on
```

This command turns on the switch. The device is supposed to be connected to channel 7 of the DS2482-800 chip.

```
> owswitch.exe -lu -pr -id 12-974696 -off
```

This command probes the 1-Wire Mains Switch on all USB-to-1-Wire adapters. If found, the program turns off the switch.

### owfs

It's assumed you're using the filesystem client of the **owfs** package. In the examples it's suppose you've specified **/mnt/onewire/** as the mount directory for the 1-Wire file system.

Since owfs inverts all accesses to PIO channels, the default negative logic becomes positive logic.

```
# echo "1" > /mnt/onewire/12.964697000000/PIO.A
```

This command turns on the switch.

```
# echo "0" > /mnt/onewire/12.964697000000/PIO.A
```

This command turns off the switch.

## 6 Application Notes

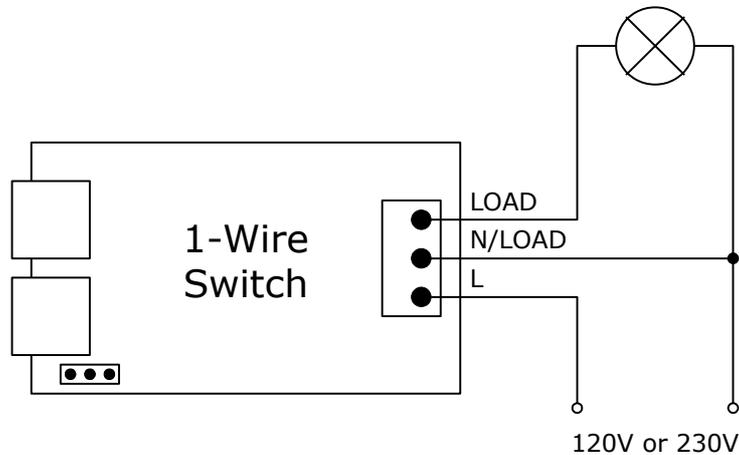

## 7 Disclaimer

Axiris products are not designed, authorized or warranted to be suitable for use in space, nautical, space, military, medical, life-critical or safety-critical devices or equipment.

Axiris products are not designed, authorized or warranted to be suitable for use in applications where failure or malfunction of an Axiris product can result in personal injury, death, property damage or environmental damage.

Axiris accepts no liability for inclusion or use of Axiris products in such applications and such inclusion or use is at the customer's own risk. Should the customer use Axiris products for such application, the customer shall indemnify and hold Axiris harmless against all claims and damages.

## 8 Contact Information

Official website: <http://www.axiris.be/>

