

SHARP[®]

Version 2.1
Produced in March. 1998

SHARP Programmable Controller

Model Name

ME-NET module

JW-20MN

Instruction Manual

Thank you for purchasing the ME-NET module (JW-20MN) for the SHARP programmable controller. Read this manual thoroughly to completely familiarize yourself with the operation according to the examples.

Keep this manual for future reference. We are confident that this manual will be helpful whenever you encounter a problem.

Note

★ This manual describes the JW-20MN with [30Hn] mark in front of the module. The new functions is added for the JW-20MN without [30Hn] marks.

In this manual, additional functions are represented by the [V5] mark.

★ In this manual, programmable controller is referred to as "PC." Number and symbol in parentheses added to address or setting value indications represent the following:

Octal·········· (8)

Hexadecimal···· (H)

Decimal········ (D) or no indication

Note

- This manual is written with the utmost care.
- No part of this manual may be reproduced in any form without permission of SHARP corporation.
- The contents of this manual are subject to change without prior notice.

Safety Precautions



Read this manual and attached documents carefully before installation, operation, maintenance and checking in order to use the machine correctly. Understand all of the machine knowledge, safety information, and cautions before starting to use. In this instruction manual, safety precautions are ranked into “danger” and “caution” as follows.



 **Danger** : Wrong handling may possibly lead to death or heavy injury.

 **Caution** : Wrong handling may possibly lead to medium or light injury.

Even in the case of  **Caution**, a serious result may be experienced depending on the circumstances. Anyway, important points are mentioned. Be sure to observe them strictly.

The picture signs of prohibit and compel are explained below.

 : It means don'ts. For example, prohibition of disassembly is indicated as ().

 : It means a must. For example, obligation of grounding is indicated as ().

1) Installation

Caution

- Use in the environments specified in the catalog, instruction manual, and user's manual.
Electric shock, fire or malfunction may be caused when used in the environments of high temperature, high humidity, dusty or corrosive atmosphere, vibration or impact.
- Install according to the manual.
Wrong installation may cause drop, breakdown, or malfunction.
- Never admit wire chips or foreign matters.
Or fire, breakdown or malfunction may be caused.

2) Wiring

Compel

- Be sure to ground.
Unless grounded, electric shock or malfunction may be caused.

Caution

- Connect the rated power source.
Connection of a wrong power source may cause a fire.
- Wiring should be done by a qualified electrician.
Wrong wiring may lead to fire, breakdown or electric shock.

3) Use

Danger

- Don't touch the terminal while the power is being supplied or you may have an electric shock.
- Assemble the emergency stop circuit and interlock circuit outside of the programmable controller. Otherwise breakdown or accident damage of the machine may be caused by the trouble of the programmable controller.

Caution

- "RUN" or "STOP" during operation should be done with particular care by confirming safety. Misoperation may lead to damage or accident of the machine.
- Turn ON the power source in the specified sequence. Turning ON with wrong sequence may lead to machine breakdown or accident.

4) Maintenance

Prohibit

- Don't disassemble or modify the modules.
Or fire, breakdown or malfunction may be caused.

Caution

- Turn OFF the power source before detaching or attaching the module.
Or electric shock, malfunction or breakdown may be caused.

Chapter 1: Outline

Chapter 2: Safety Precautions

Chapter 3: Name and Function of Each Part

Chapter 4: Installation

Chapter 5: Processing of Cables

Chapter 6: Wiring

Chapter 7: Memory Addresses on the ME-NET

Chapter 8: Description of the Data Link Operation

Chapter 9: Description of the Computer Link Operation

Chapter 10: Outline of Switch and Parameter Setting Procedure

Chapter 11: Error and Treatment

Chapter 12: Replacement of the JW-20MN

Chapter 13: Register and Load Parameters

Chapter 14: Specification

Chapter 15: Appendix

Alphabetical Index

Table of contents

Chapter 1: Outline	1·1
1-1 Example of system configuration	1·1
1-2 Function	1·2
Chapter 2: Safety Precautions	2·1
2-1 Installation	2·1
2-2 Wiring	2·1
2-3 Treatment	2·3
2-4 Static electricity	2·3
2-5 Cleaning	2·3
Chapter 3: Name and Function of Each Part	3·1
Chapter 4: Installation	4·1
4-1 Installation of cable for option module	4·1
4-2 Installation of JW-20MN	4·3
Chapter 5: Processing of Cables	5·1
5-1 Processing cable end	5·2
5-2 Connector crimping procedure	5·5
Chapter 6: Wiring	6·1
6-1 Cable trunk and branch lines	6·1
6-2 Relaying of trunk cable	6·1
6-3 Cable wiring procedure in control panel	6·2
6-4 Waterproof and insulation processing of connectors	6·4
6-5 Wiring of cables at outside control panels	6·5
6-6 Check after wiring	6·5
6-7 Wiring method for adding a communication station	6·6
Chapter 7: Memory Addresses on the ME-NET	7·1
7-1 Memory address for data links (link area top address, flag top address)	7·1
7-2 Memory addresses for computer links	7·1
Chapter 8: Description of the Data Link Operation	8·1
8-1 Communication method	8·1
8-2 Data transfer required time and communication delay time	8·4
8-3 Expansion of network	8·7
Chapter 9: Description of the Computer Link Operation	9·1
9-1 Computer link function	9·1
9-2 Communication method	9·2
9-3 Basic command	9·3
9-4 Optional commands	9·5
Chapter 10: Outline of Switch and Parameter Setting Procedure	10·1
10-1 Operation procedure	10·1
10-2 Switch setting of master station and slave station	10·2
10-3 Setting contents of slave station parameters (common for all slave stations)	10·6
10-4 Setting contents of master station parameters	10·13
Chapter 11: Error and Treatment	11·1
11-1 Indication lamp	11·1
11-2 Flag	11·2
11-3 Storage of error code	11·8

Chapter 12: Replacement of the JW-20MN	12·1
Chapter 13: Register and Load Parameters	13·1
Chapter 14: Specifications	14·1
14-1 General specifications 14·1	
14-2 Communication specifications 14·2	
Chapter 15: Appendix	15·1
15-1 Maintenance and check 15·1	
15-2 Recovery method at communication errors 15·2	
15-3 Table of parameter memory 15·6	
15-4 Address map of data memory 15·12	
15-5 Switch setting table 15·16	
15-6 Table for connecting cables and the connector parts 15·16	
15-7 Special functions unique to the JW-20MN 15·1	
Alphabetical Index	

Chapter 1: Outline

By installing this module in a programmable controller used to control a facility, you can configure an ME-NET system with various devices, such as personal computers and industrial robots, to create a factory automation (FA) system. Using this module, you can easily transmit and receive ON/OFF signals and data with other devices that have a network module compatible with the ME-NET specifications.

1-1 Example of system configuration

① Basic system

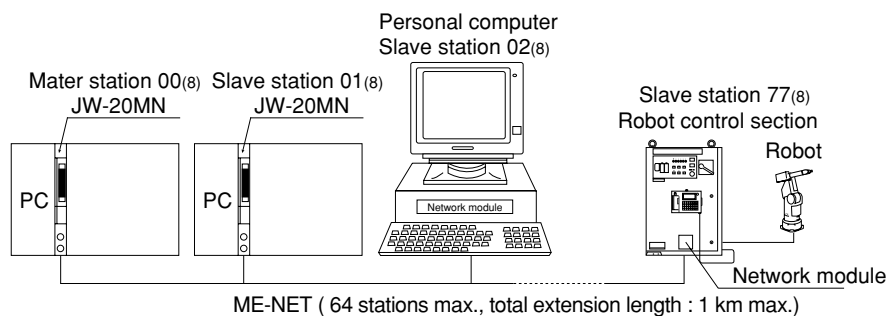

② Expansion system (extension of communication stations)

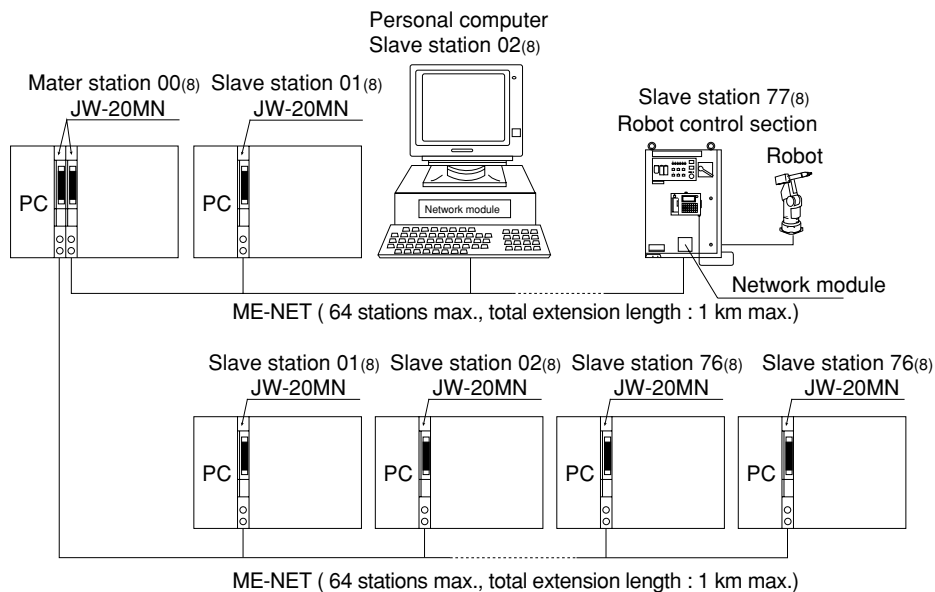

Reference

ME-NET is a communication network to link different brands of devices and equipment with different models of facility control equipment. It has been developed under the support of Toyota Motor Co., Ltd.

1-2 Function

(1) Data link function

- ① Send and receive an ON/OFF signal (relay link) and data (register link) between modules on the ME-NET.

Linkage method	Number of linkage points
Relay link	2048 (256 bytes) in total
Register link	2048 bytes in total

* The amount of data that can be transmitted and received by one station is a maximum of 1024 bytes, including both relay links and register links.

- V5 ② In order to use the memory effectively, the JW-20MN has a memory save function. When this function is enabled, it only needs to receive the specifically required data.
- ③ Since the JW-20MN manages the serial communications, no special program is needed to connect a PC.

(2) Computer link function

- ① Triggered on commands (instructions) from a host computer which has a network module compatible with the ME-NET specifications, the JW-20MN starts reading and writing the memory in the PC.
- ② After an instruction is received from the host computer, the JW-20MN returns a response. Therefore, the host computer needs an application program. For a detailed description of how to transmit instructions and receive responses, see the instruction manual for the host computer.

(3) The method is available for communication of up to 64 stations. By using a cable, it can be extended up to 1 km.

Chapter 2: Safety Precautions

2-1 Installation

- Do not install or store the JW-20MN in the following conditions.
 - Direct sunlight
 - Ambient temperature exceeding the range of 0 to 55 °C (Storage temperature : -20 to 70 °C)
 - The relative humidity exceeding the range of 35 to 90%.
 - Sudden temperature changes which may cause condensation.
 - Corrosive or inflammable gas
 - Vibration or hard jolts
- Prior to installing or detaching the JW-20MN, make sure to turn OFF the power supply to the JW-20MN.
- All screws must be tightened firmly.

2-2 Wiring

- Make sure to use only the recommended types (see page 6·1) for cables, connectors, and crimping tools. Cable and connector installation and changes must be performed only by specialists approved by the ME-NET bureau.
- When using connectors for branch or joint lines, provide jackets to protect connectors. (When a connector touches with an external enclosure or the like, a communication error may occur.)

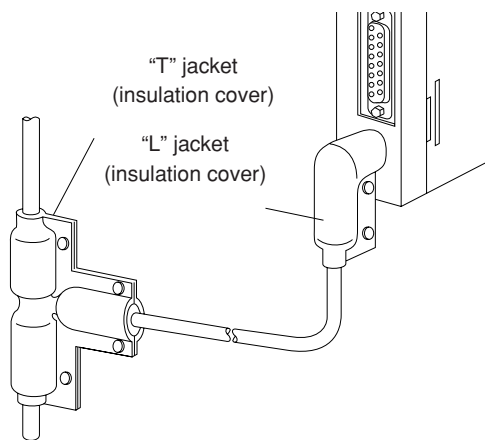

- Do not connect the ground terminal of the power supply module together with other equipment's ground lines. Make sure to provide class-3 grounding. When the JW-20MN is used without connecting a class-3 grounding, malfunctions by noise may occur.
- Communication cables should be arranged as far from any high voltage lines and strong power lines as possible. Do not lay the communication cable parallel or proximate to these lines.

- Communication cables should be laid from the master station to the slave station one by one. Multiple wiring from one point or wiring without terminators may cause communication errors.

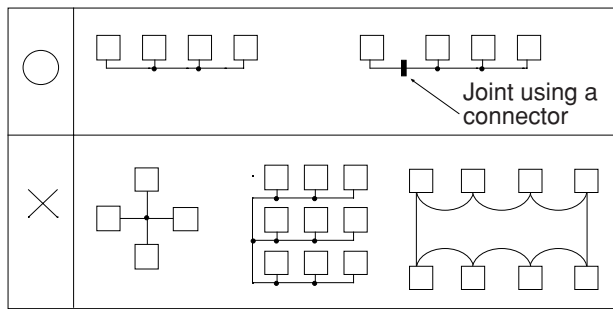

- Arrange total cable length within 1 km.
- Arrange branch cable line from a trunk within 400 mm.
- Prior to any electric welding around the JW-20MN, take out the coaxial cable from the JW-20MN. While the coaxial cable is connected to the JW-20MN, any electric welding nearby the JW-20MN will cause the welding current to enter the JW-20MN and may damage part of its circuit pattern.

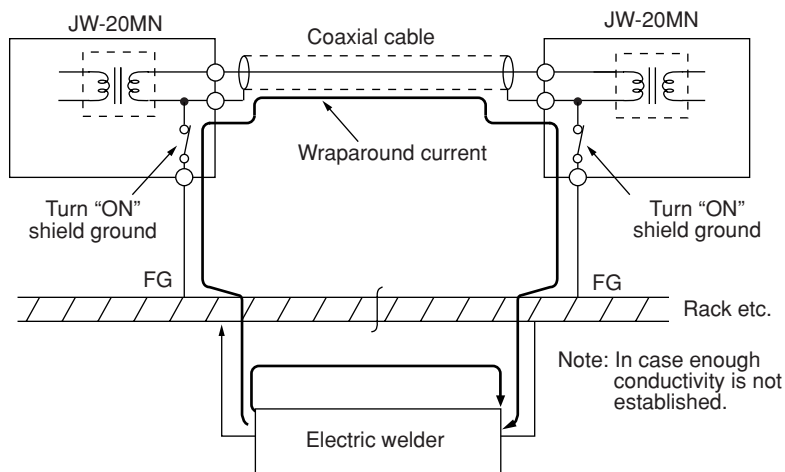

2-3 Treatment

- For ventilation, holes are provided in the cabinet to prevent a temperature rise. Do not block the ventilation holes. Good ventilation is necessary.
- Never allow a liquid such as water and chemical solution and a metallic object like a copper wire inside the JW-20MN to avoid a possible hazard. Otherwise, it may be a cause of machine trouble.
- When a trouble or abnormal condition such as overheat, fume, or smoke is met, stop the operation immediately, and call your dealer or our service department.

2-4 Static electricity

In extremely dry circumstances, the human body may have excessive static current. This excessive static current may damage parts in the JW-20MN's PC board. Therefore, prior to accessing the JW-20MN, touch your hand to a grounded piece of metal to discharge the static current in your body.

2-5 Cleaning

Use a clean, dry cloth when cleaning the JW-20MN. Do not use volatile chemicals such as thinner or alcohol as it may result in deformation and color fading.

Chapter 3: Name and Function of Each Part

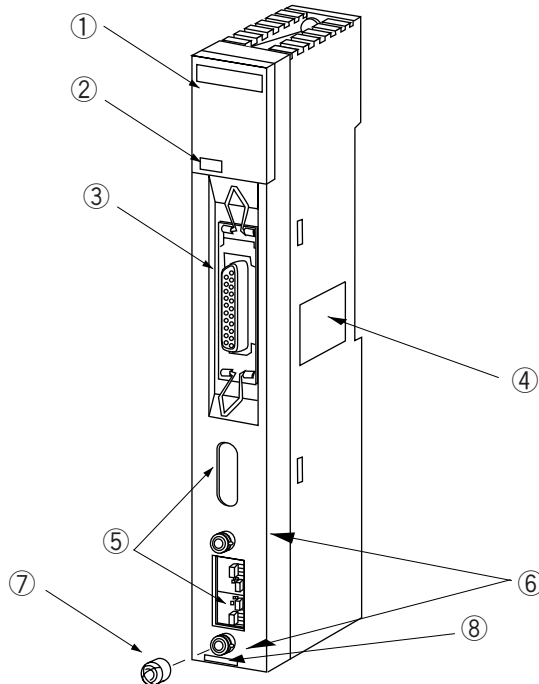

① Indicator lamps

Lamps light ON/OFF indicates operation condition.

ME-NET	
COMM	○ ○ S 0
SD	○ ○ S 1
RD	○ ○ S 2
CD	○ ○ S 3
LT	○ ○ S 4
TEST	○ ○ S 5
COM. E	○ ○ S 6
UNT. E	○ ○ S 7
30Hn	JW-20MN

Name	Operation
COMM	Lights when data link operating
SD	Blinks when data sending*
RD	Blinks when data receiving*
CD	Blinks when detecting carrier*
LT	Lights when turning ON the termination resistance
TEST	Lights during testing
COM.E	Lights when detecting error
UNT.M	Lights at time up of the watchdog timer (JW-20MN error)
S0 to S7	Lights error code when error occurs.

* "Flickering" means that the LED is flashing ON and OFF.

② 30Hn mark (applied to JW30H)

JW-20MNs having **30Hn** mark can communicate with JW30H.

JW-20MNs having **30H** can communicate with conventional modules of JW30H (JW-31CUH/32CUH/33CUH). However, when they will communicate with new modules of JW30H (JW-31CUH1/32CUH1/33CUH1/33CUH2/33CUH3), they recognizes these new modules as conventional modules.

- ③ A connector for support tool
Connects to various support tools for entering parameters.
- ④ Rating plate
- ⑤ Setting switch
Set functions of JW-20MN.

Set at delivery

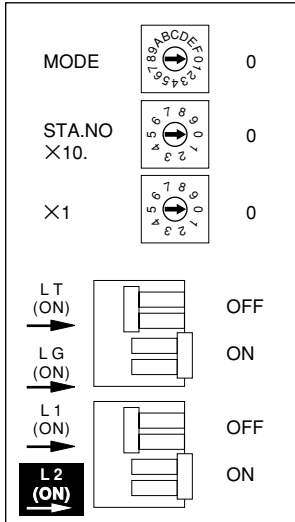

· MODE switch.....Select functions

Switch setting	Function
0	Don't set in this mode.
1	Don't set in this mode.
2	Data link (standard function)
	Computer link
3	Data link (memory capacity save function)
	Computer link
4 to F	Test mode A service man will use these switches for adjustment. Don't set in this mode.

*Be sure to set to "2" or "3."

- Station number switch (STA.NO. X 10, X 1)
..... Set the station address.
- Termination resistance (LT) Set ON/OFF of termination resistance
- Shield ground switch (LG) Set shield ground of communication cable
- Communication line 1 switch (L1) Set ON/OFF of communication line 1
- Communication line 1 switch (L2) Set ON/OFF of communication line 2

- ⑥ Connection connector
BNC type receptacle (jack)
L1: Communication line 1
L2: Communication line 2

- ⑦ Connector protective cap

- ⑧ Version label
Indicates the version of the communication board inside.

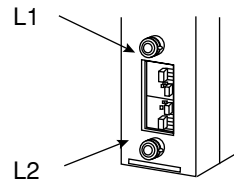

Chapter 4: Installation

4-1 Installation of cable for option module

Install the optional cable on the basic rack panel that installed JW-20MN.

PC module name		Basic rack panel model name	Cable for option module
ZW model	W70H	ZW-28KB	ZW-2CC
	W100H	ZW-46KB	ZW-2CC/4CC
JW model	JW50	ZW-28KB	ZW-2CC
	JW70	ZW-46KB	ZW-2CC/4CC
	JW100	JW-4BU	ZW-2CC
	JW50H	JW-6BU	ZW-2CC/4CC
	JW70H	JW-8BU	ZW-2CC/4CC/6CC
	JW100H	JW-13BU	ZW-2CC/4CC/6CC

[Example] When to install a basic rack panel JW-4BU to ZW-2CC

- ① Bend the optional cable

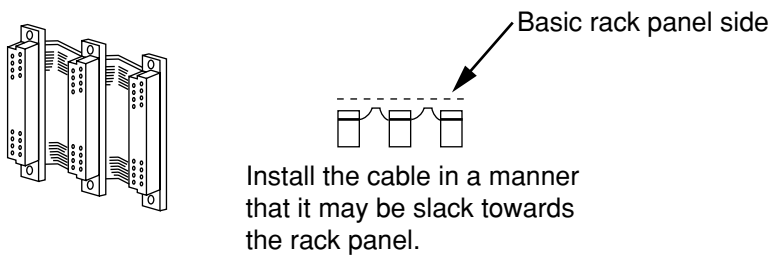

- ② Attach the connectors in the optional cable one after another, starting from the left side.

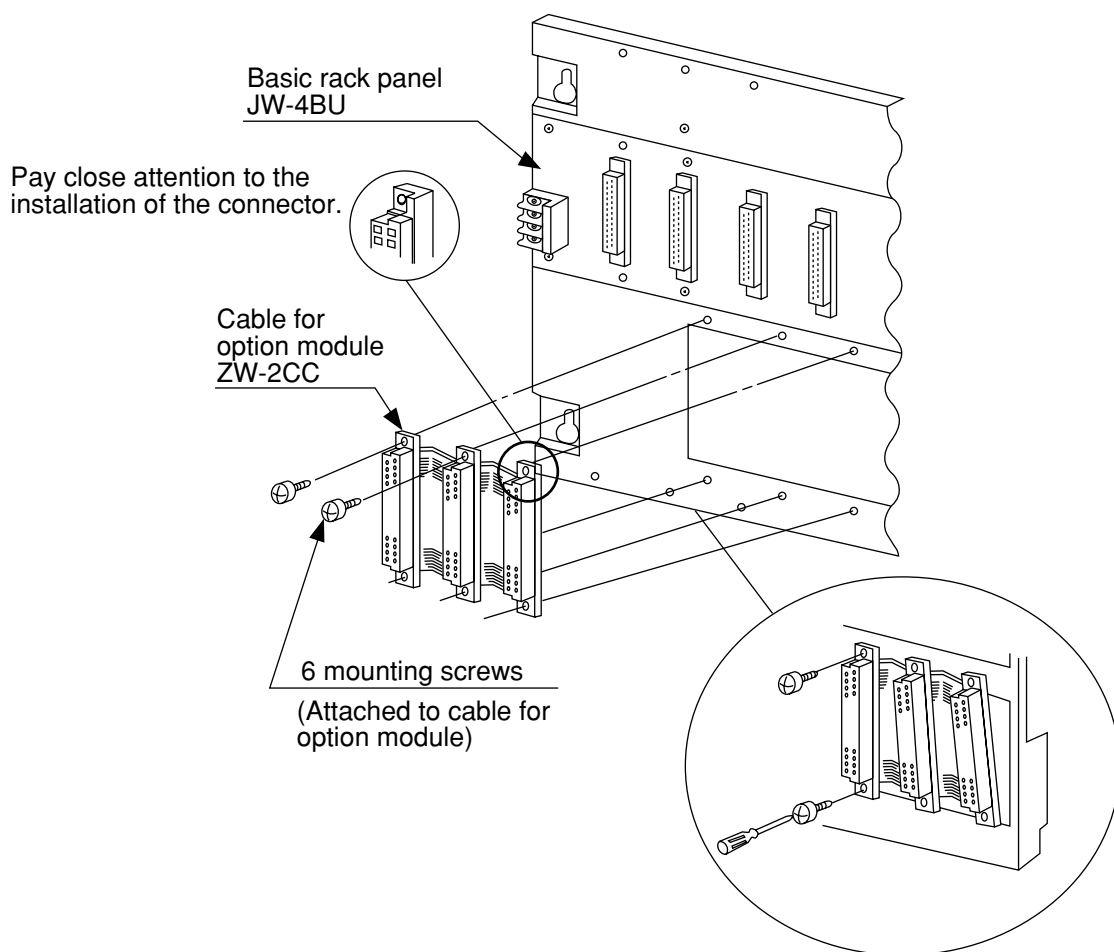

4-2 Installation of JW-20MN

Attach the basic rack panel using the two attachment screws.

Before installation or removal, make sure to shut OFF the power supply to the PC.

[Example] Install on basic rack panel JW-4BU

- This module can be inserted into any one of the optional slots.
- Be careful not to bend the connector pins on the module by applying too much force to them.

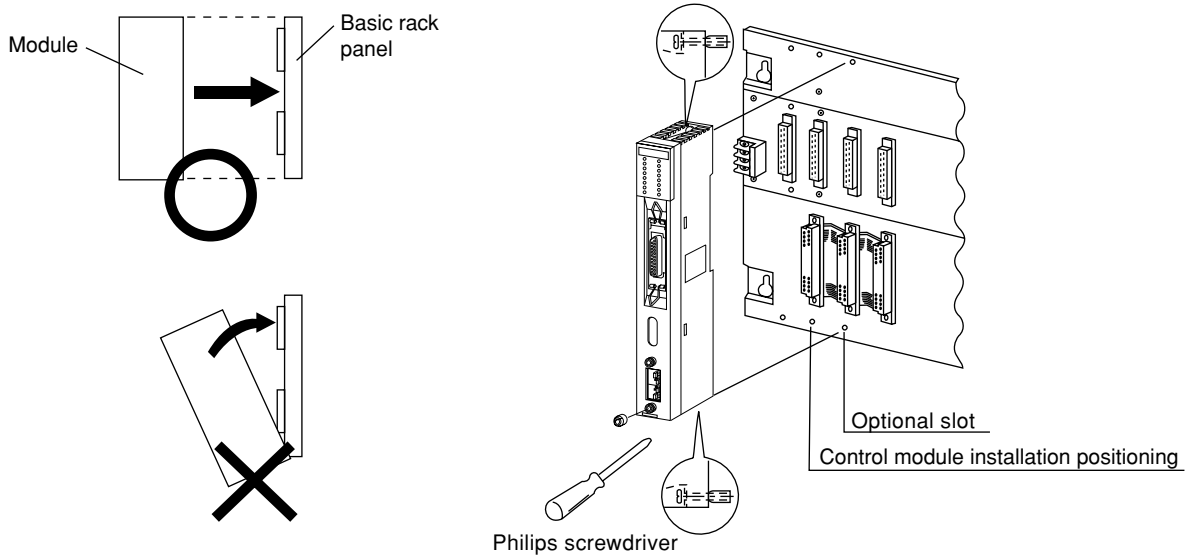

- More than one modules of JW-20MN can be installed on one basic rack panel. However they cannot communicate by crossing-over another network.

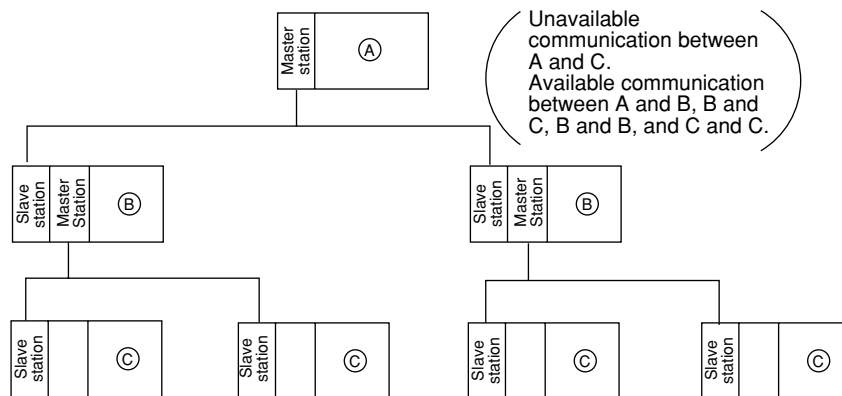



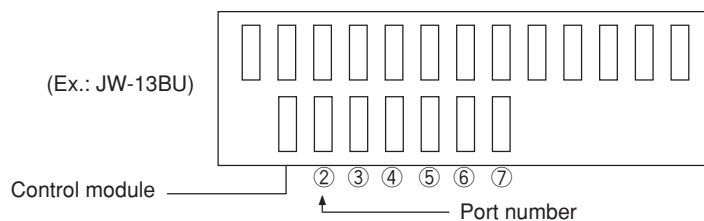

- Optional slots have each port numbers. When an error occurs, the JW-20MN stores the port number corresponding to the error occurred module into system memory #050 in the PC.

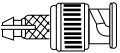
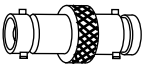

Chapter 5: Processing of Cables

Make sure to use the qualified products shown below for cables and connectors. Cable and connector installation and changes must be performed only by specialists approved by the ME-NET bureau.

Name		Model	Maker
Cable	High frequency coaxial cable	ME-5C-2V	Mitsubishi Cable Industries,. Ltd. Fujikura Cable,. Ltd. Furukawa Denko Corporation Chugoku Cable,. Ltd. Shinagawa Cable,. Ltd.
Crimping tools		ME-42H Dice: 67-42H	Toko Denshi Corporation
Stripper for high frequency coaxial cable		CST-TM (The system consists of the main body, a blade cassette, and a blade setting gauge)	Nihon Weidmüller Co., Ltd.
Jacket	"L" jacket	SB-2878	Shinagawa Shoko Co., Ltd.
	"T" jacket	SB-2879	
Insulation tape	Self-adhesive tape	NO.11	Nitto Denko Corporation
Connectors	Connector 	ME-GP-01	Toko Denshi Corporation DDK Ltd.
	Straight 	ME-JJ-01	
	Elbow 	ME-LA-01	
	T's 	ME-TA-01	
	Termination 	ME-75	

5-1 Processing cable end

① Applicable cable

High frequency coaxial cable: ME-5C-2V

② Required tools

Stripper for high frequency coaxial cable: CST-TM

③ Processing procedure

<Basic operation>

Move the cam wheel of the stripper (amber colored ring) back and forth and the cable holder moves back and forth accordingly. Confirm this movement of the stripper first.

To hold the stripper, put your forefinger through the hole and move the cam while pushing back and forth with your thumb.

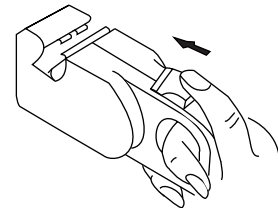
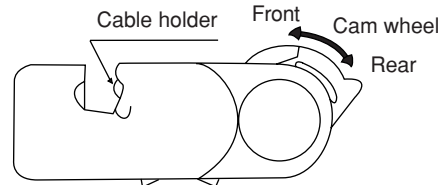

<Pressure setting>

Set the operation range of the cable holder by moving the slider at the bottom of the body. Move to the left to increase pressure.

In this example, set the slider to the cam wheel side's end (right side) to set the pressure to low.

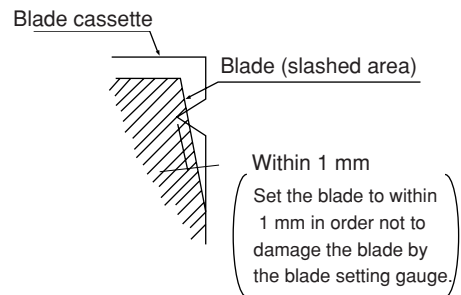

<Adjustment of blade cutting depth>

Adjust the cutting depth of the blade by turning the two screws at both ends of the screw holder. Set the blade position to within 1 mm from the cutting surface of the blade cassette prior to adjusting the cutting depth. For the cutting depth adjustment, use the "blade setting gauge" supplied as an accessory and match the blade position with the caved position of the gauge. Then move the cam wheel forward and secure firmly. Turn right lightly both adjustment screws at either end of the screw holder for adjustment. (Be careful not to break the blade setting gauge as it is made of aluminum.)

(Fine adjustment is required to get the optimum cutting depth.)

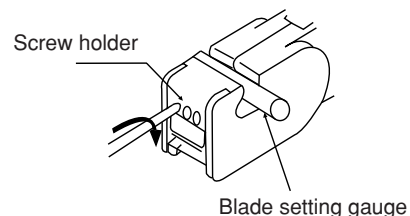
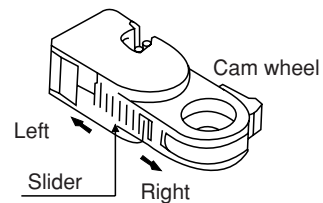

To the next page

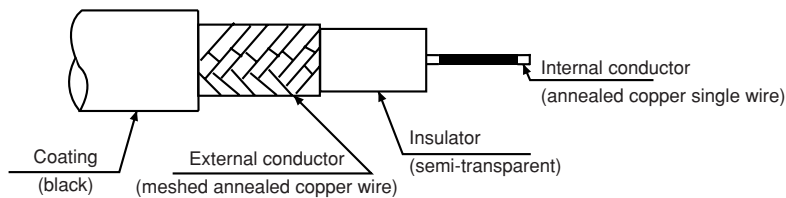

From the previous page

<Cutting of coating, external conductor, and insulator>

Put a coaxial cable while remaining approximately 10 mm into the cable stripper and securely tighten the cable with the middle finger, ring finger, and little finger of your left hand in order to hold stable during turning the stripper. Put your right hand forefinger into the cam wheel and execute the procedure in order from step 1 below.

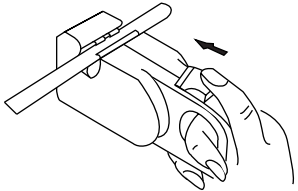

- Step 1** Press the cam wheel forward 3 times and turn the stripper in the direction of arrow 2 to 3 times.
- Step 2** Press the cam wheel forward 1 time and then turn the stripper in the direction of arrow a further 2 to 3 times.
- Step 3** Press the cam wheel forward 1 more time and turn the stripper in the direction of the arrow another 2 to 3 times.

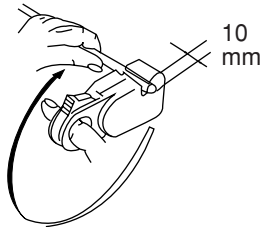

<Removal of coating, external conductor, and insulator>

While holding the coaxial cable with your left hand, grip the cable stripper so that it keeps a right angle against the coaxial cable, and press out the cable stripper with your left hand's thumb.

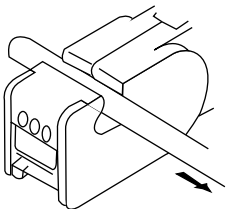

When the adjustment of the blade is not required

If the stripper cannot be removed smoothly, adjustment of the blade is not appropriate. In this case slide the cam wheel backward and remove the coaxial cable. Then adjust the blade.

<Fine adjustment of blade cutting depth>

When the cutting depth is too shallow or too deep, and damages the external conductor or the internal conductor, turn the screws on the screw holder and adjust the blade depth a little.

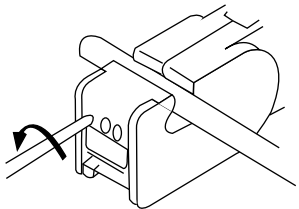

To the next page

From the previous page

<Display of blade setting>

We recommend that in order to keep the adjusted position of the adjustment screws, after completion of adjustment for the coaxial cable and the screw holder, write the screw position etc. on a sticker and adhere it to the adjustment screws.

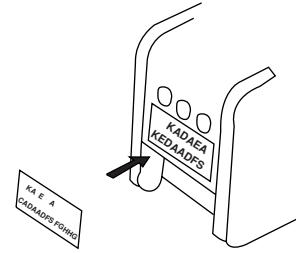

<Replacement of blades>

Hold up the upper section of the screw holder with a minus driver, and open the screw holder. Remove the blade cassette and reinsert by turning the current blade back side front or insert a new blade cassette from its top.

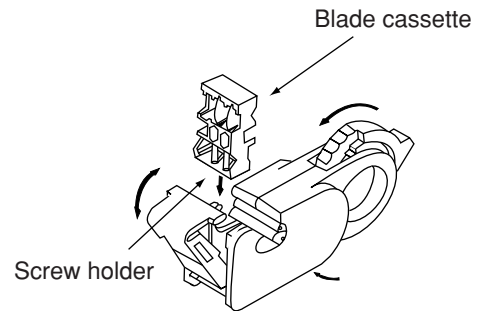

<Processing of cable end>

Cut the internal conductor of the coaxial cable, which is already cut by the stripper, using a nipper etc. to the optimum dimension of 4 mm.

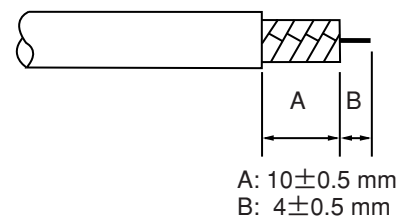
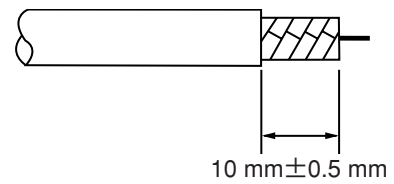

5-2 Connector crimping procedure

① Required tools: Hand-held crimping tool

Model	: ME-42H
Dice No.	: 67-42H
Crimping width	: 10 mm

Connector parts

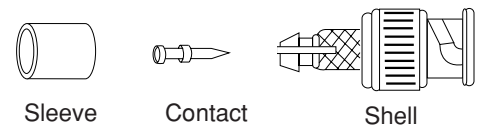

② Connector: ME-GP-01

③ Processing procedure

<Insert a sleeve>

Put through a sleeve to an end-processed high frequency coaxial cable.

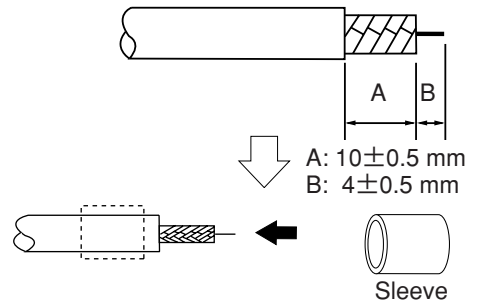

<Crimping contact>

Insert a contact into the internal conductor and crimp.

Put a contact into dice having a diamond shape and closely stick its end surface with the insulator and the dice. Pull the moving frame to the fixing frame side and crimp until the ratchet is removed.
(Crimping width: 2.2 mm)

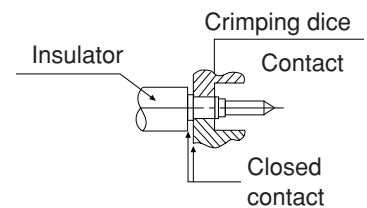
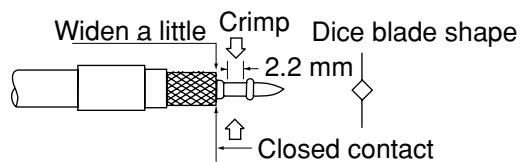
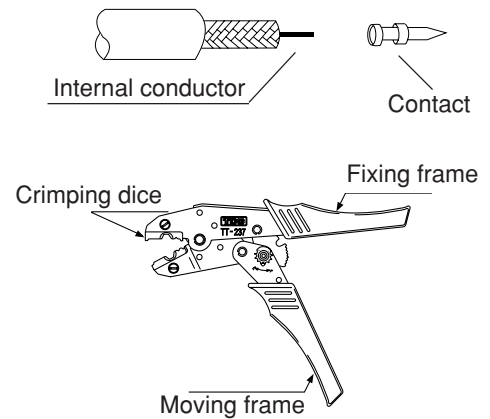

* Use the crimping tool in the direction shown in the illustration right. Using the crimping tool in the reverse direction will not crimp correctly.

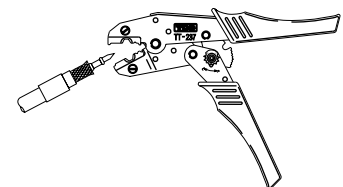

To the next page

From the previous page

<Fixing the connector>

Slightly widen the external conductor of the coaxial cable, which is crimped to a contact on the internal conductor, in order to smoothly enter the shell inside the external conductor. Press in the external conductor end of the coaxial cable to just before the crimping part of the shell and put the sleeve into the crimping section. Then press in the coaxial cable until a "click" sound can be heard. Confirm that the contact end point touches your finger cushion.

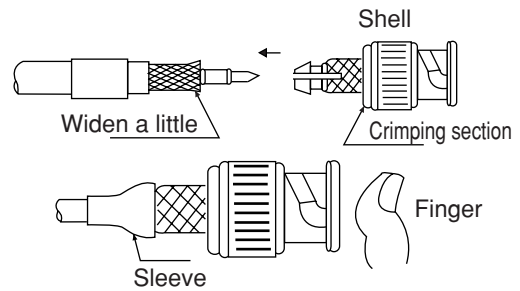

<Crimping external conductor>

Crimp the external conductor.

Insert thoroughly the sleeve into the crimping section of the shell and crimp. Put the sleeve in the hexagonal dice and closely stick the shell to the crimping dice. Pull the moving frame to the fixing frame side while pressing the coaxial cable and shell from both sides, and crimp until the ratchet is removed. (Crimping width: 10 mm)

Completely put into the crimping section.

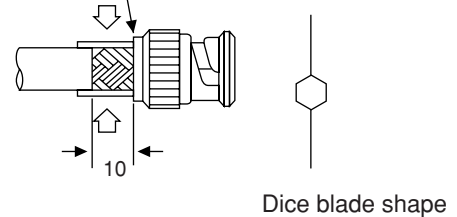

* Use the crimping tool in the direction shown in the illustration right. Using the crimping tool in the reverse direction will not crimp correctly.

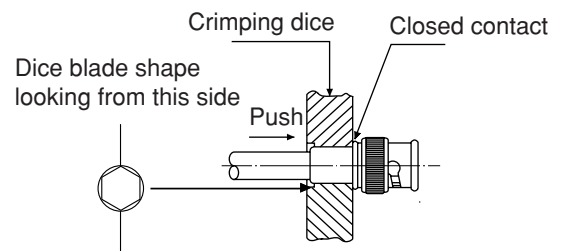

<Insulation test>

Insulation test of shell and contact

Using a tester, check the conductivity between the internal conductor and the external conductor in the connector. When the indication of the tester shows ∞ ohms, the insulation is appropriate.

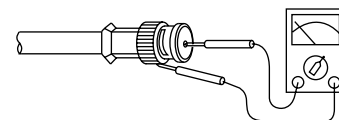
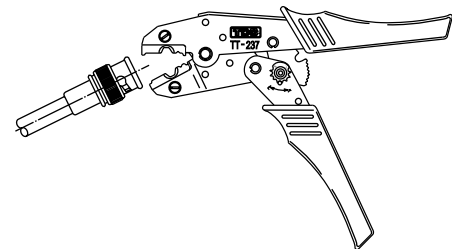

<Conductivity test>

Conductivity test

After short-circuiting the one end of the connector crimped to the coaxial cable, check that conductivity is attained.

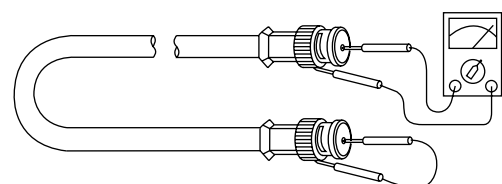

Chapter 6: Wiring

6-1 Cable trunk and branch lines

- ① On the illustration of the cable wiring below, a bold line means a trunk and the thin lines branched from the trunk with a “T” shape are called branch lines.

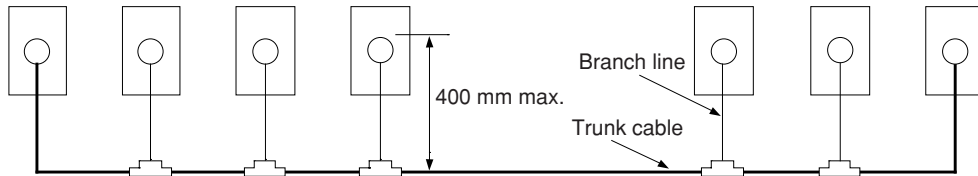

- ② The length of branch lines branched from the trunk should be within 400 mm.

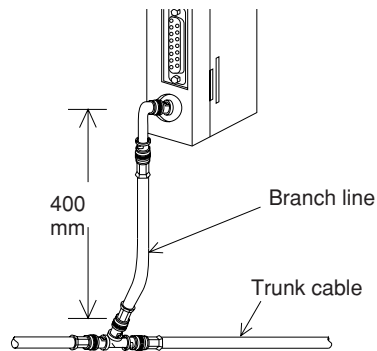

- ③ Total cable length should be within 1 km.

6-2 Relaying of trunk cables

- ① To relay trunk cables, use the straight joint (ME-JJ-01).

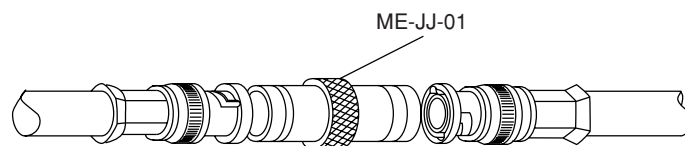

- ② Relaying of trunk cables should be limited to indispensable cases only. Inadvertent relaying of trunk cables may cause a communication fault such as a weakened signal level due to contact resistance in the junction connector (straight).

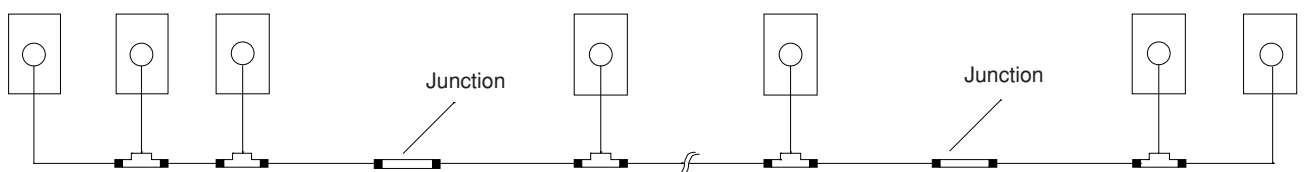

6-3 Cable wiring procedure in control panel

[1] Fixing of the cable

In order not to put any force on the cable and the JW-20MN, fasten the cable to a line nearby input of a control panel or a "T" branch point to the JW-20MN using saddles etc.

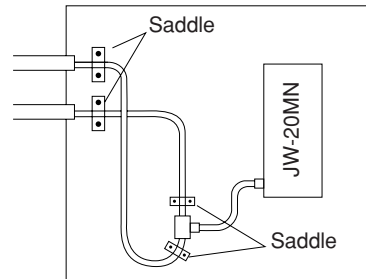

[2] Extra length of cable

Provide an extra length of the cable of 2 to 3 m inside a control panel for easier processing of the cable end and easier wiring when changing module positions.

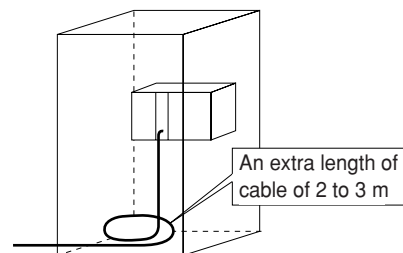

[3] Connection to the JW-20MN

The connector to the JW-20MN should be turned right to secure locking, not merely inserted.

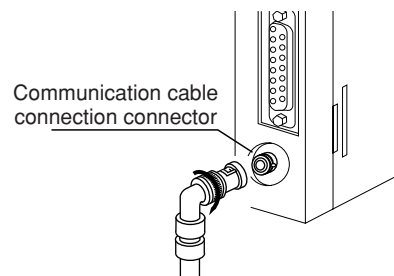

[4] Insulation cover

When the connector touches with a high voltage section or external enclosures, communication errors may occur. Make sure to install an insulation cover.

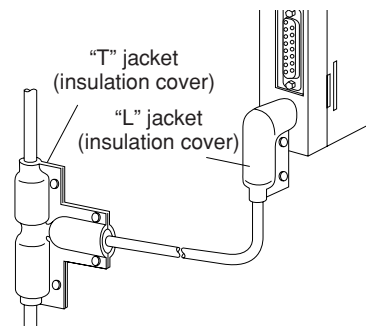

[5] Grounding of power supply module (JW-1PU etc.)

Make sure to connect the GND terminal of the power supply module using the ME-NET and the like to a class-3 grounding.

- If the power supply module is not grounded, the JW-20MN cannot conduct with the ground after turning "ON" the shield ground switch (LG).

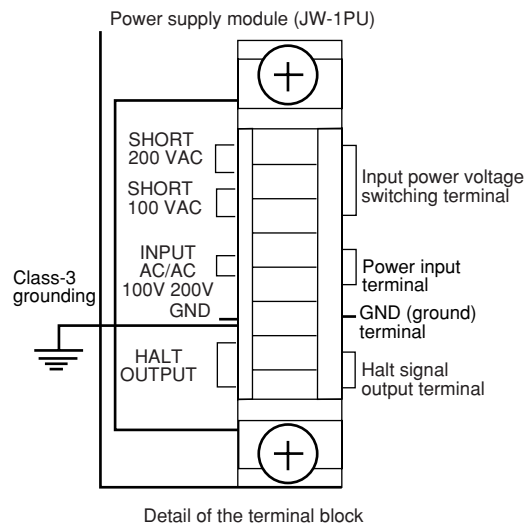

In case of AC power supply module (JW-1PU)

6-4 Waterproof and insulation processing of connectors

In order to prevent water intrusion into the “T” branch connectors and the straight connectors, we recommend to wind a self-adhesive tape and provide waterproof processing for them. For insulation purposes, cover these connectors with jackets.

[1] “T” branch connector

To wind a self-adhesive tape, cut the tape at about 10 cm each and start winding from position ①. Start winding cut tapes from ② and ③ as well.

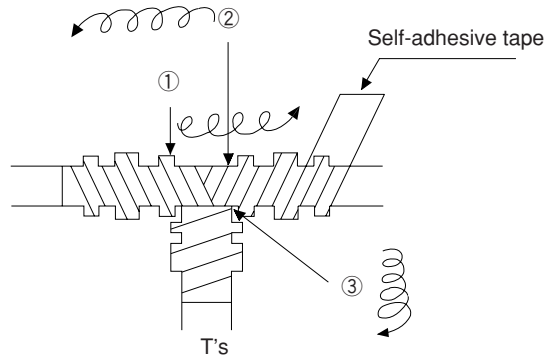

[2] Straight connector

To wind the self-adhesive tape, cut the tape at about 15 cm each and start winding from position ①.

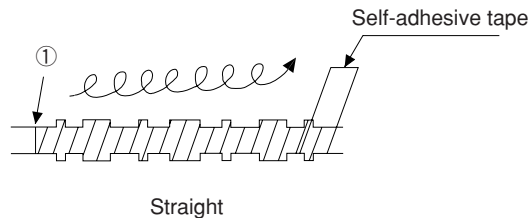

Remarks

Prior to adhering the tape, clean the surface of the connectors and stick the adhesive side of the tape on the connector surface. Wind to lightly spread on the connector surface, and overlap with the next wrap to half of the tape width. Wind the tape for each wrap evenly so that the connector metal portion is completely covered with the tape. Be careful not to excessively stretch the tape.

6-5 Wiring of cables at outside control panels

- ① Do not bundle the coaxial cable (the trunk and branch lines) together with power cables, and separate from power cables at least by 100 mm. Do not put the coaxial cable into a power line wired duct. The best way is to put the communication line in an independent duct.
- ② Be careful that the coaxial cable does not receive any load by laying under a heavy weight such as other cables.
When other cables run in the same duct as the coaxial cable, run the coaxial cable on the top position.
- ③ Do not run the coaxial cable outdoors as it may cause damage to the JW-20MN due to inductive lightning or atmospheric charge during lightning.

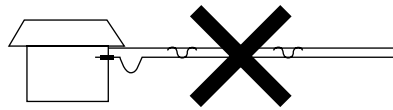

6-6 Check after wiring

Check the items below after completion of wiring.

	Check contents
1	The ME-NET qualified connector types are used.
2	The connectors are securely locked.
3	The connectors are insulated by T jacket or L jacket.
4	The ME-NET qualified coaxial cable type is used.
5	Curved radius of the coaxial cables are more than 45 mm.
6	No heavy load is on the coaxial cables.
7	The coaxial cable is not bundled with a power line cable. (Away from power line cables more than 100 mm.)
8	Length of branch lines is shorter than 400 mm.
9	Total length of the cable is less than 1 km.
10	Settings of the termination resistance switch and the shield ground switch are as per the drawings.

6-7 Wiring method for adding a communication station

[1] Branching method

When branching a line for an additional station, be sure to branch from the trunk using a T connector. Never branch from a branch line.

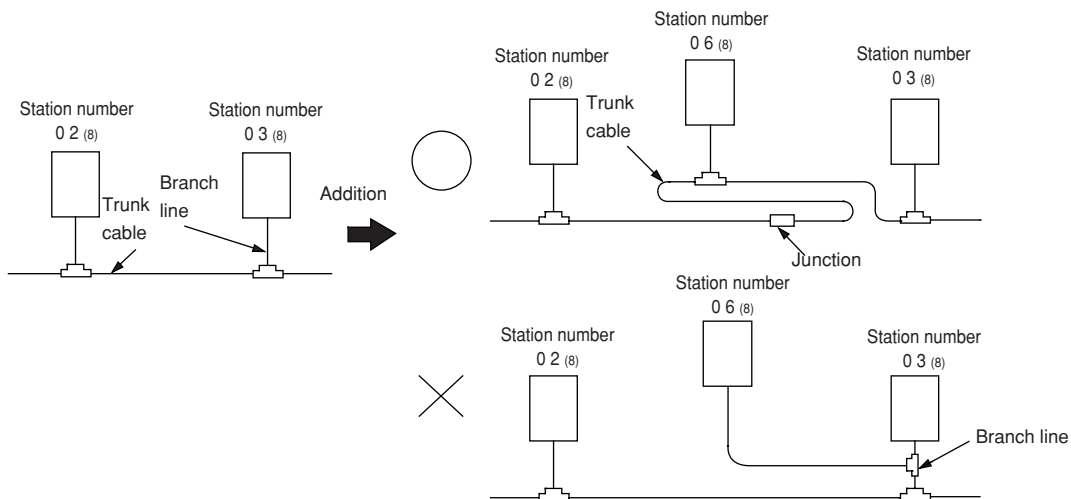

[2] Station number of the additional station

Station number of the newly added station should be next largest number from the current largest numbered station. Each station should not be required to be arranged in order of each station's number.

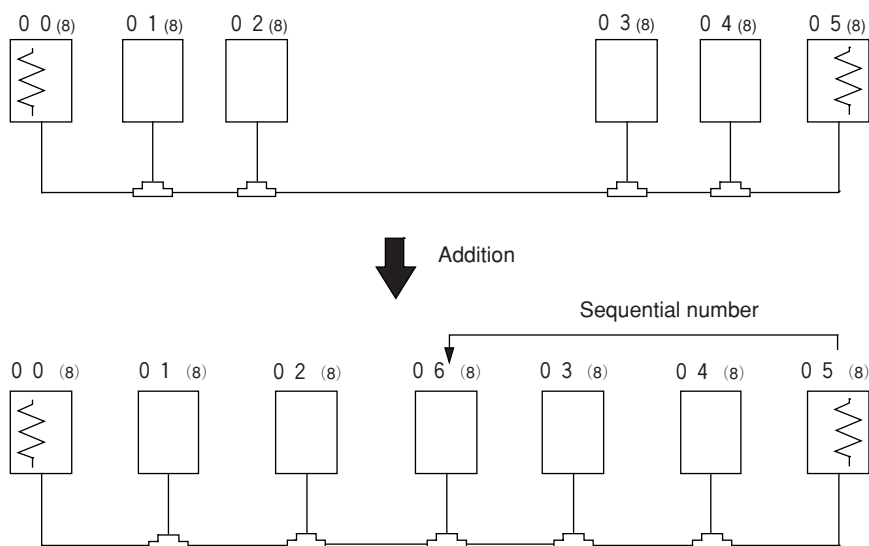

⚡ means the LT (termination resistance) being turned "ON."

[3] Notes

When adding a communication station, follow the items below.

No.	Item	Reason
1	Branch from the trunk cable.	Another branch line from a branch line may not give appropriate communication by reflection wave.
2	Don't use the same station number twice.	The use of the same station number twice may cause communication errors.
3	Check the termination resistance switch.	When the newly added station becomes a termination of the circuit, change the setting of the LT switch.
4	Provide extra length for the expansion cable.	Have enough cable length in order to provide easy wiring.
5	Do not exceed the 1 km limit for total length of the cable.	Longer wiring may cause communication error by signal attenuation.
6	Change the layout drawing for installation.	Maintain the added work data for future maintenance use.
7	Do not overlap with any PC's communication area.	When the communication area or the flag area of the added station overlaps with other addresses in use, communication errors may occur.
8	Set the parameter memory of the master station and that of the newly added station.	Without setting the parameter memory of the master station and that of the slave station, the added station cannot communicate.

Chapter 7: Memory Addresses on the ME-NET

The ME-NET employs a system for addressing individual memory banks in all of the connected equipment by allocating address throughout the ME-NET. Therefore, the top address in any link area which will contain in the data link parameters and memory addresses used for computer link instructions must be a valid memory address in the ME-NET.

The relationship between memory addresses in Sharp PCs and those on the ME-NET are shown below. For details, see “15-4 Data memory address map” on pages 15-11 to 15-14.

7-1 Memory address for data links (link area top address, flag top address)

The memory addresses on the ME-NET correspond to the file addresses ₍₈₎ in a Sharp PC.

File address		Byte address	File address		Byte address
000000	Input/output relay	30000	004000	Register	09000
000377		30377	004777		09777
000400		30400	005000	19000	
000677	Auxiliary relay	30677	Register	19777	
000700	Latch relay	30700			
000777	General-purpose relay	30777	005777	19777	
001000		31000	006000	29000	
001577	TMR·CNT timed contact	31577	Register	99000	
001600		b0000			
001777		TMR·CNT·MD current value			b1777
002000	015000		99777		
003777			015777		

Enter a byte address at a file address in file number 0.

For file numbers 1 to 7, enter both a file number and a file address.

7-2 Memory addresses for computer links

- Data memory byte addresses in the computer link must be entered the same way a data link address is entered.
- The relay numbers are the same for the ME-NET.
- Program addresses 000000₍₈₎ to 076777₍₈₎ correspond to addresses 000000₍₈₎ to 076777₍₈₎ in file (segment) 8. Program addresses 100000₍₈₎ to 176777₍₈₎ correspond to addresses 000000₍₈₎ to 076777₍₈₎ in file (segment) 9.

For details about the absolute addresses to use on the host computer, see the instruction manual for the host computer.

Chapter 8: Description of the Data Link Operation

The data link function communicates data by using one PC module or FA device on the ME-NET as a master station. All other devices are slave stations. A maximum of 64 PCs and FA devices can be connected on a single ME-NET. The amount of data that each station can transfer is a maximum of 1024 bytes.

Each station must have an area used exclusively for its data link. This area is divided into the number of stations connected.

Each station will transmit the data in its sending area in turn. It stores the data received from other stations in its receive area.

This communication does not need any PC special program since the JW-20MN automatically manages communications.

The data link consists of the relay link and the register link. Both links can be used at the same time.

8-1 Communication method

The link area, top address, number of bytes to send, and the number of stations connected are sent to the master station and slave stations as data link parameters.

[1] Data link (standard function)

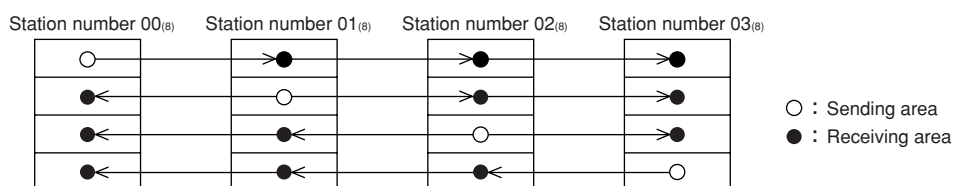

Function	Contents	
Relay link	N: M communication	Total No. of link points : 2048 max. (256 bytes)
Register link	N: M communication	Total No. of link bytes : 2048 max.

(1) Relay link

Mainly used for sending and receiving ON/OFF information.

[Example] In the case of sending 1-byte data from a master station and slave stations 01 and 02.

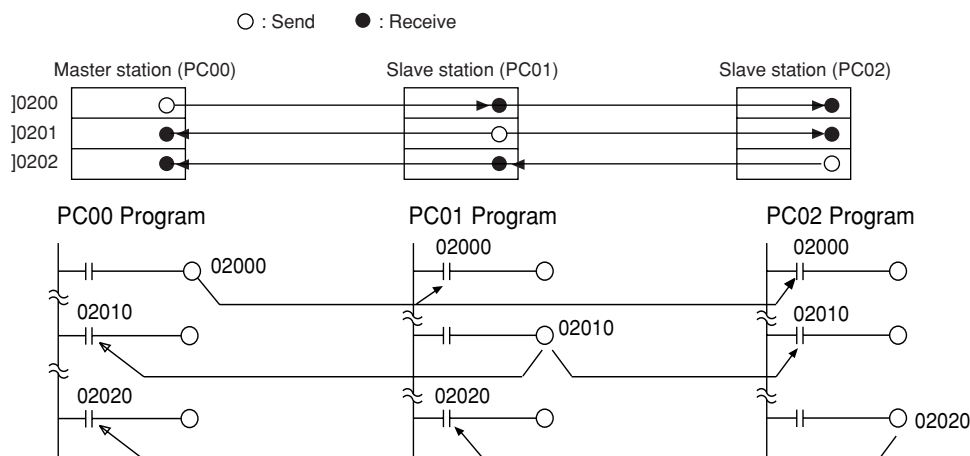

- The link relay of the receiving station must be programmed as input signal by the PC programming. Also, it may be used as source (S) side of application instruction.
- The sending and receiving data correspond in bits of one point unit.

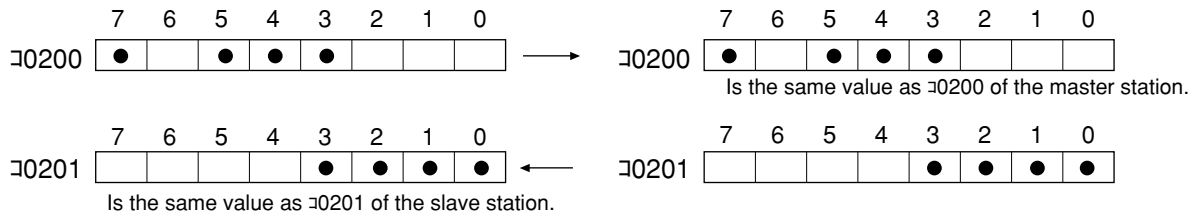

(2) Register link function

Mainly used for sending and receiving numerical data.

[Example] In the case of sending 1 byte data from a master station and slave station 01 and 02.

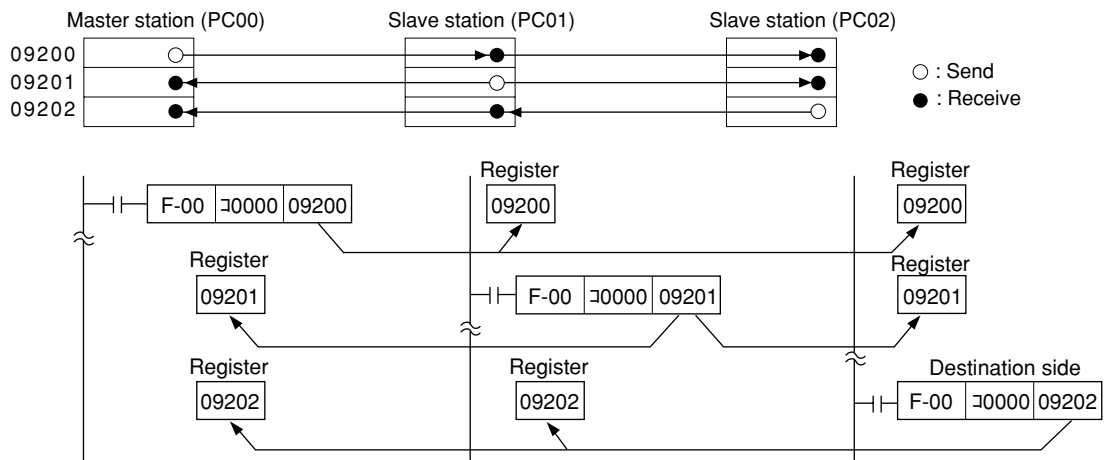

- The register link area of the sending station may be used as D (Destination) side of the application instruction of the PC program.
- The register link area of the receiving station may be used as S (Source) side of the application instruction of the PC program.

(3) To connect a slave station which has limited data link area

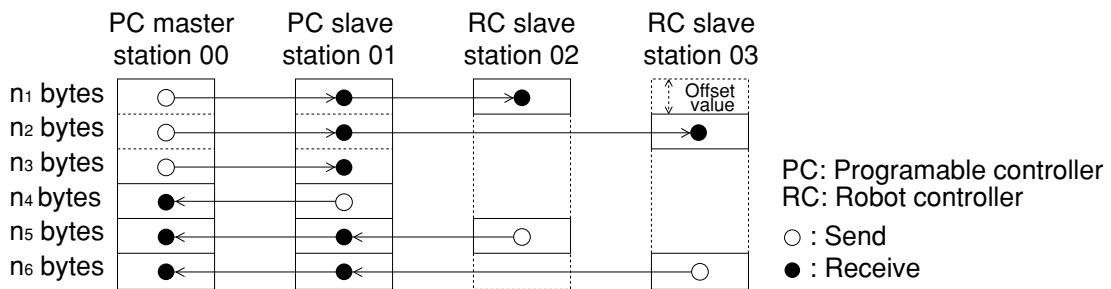

- Slave stations 02 and 03 only receive data sent from the master station. Enter the offset value for the area of the master station from which the slave stations will receive data.
- In the case of the figure above, slave station 02 receives data from the top of the data sent from the master station. Therefore, the offset value should be "0 bytes." In the same manner, the offset value for slave station 03 should be "n₁ bytes."
- Enter the offset value for each slave station in the registers of slave station links top addresses inside the master station. Enter a different value for each slave station.
- For details about the offset value, see the instruction manual for each device. When the JW-20MN "memory capacity save function" is enabled, the offset value must be set. For details, see the next page.

V5 [2] Data link (Memory capacity save function)

The memory capacity save function is to provide a part of the data link area in the slave station data memory as a receiving area. A slave station can receive only the required area by relay link/register link so that the slave stations can save on use of the memory area.

As this function can unify the receiving area address and the sending area address of each slave station, the same program can be used for each slave station. Mixed allocation of the addresses with the data link (standard function) is also possible.

To specify top address of the data receive area in a slave station, enter number of offset bytes from the top of the link area

(0 ≤ number of offset bytes ≤ total number of bytes of the link area)

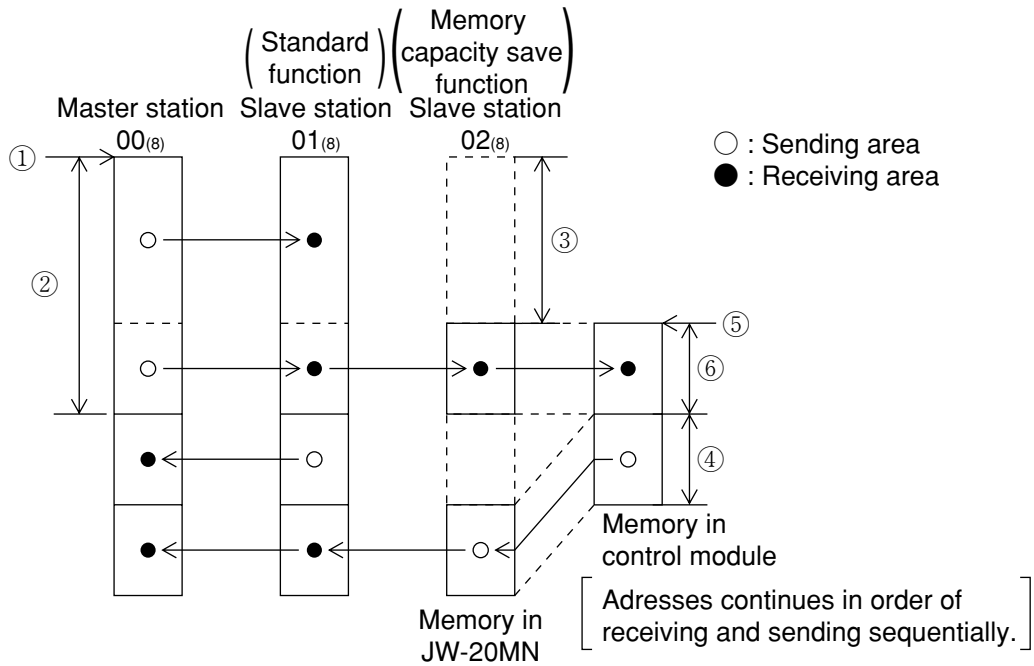

Function	Contents	
Relay link	N: M communication	Total link number of points: Maximum 2048 points (256 bytes) Total number of points of sending/receiving data per slave station: Maximum 512 points (64 bytes)
Register link	N: M communication	Total link number of points: Maximum 2048 bytes Total number of points of sending/receiving data per slave station: Maximum 512 bytes

Setting contents	Setting item
① Top address of master station link area	Master station 's parameter
② Number of sending data bytes of master station	
③ Number of offset bytes of slave station	
④ Number of sending data bytes of slave station	
⑤ Top address of slave station link area	Slave station's parameter
⑥ Number of data receiving bytes of slave station	

8-2 Data transfer required time and communication delay time

(1) Required time for data transfer

This is the time required for the master station to complete communication with all stations, and is determined by the number of connected stations with and the number of data items to transmit.

$$\text{Transmission T operation cycle} = \frac{N + 136 \times P}{1250} + 2.5 \times P + \alpha + 16 \text{ (ms)}$$

N : Total number of link points (value to be calculated by relay link bytes and register link bytes 8 points).

P : Number of connected stations (master + slave)

136 : 136 bits are used for station address and error check data on the communication format.

1250 : Transfer speed: 1.25M bits per second

2.5 : Inter-station wait time plus processing time to move to next station (unit : ms)

α : Communication recovery operation time

• When an error occurs at any station, the master station periodically treats the error.

$\alpha = 3.5 \times \text{number of error stations ms}$

16 : Time to maintain token bus. It can enter at random intervals.

[Example] In the case of two connected stations and 8 bytes of link points,

$$\begin{aligned} \text{Transmission T operation cycle} &= \frac{8 \text{ bytes} \times 8 \text{ points} \times 2 \text{ stations} + 136 \times 2 \text{ stations}}{1250} \\ &+ 2.5 \times 2 \text{ stations} + 16 = 21.32 \text{ ms} \end{aligned}$$

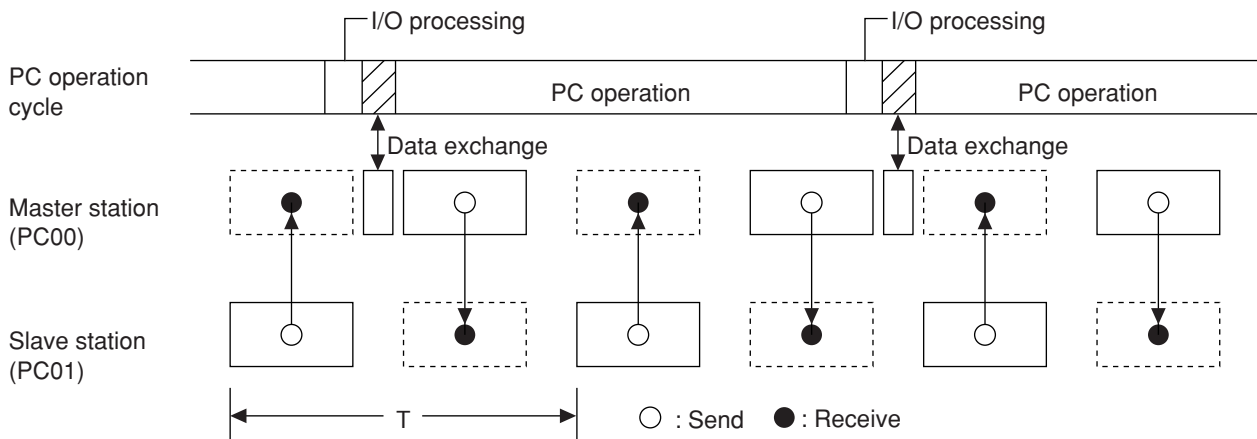

(2) Communication delay time

The communication data on the ME-NET may have the delay shown below.

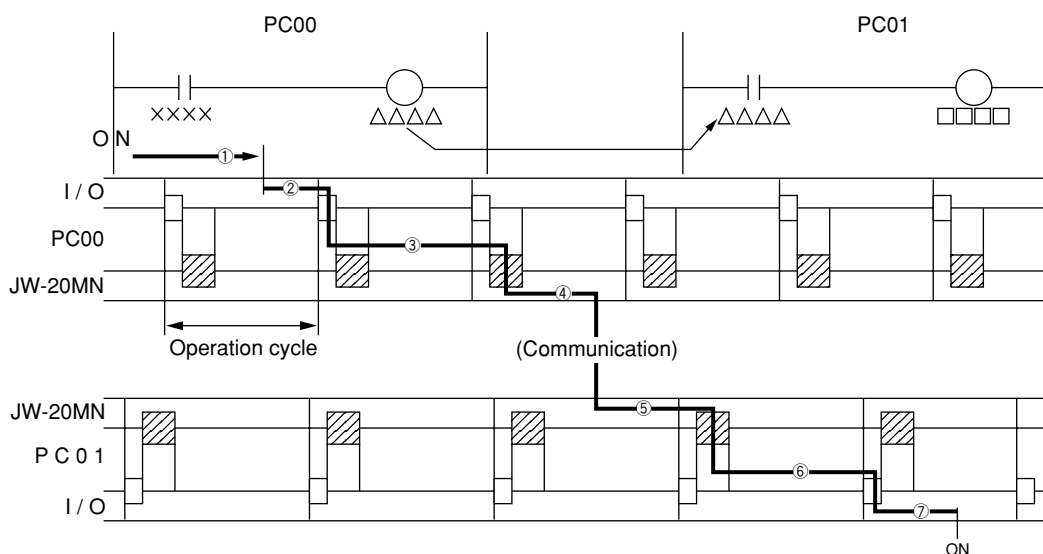

- ① Delay of input module
- ② Time required for PC to detect input state (one operation cycle max.)
- ③ Operation time of sending PC (one operation cycle)
- ④ Time to complete sending of operation result (one communication cycle max.)
- ⑤ Time required for receiving PC to write receive data in PC data memory (one operation cycle max.)
- ⑥ Operation time of receiving PC (one operation cycle)
- ⑦ Delay of output module

Communication delay time is the total time of ① to ⑦ above.

Remarks

The buffer memory contents of the JW-20MN is renewed for each PC operation cycle. Therefore, a contact point which turns "ON" for only one operation cycle of a PC may not be transferred.

(3) Data transmission between master PC and slave PC

Providing synchronous transfer gives positive data communication.

[An example of synchronized transfer by OUT instruction]

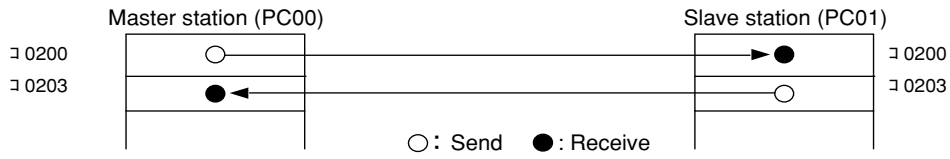

Program in master station

Program in slave station

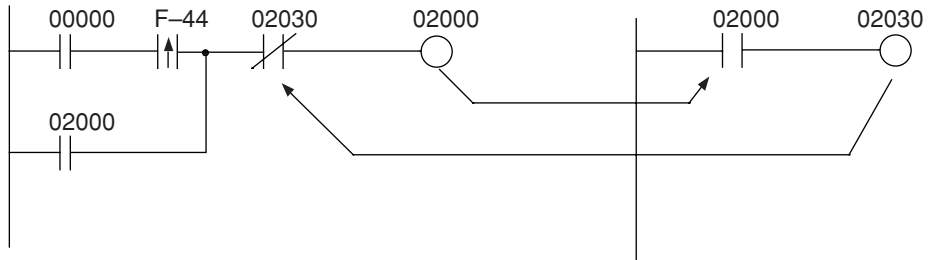

- 00000 is turned "ON" at the master station side. (OUT 02000 is a self-latch circuit.)
- When 02000 is turned "ON" at the slave station side, OUT 02030 is also turned "ON." This is sent back to the master station side.

8-3 Expansion of network

The JW-20MN can transmit data between 64 stations at maximum. If more than 64 stations are required for data link, you can add communication stations with the procedure below.

(1) Multiple installation of the JW-20MN

Mounting more than one JW-20MN on the optional slot of the basic rack panel can increase the number of stations.

[In the case of mounting 4 sets of JW-20MN]

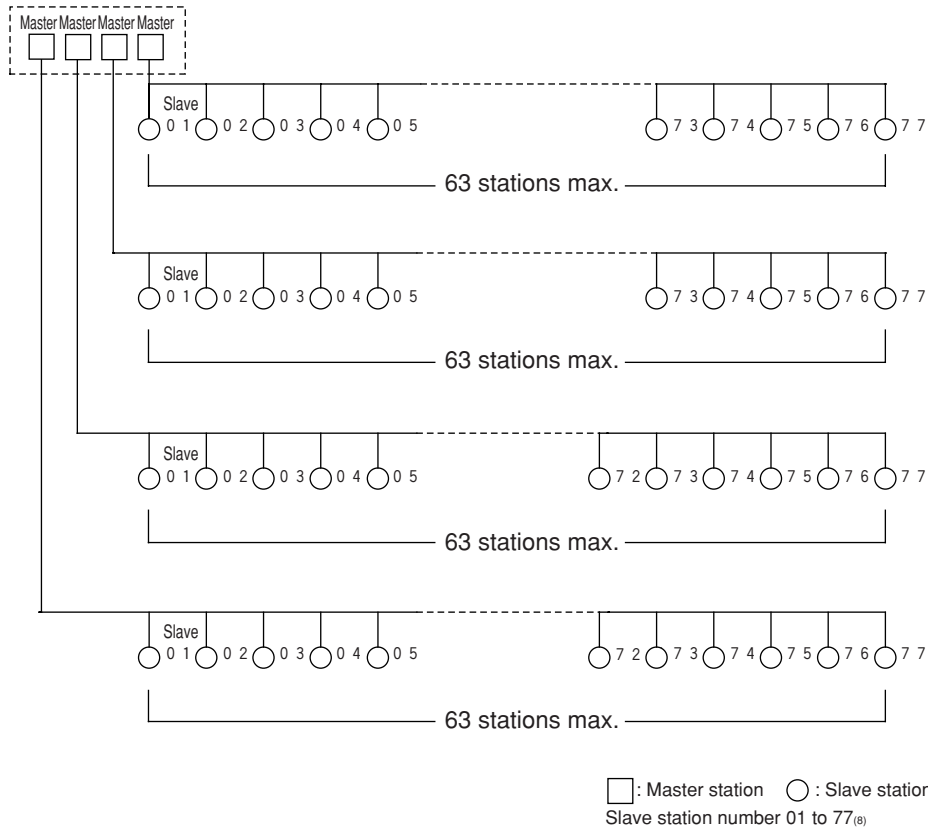

Remarks

- When installing multiple number of modules on a single PC, make them allocated so that relay link area, register link area, and flag area may not overlap with each other.
- When installing multiple number of modules on a single PC, pay attention to the total communication data volume and the number of bytes available for communication area.
- Though more than one JW-20MN can be mounted on single basic rack panel, they cannot directly communicate with other stations beyond one network.

(2) Hierarchical link

When 2 sets of JW-20MN are mounted on the optional slot of the basic rack panel, hierarchical link communication is possible and can increase the number of stations.

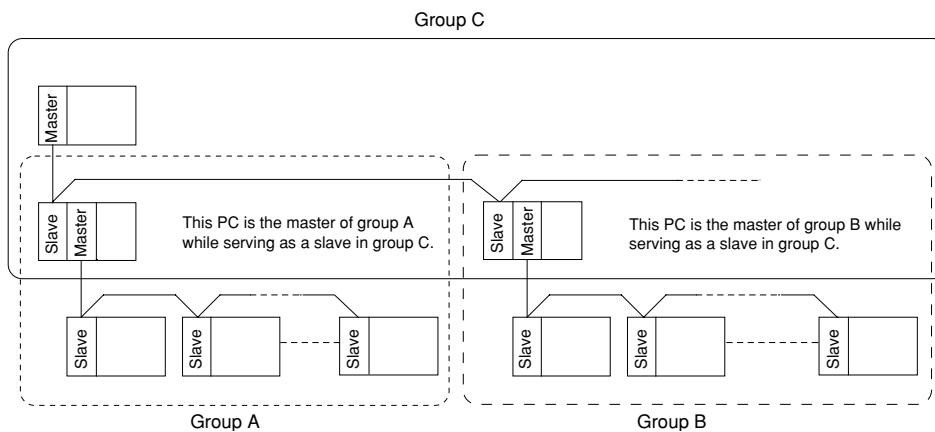
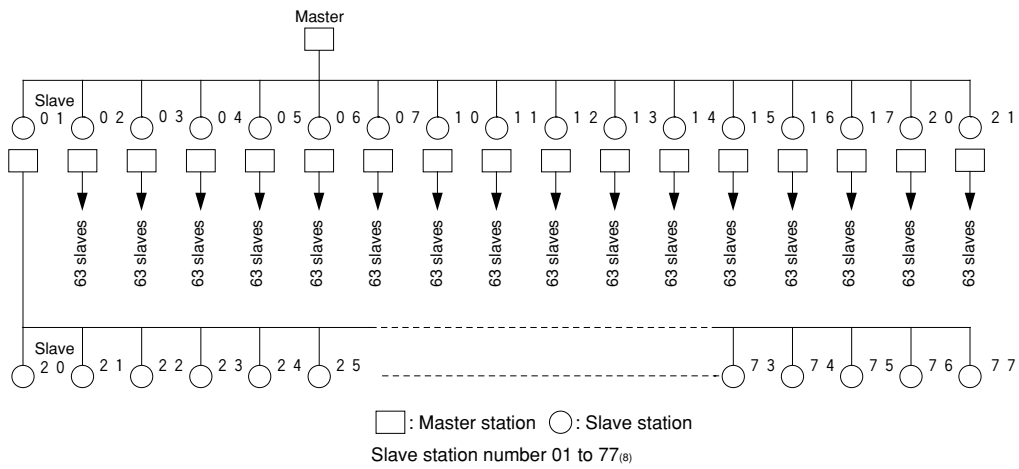

Remarks

- Pay attention to hierarchical link system consisting of more than two levels as it takes time for communication between the stations at the highest level and at the lowest level.
- Though more than one JW-20MN can be mounted on single basic rack panel, they cannot directly communicate with other stations beyond one network.

Chapter 9: Description of the Computer Link Operation

When connected to a host computer with a network module that is compatible with the ME-NET specifications, the JW-20MN can transfer data.

9-1 Computer link function

Instructions from the host computer are referred to as “commands.” Replies to the commands from each of the connected devices are referred to as “responses.”

In order to use the computer link function, you must use application software which can send commands and receive responses from the oppsite stations. Concerning how to use the host computer, see the respective instruction manual.

ME-NET computer link commands are classified into two categories as follows:

① Basic commands

Commands mainly used with PCs. (See page 9-3)

These commands are the functions used to read and write relays and registers. The JW-20MN supports all of the basic commands (for both the 47 and 57 family).

Reference

The 47 and 57 family: ME-NET computer link commands are divided into the 47 and 57 families of commands, which use different communication formats. However, you do not need to be concerned about the differences in these families when using the computer link function.

② Optional commands

Commands other than the basic commands. These are individual commands specific to each device. (See page 9-5)

This manual describes the meaning of each command and the range of usable memory address. For details about the transmission method used for each command, see the instruction manual for the host computer.

9-2 Communication method

The host computer communicates with each station number one by one.

- ① The host computer instructs station number/communication contents/memory address/data etc. of the communicating station as a “command.”
- ② The “command” receiving station processes this data and returns the result as “response.”

(System example)

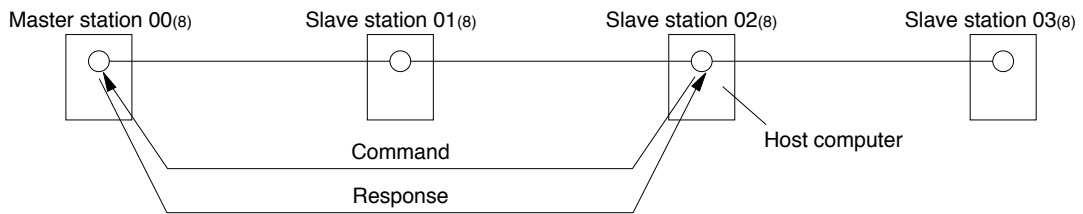

On the computer link, the host computer can communicate with any required station regardless of whether it is the master or slave station.

*** For details about the computer link function, see the instruction manual that came with the network module for the computer.**

9-3 Basic command

The meaning and usable memory address range of each command are shown below:

- The number for each command is the command identification number which is assigned by the ME-NET specifications.
- When a W70H/100H PC is used, reading and writing is limited to the file registers marked with asterisks “*”.
- Reading and writing to/from registers can be performed in blocks up to 1024 bytes in one instruction.
- To write to certain registers, you have to prepare data length equal to number bytes of the registers to write.
- Writing mode assignment is used to show whether writing to the PC memory has been enabled or disabled.

0 : Writing prohibited

1 : Enable writing only to data memory

2 : Enable writing all data.

(See command number F9_(H))

Command	Assignable address range and precautions	Write mode assignment															
Read relay 20 _(H)	00000 to 15777 (relay), T0000 to T0777 (TMR, CTR contact points) T or C0000 to 0777 (TMR, CTR contacts at W70H/100H, JW50H/70H/100H) T or C1000 to 1777 (TMR, CTR contacts at JW50H/70H/100H) Assign in units of individual point	None															
Set or reset relay 30 _(H)	00000 to 15777 (relay), SET=1, RESET=0, Assign in units of individual point	1 or 2															
Read the current register 24 _(H)	<table border="0"> <tr> <td>┓ 0000 to ┓ 1577 (*)</td> <td>b0000 to b1777 (*)</td> <td>09000 to 09777 (*)</td> </tr> <tr> <td>19000 to 19777 (*)</td> <td>29000 to 29777</td> <td>39000 to 39777</td> </tr> <tr> <td>49000 to 49777</td> <td>59000 to 59777</td> <td>69000 to 69777</td> </tr> <tr> <td>79000 to 79777</td> <td>89000 to 89777</td> <td>99000 to 99777</td> </tr> <tr> <td>E0000 to E0777</td> <td>E1000 to E1777</td> <td></td> </tr> </table>	┓ 0000 to ┓ 1577 (*)	b0000 to b1777 (*)	09000 to 09777 (*)	19000 to 19777 (*)	29000 to 29777	39000 to 39777	49000 to 49777	59000 to 59777	69000 to 69777	79000 to 79777	89000 to 89777	99000 to 99777	E0000 to E0777	E1000 to E1777		None
┓ 0000 to ┓ 1577 (*)	b0000 to b1777 (*)	09000 to 09777 (*)															
19000 to 19777 (*)	29000 to 29777	39000 to 39777															
49000 to 49777	59000 to 59777	69000 to 69777															
79000 to 79777	89000 to 89777	99000 to 99777															
E0000 to E0777	E1000 to E1777																
Write to register 34 _(H)	<table border="0"> <tr> <td>┓ 0000 to ┓ 1577 (*)</td> <td>b0000 to b1777 (*)</td> <td>09000 to 09777 (*)</td> </tr> <tr> <td>19000 to 19777 (*)</td> <td>29000 to 29777</td> <td>39000 to 39777</td> </tr> <tr> <td>49000 to 49777</td> <td>59000 to 59777</td> <td>69000 to 69777</td> </tr> <tr> <td>79000 to 79777</td> <td>89000 to 89777</td> <td>99000 to 99777</td> </tr> <tr> <td>E0000 to E0777</td> <td>E1000 to E1777</td> <td></td> </tr> </table>	┓ 0000 to ┓ 1577 (*)	b0000 to b1777 (*)	09000 to 09777 (*)	19000 to 19777 (*)	29000 to 29777	39000 to 39777	49000 to 49777	59000 to 59777	69000 to 69777	79000 to 79777	89000 to 89777	99000 to 99777	E0000 to E0777	E1000 to E1777		1 or 2
┓ 0000 to ┓ 1577 (*)	b0000 to b1777 (*)	09000 to 09777 (*)															
19000 to 19777 (*)	29000 to 29777	39000 to 39777															
49000 to 49777	59000 to 59777	69000 to 69777															
79000 to 79777	89000 to 89777	99000 to 99777															
E0000 to E0777	E1000 to E1777																
Write the same data to register 35 _(H)	<table border="0"> <tr> <td>┓ 0000 to ┓ 1577 (*)</td> <td>b0000 to b1777 (*)</td> <td>09000 to 09777 (*)</td> </tr> <tr> <td>19000 to 19777 (*)</td> <td>29000 to 29777</td> <td>39000 to 39777</td> </tr> <tr> <td>49000 to 49777</td> <td>59000 to 59777</td> <td>69000 to 69777</td> </tr> <tr> <td>79000 to 79777</td> <td>89000 to 89777</td> <td>99000 to 99777</td> </tr> </table>	┓ 0000 to ┓ 1577 (*)	b0000 to b1777 (*)	09000 to 09777 (*)	19000 to 19777 (*)	29000 to 29777	39000 to 39777	49000 to 49777	59000 to 59777	69000 to 69777	79000 to 79777	89000 to 89777	99000 to 99777				
┓ 0000 to ┓ 1577 (*)	b0000 to b1777 (*)	09000 to 09777 (*)															
19000 to 19777 (*)	29000 to 29777	39000 to 39777															
49000 to 49777	59000 to 59777	69000 to 69777															
79000 to 79777	89000 to 89777	99000 to 99777															
Set / reset TMR, CTR 32 _(H)	0000 to 0777 (When using W70H/100H, JW50/70/100) 0000 to 1777 (When using JW50H/70H/100H) SET=1, RESET=0 Assign in units of individual contact point.																

(Numeric figures of each command is the command identification number which is assigned by the ME-NET specifications.)

Command	Assignable address range and precautions	Write mode assignment
Read the file register current value 24 _(H)	File 0 000000 to 017777 (*) File 1, 2 000000 to 177777 (*) File 3 to 7 000000 to 177777 Assignable up to 1024 bytes at a time	None
Write to file register 34 _(H)	File 0 000000 to 017777 (*) File 1, 2 000000 to 177777 (*) File 3 to 7 000000 to 177777	1 or 2
Read program memory 04 _(H)	Assignable up to 1024 bytes at a time W70H/100H 000000 to 076777 JW50, JW50H 000000 to 016777 JW70/100 } 000000 to 076777, 100000 to 176777 JW70H/100H } (Addresses may vary with memory size) Assignable up to 512 steps at a time The JW-20CM reads out data in machine codes.	None
Write to program memory 14 _(H)	W70H/100H 000000 to 076777 JW50, JW50H 000000 to 016777 JW70/100 } 000000 to 076777, 100000 to 176777 JW70H/100H } (Addresses may vary with memory size) Assignable up to 512 steps at a time This command cannot be executed unless the PC operation has been stopped by the 「PC operation halt」 command or 「write mode assignment: 2.」	2
Read the PC operating status E8 _(H)	_____	None
Halt the PC operation F8 _(H)	When this command is executed, the PC cannot be started by a trigger from support tools attached to the PC.	
Restart the PC operation F8 _(H)	This command is only effective when the communication has been stopped by the 「PC operation halt」 command. If the PC stops operation for any other reason, this command is not effective.	
Read the write mode status E9 _(H)	_____	
Assign a write mode F9 _(H)	Select any of the following: Write prohibited = 0 Enables writing to data memory = 1 Enables writing to all memory = 2	
Read the brand code 6F _(H)	The JW-20MN returns the brand code (CL = Sharp) and model code (A = JW-20MN).	

9-4 Optional commands

The JW-20MN optional commands are any commands not specified in the ME-NET specifications. These are commands specific to the JW-20MN. The host computer may use these optional commands for communication between JW-20MNs and PCs with a JW-21MN installed. The table below shows optional commands (1) to (10) for the JW-20MN.

Optional command	Reference page
(1) Monitor TMR, CNT, and MD	9·6
(2) Read PC mode	9·7
(3) Set PC mode	9·7
(4) Read system memory	9·8
(5) Write system memory	9·9
(6) Read date	9·10
(7) Set date	9·10
(8) Read time	9·11
(9) Set time	9·11
(10) Correct time	9·12

[Communication format, basic pattern]

■ Command

“+”	“C”	“L”	“A”	CMD	SUB	ATTR	C.TEXT
-----	-----	-----	-----	-----	-----	------	--------

■ Response (normal)

“+”	ACK	“C”	“L”	“A”	CMD	SUB	ATTR	R.TEXT
-----	-----	-----	-----	-----	-----	-----	------	--------

(Response on error: See page 9·12)

Symbol	Data	Contents
“+”	2B _(H)	Optional command
“C”	43 _(H)	Sharp brand ID code
“L”	4C _(H)	
“A”	41 _(H)	Model code (JW-20MN)
CMD	*1	Function code
SUB	*2	Sub code
ATTR	00 _(H)	Always set to 00 _(H)
C. TEXT	*3	Instruction contents for each optional command
R. TEXT		
ACK	00 _(H)	When normal, the response should be 00 _(H)

*1, *2, *3

See each optional command (9·6 to 9·12)

(1) Monitor TMR, CNT, and MD

Read out the current value and attribute data from TMR, CNT, and MD in the specified area.

[Write mode assignment] No

[Communication format]

■ **Command**

“+”	“C”	“L”	“A”	CMD	SUB	ATTR	TMRNO	N
-----	-----	-----	-----	-----	-----	------	-------	---

■ **Response**

“+”	ACK	“C”	“L”	“A”	CMD	SUB	ATTR	TMRNO	N
		D1		DN		TA1		TAN	

Symbol	Data	Contents
CMD	42 _(H)	Function code
SUB	23 _(H)	Sub code
TMRNO	000 to 777 ₍₈₎	TMR, CNT, and MD numbers (two data bytes in sequential order, L, then H)
N	0000 to 0100 _(H)	Amount of data read (two data bytes in sequential order, L, then H)
D1 to DN	See the example	Read current data value (two data bytes x the number of values read)
TA1 to TAN	00 _(H)	Do not use as TMR, CNT, or MD
	01 _(H)	ZW/JW MD
	02 _(H)	ZW CNT
	04 _(H)	ZW TMR
	08 _(H)	DTMR (BCD)
	09 _(H)	DTMR (BIN)
	0A _(H)	UTMR (BCD)
	0B _(H)	UTMR (BIN)
	0C _(H)	DCNT (BCD)
	0D _(H)	DCNT (BIN)
	0E _(H)	UCNT (BCD)
	0F _(H)	UCNT (BIN)

One data byte
x
number of values read

(See page 9-5 for other symbols not described above)

[Example] Read the current value of TMR, CNT, and MD at addresses 000 to 002₍₈₎

(The data in cells are in hexadecimal notation)

■ **Command**

2B	43	4C	41	42	23	00	00	00	03	00
“+”	“C”	“L”	“A”	CMD	SUB	ATTR	000 ₍₈₎			3 pieces

■ **Response**

2B	00	43	4C	41	42	23	00	00	00	03	00
ACK				CMD		SUB	ATTR	000 ₍₈₎			3 pieces

65	38	32	60	14	73	08	0C	0E
Current value of No. 000	Current value of No. 001	Current value of No. 002	DTMR	DCNT	UCNT	000	001	002
3685	6032	7314	(BCD)	(BCD)	(BCD)			

(2) PC mode reading

Read PC's mode

[Write mode assignment] No

[Communication format]

■ Command

"+"	"C"	"L"	"A"	CMD	SUB	ATTR
-----	-----	-----	-----	-----	-----	------

■ Response

"+"	ACK	"C"	"L"	"A"	CMD	SUB	ATTR	MODE
-----	-----	-----	-----	-----	-----	-----	------	------

Symbol	Data	Contents
CMD	43(H)	Function code
SUB	4E(H)	Sub code
MODE	00(H)	Monitor mode
	02(H)	Change mode
	03(H)	Program mode

(See page 9-5 for other symbols not listed on the left)

[Example] When the PC reads the program mode,
(Data in cells: Hexadecimal notation)

Command

2B	43	4C	41	43	4E	00
"+"	"C"	"L"	"A"	CMD	SUB	ATTR

Response

2B	00	43	4C	41	43	4E	00	03
	ACK				CMD	SUB	ATTR	Program Mode

(3) PC mode setting

Set the PC to an assigned mode

[Write mode assignment] No

[Communication format]

■ Command

"+"	"C"	"L"	"A"	CMD	SUB	ATTR	MODE
-----	-----	-----	-----	-----	-----	------	------

■ Response

"+"	ACK	"C"	"L"	"A"	CMD	SUB	ATTR
-----	-----	-----	-----	-----	-----	-----	------

Symbol	Data	Contents
CMD	43(H)	Function code
SUB	5E(H)	Sub code
MODE	00(H)	Monitor mode
	02(H)	Change mode
	03(H)	Program mode

(See page 9-5 for other symbols not listed on the left)

[Example] When to set the PC to the change mode.
(Data in cells: Hexadecimal notation)

Command

2B	43	4C	41	43	5E	00	02
"+"	"C"	"L"	"A"	CMD	SUB	ATTR	Change mode

Response

2B	00	43	4C	41	43	5E	00
	ACK				CMD	SUB	ATTR

(4) Reading system memory

Read the specified number of bytes of data from the specified address in system memory.

[Write mode assignment] No

[Communication format]

■ **Command**

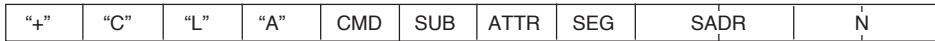

■ **Response**

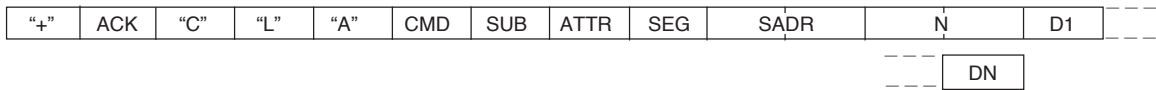

CMD	43 _(H)	Function code
SUB	4E _(H)	Sub code
SEG	08 _(H)	Segment to read
SADR	0000 to 00FF _(H)	Address to read #000 to #377 ₍₈₎ (two data bytes in sequential order, L, then H)
N	0001 to 00FF _(H)	Number of bytes of read (two data bytes in sequential order, L, then H)
D1 to DN	See the example	Data to read the system memory. (One byte X number of bytes to read)

[Example] To read data from system memory addresses #201 and #202
(Data in cells: Hexadecimal notation)

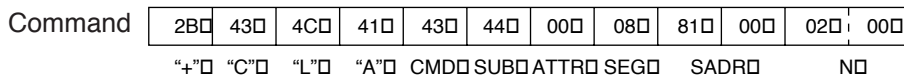

Response

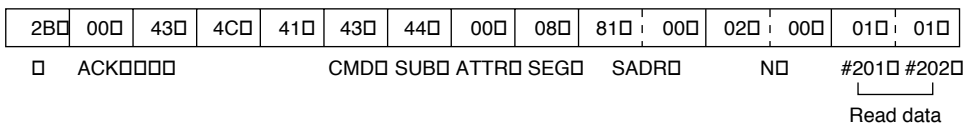

(5) Write to system memory

Write the specified number of bytes of data from the specified address in system memory.

[Write mode assignment] 2 (When the PC has been stopped with a “halt PC operation F8 ”
command) ^(H)

[Communication format]

■ Command

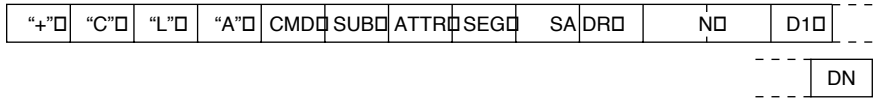

■ Response

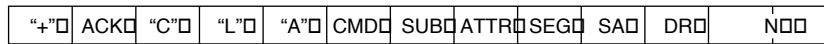

Symbol	Data	Contents
CMD	43 ^(H)	Function code
SUB	54 ^(H)	Sub code
SEG	08 ^(H)	Segment to write
SADR	0000 to 00FF ^(H)	Address to write #000 to #377 ⁽⁸⁾ (two data bytes in sequential order, L, then H)
N	0001 to 00FF ^(H)	Number of bytes to write (two bytes of data. The reserved area is prohibited to write.)
D1 to DN	See the example	Data to write in the system memory (One byte x number of bytes to write)

[Example] To write data 01^(H), 01^(H) to data from system memory addresses #201 and #202
(201⁽⁸⁾ = 81^(H)) Data in cells: Hexadecimal notation)

Command

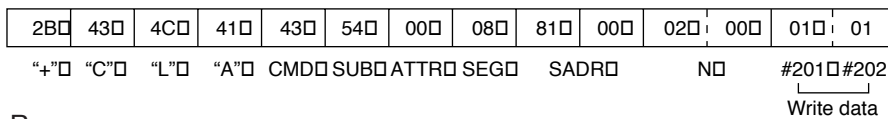

Response

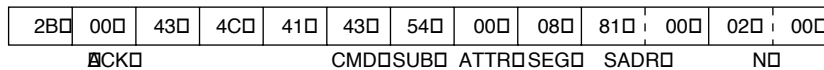

(8) Read out time

Read out time (hour, minute, second) of clock.

[Write mode assignment] No

[Communication format]

■ Command “+” “C” “L” “A” CMD SUB ATTR

■ Response “+” ACK “C” “L” “A” CMD SUB ATTR H M S

Symbol	Data	Contents
CMD	45 _(H)	Function code
SUB	A3 _(H)	Sub code
H	00 to 23 _(H)	00 to 23 hour
M	00 to 59 _(H)	00 to 59 minutes
S	00 to 59 _(H)	00 to 59 seconds

(See page 9-5 for other symbols not listed on the left)

[Example] Reading a time of 8 : 30 : 30 AM. (The data in cells are in hexadecimal notation)

Command 2B 43 4C 41 45 A3 00
 “+” “C” “L” “A” CMD SUB ATTR

Response 2B 00 43 4C 41 45 A3 00 08 30 30
 ACK CMD SUB 8: 30: 30AM

(7) Set time

Set time (hour, minute, second) of clock.

[Write mode assignment] 1 or 2

[Communication format]

■ Command “+” “C” “L” “A” CMD SUB ATTR H M S CTRL

■ Response “+” ACK “C” “L” “A” CMD SUB ATTR

Symbol	Data	Contents
CMD	45 _(H)	Function code
SUB	B3 _(H)	Sub code
H, M, S		Same method as “reading the time” above.
CTRL	00 _(H)	At operation of the clock
	01 _(H)	Stop operation of the clock
	02 _(H)	Reset the seconds
	08 _(H)	Correct to 30 seconds (0 to 29 seconds will reset to 0, 30 to 59 seconds will reset to one minute)

[Example] When the time is 13 : 30 : 00. (The data in cells are in hexadecimal notation)

Command 2B 43 4C 41 45 B3 00 13 30 00 00
 “+” “C” “L” “A” CMD SUB ATTR 13 30 00At operation

Response 2B 00 43 4C 41 45 B3 00
 ACK CMD SUB

(10) Correct the clock time.

Correct time of clock.

[Write mode assignment] 1 or 2

[Communication format]

■ Command "+" "C" "L" "A" CMD SUB ATTR CTRL

■ Response "+" ACK "C" "L" "A" CMD SUB ATTR

Symbol	Data	Contents
CMD	45 _(H)	Function code
SUB	B4 _(H)	Sub code
CTRL	00 _(H)	At operation of the clock
	01 _(H)	Stop operation of the clock
	02 _(H)	Reset the seconds
	08 _(H)	Correct to 30 seconds (0 to 29 seconds will reset to 0, 30 to 59 seconds will reset to one minute)

[Example] To stop the clock. (The data in cells are in hexadecimal notation)

Command 2B 43 4C 41 45 B4 00 01
 "+" "C" "L" "A" CMD SUB ATTR Stop operation

Response 2B 00 43 4C 41 45 B4 00
 ACK CMD SUB

(11) Response on error

When a station that has received data encounters an error while processing data after receiving an optional command from the host computer, it will send a response as follows.

■ Response (response) "+" ACK "C" "L" "A" CMD ERR

ACK data	ERR data	Contents
01 _(H)	None	The command data format is not appropriate
06 _(H)	None	The PC has not stopped operation
07 _(H)	None	The data is not written properly
0F _(H)	None	Time out while accessing memory
10 _(H)	None	Write mode is not appropriate
11 _(H)	None	The assigned address is outside the program area.
FF _(H)	02 _(H)	The assigned address is other than the set values for TMR, CNT, or MD.
	04 _(H)	Set or reset the MD.
	05 _(H)	The set value for the number of bytes exceeds the rated range.
	13 _(H)	Set or reset the TMR or CNT while the PC is stopped.
	52 _(H)	Start/end block error
	53 _(H)	System memory is not correct

· Symbols other than above

"+" "C," "L" and "A" : Same as the description on page 9-5.

CMD: Function code for each optional command

(See pages 9-6 to 9-12.)

Chapter 10: Outline of Switch and Parameter Setting Procedure

10-1 Operation procedure

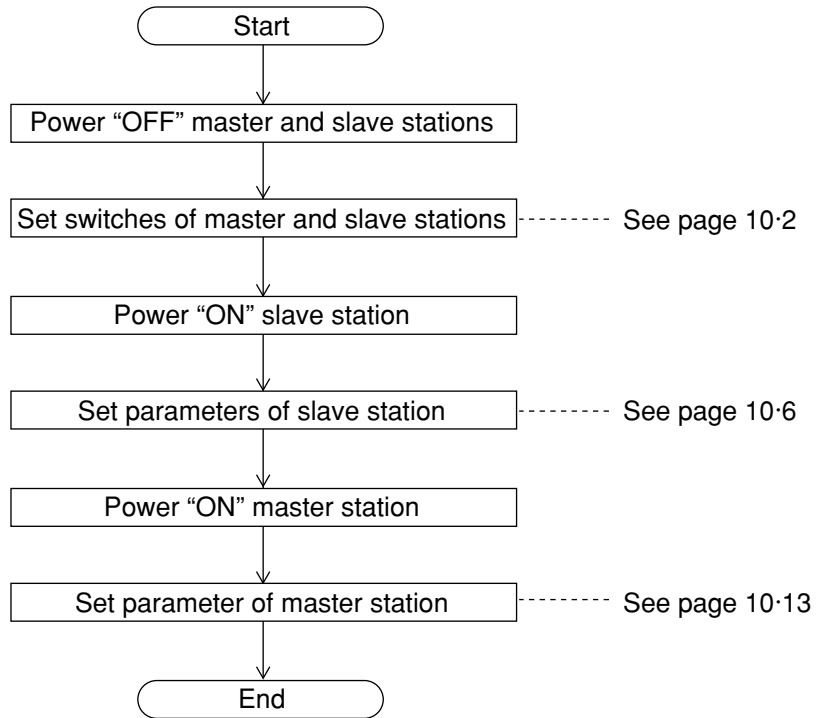

Remarks

- Make sure to turn "OFF" the power of the PC prior to setting the switches.
- Prior to setting the parameters of the JW-20MN, set its operation mode to "program mode."
- Make sure to write the set parameters into the EEPROM in the JW-20MN after setting.

10-2 Switch setting of master station and slave station

Set the switches below before using the JW-20MN.

(1) Mode switch (MODE)

Make sure to set to "2" or "3."

Setting value	Function
0	Do not select this position.
1	Do not select this position.
2	Data link (standard function)
	Computer link
3	Data link (memory capacity save function)
	Computer link
4 to F	Test mode A service man will use these switches for adjustment.

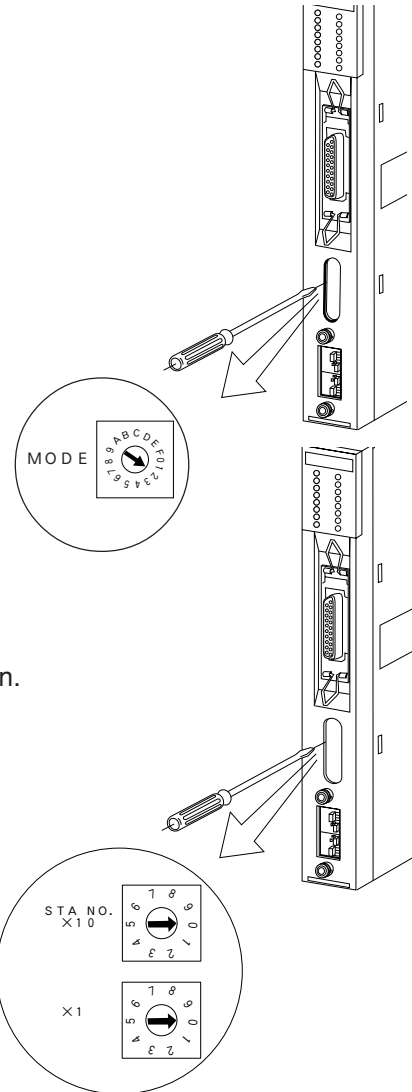

(2) Station number switch (STA NO. X 10, X 1)

- Make sure to set the master station number to "00."
- For slave stations, set from "01" to "77" sequential in octal notation.

Remarks

- Maximum amount of slave stations to be connected is 63.
- As the station number should be assigned using octal notation, setting of the following values causes errors and the JW-20MN cannot communicate.
08, 09, 18, 19, 28, 29, 38, 39, 48, 49, 58, 59, 68, 69, and 78 to 99.
Be careful that there is no doubly allocated number and no number has been skipped.

(3) Set LT (termination resistance) switch

When the JW-20MN is at either end the communication line, make sure to set the termination resistance switch "ON."

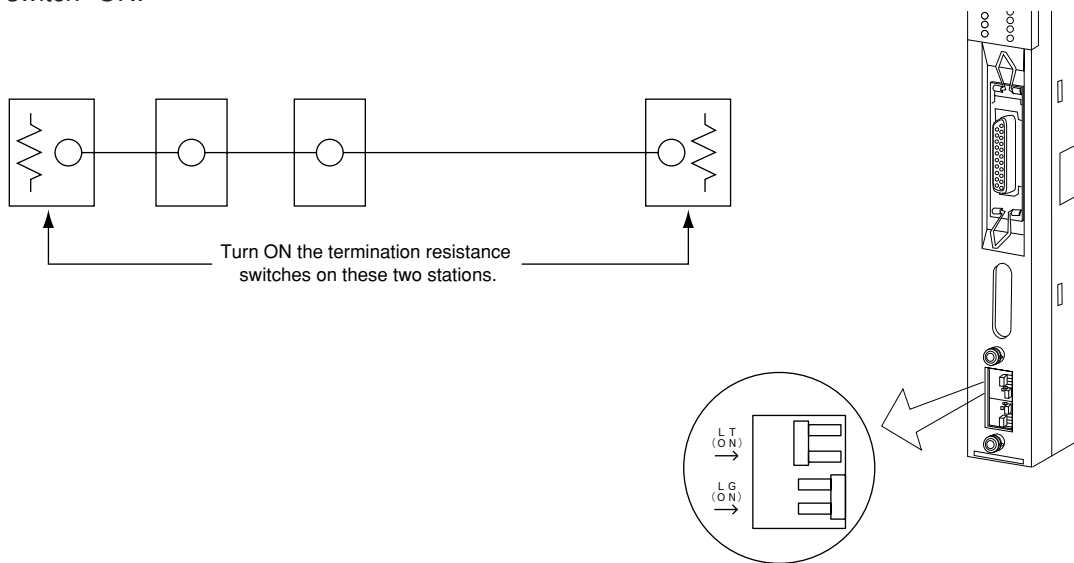

Setting	Condition of the JW-20MN
ON	Insert a termination resistance.
OFF	Do not insert a termination resistance

- If you use a terminator (termination resistance made by Toko Denshi: ME-75) at the end of a signal cable, turn OFF the termination resistance at the station on the end of the cable.

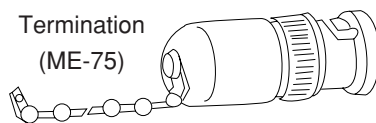
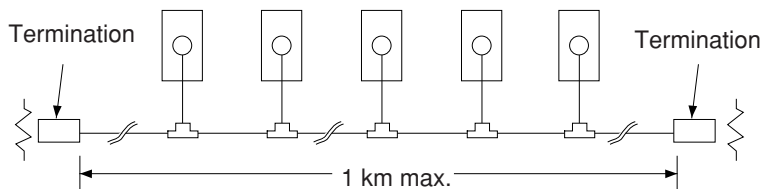

Reference

Need for the termination resistance

When a termination resistance is not provided at a communication circuit end, the end of the circuit generates reflection waves. These reflection waves collide with sending signals and abnormal communication may occur. The termination resistance prevents the occurrence of these reflection waves. On the other hand, when an intermediate station has its termination resistance switch turned "ON," this station causes reflection and attenuates signals and causes abnormal communication.

(4) Shield ground switch (LG)

For communication lines, use a coaxial cable.

As coaxial cable is an unbalanced circuit, ground its shield by turning "ON" the shield ground switch.

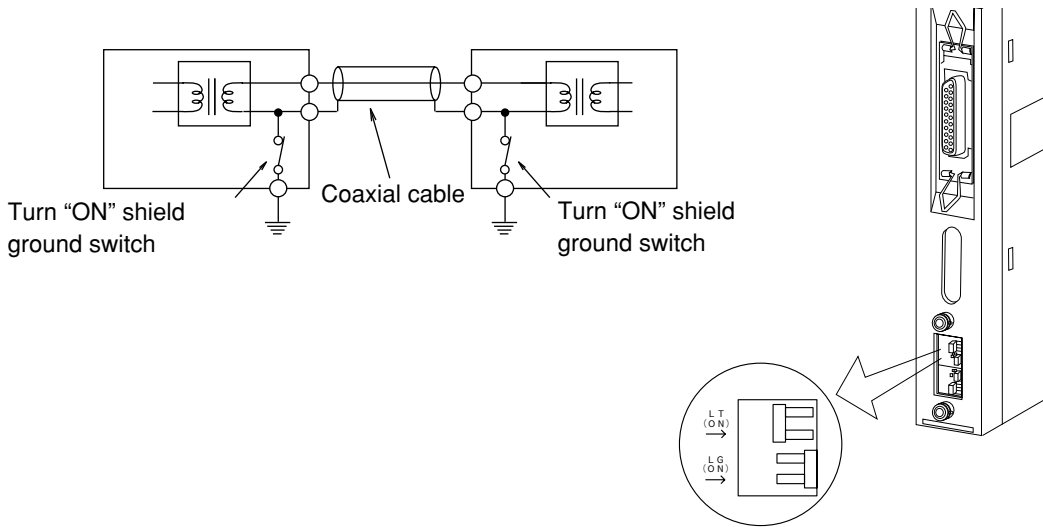

Setting	Condition of the JW-20MN
ON	Conductive between the shield and FG of the JW50H/70H/100H
OFF	Not conductive between the shield and FG of the JW50H/70H/100H

- Make sure to provide a class-3 grounding for the GND terminal of the power module. Without grounding the power module, the JW-20MN cannot become conductive with the ground after turning "ON" the shield ground switch. (See page 6-3.)

- Prior to any electric welding around the JW-20MN, take out the coaxial cable from the JW-20MN. While the coaxial cable is connected to the JW-20MN, any electric welding nearby the JW-20MN will cause the welding current to the JW-20MN and may damage part of its circuit pattern.

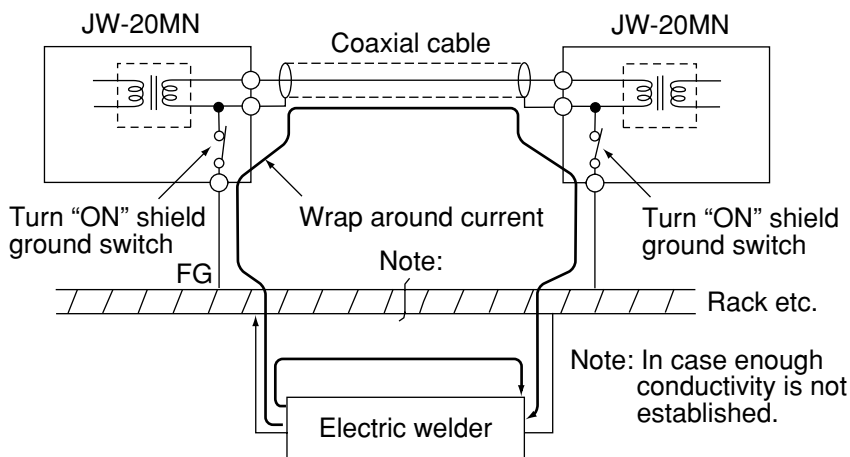

(5) Switches used to select between communication line 1 and 2 (L1, L2)

Select communication line.

Turn ON either of the L1 or L2 switch in order to select the communication line to be used.

Make sure to select the same line for all stations.

- When all the stations have their L1 switches ON, their L2 switches should be turned OFF.
- When all the stations have their L2 switches ON, their L1 switches should be turned OFF.

Connect a cable to the appropriate connector for the selected communication line.

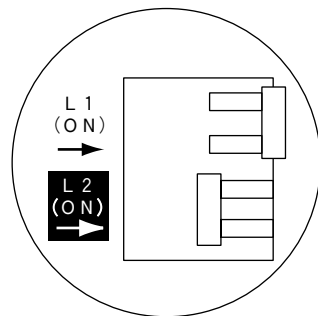
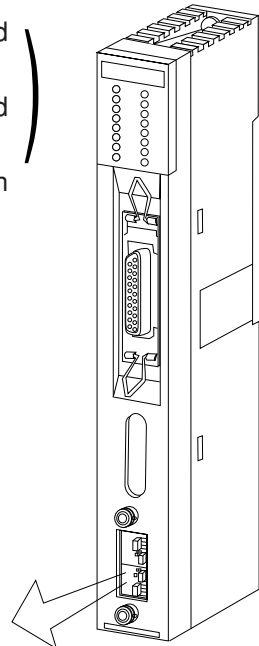

Remarks

· Setting examples using the system shown below.

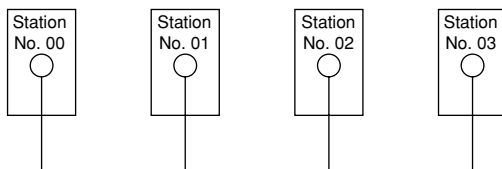

Switch	Station No.00	Station No.01	Station No.02	Station No.03	Operation
○	L1	ON	ON	ON	Normal communication on line 1 (L1). (Connect a coaxial cable to the L1 connector.)
	L2	OFF	OFF	OFF	
○	L1	OFF	OFF	OFF	Normal communication on line 2 (L2). (Connect a coaxial cable to the L2 connector.)
	L2	ON	ON	ON	
×	L1	OFF	ON	ON	The station No. 00 communication line is opened its circuit and the system cannot communicate normally.
	L2	OFF	OFF	OFF	
×	L1	ON	ON	ON	Since both L1 and L2 are turned ON, station No. 00 cannot communicate normally due to feedback and other similar problems.
	L2	ON	OFF	OFF	
×	L1	ON	OFF	ON	Since the L1 switch on station No. 01 is turned OFF, it cannot communicate.
	L2	OFF	ON	OFF	

10-3 Setting contents of slave station parameters (common for all slave stations)

When the JW-20MN is used as a slave station, set the following items for parameters.

[1] Setting contents

Setting item	Address ⁽⁸⁾	Initial value ^(H)	Contents		Corresponding signs on pages 11-7 and 11-8
① Number of receiving bytes of relay link V5	007720 007721	00	Set the number of bytes by decimals. (0 to 64) · If 0 is set, the number of bytes will be the same as the number of the sending bytes which is set in the master station		h_1 to h_n
② Number of receiving bytes of register link V5	007722 007723	00	Set the number of bytes by decimals. (0 to 512) · If 0 is set, the number of bytes will be the same as the number of the sending bytes which is set in the master station		i_1 to i_n
③ Top address of relay link area V5	007730 to 007733	00	Set file address in octal notation (see page 15-11 and 15-12)		f_1 to f_n
④ Top address of register link area V5	007734 to 007737	00	Set file address in octal notation (see page 15-11 and 15-12)		g_1 to g_n
⑤ *2 Whether the station number information should be output or not V5	007763	00	Store the number of own station in the data memory when setting on 01(H). (storage area of 1 byte follows flag area of 24 bytes)		—
⑥ Top address of flag area (communication and PC operation condition monitor flag)	007764	E0	Lower digits of file address	Hexadecimal: 01E0(H) ↓ Octal: 000740	e_1 to e_n
	007765	01	Upper digits of file address		
	007766	00	File number (00 + 007)		
	007767	80	Flag output (Yes: 80(H) No: 00(H))		
⑦ · Start/stop operation of the JW-20MN · Writing to EEPROM of the JW-20MN	007777	01	00(H): Stop operation		—
			01(H): Start operation		
			80(H): Writing to the EEPROM, stop operation		
			81(H): Writing to the EEPROM, start operation		
			08(H): Parameter initializing		

*1 Set only when the memory capacity save function is used.

*2 "Whether the station number information should be output or not" is a unique function of the JW-20MN.

① to ⑦ are equivalent to number of next page.

Notes

- Twenty four bytes can be used for the flag area, starting from the top. Set the area so that it is within the specified range (see pages 15-11 and 15-12).
- Set the top address of the flag area using the file addresses which are assigned throughout the network. Input and output relays, auxiliary relays, and PC registers are assigned a byte address for each individual item.
- Make sure that the flag area does not overlap the relay link area or the register link area set by the master station parameters.

Operation procedure

When not using the memory capacity save function.

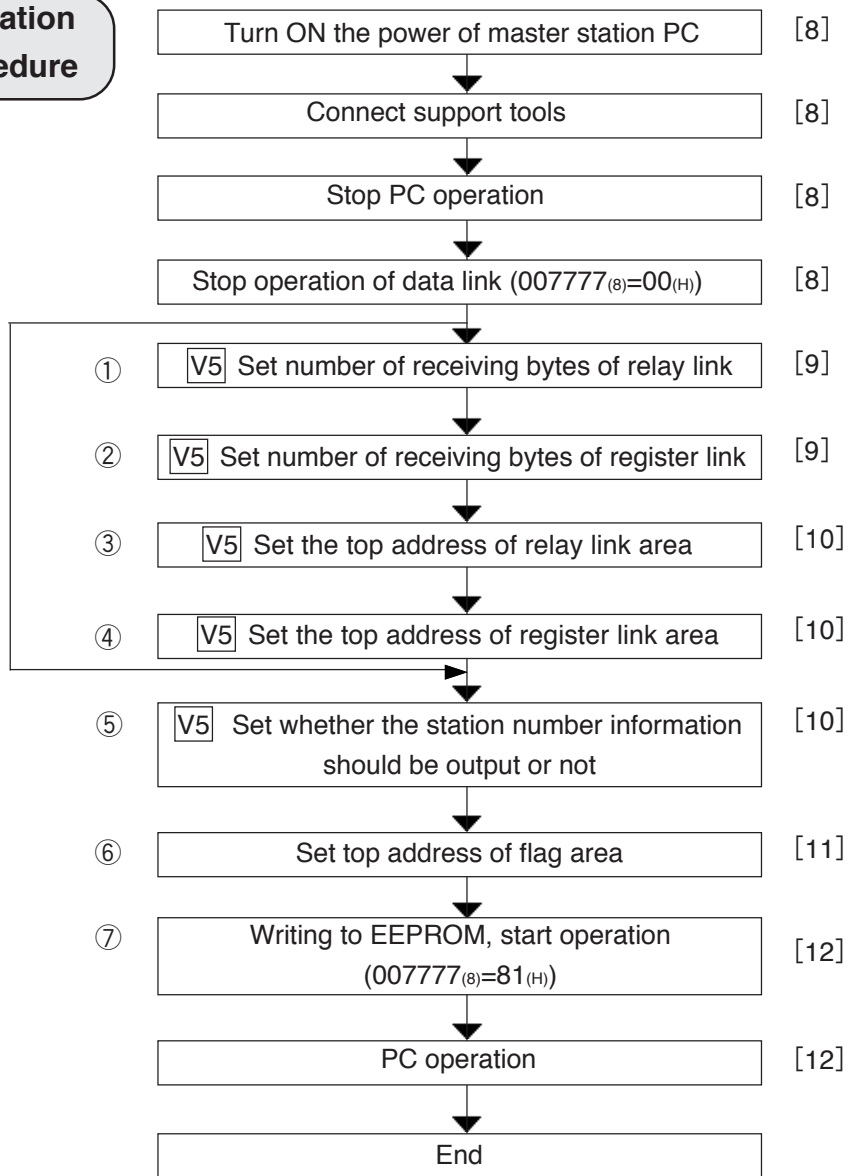

① to ⑦ are equivalent to number of previous page.

Turn "ON" the power of slave module.

Connect support tools

- Connect a support tool with the JW-20MN and prepare the setting parameter.

<Usable support tools>

JW-13PG/12PG

JW-50SP

JW-50PG, Z-100LP2S

- For operation of each support tool, see the instruction manual attached. The following describes an example of JW-13PG's key operation.

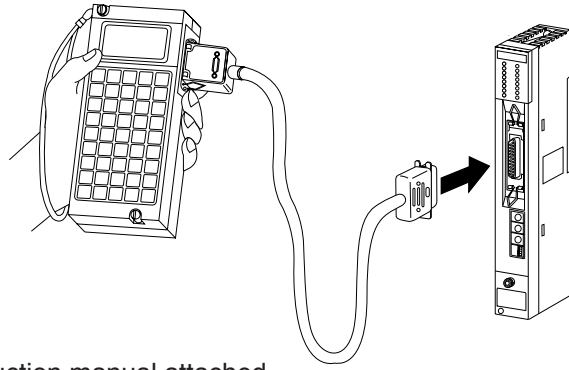

Stop PC operation

- Turn to program mode (stop PC operation). Setting of parameters is only available when the PC is in program mode.

(Operation example of JW-13PG)

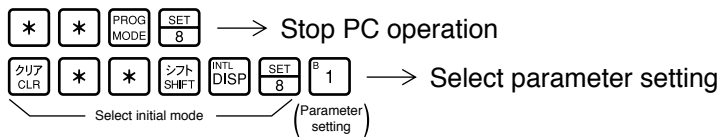

Stop operation of data link

[HEX (hexadecimal), byte]

- Setting of the parameter is only available when the operation of the JW-20MN is stopped.
- Write "00(H)" to parameter address 007777_(B) and stop operation of the JW-20MN.

(Operation example of JW-13PG)

Screen display of JW-13PG

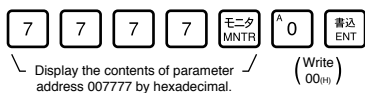

07775	HEX	00
07776	HEX	00
I PARAM.		
>07777	HEX	00

Reference Function of JW-13PG

- key : Changeover unit of figures
 (→HEX(hexadecimal)→OCT(octal)→DCM(decimal)→Bit pattern)
- key : Byte display ↔ Changeover word display

To the next page

From the previous page

“Only when the memory capacity save function is used.”

V5 Set the number of sending bytes of the relay link [DCM (decimal), word]

- Set the number of sending bytes in decimal on the parameter address 007720 to 007721⁽⁸⁾.

007720 ⁽⁸⁾	Lower
007721 ⁽⁸⁾	Upper

(In case of setting 4 bytes using JW-13PG: Example for slave station 02 of page 10-21)

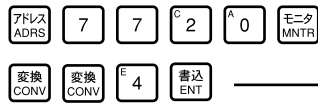

→ Display the contents of parameter addresses 007720 to 007721⁽⁸⁾

→ Write 00004^(D) after converting to decimal

Screen display of JW-13PG

07714	D	00000
07716	D	00000
I PARAM.		
>07720	D	00004

007720 ⁽⁸⁾	0 0 0 0 4 (D)
007721 ⁽⁸⁾	

“Only when the memory capacity save function is used.”

V5 Set the number of receiving bytes of register link [DCM (decimal), word]

- Set the number of sending bytes in decimal on the parameter address 007722 to 007723⁽⁸⁾.

007722 ⁽⁸⁾	Lower
007723 ⁽⁸⁾	Upper

(In case of setting 8 bytes for parameter addresses 007722 to 007723⁽⁸⁾ using JW-13PG: Example for slave station 02 of page 10-21)

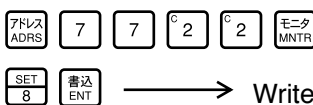

→ Display the contents of parameter addresses 007722 to 007723⁽⁸⁾

→ Write 00008^(D) after converting to decimal

Screen display of JW-13PG

07716	D	00000
07720	D	00004
I PARAM.		
>07722	D	00008

007722 ⁽⁸⁾	0 0 0 0 8 (D)
007723 ⁽⁸⁾	

To the next page

From the previous page

“Only when the memory capacity save function is used.”

V5 Set top address of relay link area. [File address: OCT (octal), word
File number: HEX (hexadecimal), byte]

- Set file address in parameter address 007730 to 007733⁽⁸⁾.
These top addresses should not overlap the register link area, flag area, or any area used by other option module.

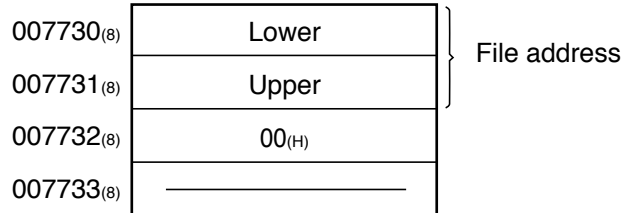

In case of setting 01000 (file address 001000⁽⁸⁾) using JW-13PG: Example for slave station 02 of page 10-21.

アドレス ADRS [7] [7] [3] [0] モニタ MNTF → Display the contents of parameter address 007730 to 007731⁽⁸⁾.

変換 CONV [B] [1] [A] [0] [A] [0] [A] [0] 書込 ENT → Write 001000⁽⁸⁾

STEP (+) [A] [0] 書込 ENT → Write parameter address 007732 to 007733⁽⁸⁾ for 000000⁽⁸⁾.

Screen display of JW-13PG

07726	0	000000
07730	0	001000
I PARAM.		
>07732	0	000000

“Only when the memory capacity save function is used.”

V5 Set register link area of register link area. [File address: OCT (octal), word
File number: HEX (hexadecimal), byte]

- Set file address in parameter address 007734 to 007737⁽⁸⁾.
These top addresses should not overlap the relay link area, flag area, or any area used by other option module.

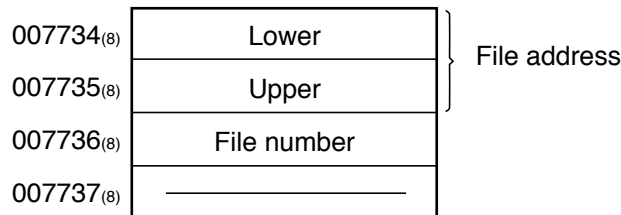

In case of setting 09000 (file address 004000⁽⁸⁾) using JW-13PG: Example for slave station 02 of page 10-21.

STEP (+) [E] [4] [A] [0] [A] [0] [A] [0] 書込 ENT → Write parameter address 007734 to 007735⁽⁸⁾ for 004000⁽⁸⁾.

STEP (+) [A] [0] 書込 ENT → Write parameter address 007736⁽⁸⁾ for file number 0.

Screen display of JW-13PG

07732	0	000000
07734	0	004000
I PARAM.		
>07736	0	000000

To the next page

From the previous page

V5 Set whether the station number information should be output or not

- Set whether the station number information should be output or not on the parameter address 007763₍₈₎.

007763₍₈₎ **Whether the station number information should be output or not**

- 00_(H): Do not output
- 01_(H): Output

The station number information is output on the next byte of the flag area (24 bytes.)

Set top address of flag area [**File address: OCT (octal), word**]
 [**File number: HEX (hexadecimal), byte**]

- Set the top address of the flag area (24 bytes) in order to monitor the communication condition and PC operation condition on the parameter address 007764 to 007767₍₈₎. (Setting area: See page 15-11, 12.)
- Flag area uses 24 bytes regardless number of connecting stations.

	Contents	Initial value	
007764 ₍₈₎	Lower	E0 _(H)	Byte address 01E0 _(H) → 000740 ₍₈₎ → 30740
007765 ₍₈₎	Upper	01 _(H)	
007766 ₍₈₎	File number	00 _(H)	File number 0
007767 ₍₈₎	D7	80 _(H)	Output flag

Output flag: ON
Do not output flag: OFF

To the next page

From the previous page

Writing to the EEPROM of the JW-20MN, start operation

[HEX (hexadecimal), byte]

- Write “81_(H)” into parameter address 007777₍₈₎ and write the set parameter contents into the EEPROM of the JW-20MN. Then start the JW-20MN.
- After starting operation, the setting value changes to “01_(H).”

Setting value _(H)	Contents
00	Stop operation of the JW-20MN
01	Start operation of the JW-20MN
80	Writing to the EEPROM of the JW-20MN, stop operation
81	Writing to the EEPROM of the JW-20MN, start operation
08	Initialize parameters

(Operation example of using JW-13PG)

Screen display of JW-13PG

7 7 7 7 MNTN SET 8 1 書込 ENT
 Display the contents of address 007777₍₈₎ Write 81_(H)

07775	HEX	00
07776	HEX	EC
I PARAM.		
>07777	HEX	81

Remarks

- Writing time to EEPROM is approximately 0.7 sec. When any error is found for parameter settings, the JW-20MN lights the error code (6F_(H)) by the indicator lamp. When error code 6F_(H) lights,
 - ① Check flag top address
 - ② If the master station also lights up with error code 6F_(H), check the top address and number of bytes in the relay link and register link in the master station which corresponds to the slave station in which the error occurred.
- Written contents into the EEPROM are automatically transferred to the RAM of the JW-20MN when turning ON the power of the PC. At transferring, the PC checks BCC and compares BCC check code of the parameter memory address (007776₍₈₎). When an error is found, the JW-20MN lights the error code (6E_(H)) by the indicator lamp.
- If “parameter initialization” is selected, the module initializes parameter addresses 004000 to 007776₍₈₎.

PC operation

- Turning a slave module to monitor or change mode (PC operation).

(Operation example of using JW-13PG)

Screen display of JW-13PG

* * MNTN MODE SET 8 → Monitor mode
 * * CHNG MODE SET 8 → Change mode

C00000
>

10

10-4 Setting contents of master station parameters

[1] Setting contents

When the JW-20MN is used as a master station, set the following items for parameters after setting switches.

For details of the parameter memory, see pages 13-9 to 15.

* Corresponding symbols on pages 10-15 to 17

Item	Address (8)	Initial value (H)	Contents (setting range)	*
① Top address of relay link area on the master station	004000 to 004001	00 _(H)	Set file address by octal notation (See pages 15-11, 15-12.)	a ₀
② Function	004002	00 _(H)	Set to 01 _(H)	—□
③ Number of connected stations	004003	00 _(H)	Set number of stations including master stations by decimal (002 to 064 _(D))	—□
④ Relay link area top address or number of offset bytes on slave station 01 to 77 ₍₈₎	004004 to 004377	00 _(H)	<div style="display: inline-block; width: 48%; vertical-align: top;"> ·□When a slave station is data link (standard function), set the top address by file address (8) (See pages 15-11 and 12) </div> <div style="display: inline-block; width: 48%; vertical-align: top;"> ·□When a slave station is data link (memory save function), set the number of offset bytes by decimal. (00000 to 00256_(D)) </div>	a ₁ to a ₇₇
⑤ Register link area top address on the master station	004400 to 004403	00 _(H)	Set file address by octal notation (See pages 15-11 and 12)	b ₀
⑥ Register link area top address or number of offset bytes on slave station 01 to 77 ₍₈₎	004404 to 004777	00 _(H)	<div style="display: inline-block; width: 48%; vertical-align: top;"> ·□When a slave station is data link (standard function), set the top address by file address (8) (See pages 15-11 and 12) </div> <div style="display: inline-block; width: 48%; vertical-align: top;"> ·□When a slave station is data link (memory save function), set the number of offset bytes by decimal. (00000 to 02048_(D)) </div>	b ₁ to b ₇₇
⑦ Number of relay link sending bytes of master station	005000 to 005001	00 _(H)	Set the number of bytes by decimal (0 to 256, within 0 to 256 in total)	c ₀
⑧ Set number of relay link sending bytes of slave station 01 to 77 ₍₈₎	005002 to 005177	00 _(H)	Set the number of bytes by decimal (0 to 256, within 0 to 256 in total)	c ₁ to c ₇₇
⑨ Number of register link sending bytes of master station	005200 to 005201	00 _(H)	Set the number of bytes by decimal (0 to 1024, within 0 to 2048 in total)	d ₀
⑩ Set number of register link sending bytes of slave station 01 to 77 ₍₈₎	005202 to 005377	00 _(H)	Set the number of bytes by decimal (0 to 1024, within 0 to 2048 in total)	d ₁ to d ₇₇
*1 ⑪ Connection condition of slave stations (error code output)	007750 to 007757	00 _(H)	Turn ON a bit corresponding to each bit. (See pages 15-10)	—□

* 1: "Connection condition of slave stations" is a unique function of the JW-20MN.

* Corresponding signs on pages 10·15 to 17

	Item	Address (8)	Initial value (H)	Contents (setting range)	*
⑫	* 1 Whether the station number information should be output or not	007763	00 _(H)	When 01 _(H) is entered, the JW-20MN stores own station number to the data memory (storage area = one byte next to 24 bytes of the flag area, effective when 007767 ₍₈₎ is 80 _(H)).	—
⑬	Flag area top address (communication and PC operation monitor flag)	007764	E0 _(H)	Select file address and output in octal. (See page 15·10)	e ₀
		007765	01 _(H)		
		007766	00 _(H)		
		007767	80 _(H)		
⑭	· Start/stop operation of the JW-20MN · Write data to EEPROM of the JW-20MN	007777	01 _(H)	Select from “00, 01, 08, 80, 81” with hexadecimal.	—

* 1 : “Whether the station number information should be output or not” is a unique function of the JW-20MN.

① to ⑭ correspond to numbers in page 10·18.

Notes

- Make sure that the relay link area, the register link area, and flag area do not overlap each other.
- Set the top address of the relay link area, register link area, and flag area using the file addresses assigned throughout the network. Input and output relays, auxiliary relays, and PC registers are assigned a byte address for each individual item.
- The total number of bytes sent or received by each station must be in the range 0 to 1024, including relay and register links.

[2] Communication area map

(1) In case that setting data link (the standard function) when the master station and all slave stations are JW-20MN.

○: Send ●: Receive

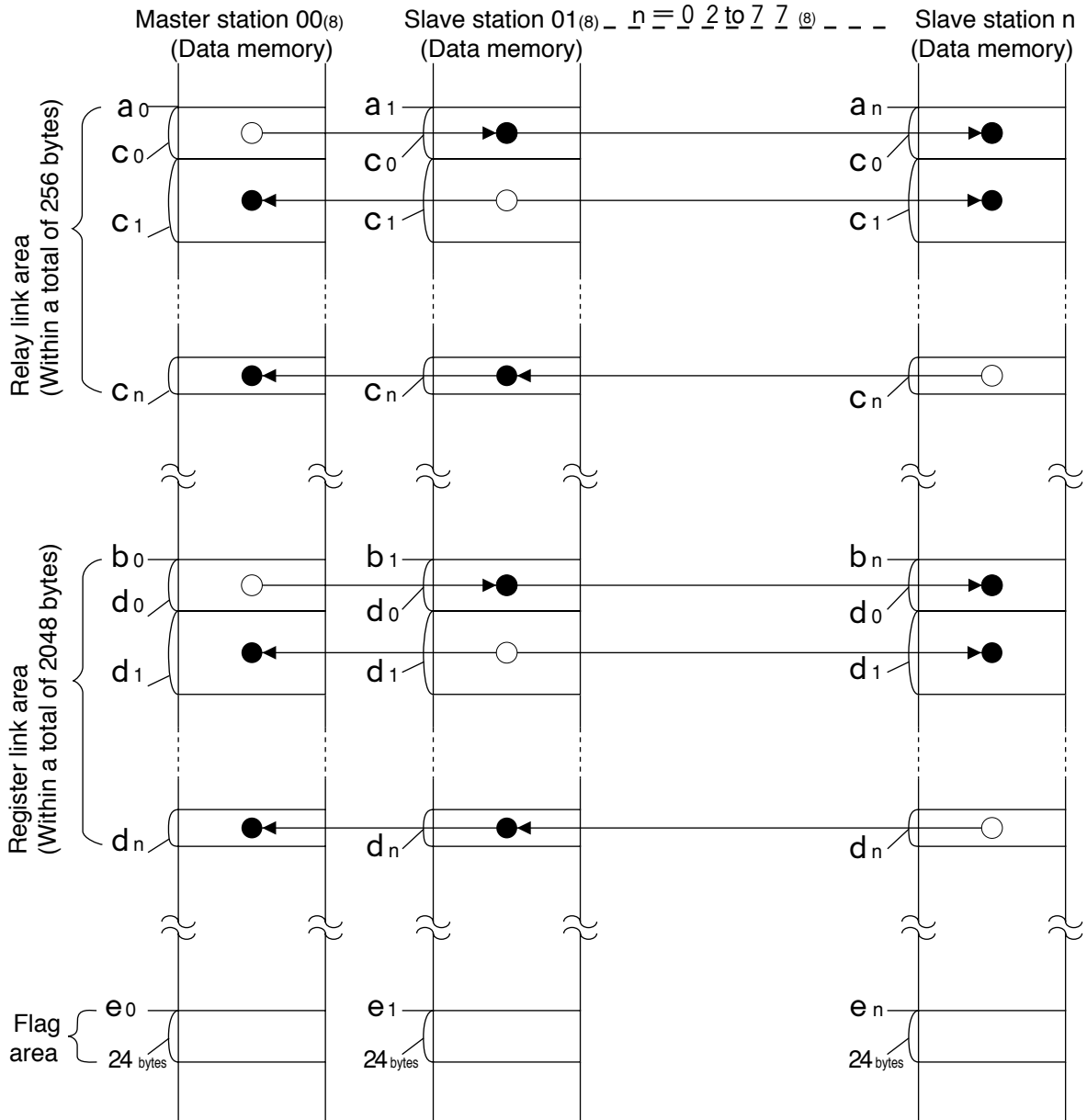

- Set the relay link area, register link area, flag area within the setting range nominated in page 15-11, 12. However, be careful not to double any address allocation of these.
- A maximum of 1024 bytes can be sent to or received by each station, including relay and register links.
 $c_0 + d_0, c_1 + d_1, c_n + d_n = 0$ to 1024 bytes
- Set a_0 to e_n parameters of master station and slave station. (See page 10-6, 13.)

Parameter for setting in master station	Parameter for setting in slave station
Top address of relay link area a_0, a_1 to a_n	Top address of flag area (slave station) e_1 to e_n
Top address of register link area b_0, b_1 to b_n	/
Number of sending bytes of relay link area c_0, c_1 to c_n	
Number of sending bytes of register link area d_0, d_1 to d_n	
Top address of flag area (master station) e_0 .	

(2) In case that setting the data link (V5 memory capacity save function) when the master station and all slave stations are JW-20MN.

Memory addresses inside control module of slave station continue in order of receiving and sending.

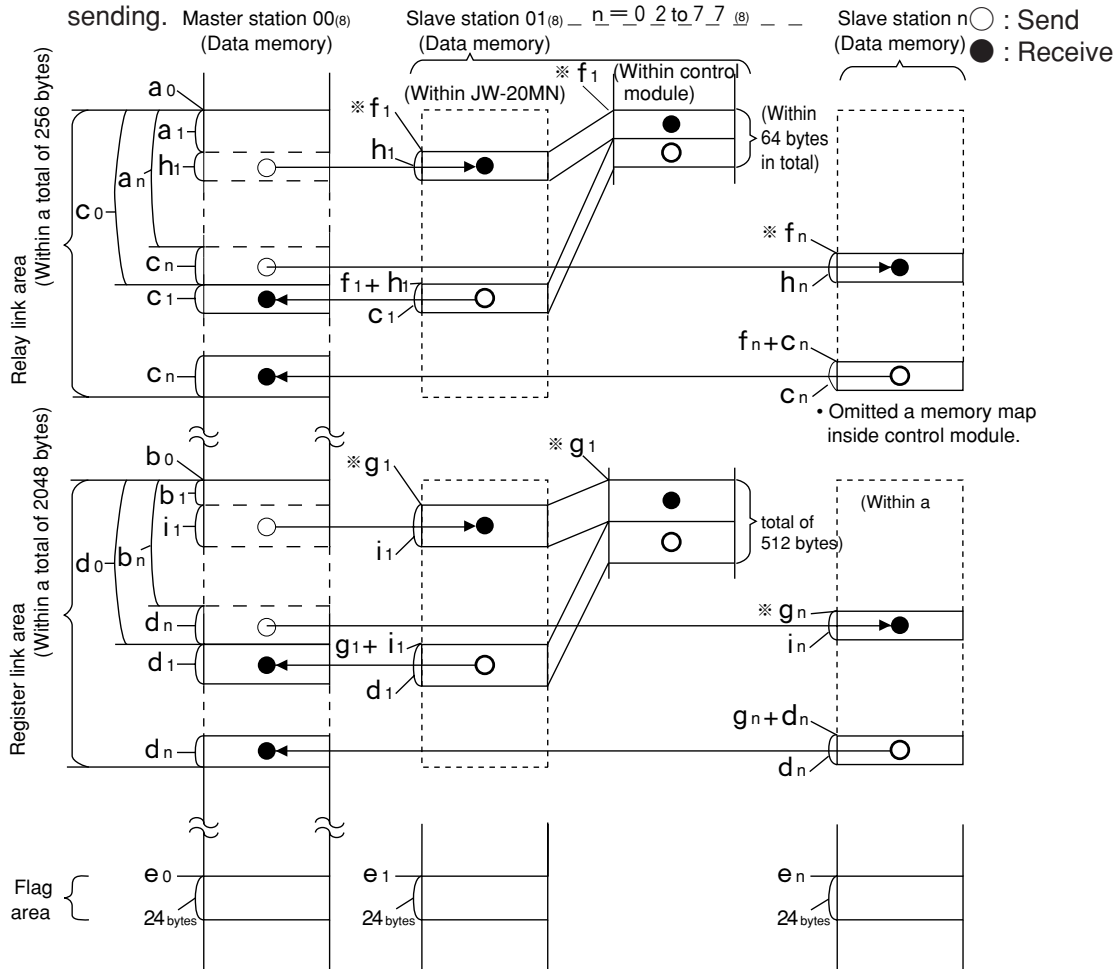

- Set the relay link area, the register link area, and the flag area within the settings range of page 15·11 and 15·12. Be careful not to double any address allocation of these.
- Set “a₀” to “i_n” above for parameters of master station and slave station (see page 10·6 and 10·13.)

Parameter for setting in master station	Parameter for setting in slave station
Top address of relay link area a ₀ , a ₁ to a _n	Top address of flag area (slave station) e ₁ to e _n
Top address of register link area b ₀ , b ₁ to b _n	Number of receiving bytes of relay link area f ₁ to f _n
Number of sending bytes of relay link area c ₀ , c ₁ to c _n	Number of receiving bytes of register link area g ₁ to g _n
Number of sending bytes of register link area d ₀ , d ₁ to d _n	Number of receiving bytes of relay link area h ₁ to h _n
Top address of flag area (master station) e ₀ .	Number of receiving bytes of register link area i ₁ to i _n

- Set the receiving area for memory capacity save function within the range of the link area.
 - 0 ≤ a₁ ≤ Total number of bytes of relay link area -h₁
 - 0 ≤ a_n ≤ Total number of bytes of relay link area -h_n
 - 0 ≤ b₁ ≤ Total number of bytes of register link area -i₁
 - 0 ≤ a_n ≤ Total number of bytes of register link area -i_n

- Number of receiving bytes of slave station (h_1 to h_n , i_1 to i_n)
Select self-setting or “same as number of sending bytes (c_1 to c_n , d_1 to d_n)” according to parameter (007720 to 007723) of slave station.
- Number of offset bytes can be set exceeding the number of sending bytes of the master station.
 $a_1, a_n \geq c_0$ and $b_1, b_n \geq d_0$

(3) When the master station and slave stations are all JW-20MN and both data link (the standard function) and data link ([V5] memory capacity save function) are set among slave stations.

Set signs below by the parameters of the master station and slave station (page 10·6 and 10·13).

- An example of a relay link area map for the setting of the data link (standard function) for slave station 01 and the data link (memory capacity save function) to slave station 02.

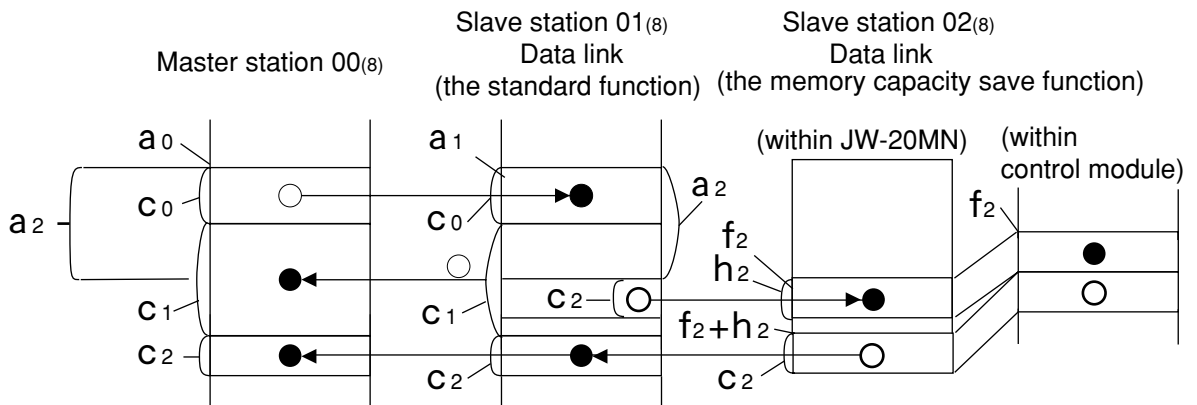

$$\left(\begin{array}{l} \text{Total number of bytes of relay link area } (C_0 + C_1 + C_2) \leq 256 \text{ bytes} \\ C_2 + h_2 \leq 64 \text{ bytes} \quad 0 \leq a_2 \leq C_0 + C_1 \end{array} \right)$$

- An example of register link area map for the setting of the data link (the memory capacity save function) to slave station 01 and 03 and data link (the standard function) to slave station 02.

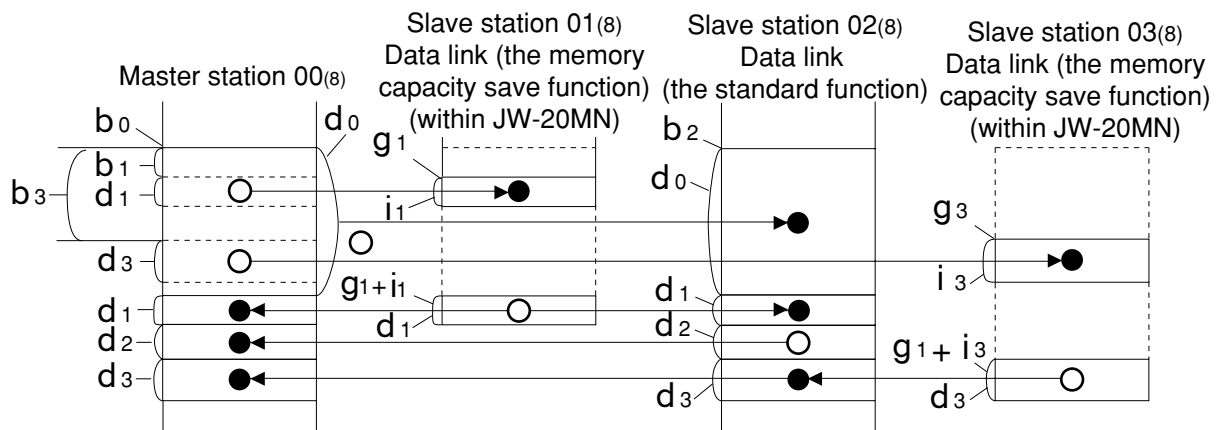

$$\left(\begin{array}{l} \text{Total number of bytes of register link area } (d_0 + d_1 + d_2 + d_3) \leq 2048 \text{ bytes} \\ 0 \leq b_1 \leq d_0 + d_2 + d_3 \quad 0 \leq b_3 \leq d_0 + d_1 + d_2 \\ i_1 + d_1 \leq 512 \quad i_3 + d_3 \leq 512 \end{array} \right)$$

[3] Setting procedure

In brackets : See page in chapter 10

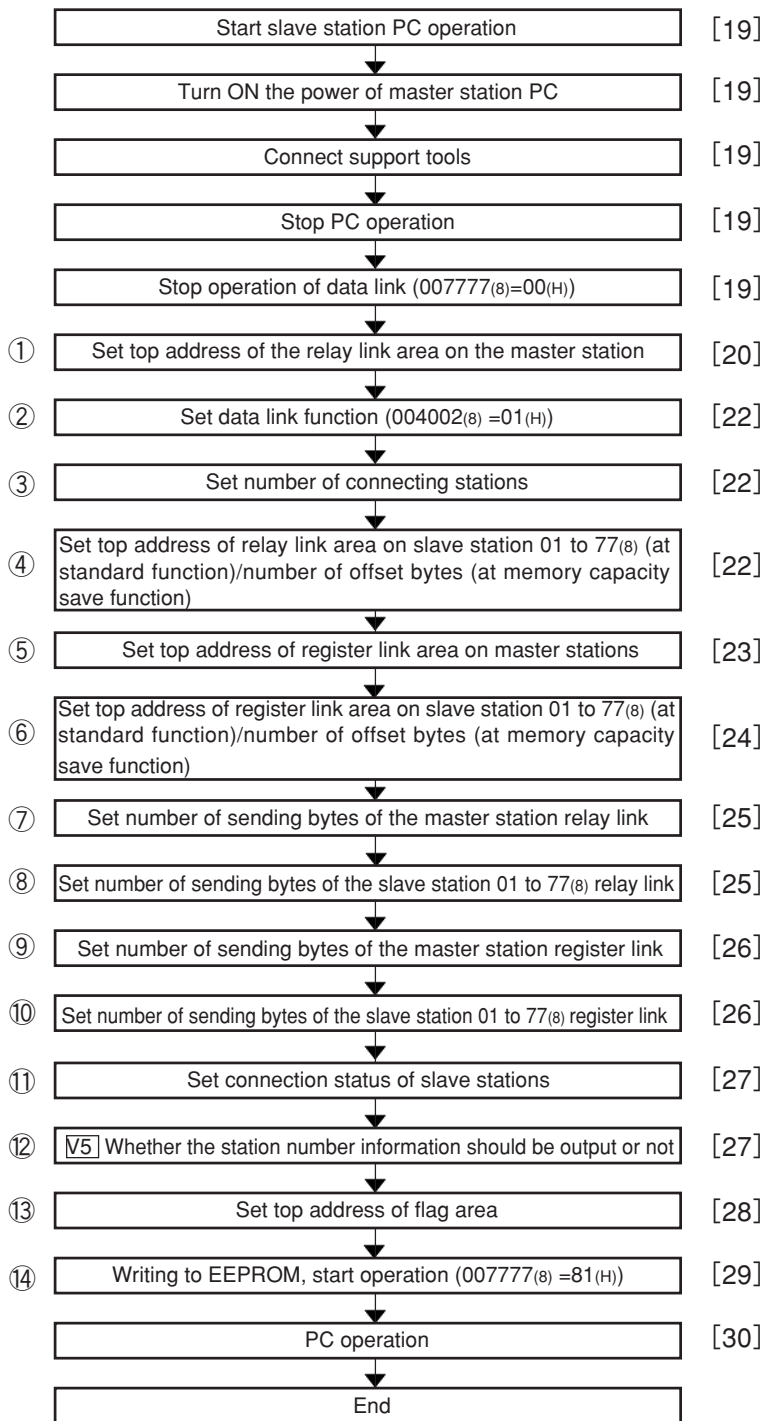

• ① to ⑭ correspond to numbers in page 10·13 and 10·14.

“Run” the slave station PC

Turn “ON” the power of the master station PC and connect support tools

- Connect a support tool with the JW-20MN and prepare the setting parameter.

<Usable support tools>

JW-13PG/12PG

JW-50SP

JW-50PG, Z-100LP2S

- For operation of each support tool, see the instruction manual attached. The following describes an example of JW-13PG’s key operation.

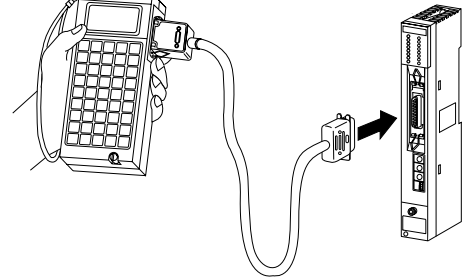

Stop PC operation

- Turn to program mode (stop PC operation). Setting of parameters is only available when the PC is in program mode.

(Operation example of JW-13PG)

*** * PROG MODE SET 8** → Stop PC operation

クリア CLR * * シフト SHIFT INTL DISP SET 8 1 → Select parameter setting mode.

— Select initial mode — (Parameter setting)

Stop operation of data link [HEX (hexadecimal), byte]

- Setting of the parameter is only available when the operation of the JW-20MN is stopped.
- Write “00_(H)” to parameter address 007777₍₈₎ and stop operation of the JW-20MN.

(Operation example of JW-13PG)

7 7 7 7 モニタ MNTR A 0 書込 ENT

Display the contents of parameter address 007777 by hexadecimal. (Write 00_(H))

Screen display of JW-13PG

07775	HEX	00
07776	HEX	00
I PARAM.		
>07777	HEX	00

Reference Function of JW-13PG

- **変換 CONV** key: Changeover unit of figures
 → HEX_(hexadecimal) → OCT_(octal) → DCM_(decimal) → Bit pattern
- **FORDE LENGTH** key: Byte display ↔ Changeover word display

To the next page

From the previous page

Set top address of the relay link area on the master station [OCT (octal), word]

- Set file address₍₈₎ to parameter address 004000 to 004001₍₈₎.
These top addresses should not overlap the register link area, flag area, or any area used by other option module. (Setting area : See page 15-11 and 15-12.)

In case of setting 00210 (file address 000210₍₈₎) using JW-13PG : Example of the next page.



_ Display the contents of address 004000₍₈₎ _ / (Word display) _ After converting to octal, _ / write the data 000210.

Screen display of JW-13PG

03774	0	000000
03776	0	000000
I PARAM.		
>04000	0	000210

To the next page

From the previous page

[Example for setting]

The master station and slave station 01 and 02 are JW-20MN.

It shows example for setting that slave station 01 is data link (standard function) and slave station 02 is data link (memory capacity save function : **[V5]**).

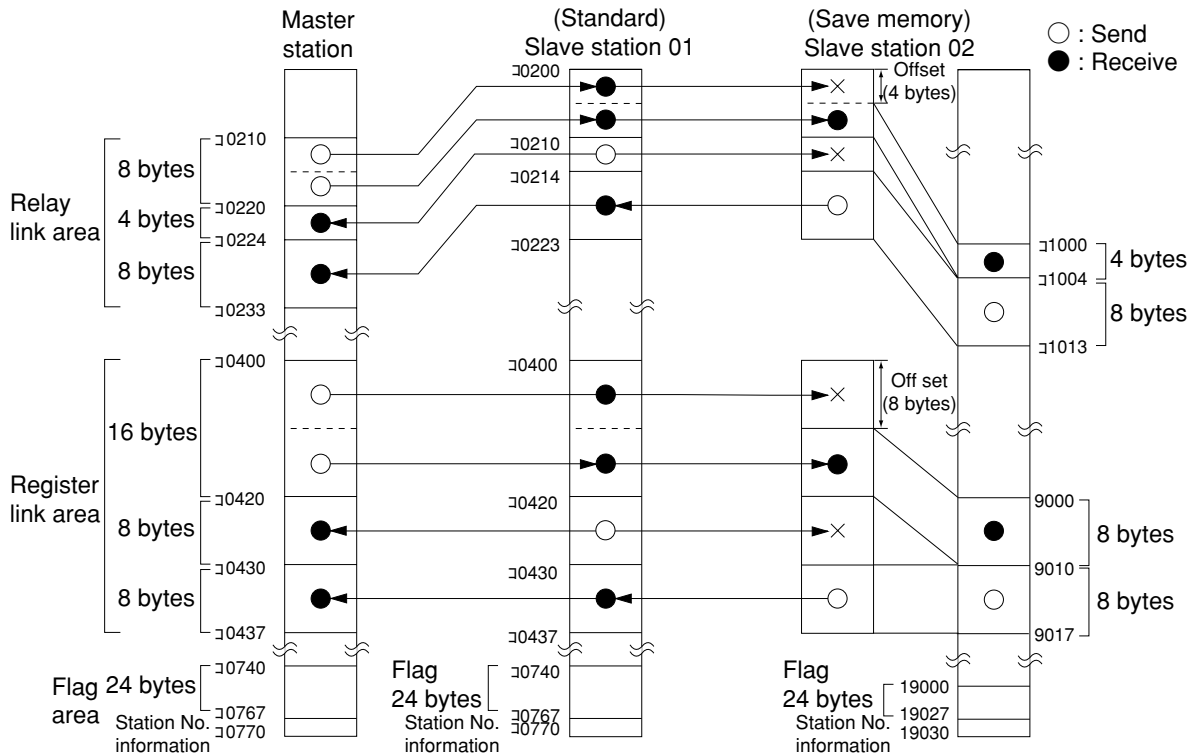

	Maser station	Slave station 1 (standard)	Slave station 2 (save memory)
Top address of relay link area	0210	0200	* 01000
Number of offset bytes of relay link area	—	—	4 bytes
Number of sending bytes of relay link	8 bytes	4 bytes	8 bytes
Number of receiving bytes of relay link	—	—	* 4 bytes
Top address of register link area	0400	0400	* 09000
Number of offset bytes of register link area	—	—	8 bytes
Number of sending bytes of register link	16 bytes	8 bytes	8 bytes
Number of receiving bytes of register link	—	—	* 8 bytes
Top address of flag area	0740	* 0740	* 19000
Station number information output	Yes	* Yes	* Yes

No mark -- Setting by parameter of master station
 * ----- Setting by parameter of slave station

To the next page

From the previous page

Data link function setting [HEX (hexadecimal), byte]

- Set "001₍₈₎" in parameter address 004002₍₈₎ and change to "relay/register link."

(Operation example of JW-13PG)

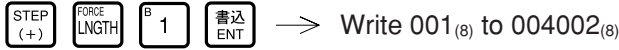

Screen display of JW-13PG

04000	OCT	210
04001	OCT	000
I PARAM.		
>04002	OCT	001

Set number of connecting stations [DCM (decimal), byte]

- Set the number of connecting stations including the master station in the parameter address 004003₍₈₎ by octal.
- If you try to set values other than 02 to 64_(D), the JW-20MN displays 6F_(H) error code.

(When to set number of connected stations to 3 using the JW-13PG.)

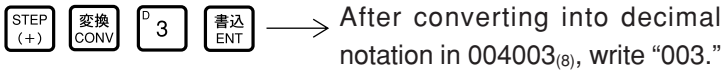

Screen display of JW-13PG

04001	DCM	000
04002	DCM	001
I PARAM.		
>04003	DCM	003

Set top address of relay link area on slave station (01 to 77₍₈₎) (at standard function)/number of offset bytes (memory capacity save function)

File address: OCT (octal), word
Number of offset bytes: DCM_(D), word
Set the "same" as or "different" from the master station: HEX (hexadecimal), bytes.

- Set in parameter addresses 004004 to 004377₍₈₎. These top addresses should not overlap the register link area, flag area, or any area used by other option module.

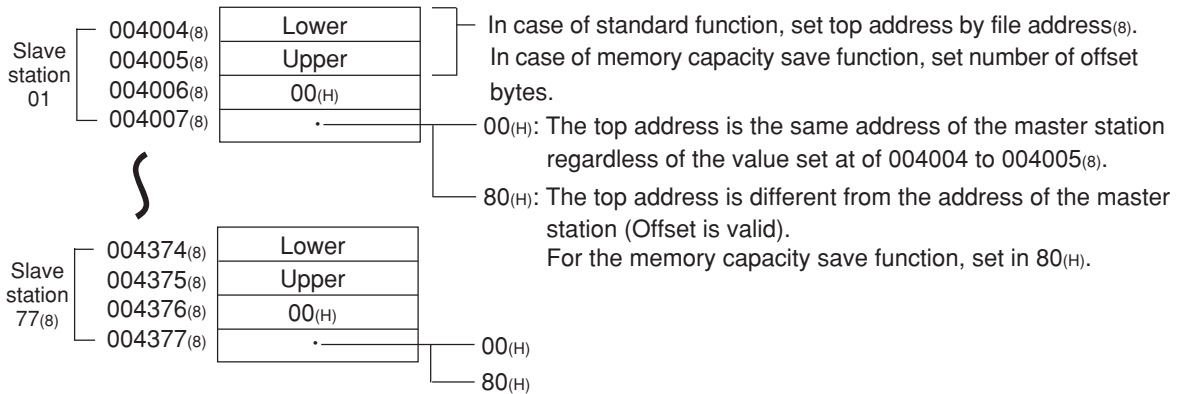

- In case of setting 0200 (file address 000200₍₈₎) in parameter addresses 004004 to 004007₍₈₎ (slave station 01) and set 4 (number of off set bytes) in 004010₍₈₎ to 004013₍₈₎ (slave station 02). (Example in the previous page.)

To the next page

From the previous page

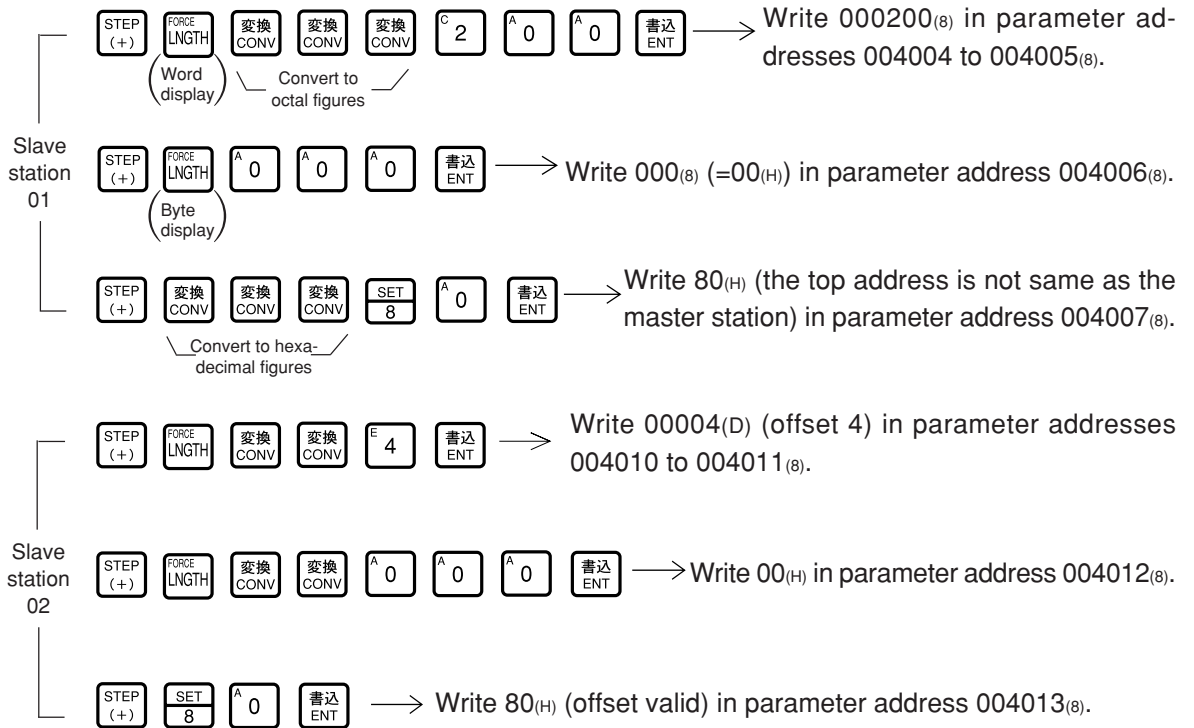

Screen display of JW-13PG

04011	HEX	00
04012	HEX	00
I PARAM.		
>04013	HEX	80

Set top address of register link area on the master station

File address: OCT (octal), word
File number: HEX (hexadecimal), bytes.

Set on the parameter address (004400 to 004403₍₈₎) in the file address₍₈₎. (Setting area : See page 15·11 and 15·12.)
 These top addresses should not overlap the register link area, flag area, or any area used by other option modules.

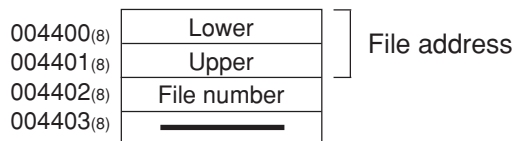

- In case of setting 00400 (file address 000400₍₈₎) in parameter addresses 004400 to 004403₍₈₎ and set 0 (file number) in 004402₍₈₎. (Example for page 10·21).

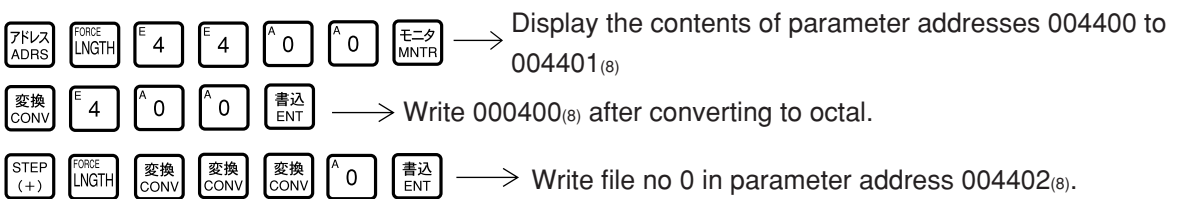

Screen display of JW-13PG

04400	OCT	00
04401	OCT	01
I PARAM.		
>04402	OCT	00

To the next page

From the previous page

**Set top address of register link area on slave station 01 to 77⁽⁸⁾ (at standard function)/
number of offset bytes (at memory capacity save function)**

**File address: OCT (octal), word
File number: HEX (hexadecimal), byte
Number of offset bytes: DCM_(D), word
Set the “same” as or “different” from the
master station: HEX (hexadecimal) , bytes.**

- Set in parameter addresses 004404 to 004777⁽⁸⁾. (Setting area : See page 15·11 and 15·12.)
These top addresses should not overlap the register link area, flag area, or any area used by other option module.

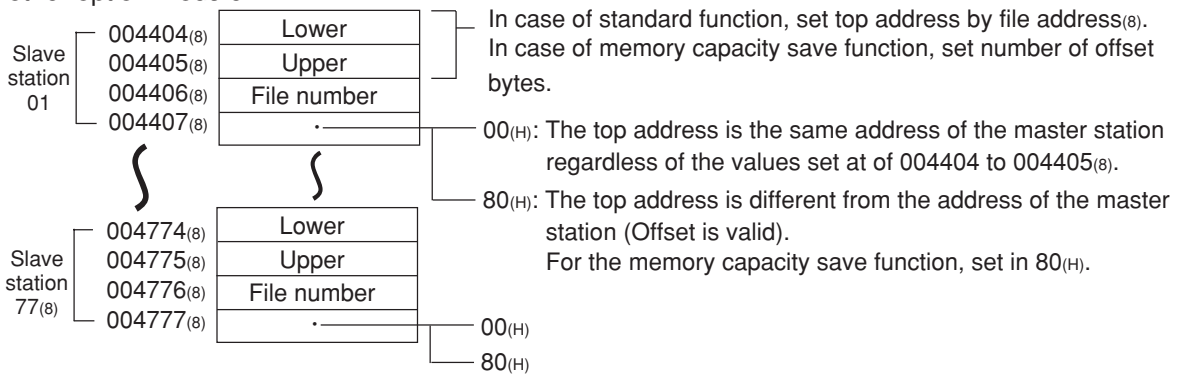

- In case of setting 0 (the top address is 30440, the same as the address of the master station) in parameter addresses 004404 to 004407⁽⁸⁾ (slave station 01) and the offset byte number 8 and “offset valid” on the parameter address 004410 to 004413⁽⁸⁾ (slave station 02). (Example for 10·21)

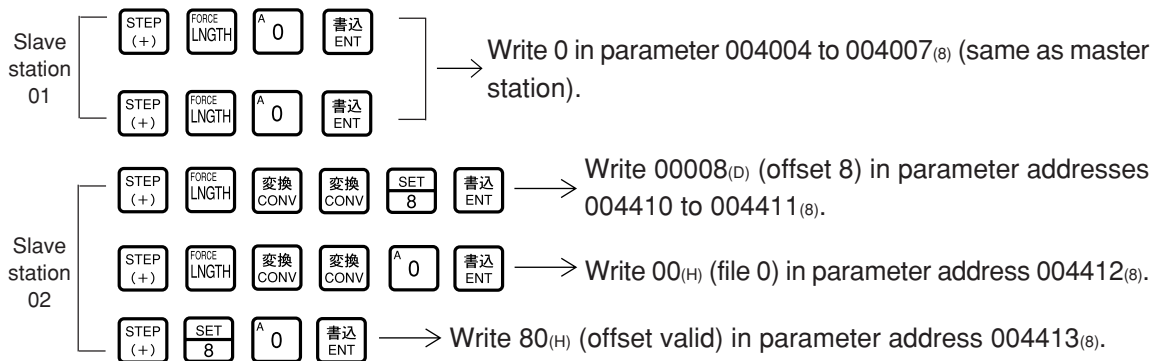

Screen display of JW-13PG

04011	HEX	00
04012	HEX	00
I PARAM.		
>04013	HEX	80

To the next page

From the previous page

Set the number of sending bytes of the master station relay link [DCM (decimal), word]

- Set in parameter addresses 005000 to 005001⁽⁸⁾.

005000 ⁽⁸⁾	Lower
005001 ⁽⁸⁾	Upper

- These top addresses should not overlap the register link area, or the flag area, or exceed the setting range (0 to 256 bytes for each station, 256 bytes for all stations in total).

In case of setting 8 bytes: Using JW-13PG example for page 10-21

アドレス (ADR) 5 0 0 0 モニタ (MNT)

→ Display the contents of parameter addresses 005000 to 005001⁽⁸⁾

変換 (CONV) 変換 (CONV) SET 8 書込 (ENT)

→ Write 00008^(D) after converting to decimal.

Screen display of JW-13PG

04774	D	00000
04776	D	00000
I PARAM.		
>05000	D	00008

Set the number of sending bytes of the slave station (01 to 77) relay link [DCM (decimal), word]

- Set the number of sending bytes in decimal on the parameter addresses 005002 to 005177⁽⁸⁾. (set in each station, 2 bytes for each station).

These top addresses should not overlap the register link area, or the flag area, or exceed the setting range (0 to 256 bytes for each station, 256 bytes for all stations in total).

Slave station 01 ⁽⁸⁾	005002 ⁽⁸⁾	Lower	} Enter by decimal
	005003 ⁽⁸⁾	Upper	
to			
Slave station 77 ⁽⁸⁾	005176 ⁽⁸⁾	Lower	} Enter by decimal
	005177 ⁽⁸⁾	Upper	

(In case of setting 4 bytes for slave station 01, and set 8 bytes for slave station 02: Example of page 10-21)

Slave station 01 STEP (+) 4 書込 (ENT)

→ Write 00004^(D) in parameter addresses 005002 to 005003⁽⁸⁾.

Slave station 02 STEP (+) SET 8 書込 (ENT)

→ Write 00008^(D) in parameter addresses 005004 to 005005⁽⁸⁾.

Screen display of JW-13PG

05000	D	00008
05002	D	00004
I PARAM.		
>05004	D	00008

To the next page

From the previous page

Set the number of sending bytes of the master station register link [DCM (decimal), word]

- Set the number of sending bytes in decimal on the parameter addresses 005200 to 005201⁽⁸⁾.
- These top addresses should not overlap the relay link area or the flag area, or exceed the setting value (0 to 2048 bytes for each station, 2048 bytes for all stations in total).

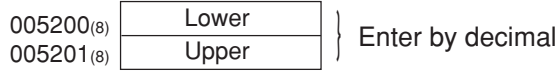

(In case of setting 16 bytes using JW-13PG: Example of page 10·21)

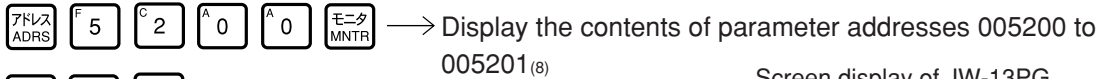

Screen display of JW-13PG

05174	D	00000
05176	D	00000
I PARAM.		
>05200	D	00016

Set the number of sending bytes of the slave station (01 to 77⁽⁸⁾) register link [DCM (decimal), word]

- Set the number of sending bytes in decimal on the parameter addresses 005202 to 005377⁽⁸⁾. (set in each station, 2 bytes for each station).
- These top addresses should not overlap the register link area, or the flag area, or exceed the setting range (0 to 2048 bytes for each station, 2048 bytes for all stations in total).

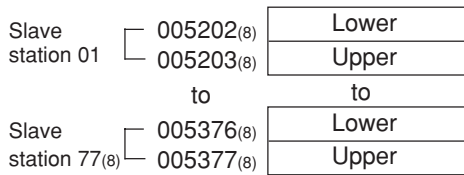

(In case of setting 8 bytes both for slave station 01 and 02: example of page 10·21)

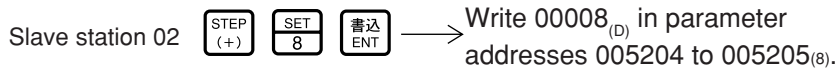
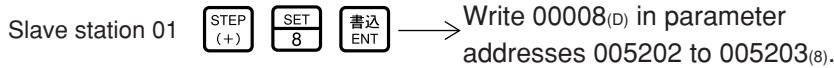

Screen display of JW-13PG

05200	D	00016
05202	D	00008
I PARAM.		
>05204	D	00008

To the next page

From the previous page

Set connection status of slave station [Bit pattern, byte]

- In the initial settings of the data link function, the JW-20MN will not display errors (on the LEDs on the panel, or in the system memory) even if it detects a communication error in a slave station. In order to display the error when a slave station communication error is detected, set bit 0(E) at parameter address 007750⁽⁸⁾ to ON. Each bit at addresses 00751 to 007757⁽⁸⁾ corresponds to a slave station. Turn ON the respective bit if required. (See page 15-10.)

With the setting above, the JW-20MN will display errors when a slave station whose corresponding bit is ON produces a communication error.

Ex.: Setting the bits to output errors for slave stations 01 and 02 using the JW-13PG.

007750 ⁽⁸⁾	7	6	5	4	3	2	1	0
	0	0	0	0	0	1	1	1

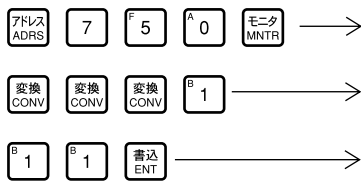

Screen display of JW-13PG

0 7 7 4 6	□□□□□□□□
0 7 7 4 7	□□□□□□□□
I PARAM.	
> 0 7 7 5 0	□□□□□■

- When the JW-20MN is set to “Turn OFF a bit correspond to the slave station number,” its slave station error code will not be displayed on the indicator lamp.

V5 Set whether the station number information should be output or not

- Set whether the station number information should be output or not on the parameter address 007763⁽⁸⁾.

007763⁽⁸⁾ Whether the station number information should be output or not

- 00(H) : Do not output
- 01(H) : Output

The station number information is output on the next byte of the flag area (24 bytes.)

To the next page

From the previous page

Set top address of flag area

File address: OCT (octal), word
File number/flag: HEX (hexadecimal), byte

- Set the top address of the flag area (24 bytes) in order to monitor the communication condition and PC operation condition on the parameter address 007764 to 007767₍₈₎. (See page 15·11 and 15·12 for setting range)
- Flag area uses 24 bytes regardless number of connecting stations.

	Contents	Initial value	
007764 ₍₈₎	Lower	E0 _(H)	} 01E0 _(H) → 000740 ₍₈₎ → 0740
007765 ₍₈₎	Upper	01 _(H)	
007766 ₍₈₎	File number	00 _(H)	File number 0
007767 ₍₈₎	D7	80 _(H)	Output flag

Output flag : ON
 Do not output flag : OFF

- In case of setting “0740, output flag” using JW-13PG.

アドレス (ADRS) 7 7 6 E 4 モニタ (MNTR) 変換 (CONV) 変換 (CONV) FORCE (LNGTH) 7 E 4 ^ 0 書込 (ENT)

Write “740(0740)” in parameter addresses 007764 to 007765₍₈₎.

STEP (+) FORCE (LNGTH) 変換 (CONV) 変換 (CONV) 変換 (CONV) ^ 0 書込 (ENT)

After switching to byte display, write file No. 0 with HEX (hexadecimal)

STEP (+) SET 8 ^ 0 書込 (ENT)

Write 80_(H) to address 007767₍₈₎

Screen display of JW-13PG

07765	HEX	01
07766	HEX	00
I PARAM.		
>07767	HEX	80

To the next page

From the previous page

Writing to the EEPROM of the JW-20MN, start operation [HEX (hexadecimal), byte]

- Write “81_(H)” into parameter address 007777₍₈₎ and write the set parameter contents into the EEPROM of the JW-20MN.
- Then start the JW-20MN. After starting operation, the setting value changes to “01_(H).”

Setting value _(H)	Contents
0 0	Stop operation of the JW-20MN
0 1	Start operation of the JW-20MN
8 0	Writing to the EEPROM of the JW-20MN, stop operation
8 1	Writing to the EEPROM of the JW-20MN, start operation
0 8	Initialize parameters

(Operation example of JW-13PG)

Display the contents of address 007777₍₈₎
 Write 81_(H)

Screen display of JW-13PG

07765	HEX	01
07766	HEX	00
I PARAM.		
>07767	HEX	80

Remarks

- Writing time to EEPROM is approximately 0.7 sec. When any error is found for parameter settings, the JW-20MN lights the error code (6F_(H)) by the indication lamp.
- Treatment when error code 6F_(H) appears and COMM is turned OFF.
 - ① Check number of top addresses/bytes of master station “relay link” and “register link.”
 - ② Check the set value for number of connected stations.
 - ③ Check the set value for master station flag top address.
 - ④ Check whether the function is set to “relay register link.”
- Written contents into the EEPROM are automatically written to the RAM of the JW-20MN when turning ON the power of the PC. At reading, the PC checks BCC and compares BCC check code of the parameter memory address (007776₍₈₎). When an error is found, the JW-20MN lights the error code (6E_(H)) by the indication lamp.
- If “parameter initialization” is selected, the module initializes parameter addresses 004000 to 007776₍₈₎.

To the next page

From the previous page



PC operation

Turning a master module to monitor or change mode (PC operation).
(Operation example of JW-13PG)

Screen display of JW-13PG

* * MNTR MODE SET 8 → Monitor mode

* * MNTR MODE SET 8 → Change mode

```
C00000  
>
```

Chapter 11: Error and Treatment

Operation status of the JW-20MN can be check by indication lamps, flags, or system memory.

11-1 Indicator lamp

Name	Operation	Recovery
COMM	Lights while the operating data link	_____
SD	Flickers while sending data	_____
RD	Flickers while receiving data	_____
CD	Flickers while detecting a carrier	_____
LT	Lights when the termination resistance switches turned ON	_____
TEST	Lights while testing	_____
COM.E	Lights while an error is detected (Indicate error code by S0 to S7 LEDs)	<ul style="list-style-type: none"> · Check disconnection of communication cable · Check settings of switches · Check settings of parameter · Check power supply voltage.
FAULT	Lights when the watchdog timer is time up (JW-20MN is faulty)	Replace the JW-20MN
S0 to S7	Indicates error codes by hexadecimal when an error is occurred	See the next page.

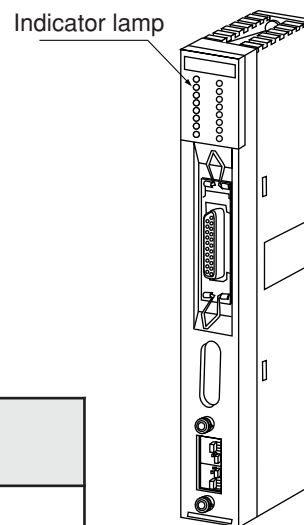
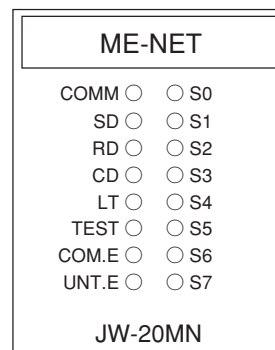

(Error code) Error codes are expressed with bit patterns from S0 to S7.

Error code (HEX)	Cause	Measure
01	ROM error, upper CPU	Replace the JW-20MN
02	RAM error, upper CPU	
03	2 port RAM error against PC, upper CPU	
04	2 port RAM error against communication CPU, upper CPU	
11	ROM error, communication CPU	<ul style="list-style-type: none"> · Check the communication cable · Check for doubled allocation of slave station number · Replace the JW-20MN
12	RAM error, communication CPU	
18	Communication LSI error, communication CPU	
1F	No response, communication CPU	Check the parameter setting
20	More than one token detected	
21	Doubled address detected	Replace the JW-20MN
22	Fault of sending section	
23	Token does not return within the rated interval	Check the communication cable
2A	Overflow of receiving buffer. Occurs when the upper CPU processing is delayed.	Check the communication cable
2B	Frame length error	
2C	Media error	
30	EEPROM error	Replace the JW-20MN
*6E	BCC error	Check the parameter contents
6F	Parameter setting error	
C1 to *FF	Communication error <ul style="list-style-type: none"> · After converting into octal, the lower two digits represent the slave station number of the current error. (EX. C1_(H)=301_(B)= slave station 01) 	Check the communication cable and slave module

* Error codes 6E_(H) and C1 to FF_(H) are special error codes used only by the JW-20MN. Other error codes are specified by the ME-NET specifications.

11-2 Flag

Flag area is 24 bytes from the “flag top address” set in the master station/slave station parameters.

(1) Flag table [In case of flag top address is 30740 (initial value)]

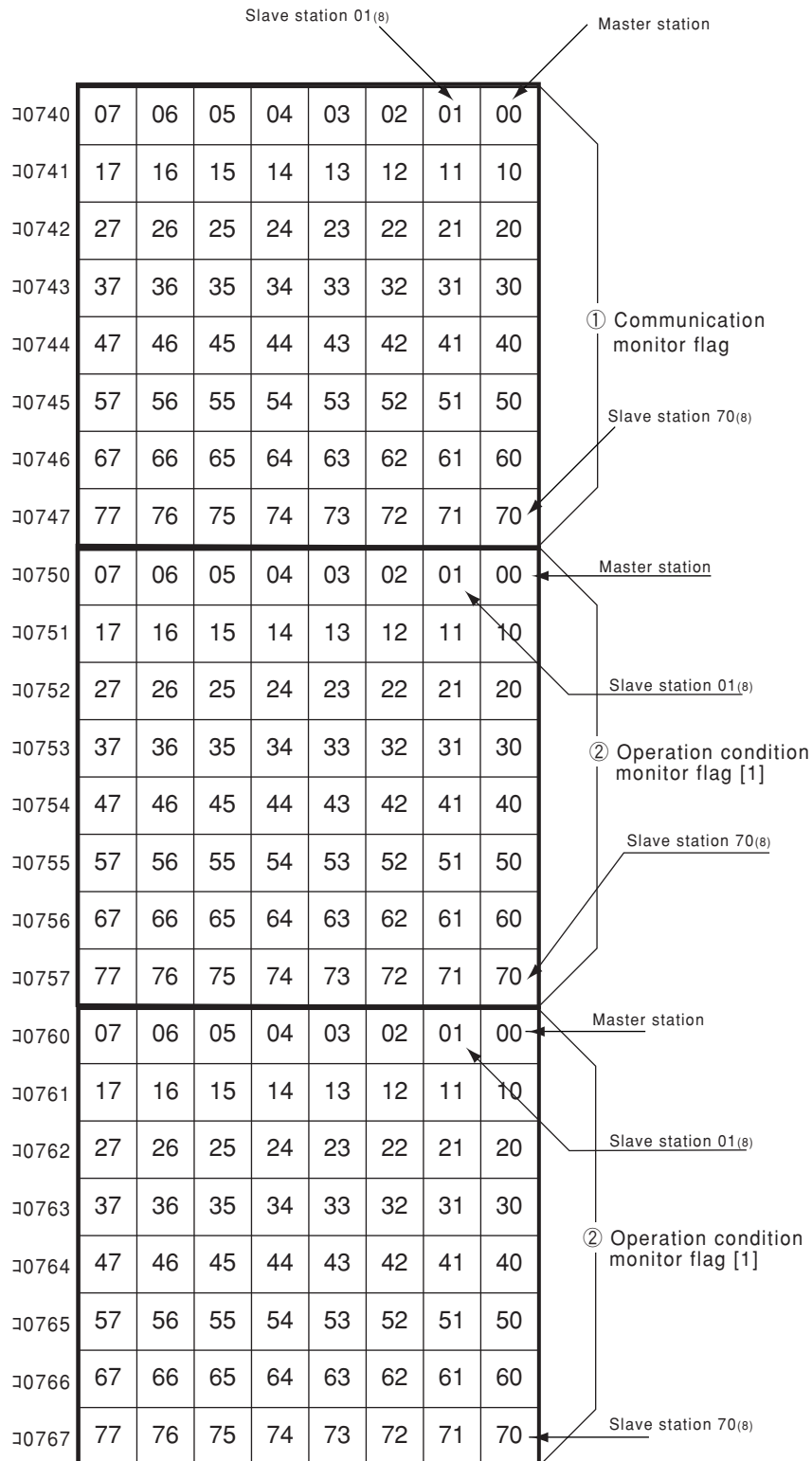

Remarks

- Even a slave station can monitor 24 bytes of flag.

(2) In the case of a master station 00₍₈₎

① Communication monitor flag

This flag is used to monitor the communication condition with other stations. Non-connected station keeps this flag as “OFF.”

Flag	Condition for flag operation	Flag operation
Own station flag (master station)	When the parameter address 007777 ₍₈₎ of the master station is set to “01 _(H) ” and the master station is operating normally.	ON
	When the parameter address 007777 ₍₈₎ of the master station is set to “00 _(H) ” Improper setting of parameter, BCC check error, or other errors.	OFF

Flag	Condition for flag operation	Flag operation	
Other station's flag (01 to 77)	Normal communication with slave stations.	ON	Specific slave station
	Stopped communication or unable to communicate with slave stations.	OFF	
	Communication monitor flag ① of the master station is turned “OFF.”		All slave stations

The master station periodically executes communication recovery operation with the communication error slave station. When the error situation is recovered, the master station returns to normal communication.

② Operation condition monitor flag [1]

This flag is used to monitor the operation condition of slave stations when the communication with each slave station is normal.

Non-connected station keeps this flag as “OFF.”

Flag	Condition for flag operation	Flag operation
Own station flag (master station)	Communication monitor flag ① of the master station is turned “ON.”	*ON
	Communication monitor flag ① of the master station is turned “OFF.”	OFF

Flag	Condition for flag operation	Flag operation	
Other station's flag (01 to 77)	Slave station is operating.	ON	Specific slave station
	Slave station stops operation (not by an error cause).	OFF	
	Communication monitor flag ① of the master station is turned “OFF.”		All slave stations
	Slave station that communication monitor flag ① is turned to “OFF.”	Not specified	

* Even if a master station PC has stopped operation normally or by an error, the JW-20MN turns “ON” this flag while communicating.

③ Operation condition monitor flag [2]

This flag is used to monitor the abnormal stop of each slave station when the communication with each slave station is normal.

Non-connected station keeps this flag as "OFF."

Flag	Condition for flag operation	Flag operation
Own station flag (master station)	Communication monitor flag ① of the master station is turned "ON."	*ON
	Communication monitor flag ① of the master station is turned "OFF."	OFF

Flag	Condition for flag operation	Flag operation	
Other station's flag (01 to 77)	Each slave station is normal.	ON	Specific slave station
	Any of the slave stations is faulty (caused to be stopped abnormally).	OFF	
	Communication monitor flag ① of the master station is turned "OFF."		All slave stations
	Slave station that communication monitor flag ① is turned to "OFF."	Not specified	

* Even if a master station PC has stopped operation normally or by an error, the JW-20MN turns "ON" this flag while communicating.

[3] In the case of slave station 01 to 77⁽⁸⁾

① Communication monitor flag

This flag is used to monitor the communication condition with other stations. Non-connected station keeps this flag as "OFF."

Flag	Condition for flag operation	Flag operation
Own station flag	When the parameter address 007777 ⁽⁸⁾ of each slave station is set to "01 ^(H) ," and at communicating with a master station normally.	ON
	When the parameter address 007777 ⁽⁸⁾ of each slave station is "00 ^(H) ."	OFF
	When link start switch "00 ^(H) " of the master station is OFF.	

Flag	Condition for flag operation	Flag operation	
Other station's flag	Normal communication with each station.	ON	Specific station
	Stopped communication or unable to communication with each station.	OFF	
	Communication monitor flag ① of the master station is turned "OFF."		All stations

② Operation condition monitor flag [1]

This flag is used to monitor the operation condition of each station when the communication with each station is normal.

Non-connected station keeps this flag as "OFF."

Flag	Condition for flag operation	Flag operation
Own station flag	Communication monitor flag ① of the own station is turned "ON."	*ON
	Communication monitor flag ① of the own station is turned "OFF."	OFF

Flag	Condition for flag operation	Flag operation	
Other station's flag	Each station is operating.	ON	Specific station
	Each station stops operation (not by an error cause).	OFF	
	Communication monitor flag ① of the own station is turned "OFF."		All slave stations
	Slave station that communication monitor flag ① is turned to "OFF."	Not specified	

* Even if the own station PC has stopped operation normally or by an error, the JW-20MN turns "ON" this flag while communicating.

③ Operation condition monitor flag [2]

This flag is used to monitor the abnormal stop of each station when the communication with each station is normal.

Non-connected station keeps this flag as "OFF."

Flag	Condition for flag operation	Flag operation
Own station flag	Communication monitor flag ① of the own station is turned "ON."	*ON
	Communication monitor flag ① of the own station is turned "OFF."	OFF

Flag	Condition for flag operation	Flag operation	
Other station's flag	Each station is normal.	ON	Specific station
	Any of the stations is faulty (caused to be stopped abnormally).	OFF	
	Communication monitor flag ① of the own station is turned "OFF."		All stations
	Slave station that communication monitor flag ① is turned to "OFF."	Not specified	

* Even if a own station PC has stopped operation normally or by an error, the JW-20MN turns "ON" this flag while communicating.

(4) Monitor operation condition by each station PC

By creating a program having the flags shown below in each station's PC, the JW-20MN can monitor the operation condition of each station's PC.

[Example] In this case the flag top address is 30740

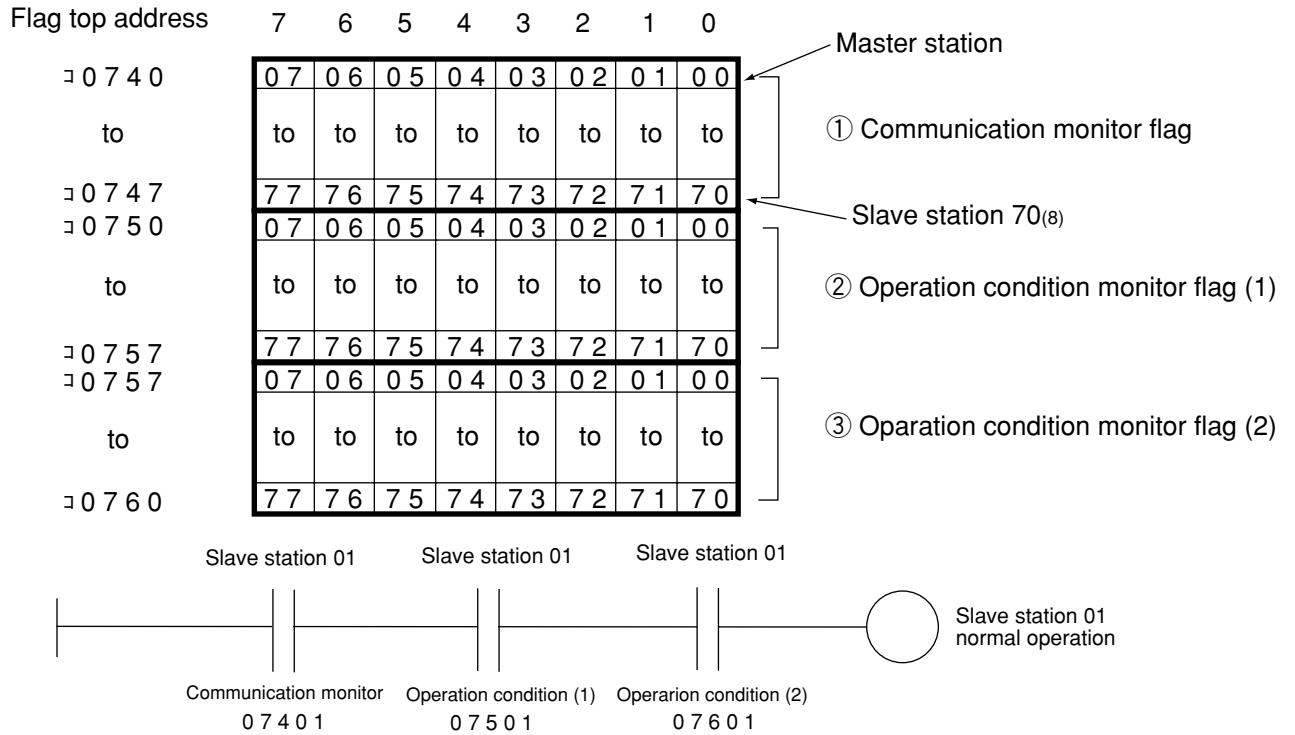

11-3 Storage of error code

When an error occurs in the JW-20MN, it stores the occurred error's code to system memory #160 and #170 of each station's PC.

Error code (HEX)	Cause	Error code stored to system memory		Measure
		#160	#170 to #177	
01	ROM error, upper CPU	53 ^(H)	_____	Replace the JW-22MN <ul style="list-style-type: none"> • Check the communication cable • Check for doubled allocation of station number • Replace the JW-20MN
02	RAM error, upper CPU			
03	2 port RAM error against PC, upper CPU			
04	2 port RAM error against communication CPU, upper CPU			
11	ROM error, communication CPU			
12	RAM error, communication CPU			
18	Communication LSI error, communication CPU			
1F	No response	_____	1F ^(H)	
20	More than one token detected	_____	20 ^(H)	Check the parameter setting
21	Doubled address detected	_____	21 ^(H)	
22	Fault of sending section	_____	22 ^(H)	Replace the JW-20MN
23	Token does not return within the rated interval	_____	23 ^(H)	Check the communication cable
2A	Over flow of receiving buffer. Occurs when the upper CPU processing is delayed.	_____	2A ^(H)	
2B	Flame length error	_____	2B ^(H)	
2C	Media error	_____	2C ^(H)	
30	EEPROM error	_____	30 ^(H)	Replace the JW-20MN
6E	BCC error	_____	6E ^(H)	Check the parameter setting
6F	Parameter setting error	_____	6F ^(H)	
C1 to FF	Communication error · After converting into octals, the lower two digits represent the slave station number of the current error. (Ex. C1 ^(H) = 301 ⁽⁸⁾ = slave station 01)	_____	C1 ^(H) to FF ^(H)	Check the communication cable and slave module

- In some cases, error code 23^(H) or 2A^(H) is stored when inputting power. This is not an error.
- Error codes 6E^(H) and C1 to FF^(H) are special error codes used only by the JW-20MN. Other error codes are specified by the ME-NET specifications.

Remarks

- The error code stored in the system memory #170 is shifted to #170 to #177 one after the other as new errors occur. Thus, the system memory can store up to 8 errors. When the PC is operating by RAM, these error codes do not disappear even after turning OFF the power. The contents of system memory #170 to #177 are kept storing after the JW-20MN recovers from the error.

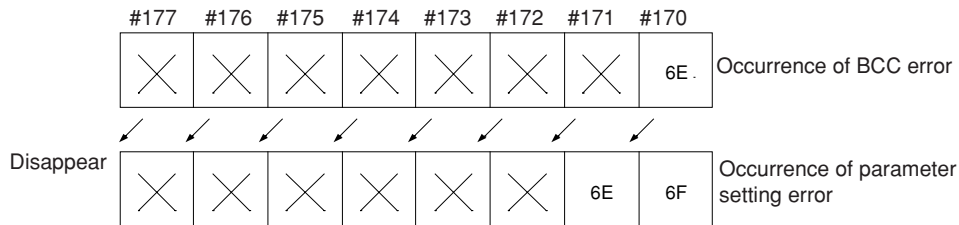

- When any of errors "01_(H)" to "18_(H)" occurs among the error codes listed on the previous page, the JW-20MN stores error code "53_(H)" (optional error) in the system memory #160. It does not store any error code in system memory #170.
- In the case of an option error "53," when you monitor system memory #050, the bit of error option module switches ON. When more than 1 bit is error, these bits switch ON. The each ON bit becomes OFF by recovering from the error condition. But the last ON bit does not become OFF even if the error condition recovers.

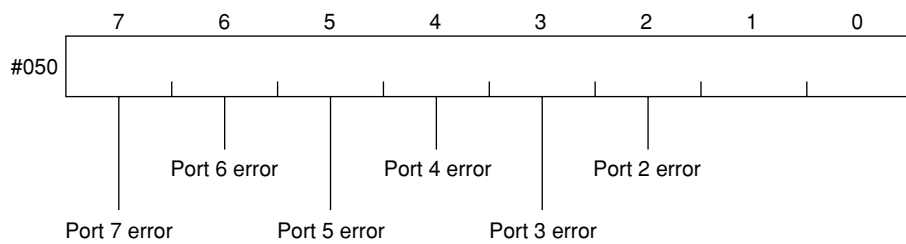

- The option slot port numbers are assigned in the order 2, 3, 4, 5, 6, 7, and so on, starting from the position closet to the control module.

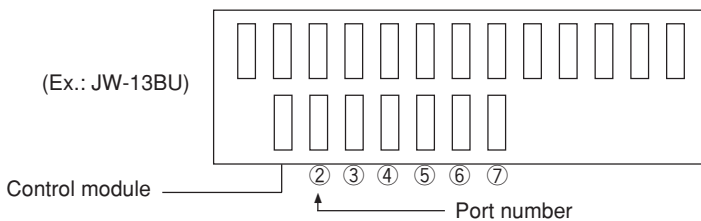

Chapter 12: Replacement of the JW-20MN

When you want to change the JW-20MN due to an operation fault (lighting UNT · E lamp) etc., follow the procedures below.

(**Make sure to store the set parameters onto a floppy diskette using a support tools.** (See the next page))

Operation procedure

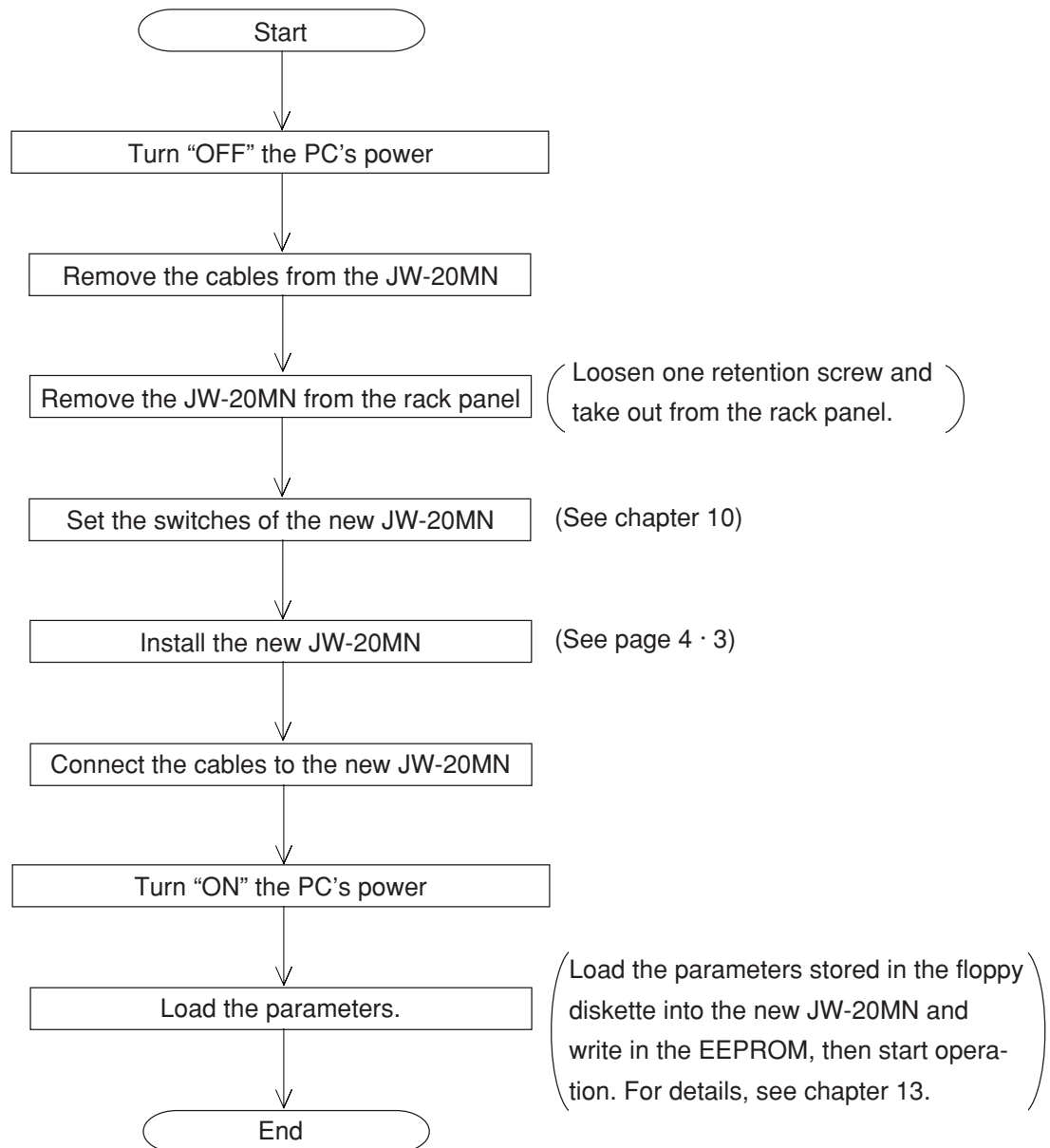

Chapter 13: Register and Load Parameters

The following support tools are available to record (store), and load the contents of the parameter memory. (Make sure to save the set parameters onto a floppy diskette for backup.)

Model name	Applicable floppy diskettes
Ladder software (JW-50SP)	3.5-inch 2DD/2HD, 5-inch 2DD/2HD
Multipurpose programmer (JW-50PG)	3.5-inch 2DD
Ladder processor II (Z-100LP2S)	3.5-inch 2DD

• Record and load using ladder software (JW-50SP)

(1) Record

① Stop operation of the JW-20MN

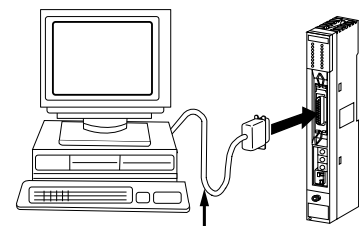
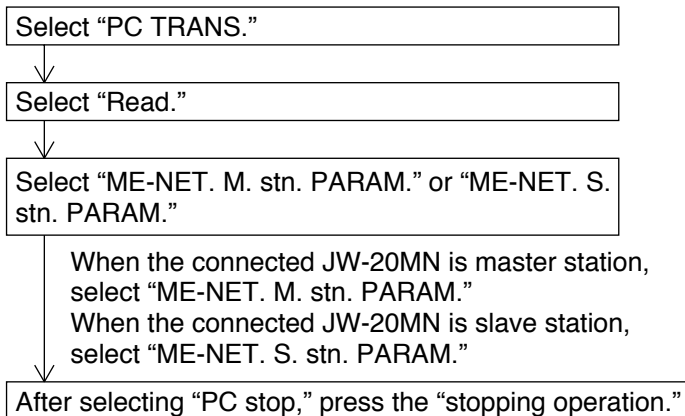

- JW-50SP with a communication adaptor and a 9-pin/25-pin conversion connector
- Control module connection cable

② Record onto a personal computer

After stopping operation, record the parameters of the JW-20MN onto the memory of the personal computer.

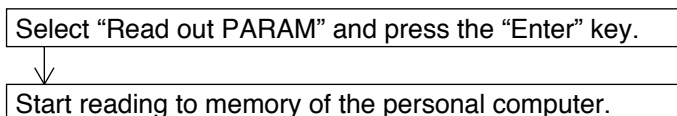

③ Start operation of the JW-20MN

After recording the parameters onto the personal computer, start operation of the JW-20MN.

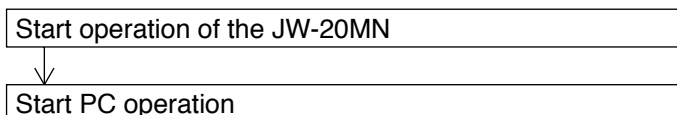

④ **Record onto a floppy diskette**

Write (record) the memory contents of the personal computer onto a floppy diskette.

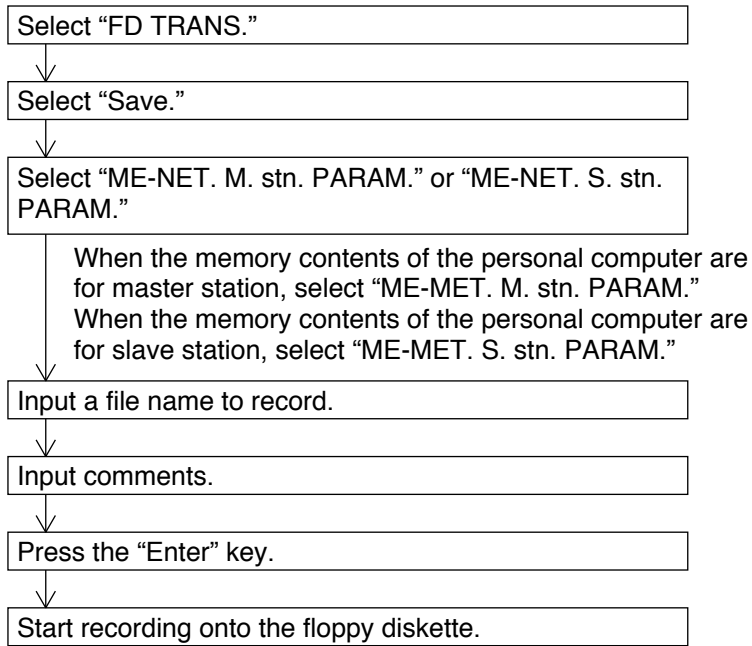

(2) Load

① Load to the personal computer

Load the contents of the floppy diskette into the memory of the personal computer.

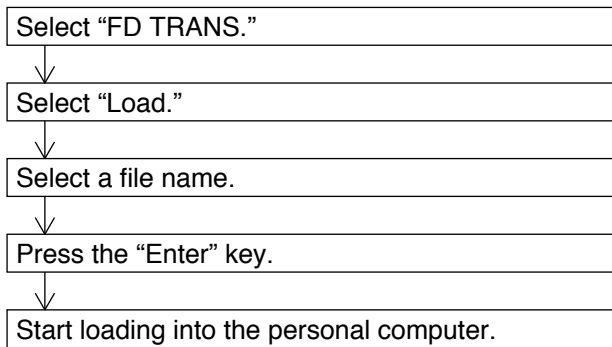

② Stop operation of the JW-20MN

After stopping operation, load the memory contents of the personal computer into the JW-20MN.

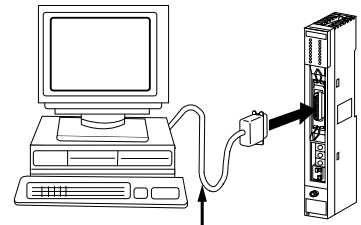
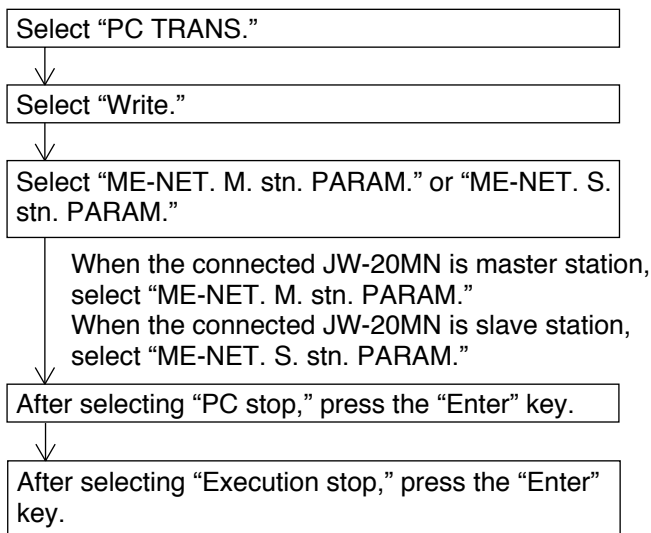

- JW-50SP with a communication adaptor and a 9-pin/25-pin conversion connector
- Control module connection cable

③ **Load to the JW-20MN**

After stopping operation, load the memory contents of the personal computer into the JW-20MN.

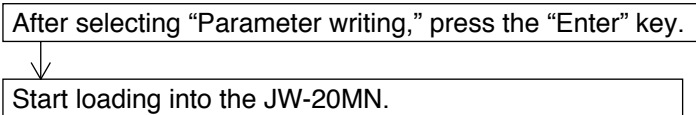

④ **Start operation of the JW-20MN**

After loading the parameters from the personal computer, start operation of the JW-20MN.

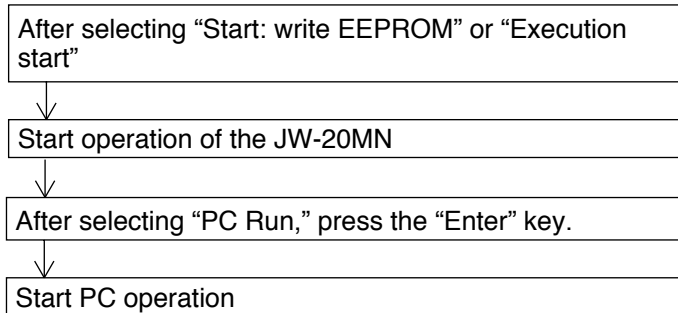

Chapter 14: Specifications

14-1 General specifications

Item	Specification
Storage temperature	-20 to +70°C
Ambient temperature	0 to +55°C
Ambient humidity	35 to 90%RH (without moisture condensation)
Vibration resistance	JIS-C-0911 equivalent (X, Y, Z, 2 hours each)
Shock resistance	JIS-C-0912 equivalent
Internal power consumption	600mA (DC5V)
Weight	Approx. 520g
Accessory	One instruction manual
Optional component	Optional cable (for two options) · · · · · ZW-2CC Optional cable (for four options) · · · · · ZW-4CC Optional cable (for six options) · · · · · ZW-6CC

[Outside dimensional drawings]

(Unit: mm)

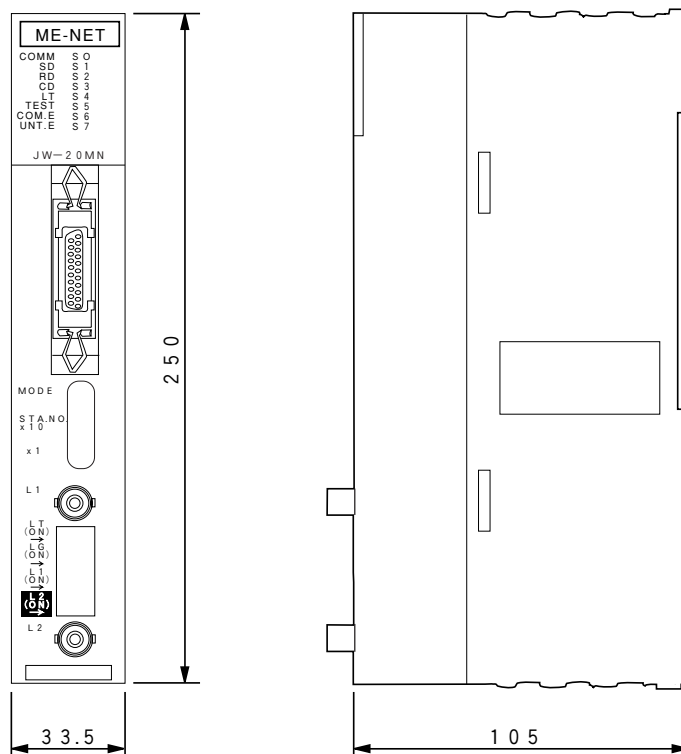

14-2 Communication specifications

Item	Specification
Communication method	Token/passing
Transmission rate	1.25M bits/s
Transmission format	JIS X-5014 high level data link control procedure (HDLC) frame configuration compatible
Coding method	NRZI (Non Return To Zero Inverted)
Check method	CRC
Synchronous method	Bit synchronous
Modulation method	Continuous frequency phase modulation (FSK)
Connectors	Module side: BNC receptacle (jack) Line side : BNC plug
Transmission line	Coaxial cable : 5C-2V (JIS· C-3501) Characteristics impedance: 75 ohm Total cable distance : 1km max.

· Data link specifications

Item		Specification	
		Relay link	Register link
No. of data link stations		64 sets max.	
Link area		File 0 (000000 ₍₈₎ to 007777 ₍₈₎)	File 0 (000000 ₍₈₎ to 015777 ₍₈₎) File 1 to 7 (000000 ₍₈₎ to 177777 ₍₈₎)
Total No. of link points		2048 points max. (256 bytes)	2048 bytes max.
Total No. of sending/rec- eiving points per slave station	Standard function	1024 bytes max in total of link relays and register link.	
	Memory capacity save function	64 points max.	512 points max.
Communication mode		N: M communication	

· Computer link specifications

Item	Specification
Number of link stations	64 stations max.
Communication data size	Maximum 1024 bytes per command
Communication control	According to the host computer command
Control functions	Data memory read/write Program memory read/write PC control Expansion function using the optional commands

Chapter 15: Appendix

15-1 Maintenance and check

Check wiring, installation, and switch settings.

Check item		System configuration				
		()	()	()	()	()
Communication cable	Not parallel with or proximate to high voltage lines or strong power lines.					
	Branch lines (drop cable) are within 400 mm.					
	Total length is less than 1 km.					
	No damage or breaks in cables.					
	Connectors are securely assembled.					
	Connectors are securely connected and locked.					
	Insulation covers are put on connectors.					
Power supply module	Securely tighten the module retention screws.					
	A ground line is connected with the GND terminal.					
Control module	Securely tighten the module retention screws.					
	Memory module is appropriately installed.					
I/O module	Securely tighten the module retention screws.					
	No other cables than the communication cable and DC input cables are input in the same duct.					
Basic rack panel is appropriately installed						
JW-20MN	Securely tighten the module retention screws.					
	Mode switches are appropriately set.					
	Station number switches are appropriately set (00 to 77 ⁽⁸⁾).					
	Termination resistance switches are appropriately set.	ON				
	Shield ground switches are appropriately set.					
	Setting of L1 (communication line 1) is the same for all stations.					
	Setting of L2 (communication line 1) is the same for all stations.					
	Parameters are appropriately set.					

15-2 Recovery method at communication errors

The method used to check and recover from errors, varies with the conditions in which the communication error occurred.

(1) During initial communication (start-up of the system)

① Lighting error code 6F^(H)

- When the master station indicates error code 6F^(H) and the COMM lamp is OFF. The cause may be a parameter setting error of the master station. Check the master station parameters below.

Parameter address ⁽⁸⁾	Contents	Setting range
004000 ⁽⁸⁾ to 004001 ⁽⁸⁾	Relay link top address of master station	See page 10·13 and 10·14
004003 ⁽⁸⁾	The number of connectable stations	
004400 ⁽⁸⁾ to 004402 ⁽⁸⁾	Register link top address of master station	
005000 ⁽⁸⁾ to 005177 ⁽⁸⁾	The number of relay link sending bytes of each station	
005200 ⁽⁸⁾ to 005377 ⁽⁸⁾	The number of register link sending bytes of each station	
007764 ⁽⁸⁾ to 007767 ⁽⁸⁾	Flag top address	

- When the master station indicates error code 6F^(H) and the COMM lamp lights. The cause may be a setting error of any of the slave stations which are set in the parameter. Check the following master station parameters.

Parameter address ⁽⁸⁾	Contents	Setting range
004004 ⁽⁸⁾ to 004377 ⁽⁸⁾	Relay link top address of slave station	See page 10·13 and 10·14
	Relay link offset bytes of slave station	
004404 ⁽⁸⁾ to 004777 ⁽⁸⁾	Register link top address of slave station	
005000 ⁽⁸⁾ to 005177 ⁽⁸⁾	Number of relay link top address sending bytes of each station	
005200 ⁽⁸⁾ to 005377 ⁽⁸⁾	Number of register link sending bytes of each station	

- When slave station is a communication module of other brand than Sharp, set appropriate in accordance with the specified set range of each module.

- When the master station is normal and the error code 6F_(H) of a slave station lights. The cause may be a faulty setting of the slave station parameter. Check the following slave station parameters.

Parameter address ₍₈₎	Contents	Setting range
007720, 007721 ₍₈₎	Number of relay link receiving bytes of slave station	See page 10· 6
007722, 007723 ₍₈₎	Number of register link receiving bytes of slave station	
007730 to 007733 ₍₈₎	Relay link top address of slave station	
007734 to 007737 ₍₈₎	Register link top address of slave station	
007764 to 007767 ₍₈₎	Flag top address	

* In case of using memory capacity save function

② When the COMM lamp of the master station is OFF (SD,RD,CD are flickering).

Check the following master station's parameters.

Parameter address ₍₈₎	Contents	Setting value
004002 ₍₈₎	Function (relay/register link)	01 _(H)
007777 ₍₈₎	Start/stop operation of the JW20MN	01 _(H)

③ Other cases

- Check optional cable of PC (The JW-20MN does not operate normally without an optional cable.)
- Check error code (See page 11·1)
- Check switches of the JW-20MN

[Switches required check in the JW-20MN]

- ① Station number (STA NO.)
- ② Mode switch (MODE)
- ③ Line changeover switches (L1/L2)
- ④ Termination resistance switch (LT)
- ⑤ Shield ground switch (LG)

* If there are errors in the station number and the mode switch, change the setting with the power OFF, and then turn ON the power.

* For details of switch settings, see Chapter 10.

- Check cables and connectors

[Check items of cables and connectors]

- ① No looseness or removal of connectors (turn the connector right until it completely locks).
- ② Connectors are appropriately fixed on the cables (When any faults such as extrusion of pins or connector being easily removed by pulling, reinstall these connectors.)
- ③ Wiring conditions are appropriate (See chapters 5 and 6).
- ④ Not too long branch lines (shorter than 400 mm).
- ⑤ Termination resistance are correctly connected. (Turn "ON" the termination resistance switch of the termination stations or install a terminator.)

(2) When the communication error occurs instantaneously.

Cause may be:

- Noise on the communication line.
- Fault of a communication module.
- Fault of a communication cable.

① Check the error's timing.

When the error occurs synchronous with a peripheral industrial robot's operation, noise to the communication line may be a cause. Consider arrangement of the wiring route.

② Identify the error station.

When the error occurs at only the specific station, the cause may be the station or nearby. Check the following items.

- Setting of the LT (termination resistance) switch.
- Cable *
- Error code (See page 11·1)

③ When identification of the cause is difficult.

Condition of the circuit may be unstable.*

(3) When the communication error occurs continuously.

① Identify the error station.

Specify the error's station using the communication flag etc., and check this station.

- Check the power of the error's station.
- Check the error code of the error's station.
- Check cables near the error's station.*

② When identification of the cause is difficult.

Condition of the whole circuit may be unstable. Check cables and connectors.*

*: See [Check items of cables and connectors] in the previous page.

(4) Recovery method at communication errors

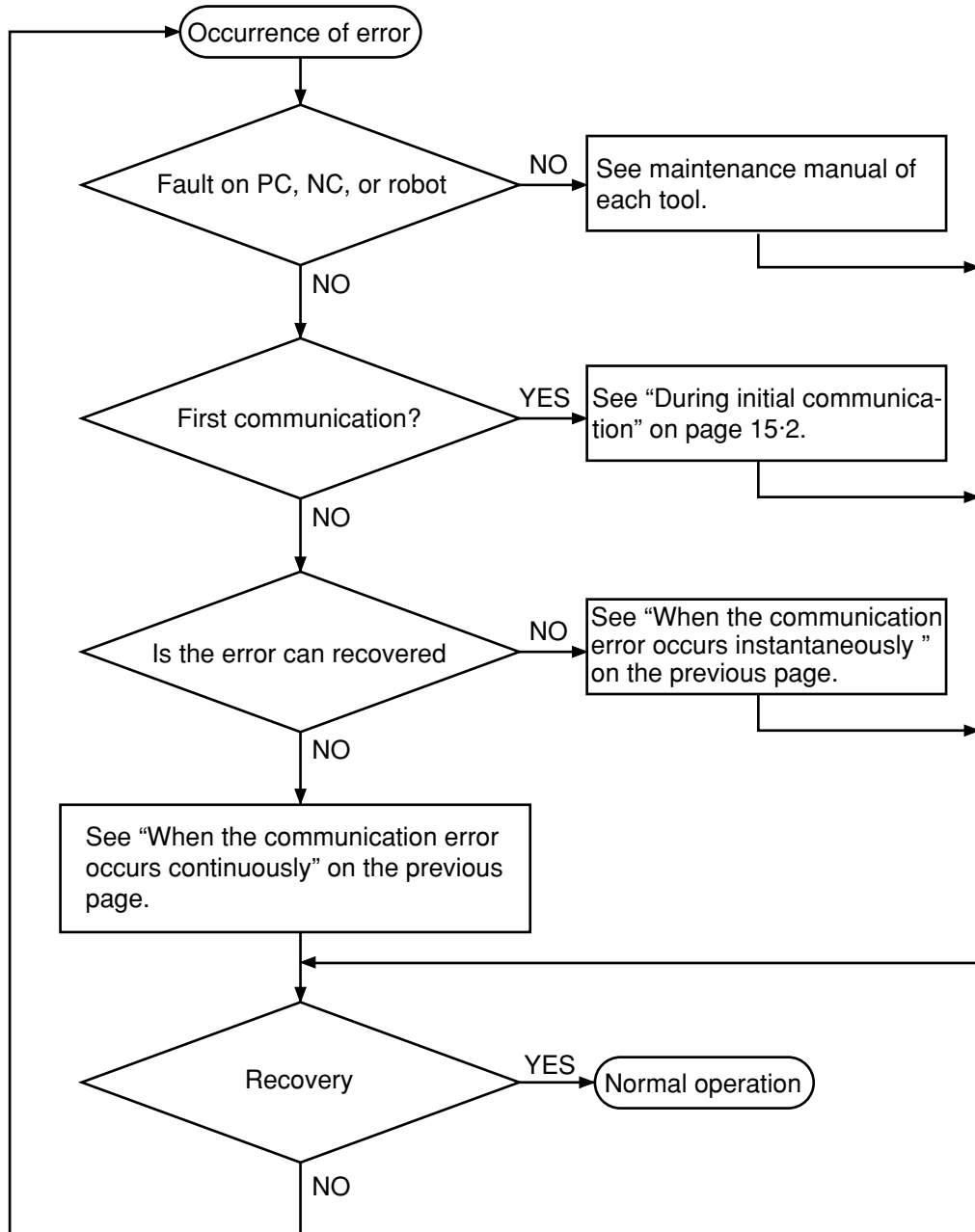

15-3 Table of parameter memory

(1) Master station

(1/5)

Address ⁽⁸⁾	Set contents	Setting method (value, example)	
000000	Store the mis-setting slave station number in the master station	—	—
004000	Top address of relay link area in the master station	(Octal, word)	When $\exists 1000$, set to $001000^{(8)}$ by file address
004001			
004002	Set function (relay/register link)	$01^{(H)}$	Fixed to $01^{(H)}$
004003	Amount of connectable stations (2 to 64 stations)	(Decimal, byte)	When 12 stations, set to $012^{(D)}$
004004 to 004007	When slave station $01^{(8)}$ is set to data link (the standard function), top address of the relay link area on slave station $01^{(8)}$ are as shown at right.	004004) When $\exists 1200$, set to $001200^{(8)}$ (Set by file address) * — $00^{(H)}$: In this case the same as the master station — $80^{(H)}$: In this case different from the master station
		004005	
		004006	
		004007	
004004 to 004007	When slave station $01^{(8)}$ is set to data link (the memory capacity save function), number of offset bytes of relay link area on slave station $01^{(8)}$ are shown at right.	004004) When 100 bytes, set to $00100^{(D)}$
		004005	
		004006	
		004007	

* When $00^{(H)}$ is set, the value becomes the same top address of the master station regardless of the setting value of 004004 to 004005⁽⁸⁾.

Address ⁽⁸⁾	Set contents
004010 to 004013	Top address or number of offset bytes on slave station $02^{(8)}$ (same as 004004 to 004007).
004014 to 004017	$03^{(8)}$ (same as 004004 to 004007)
004020 to 004023	$04^{(8)}$ (same as 004004 to 004007)
004024 to 004027	$05^{(8)}$ (same as 004004 to 004007)
004030 to 004033	$06^{(8)}$ (same as 004004 to 004007)
004034 to 004037	$07^{(8)}$ (same as 004004 to 004007)
004040 to 004043	$10^{(8)}$ (same as 004004 to 004007)
004044 to 004047	$11^{(8)}$ (same as 004004 to 004007)
004050 to 004053	$12^{(8)}$ (same as 004004 to 004007)
004054 to 004057	$13^{(8)}$ (same as 004004 to 004007)
004060 to 004063	$14^{(8)}$ (same as 004004 to 004007)
004064 to 004067	$15^{(8)}$ (same as 004004 to 004007)
004070 to 004073	$16^{(8)}$ (same as 004004 to 004007)
004074 to 004077	$17^{(8)}$ (same as 004004 to 004007)
004100 to 004103	$20^{(8)}$ (same as 004004 to 004007)
004104 to 004107	$21^{(8)}$ (same as 004004 to 004007)
004110 to 004113	$22^{(8)}$ (same as 004004 to 004007)
004114 to 004117	$23^{(8)}$ (same as 004004 to 004007)
004120 to 004123	$24^{(8)}$ (same as 004004 to 004007)
004124 to 004127	$25^{(8)}$ (same as 004004 to 004007)
004130 to 004133	$26^{(8)}$ (same as 004004 to 004007)
004134 to 004137	$27^{(8)}$ (same as 004004 to 004007)
004140 to 004143	$30^{(8)}$ (same as 004004 to 004007)
004144 to 004147	$31^{(8)}$ (same as 004004 to 004007)
004150 to 004153	$32^{(8)}$ (same as 004004 to 004007)
004154 to 004157	$33^{(8)}$ (same as 004004 to 004007)
004160 to 004163	$34^{(8)}$ (same as 004004 to 004007)
004164 to 004167	$35^{(8)}$ (same as 004004 to 004007)
004170 to 004173	$36^{(8)}$ (same as 004004 to 004007)
004174 to 004177	$37^{(8)}$ (same as 004004 to 004007)

Address ⁽⁸⁾	Set contents
004200 to 004203	Top address or number of offset bytes on slave station $40^{(8)}$ (same as 004004 to 004007).
004204 to 004207	$41^{(8)}$ (same as 004004 to 004007)
004210 to 004213	$42^{(8)}$ (same as 004004 to 004007)
004214 to 004217	$43^{(8)}$ (same as 004004 to 004007)
004220 to 004223	$44^{(8)}$ (same as 004004 to 004007)
004224 to 004227	$45^{(8)}$ (same as 004004 to 004007)
004230 to 004233	$46^{(8)}$ (same as 004004 to 004007)
004234 to 004237	$47^{(8)}$ (same as 004004 to 004007)
004240 to 004243	$50^{(8)}$ (same as 004004 to 004007)
004244 to 004247	$51^{(8)}$ (same as 004004 to 004007)
004250 to 004253	$52^{(8)}$ (same as 004004 to 004007)
004254 to 004257	$53^{(8)}$ (same as 004004 to 004007)
004260 to 004263	$54^{(8)}$ (same as 004004 to 004007)
004264 to 004267	$55^{(8)}$ (same as 004004 to 004007)
004270 to 004273	$56^{(8)}$ (same as 004004 to 004007)
004274 to 004277	$57^{(8)}$ (same as 004004 to 004007)
004300 to 004303	$60^{(8)}$ (same as 004004 to 004007)
004304 to 004307	$61^{(8)}$ (same as 004004 to 004007)
004310 to 004313	$62^{(8)}$ (same as 004004 to 004007)
004314 to 004317	$63^{(8)}$ (same as 004004 to 004007)
004320 to 004323	$64^{(8)}$ (same as 004004 to 004007)
004324 to 004327	$65^{(8)}$ (same as 004004 to 004007)
004330 to 004333	$66^{(8)}$ (same as 004004 to 004007)
004334 to 004337	$67^{(8)}$ (same as 004004 to 004007)
004340 to 004343	$70^{(8)}$ (same as 004004 to 004007)
004344 to 004347	$71^{(8)}$ (same as 004004 to 004007)
004350 to 004353	$72^{(8)}$ (same as 004004 to 004007)
004354 to 004357	$73^{(8)}$ (same as 004004 to 004007)
004360 to 004363	$74^{(8)}$ (same as 004004 to 004007)
004364 to 004367	$75^{(8)}$ (same as 004004 to 004007)
004370 to 004373	$76^{(8)}$ (same as 004004 to 004007)
004374 to 004377	$77^{(8)}$ (same as 004004 to 004007)

· Initial value of the address 004000 to 004377⁽⁸⁾ are all $00^{(H)}$.

Address (8)	Set contents	Setting method (value, example)	
004400	Top address of register link area in the master station	(Octal, word)	
004401) When 09000 ₍₈₎ , set to 004000 ₍₈₎ by file address When file No.1 = 01 _(H)	
004402			(Hexadecimal, byte)
004403			00 _(H)
004404 to 004407	When slave station 01 ₍₈₎ is set to data link (the standard function), top address of the register link area on slave station 01 ₍₈₎ are as shown at right.	004404 (Octal, word)	
		004405 (Octal, word)	
		004406 (Hexadecimal, byte)	
		004407 (Hexadecimal, byte)	
004404 to 004407	When slave station 01 ₍₈₎ is set to data link (the memory capacity save function), number of offset bytes of register link area on slave station 01 ₍₈₎ are shown at right.	004404 (Octal, word)	
		004405 (Octal, word)	
		004406 (Hexadecimal, byte)	
		004407 (Hexadecimal, byte)	
004404 to 004407	When slave station 01 ₍₈₎ is set to data link (the memory capacity save function), number of offset bytes of register link area on slave station 01 ₍₈₎ are shown at right.	004404 (Octal, word)	
		004405 (Octal, word)	
		004406 (Hexadecimal, byte)	
		004407 (Hexadecimal, byte)	
004404 to 004407	When slave station 01 ₍₈₎ is set to data link (the memory capacity save function), number of offset bytes of register link area on slave station 01 ₍₈₎ are shown at right.	004404 (Octal, word)	
		004405 (Octal, word)	
		004406 (Hexadecimal, byte)	
		004407 (Hexadecimal, byte)	

* When 00_(H) is set, the value becomes the same top address of the master station regardless of the setting value of 004404 to 004405₍₈₎.

Address (8)	Set contents
004410 to 004413	Top address or number of offset bytes on slave station 02 ₍₈₎ (same as 004404 to 004407).
004414 to 004417	03 ₍₈₎ (same as 004404 to 004407)
004420 to 004423	04 ₍₈₎ (same as 004404 to 004407)
004424 to 004427	05 ₍₈₎ (same as 004404 to 004407)
004430 to 004433	06 ₍₈₎ (same as 004404 to 004407)
004434 to 004437	07 ₍₈₎ (same as 004404 to 004407)
004440 to 004443	10 ₍₈₎ (same as 004404 to 004407)
004444 to 004447	11 ₍₈₎ (same as 004404 to 004407)
004450 to 004453	12 ₍₈₎ (same as 004404 to 004407)
004454 to 004457	13 ₍₈₎ (same as 004404 to 004407)
004460 to 004463	14 ₍₈₎ (same as 004404 to 004407)
004464 to 004467	15 ₍₈₎ (same as 004404 to 004407)
004470 to 004473	16 ₍₈₎ (same as 004404 to 004407)
004474 to 004477	17 ₍₈₎ (same as 004404 to 004407)
004500 to 004503	20 ₍₈₎ (same as 004404 to 004407)
004504 to 004507	21 ₍₈₎ (same as 004404 to 004407)
004510 to 004513	22 ₍₈₎ (same as 004404 to 004407)
004514 to 004517	23 ₍₈₎ (same as 004404 to 004407)
004520 to 004523	24 ₍₈₎ (same as 004404 to 004407)
004524 to 004527	25 ₍₈₎ (same as 004404 to 004407)
004530 to 004533	26 ₍₈₎ (same as 004404 to 004407)
004534 to 004537	27 ₍₈₎ (same as 004404 to 004407)
004540 to 004543	30 ₍₈₎ (same as 004404 to 004407)
004544 to 004547	31 ₍₈₎ (same as 004404 to 004407)
004550 to 004553	32 ₍₈₎ (same as 004404 to 004407)
004554 to 004557	33 ₍₈₎ (same as 004404 to 004407)
004560 to 004563	34 ₍₈₎ (same as 004404 to 004407)
004564 to 004567	35 ₍₈₎ (same as 004404 to 004407)
004570 to 004573	36 ₍₈₎ (same as 004404 to 004407)
004574 to 004577	37 ₍₈₎ (same as 004404 to 004407)

Address (8)	Set contents
004600 to 004603	Top address or number of offset bytes on slave station 40 ₍₈₎ (same as 004404 to 004407).
004604 to 004607	41 ₍₈₎ (same as 004404 to 004407)
004610 to 004613	42 ₍₈₎ (same as 004404 to 004407)
004614 to 004617	43 ₍₈₎ (same as 004404 to 004407)
004620 to 004623	44 ₍₈₎ (same as 004404 to 004407)
004624 to 004627	45 ₍₈₎ (same as 004404 to 004407)
004630 to 004633	46 ₍₈₎ (same as 004404 to 004407)
004634 to 004637	47 ₍₈₎ (same as 004404 to 004407)
004640 to 004643	50 ₍₈₎ (same as 004404 to 004407)
004644 to 004647	51 ₍₈₎ (same as 004404 to 004407)
004650 to 004653	52 ₍₈₎ (same as 004404 to 004407)
004654 to 004657	53 ₍₈₎ (same as 004404 to 004407)
004660 to 004663	54 ₍₈₎ (same as 004404 to 004407)
004664 to 004667	55 ₍₈₎ (same as 004404 to 004407)
004670 to 004673	56 ₍₈₎ (same as 004404 to 004407)
004674 to 004677	57 ₍₈₎ (same as 004404 to 004407)
004700 to 004703	60 ₍₈₎ (same as 004404 to 004407)
004704 to 004707	61 ₍₈₎ (same as 004404 to 004407)
004710 to 004713	62 ₍₈₎ (same as 004404 to 004407)
004714 to 004717	63 ₍₈₎ (same as 004404 to 004407)
004720 to 004723	64 ₍₈₎ (same as 004404 to 004407)
004724 to 004727	65 ₍₈₎ (same as 004404 to 004407)
004730 to 004733	66 ₍₈₎ (same as 004404 to 004407)
004734 to 004737	67 ₍₈₎ (same as 004404 to 004407)
004740 to 004743	70 ₍₈₎ (same as 004404 to 004407)
004744 to 004747	71 ₍₈₎ (same as 004404 to 004407)
004750 to 004753	72 ₍₈₎ (same as 004404 to 004407)
004754 to 004757	73 ₍₈₎ (same as 004404 to 004407)
004760 to 004763	74 ₍₈₎ (same as 004404 to 004407)
004764 to 004767	75 ₍₈₎ (same as 004404 to 004407)
004770 to 004773	76 ₍₈₎ (same as 004404 to 004407)
004774 to 004777	77 ₍₈₎ (same as 004404 to 004407)

· Initial value of the address 004400 to 004777₍₈₎ are all 00_(H).

Address (8)	Set contents	Setting method (value, example)	
005000	Number of sending bytes of master station relay link area	(Decimal, word)	When 8 bytes, set to 00008 _(D)
005001			
005002	Number of sending bytes of slave station 01 ₍₈₎ relay link area	(Decimal, word)	
005003			

Address (8)	Set contents
005004 to 005005	Number of sending bytes of slave station 02 ₍₈₎ relay link area (same as 005002 to 005003).
005006 to 005007	03 ₍₈₎ (same as 005002 to 005003)
005010 to 005011	04 ₍₈₎ (same as 005002 to 005003)
005012 to 005013	05 ₍₈₎ (same as 005002 to 005003)
005014 to 005015	06 ₍₈₎ (same as 005002 to 005003)
005016 to 005017	07 ₍₈₎ (same as 005002 to 005003)
005020 to 005021	10 ₍₈₎ (same as 005002 to 005003)
005022 to 005023	11 ₍₈₎ (same as 005002 to 005003)
005024 to 005025	12 ₍₈₎ (same as 005002 to 005003)
005026 to 005027	13 ₍₈₎ (same as 005002 to 005003)
005030 to 005031	14 ₍₈₎ (same as 005002 to 005003)
005032 to 005033	15 ₍₈₎ (same as 005002 to 005003)
005034 to 005035	16 ₍₈₎ (same as 005002 to 005003)
005036 to 005037	17 ₍₈₎ (same as 005002 to 005003)
005040 to 005041	20 ₍₈₎ (same as 005002 to 005003)
005042 to 005043	21 ₍₈₎ (same as 005002 to 005003)
005044 to 005045	22 ₍₈₎ (same as 005002 to 005003)
005046 to 005047	23 ₍₈₎ (same as 005002 to 005003)
005050 to 005051	24 ₍₈₎ (same as 005002 to 005003)
005052 to 005053	25 ₍₈₎ (same as 005002 to 005003)
005054 to 005055	26 ₍₈₎ (same as 005002 to 005003)
005056 to 005057	27 ₍₈₎ (same as 005002 to 005003)
005060 to 005061	30 ₍₈₎ (same as 005002 to 005003)
005062 to 005063	31 ₍₈₎ (same as 005002 to 005003)
005064 to 005065	32 ₍₈₎ (same as 005002 to 005003)
005066 to 005067	33 ₍₈₎ (same as 005002 to 005003)
005070 to 005071	34 ₍₈₎ (same as 005002 to 005003)
005072 to 005073	35 ₍₈₎ (same as 005002 to 005003)
005074 to 005075	36 ₍₈₎ (same as 005002 to 005003)
005076 to 005077	37 ₍₈₎ (same as 005002 to 005003)

Address (8)	Set contents
005100 to 005101	Number of sending bytes of slave station 40 ₍₈₎ relay link area (same as 005002 to 005003).
005102 to 005103	41 ₍₈₎ (same as 005002 to 005003)
005104 to 005105	42 ₍₈₎ (same as 005002 to 005003)
005106 to 005107	43 ₍₈₎ (same as 005002 to 005003)
005110 to 005111	44 ₍₈₎ (same as 005002 to 005003)
005112 to 005113	45 ₍₈₎ (same as 005002 to 005003)
005114 to 005115	46 ₍₈₎ (same as 005002 to 005003)
005116 to 005117	47 ₍₈₎ (same as 005002 to 005003)
005120 to 005121	50 ₍₈₎ (same as 005002 to 005003)
005122 to 005123	51 ₍₈₎ (same as 005002 to 005003)
005124 to 005125	52 ₍₈₎ (same as 005002 to 005003)
005126 to 005127	53 ₍₈₎ (same as 005002 to 005003)
005130 to 005131	54 ₍₈₎ (same as 005002 to 005003)
005132 to 005133	55 ₍₈₎ (same as 005002 to 005003)
005134 to 005135	56 ₍₈₎ (same as 005002 to 005003)
005136 to 005137	57 ₍₈₎ (same as 005002 to 005003)
005140 to 005141	60 ₍₈₎ (same as 005002 to 005003)
005142 to 005143	61 ₍₈₎ (same as 005002 to 005003)
005144 to 005145	62 ₍₈₎ (same as 005002 to 005003)
005146 to 005147	63 ₍₈₎ (same as 005002 to 005003)
005150 to 005151	64 ₍₈₎ (same as 005002 to 005003)
005152 to 005153	65 ₍₈₎ (same as 005002 to 005003)
005154 to 005155	66 ₍₈₎ (same as 005002 to 005003)
005156 to 005157	67 ₍₈₎ (same as 005002 to 005003)
005160 to 005161	70 ₍₈₎ (same as 005002 to 005003)
005162 to 005163	71 ₍₈₎ (same as 005002 to 005003)
005164 to 005165	72 ₍₈₎ (same as 005002 to 005003)
005166 to 005167	73 ₍₈₎ (same as 005002 to 005003)
005170 to 005171	74 ₍₈₎ (same as 005002 to 005003)
005172 to 005173	75 ₍₈₎ (same as 005002 to 005003)
005174 to 005175	76 ₍₈₎ (same as 005002 to 005003)
005176 to 005177	77 ₍₈₎ (same as 005002 to 005003)

· Initial value of the address 005000 to 005177₍₈₎ are all 00_(H).

Address (8)	Set contents	Setting method (value, example)	
005200	Number of sending bytes of master station register link area	(Decimal, word)	When 64 bytes, set to 00064 _(D)
005201			
005202	Number of sending bytes of slave station 01 ₍₈₎ register link area	(Decimal, word)	
005203			

Address (8)	Set contents
005204 to 005205	Number of sending bytes of slave station 02 ₍₈₎ register link area (same as 005202 to 005203).
005206 to 005207	03 ₍₈₎ (same as 005202 to 005203)
005210 to 005211	04 ₍₈₎ (same as 005202 to 005203)
005212 to 005213	05 ₍₈₎ (same as 005202 to 005203)
005214 to 005215	06 ₍₈₎ (same as 005202 to 005203)
005216 to 005217	07 ₍₈₎ (same as 005202 to 005203)
005220 to 005221	10 ₍₈₎ (same as 005202 to 005203)
005222 to 005223	11 ₍₈₎ (same as 005202 to 005203)
005224 to 005225	12 ₍₈₎ (same as 005202 to 005203)
005226 to 005227	13 ₍₈₎ (same as 005202 to 005203)
005230 to 005231	14 ₍₈₎ (same as 005202 to 005203)
005232 to 005233	15 ₍₈₎ (same as 005202 to 005203)
005234 to 005235	16 ₍₈₎ (same as 005202 to 005203)
005236 to 005237	17 ₍₈₎ (same as 005202 to 005203)
005240 to 005241	20 ₍₈₎ (same as 005202 to 005203)
005242 to 005243	21 ₍₈₎ (same as 005202 to 005203)
005244 to 005245	22 ₍₈₎ (same as 005202 to 005203)
005246 to 005247	23 ₍₈₎ (same as 005202 to 005203)
005250 to 005251	24 ₍₈₎ (same as 005202 to 005203)
005252 to 005253	25 ₍₈₎ (same as 005202 to 005203)
005254 to 005255	26 ₍₈₎ (same as 005202 to 005203)
005256 to 005257	27 ₍₈₎ (same as 005202 to 005203)
005260 to 005261	30 ₍₈₎ (same as 005202 to 005203)
005262 to 005263	31 ₍₈₎ (same as 005202 to 005203)
005264 to 005265	32 ₍₈₎ (same as 005202 to 005203)
005266 to 005267	33 ₍₈₎ (same as 005202 to 005203)
005270 to 005271	34 ₍₈₎ (same as 005202 to 005203)
005272 to 005273	35 ₍₈₎ (same as 005202 to 005203)
005274 to 005275	36 ₍₈₎ (same as 005202 to 005203)
005276 to 005277	37 ₍₈₎ (same as 005202 to 005203)

Address (8)	Set contents
005300 to 005301	Number of sending bytes of slave station 40 ₍₈₎ register link area (same as 005202 to 005203).
005302 to 005303	41 ₍₈₎ (same as 005202 to 005203)
005304 to 005305	42 ₍₈₎ (same as 005202 to 005203)
005306 to 005307	43 ₍₈₎ (same as 005202 to 005203)
005310 to 005311	44 ₍₈₎ (same as 005202 to 005203)
005312 to 005313	45 ₍₈₎ (same as 005202 to 005203)
005314 to 005315	46 ₍₈₎ (same as 005202 to 005203)
005316 to 005317	47 ₍₈₎ (same as 005202 to 005203)
005320 to 005321	50 ₍₈₎ (same as 005202 to 005203)
005322 to 005323	51 ₍₈₎ (same as 005202 to 005203)
005324 to 005325	52 ₍₈₎ (same as 005202 to 005203)
005326 to 005327	53 ₍₈₎ (same as 005202 to 005203)
005330 to 005331	54 ₍₈₎ (same as 005202 to 005203)
005332 to 005333	55 ₍₈₎ (same as 005202 to 005203)
005334 to 005335	56 ₍₈₎ (same as 005202 to 005203)
005336 to 005337	57 ₍₈₎ (same as 005202 to 005203)
005340 to 005341	60 ₍₈₎ (same as 005202 to 005203)
005342 to 005343	61 ₍₈₎ (same as 005202 to 005203)
005344 to 005345	62 ₍₈₎ (same as 005202 to 005203)
005346 to 005347	63 ₍₈₎ (same as 005202 to 005203)
005350 to 005351	64 ₍₈₎ (same as 005202 to 005203)
005352 to 005353	65 ₍₈₎ (same as 005202 to 005203)
005354 to 005355	66 ₍₈₎ (same as 005202 to 005203)
005356 to 005357	67 ₍₈₎ (same as 005202 to 005203)
005360 to 005361	70 ₍₈₎ (same as 005202 to 005203)
005362 to 005363	71 ₍₈₎ (same as 005202 to 005203)
005364 to 005365	72 ₍₈₎ (same as 005202 to 005203)
005366 to 005367	73 ₍₈₎ (same as 005202 to 005203)
005370 to 005371	74 ₍₈₎ (same as 005202 to 005203)
005372 to 005373	75 ₍₈₎ (same as 005202 to 005203)
005374 to 005375	76 ₍₈₎ (same as 005202 to 005203)
005376 to 005377	77 ₍₈₎ (same as 005202 to 005203)

· Initial value of the address 005200 to 005377₍₈₎ are all 00_(H).

Address (8)	Set contents	Setting method (value, example)									
007750 to 007757	Connection condition of slave station • Turn ON the corresponding bit of connected station number (01 to 77 ⁽⁸⁾) from the list at right. • 00 ⁽⁸⁾ of master station (0 bit of address 007750) At ON: Output error code At OFF: Do not output error code.	Bit address	7	6	5	4	3	2	1	0	• When connecting slave station 01 to 04 ⁽⁸⁾ and output error code: (Address) (Bit pattern) 007750 — 00011111 007751 — 00000000 to to 007757 — 00000000
		007750	07	06	05	04	03	02	01	00	
		007751	17	16	15	14	13	12	11	10	
		007752	27	26	25	24	23	22	21	20	
		007753	37	36	35	34	33	32	31	30	
		007754	47	46	45	44	43	42	41	40	
007755	57	56	55	54	53	52	51	50			
007756	67	66	65	64	63	62	61	60			
007757	77	76	75	74	73	72	71	70			
007763	Whether the station number information should be output or not <input type="checkbox"/> V5	00 ^(H)								Do not output	
		01 ^(H)								Output	
007764 to 007767	Flag area top address on the master station	007764	(Octal, word)) When 10200, set to 000200 ⁽⁸⁾ (Set by file address)
		007765									
		007766	(Hexadecimal, byte)) When file number is 2, set to 02 ^(H) <input type="checkbox"/> 00 ^(H) : Do not output flag <input type="checkbox"/> 80 ^(H) : Output flag							
		007767	●								
007777	Stop operation of the data link	00 ^(H)								_____	
	Start operation of the data link	01 ^(H)									
	Writing to EEPROM or operation of the JW-20MN/stop operation	80 ^(H)									
	Writing to EEPROM or operation of the JW-20MN/start operation	81 ^(H)									
	Initialize parameter settings	08 ^(H)									

· For initial values of above address, see page 10-13.

(2) Slave station (01 to 77₍₈₎)

Address ₍₈₎	Set contents	Setting method (value, example)		
007720 007721	Number of receiving bytes of relay link in memory capacity save function V5	(Decimal, word)	When 8 bytes, set to 00008 _(D)	
007722 007723	Number of receiving bytes of register link in memory capacity save function V5	(Decimal, word)	When 64 bytes, set to 00064 _(D)	
007730 to 007733	Top address of relay link area in memory capacity save function V5	007730	} When 10200, set to 001200 ₍₈₎ (Set by file address)	
		007731		(Octal, byte)
		007732		00 _(H)
		007733		00 _(H)
007734 to 007737	Top address of register link area in memory capacity save function V5	007734	} When 09000, set to 004000 ₍₈₎ (Set by file address)	
		007735		(Octal, byte)
		007736	(Hexadecimal, byte)	} When file number is 0, set to 00 _(H)
		007737	00 _(H)	
007763	Whether the station number information should be output or not V5	00 _(H)	Do not output	
		00 _(H)	Output	
007764 to 007767	Top address of flag area on each slave station	007764	} When 10600, set to 000600 ₍₈₎ (Set by file address)	
		007765		(Octal, word)
		007766	(Hexadecimal, byte)	} When file number is 2, set to 02 _(H)
		007767	●	
007777	Stop operation of the data link	00 _(H)	_____	
	Start operation of the data link	01 _(H)		
	Writing to EEPROM or operation of the JW-20MN / stop operation	80 _(H)		
	Writing to EEPROM or operation of the JW-20MN / start operation	81 _(H)		
	Initialize parameter settings	08 _(H)		

· For initial values of above address, see page 10· 6.

15-4 Address map of data memory

(1) Date link

(File 0)

	I/O address of Sharp PC			ME-NET address		Setting range	
	Bit address ⁽⁸⁾ 1 address = 1 point	Byte address ⁽⁸⁾ 1 address = 8 points	File address ⁽⁸⁾ 1 address = 8 points	Hexadecimal in units of byte	Octal in units of byte	W70H W100H	JW50/70/100 JW50H/70H/100H
I/O relay	00000 to 03777	00000 to 00377	000000 to 000377	0000 to 00FF	000000 to 000377	Relay link area Register link area Flag area	Relay link area Register link area Flag area
Auxiliary relay	04000 to 06777	00400 to 00677	000400 to 000677	0100 to 016F	000400 to 000677		
Latched relay	07000 to 07777	00700 to 00777	000700 to 000777	0170 to 01FF	000700 to 000777		
General purpose relay	10000 to 15777	01000 to 01577	001000 to 001577	0200 to 037F	001000 to 001577		
TMR/CNT contact	T-C000 to T-C777		001600 to 001777	0380 to 03FF	001600 to 001777		
TMR/CNT /MD current value		b0000 to b1777	002000 to 003777	0400 to 07FF	002000 to 003777		
Register		09000 to 09777	004000 to 004777	0800 to 09FF	004000 to 004777		
Register		19000 to 19777	005000 to 005777	0A00 to 0BFF	005000 to 005777		
Register		29000 to 29777	006000 to 006777	0C00 to 0DFF	006000 to 006777		
Register		39000 to 39777	007000 to 007777	0E00 to 0FFF	007000 to 007777		
Register		49000 to 49777	010000 to 010777	1000 to 11FF	010000 to 010777		
Register		59000 to 59777	011000 to 011777	1200 to 13FF	011000 to 011777		
Register		69000 to 69777	012000 to 012777	1400 to 15FF	012000 to 012777		
Register		79000 to 79777	013000 to 013777	1600 to 17FF	013000 to 013777		
Register		89000 to 89777	014000 to 014777	1800 to 19FF	014000 to 014777		
Register		99000 to 99777	015000 to 015777	1A00 to 1BFF	015000 to 015777		
Register		E0000 to E1777	016000 to 016777	1C00 to 1FFF	016000 to 017777		

	I/O address of Sharp PC			ME-NET address		Setting range	
	Bit address ⁽⁸⁾ 1 address = 1 point	Byte address ⁽⁸⁾ 1 address = 8 points	File address ⁽⁸⁾ 1 address = 8 points	Hexadecimal in units of byte	Octal in units of byte	W70H W100H	JW50/70/100 JW50H/70H/100H
File 1 Register			000000 to 177777	0000 to FFFF	000000 to 177777	Register link area Flag area	Register link area Flag area
File 2 Register			000000 to 177777	0000 to FFFF	000000 to 177777		
File 3 Register			000000 to 177777	0000 to FFFF	000000 to 177777		
File 4 Register			000000 to 177777	0000 to FFFF	000000 to 177777		
File 5 Register			000000 to 177777	0000 to FFFF	000000 to 177777		
File 6 Register			000000 to 177777	0000 to FFFF	000000 to 177777		
File 7 Register			000000 to 177777	0000 to FFFF	000000 to 177777		

- Set addresses of the relay link area, register link area, and flag area so that they will not doubled.
- When the data memory is used as relay link area, register link area, or flag area, make sure that its address is not used for other purpose. Especially the following addresses are already reserved for specific applications. These cannot use for other applications.
 - Special relay area (073000 to 07377⁽⁸⁾, 15760 to 15767⁽⁸⁾)
 - TMR, CNT contact (T·C000 to T·C777)
 - TMR, CNT, MD current value (b0000 to b1777) etc.
- In case of JW50/70/100 and JW50H/70H/100H, usable file numbers vary with a memory module used.

Name of memory module	Usable file numbers
ZW-1MA, JW-1MAH	0 or 1 *
ZW-2MA, JW-2MAH	0 or 1
ZW-3MA, JW-3MAH	0, 1, 2
ZW-4MA, JW-4MAH	0, 1, 2, 3, 4, 5, 6, 7

* If file number is 1, file address shall be within 000000⁽⁸⁾ to 037777⁽⁸⁾.









(2) Computer link

	PC memory address ⁽⁸⁾	ME-NET address ⁽⁸⁾	Capacity	Remarks
I/O relay	0000 to 03777	0000 to 03777	2048 points	Bit address
Auxiliary relay	04000 to 06777	04000 to 06777	1536 points	
Latched relay	07000 to 07777	07000 to 07777	512 points	
General purpose relay	10000 to 15777	10000 to 15777	3072 points	
TMR/CNT contact	T0000 to T0777	16000 to 17777	512 points	
) Odd number address only		
I/O relay	∩0000 to ∩0377	SEG0 0000 to 00377	256 bytes	Byte address
Auxiliary relay	∩0400 to ∩0677	SEG0 00400 to 00677	192 bytes	
Latched relay	∩0700 to ∩0777	SEG0 00700 to 00777	64 bytes	
General purpose relay	∩1000 to ∩1577	SEG0 01000 to 01577	384 bytes	
TMR/CNT current value	b0000 to b1777	SEG0 02000 to 03777	1024 bytes	
Register	09000 to 09777	SEG0 04000 to 04777	512 bytes	
	19000 to 19777	SEG0 05000 to 05777	512 bytes	
	29000 to 29777	SEG0 06000 to 06777	512 bytes	
	39000 to 39777	SEG0 07000 to 07777	512 bytes	
	49000 to 49777	SEG0 10000 to 10777	512 bytes	

	PC memory address ⁽⁸⁾	ME-NET address ⁽⁸⁾	Capacity	Remarks
Register	59000 to 59777	SEG0 11000 to 11777	512 bytes	Byte address
	69000 to 69777	SEG0 12000 to 12777	512 bytes	
	79000 to 79000	SEG0 13000 to 13777	512 bytes	
	89000 to 89777	SEG0 14000 to 14777	512 bytes	
	99000 to 99777	SEG0 15000 to 15777	512 bytes	
	E0000 to E1777	SEG0 16000 to 17777	1024 bytes	
	File 000000 1 to 7 to 177777	SEG 000000 1 to 7 to 177777	60 K bytes each	
TMR/CNT number	0000 to 0777	0000 to 0777	512	
Program address	000000 to 076777	SEG8 000000 to 076777	32256 steps	
	100000 to 176777	SEG9 000000 to 076777	32256 steps	

- Addresses 07300⁽⁸⁾ to 07377⁽⁸⁾ and addresses 15760⁽⁸⁾ to 15767⁽⁸⁾ (bit address) are special relay areas.
- The addresses that can be used vary with the PC model and capacity. For details, see the instruction manual for each model.

15-5 Switch setting table

Settings when delivered	Data link (standard function), computer link		Data link (save memory capacity function), computer link	
	Master station	Slave station	Slave station	
MODE  0	2	2	3	
STA.NO.  0	0	0 to 7	01 to 77 ⁽⁸⁾	01 to 77 ⁽⁸⁾
×10  0	0	0 to 7		
×1  0	0	0 to 7	0 to 7	0 to 7
LT (ON)  OFF	Turn ON this switch on both of the end stations in the communication circuit. Turn this switch OFF for all other stations.			
LG (ON)  ON	Select ON or OFF to ground the shield line.			
L1 (ON)  OFF	When communication line 1 is used, turn this switch ON for all of the stations. Turn OFF the L2 switch for all of the stations.			
L2 (ON)  ON	When communication line 2 is used, turn this switch ON for all of the stations. Turn OFF the L1 switch for all of the stations.			

15-6 Table for connecting cables and the connector parts

Name		Model	Manufacturer
Cable	High frequency coaxial cable	ME-5C-2V	Mitsubishi Cable Industries,. Ltd. Fujikura Cable,. Ltd. Furukawa Denko Corporation Chugoku Cable,. Ltd. Shinagawa Cable,. Ltd.
	Crimping tool	ME-42H Dice: 67-42H	Toko Denshi Corporation
Stripper for high frequency coaxial cable		CST-TM (The system consists of the main body, a blade cassette, and a blade setting gauge)	Nihon Weidmüller Co., Ltd.
Jacket	L jacket	SB-2878	Shinagawa Shoko Co., Ltd.
	T jacket	SB-2879	
Insulation tape	Self-adhesive tape	No.11	Nitto Denko Corporation
Connectors	Connector	ME-GP-01	Toko Denshi Corporation DDK Ltd.
	Straight	ME-JJ-01	
	Elbow	ME-LA-01	
	T's	ME-TA-01	
	Termination	ME-75	

15-7 Special functions unique to the JW-20MN

The functions below are not covered by the ME-NET specifications. They can only be used with PCs which are equipped with a JW-20MN, ZW-20CM2, or JW-21MN.

(1) Remote programming and remote monitor

This paragraph describes the operation procedure of any other station's PC which is connected on the ME-NET. The following support tools are available:

- Hand-held programmer JW-13PG/12PG
- Multipurpose programmer JW-50PG
- Ladder software JW-50SP

Note 1

- If the JW-20MN remotely programs or monitors the new JW30H model (JW-31CUH1/32CUH1/33CUH1/33CUH2/33CUH3), they should be used in the combination below.

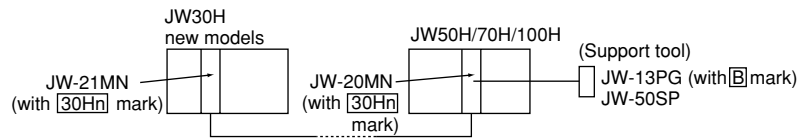

If the JW-20MN, to which a support tool is connected, has a **30H** sticker, the JW-20MN will identify the new JW30H model as conventional model (JW-31CUH/32CUH/33CUH).

If the JW-20MN, to which a support tool is connected, does not have a **30H** **30Hn** sticker, it must be used with the following limitations.

Ex.:

- If the JW-13PG has a **B** sticker, it will identify the new JW30H model as JW20H (JW-22CU).
- If a support tool JW-50SP is used, it will identify the new JW30H model properly. However, it cannot handle the secret function.

- If the JW-20MN remotely programs or monitors the conventional JW30H model (JW-31CUH/32CUH/33CUH), they should be used in the combination below.

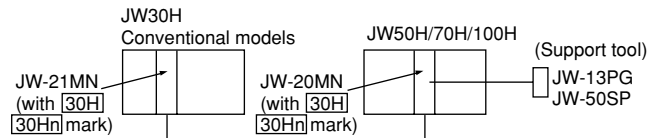

If the JW-20MN, to which a support tool is connected, does not have a **30H** **30Hn** sticker, it must be used with the following limitations.

Ex.:

- If a support tool JW-13PG is used, it will identify the conventional JW30H model as JW20H (JW-22CU).
- If a support tool JW-92SP is used, it will identify the conventional JW30H model properly. However, it cannot handle the secret function.

Note 2

- If you want to use the remote programming and monitoring functions with the JW50H/70H/100H, use the modules in the combinations shown below. If they are arranged in some other fashion, you cannot use the JW50H/70H/100H expansion function properly (with the JW50/70/100).

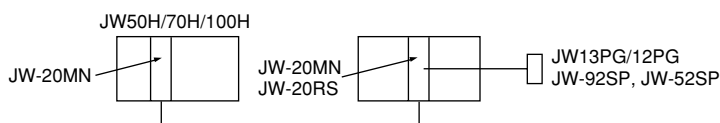

Ex.: If remote programming or remote monitoring is executed with the combination below (enter 200₍₈₎ or 201₍₈₎ at station A system memory address #0201), there are the following limitations:

- TMR/CNT1000 to 1777 will not be displayed properly.
- You will be unable to write/insert/delete programs using the TMR/CNT instructions.

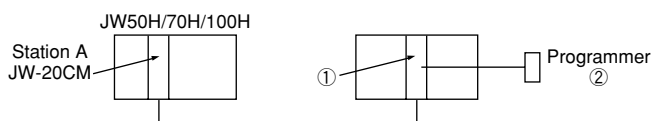

- If ① is a ZW-20CM and ② is a JW-12PG.
- If ① is a ZW/JW-20MN and ② is a JW-11PG.

① Function

< Standard network connection >

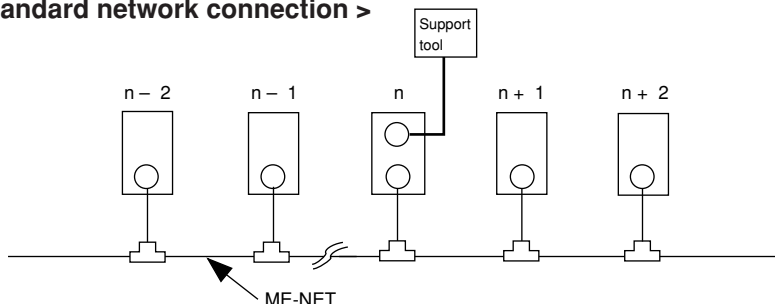

< Expansion network connection >

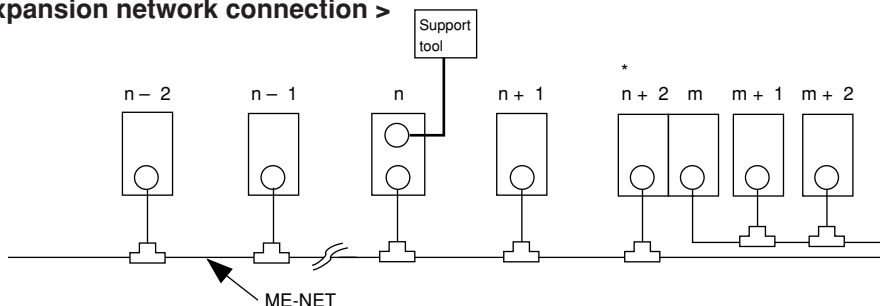

* The JW-21MN is unusable as a junction station ("n + 2" station and "m" station in the figure above). Use JW30H (JW-22CM), JW50H/70H/100H (JW-20CM).

The following operations are possible for "n" station and other stations using a support tool which is connected to the "n" station for standard/expansion network connection.

- Change program
 - Monitor
 - Change of parameter, memory (only available for JW-13PG/12PG)
- (Writing data (change program) during operation of the PC is not available for hazard prevention reasons. Stop operation of the PC prior to writing data.)

② **Operation example**

This paragraph describes an operation example using the multipurpose programmer: JW-50PG. For operations with other support tools, see the attached instruction manuals.

- Connect the JW-50PG to the JW-20CM on the ME-NET.

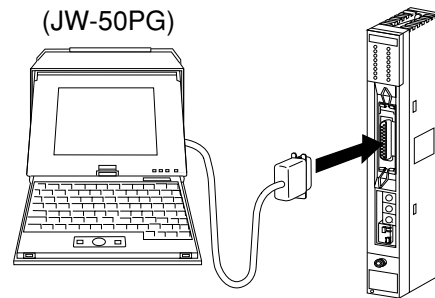

- Set communication mode
Set the communication mode of the JW-50PG to "Network CONCT." and this enables remote programming and remote monitor.

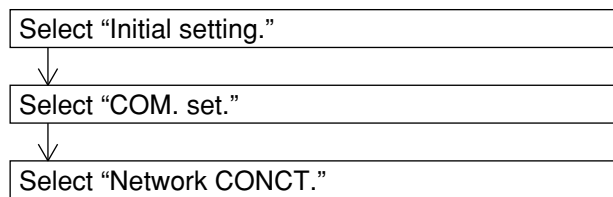

- Network setting
Select whether the target station for remote programming or remote monitor is on the standard network connection or on the extension network connection.
In the case below, 10 to 12₍₈₎ are standard network connections. 01 to 03₍₈₎ are extension network connections.

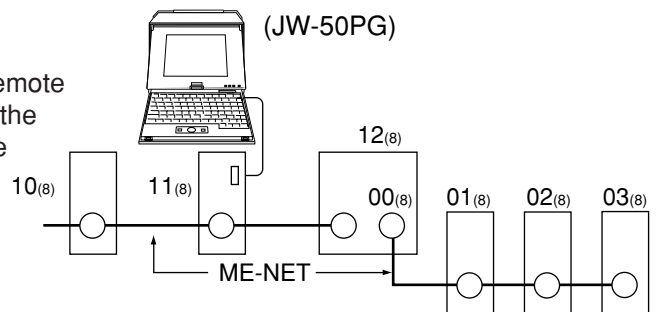

<Standard network connection>

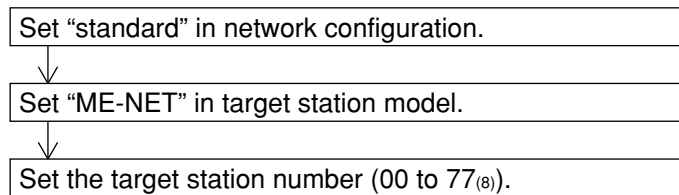

< Expansion network connection >

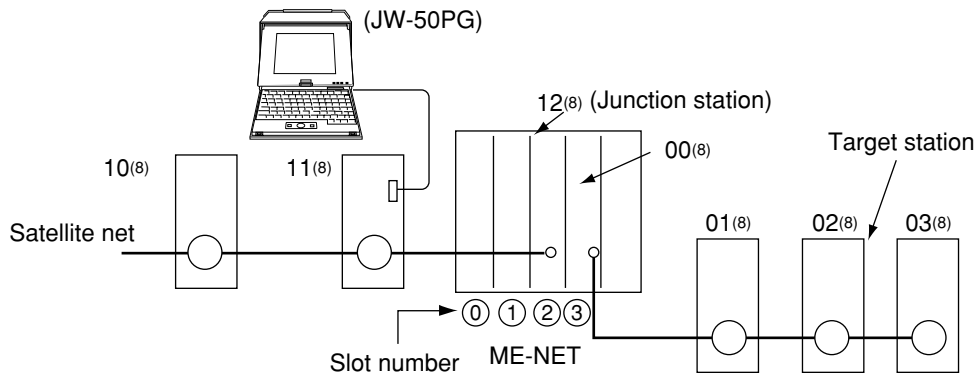

- Set "extension" in network configuration.
- ↓
- Set "ME-NET" in junction station model.
- ↓
- Set the target station number "ME-NET."
- ↓
- Set the target station number (00 to 77₍₈₎).
- ↓ (In the case of the above figure: 02₍₈₎)
- Set the junction station number (00 to 77₍₈₎).
- ↓ (In the case of the above figure: 12₍₈₎)
- Set the junction station rack number.
- ↓ (Keep the initial value "0")
- Set the station slot number.

(Set the installed slot number of the master station on the target station side. In the case of the above figure: 3.)

(2) Parameter setting by remote function

This paragraph describes how to set the parameters of other stations' network module connected on the ME-NET. This is only available when the target station is within the standard network connection.

Usable support tools are JW-13PG/12PG.

< An operation example using the JW-13PG >

- ① Connect the programmer
Connect the programmer to the JW-20MN on the ME-NET.

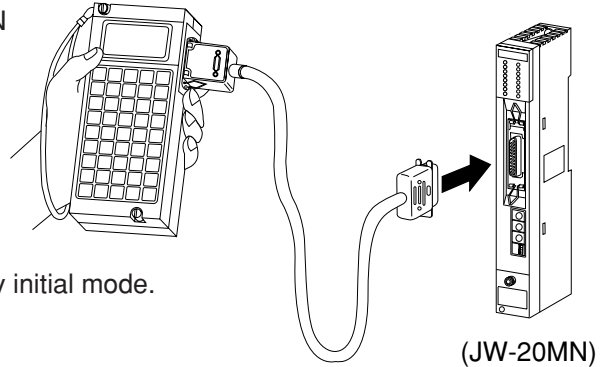

- ② Setting mode
Select initial mode.

→ Display initial mode.

- ③ Assign the link
Assign the parameter setting remotely.

→ Select "LINK" in initial.

→ Select display mode of "1PG, 2PG1 MODE" in specified link.

→ Select "TARGET STA." in 1PG, 2PG1 MODE.

- ④ Setting target station
Select the target station to set the parameter remotely.

→ Change the code from hexadecimal_(H) display to octal_(O) display and input the target station (00₍₈₎ to 77₍₈₎).

- ⑤ Communication with the target station

→ Initiate communication with the target station.





⑥ Setting parameter



After finishing communication with the target station, set the parameters remotely.

·  → Return to initial menu.

· Turn the PC of the target station to program mode (stop PC operation).

· Select “PARAM.” in the initial mode.

     → Display contents of parameter address 007777₍₈₎.

  → Write in 00_(H), stop operation of the JW-20MN.

Input address  → Display contents of address to set the parameters.

Input setting value  → Setting parameter remotely.

⑦ Start the write operation to an EEPROM

After setting the parameter in section ⑥ above, write 81_(H) in parameter address 007777₍₈₎, and then write the parameter contents into the EEPROM of the JW-20MN. Then start operation of the JW-20MN.

(3) Increasing the number of bytes that can be sent by each station in the data link

In a network where all of the stations are JW-20MN, the number of data bytes that can be sent by each station can be increased to 256 bytes for relay link and 2048 bytes for register links.