



Assembly Instructions & User's Manual

38in x 60in Straight Slat Table

FSMVPT2068



Please keep this instruction manual for future reference

Customer Service: (888) 922-2336, 7:00am to 12:00am Everyday CST

Live Chat @ Academy.com: 24/7

Made in China

Table of Contents

Warnings.....	2
Tools and Parts.....	2
Assembly Instructions.....	3
Care and Maintenance.....	4
Warranty Information.....	5

Note: Before beginning assembly of product, make sure all parts are present. Compare parts with package content list and hardware contents above. If any part is missing or damaged do not attempt to assemble the unit. Contact customer service for replacement parts.

Warnings

This product requires adult assembly. Keep screws and parts away from children.

Please read this manual before assembly or use.

Do not tighten nuts or screws until assembly is complete.

Before assembly, check the package contents carefully to ensure that all parts are included.

For missing or replacement parts, contact customer service at (888) 922-2336.



SKU#: 102634274

Style#: FSMVPT2068

Tools Required (Included)

1	Allen wrench	
---	--------------	--

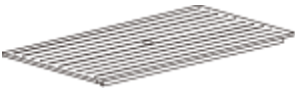
Parts List

A	Table Top		1
B	Leg		2
C	Connector		4

Hardware

D	M6 x 20mm Bolt		16
E	M6 Washer		16
F	Bolt Cap		16

Assembly Instructions

Step 1:

Turn the table top (A) upside down on a soft, non-abrasive surface to avoid scratching the table top during assembly.

Attach two table legs (B) one at a time at corner of the table using bolts 8X(D) and washers 8X(E).

Attach connector 4X(C) using bolts 8X(D) and washers 8X(E) to connect the table leg with table rim. Repeat this step at all four corners.

Tighten all bolts using included Allen wrench (G). Cover bolts with bolt cap 16X(F).

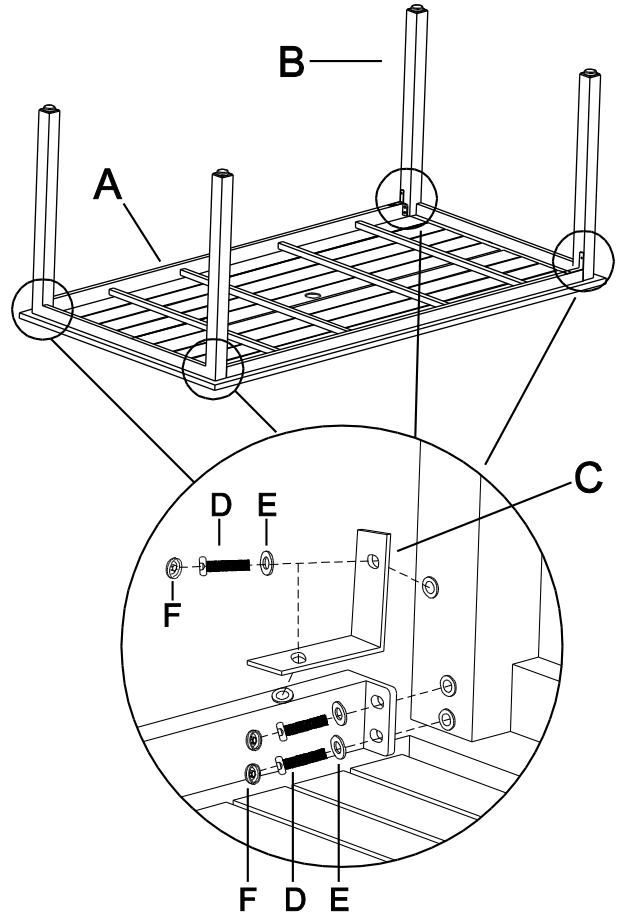

Step 2:

Turn the table top upwards and your table is now ready to use.

NOTE: There are four adjustable bolts under the table legs. Screw bolts in and out to make the table stand level on the floor.

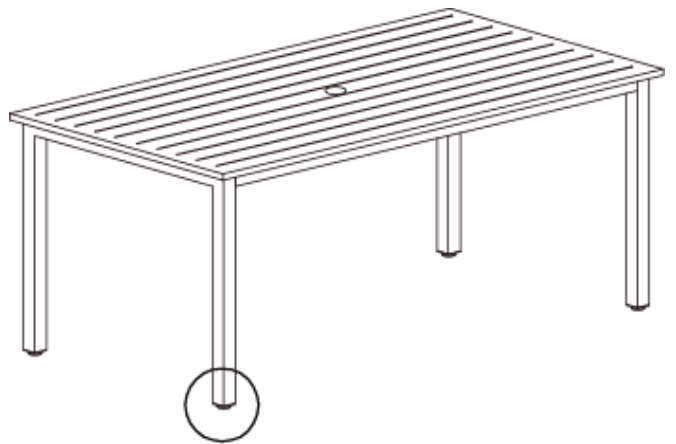

Care and Maintenance

The table should be cleaned on a regular basis to promote safe use and prolong product life.

Wipe the frame with a smooth damp cloth and air dry.

Do not use abrasive cleaners as they may damage or scratch the surface paint.

Do not leave this product in harsh weather conditions for extended periods.

For extended product life, the table should be stored indoors or covered during prolonged periods of non-use.

Storing in a dry location will help prevent rust.

Warranty Information

The appliance has been manufactured under the highest standards of quality and workmanship. We warrant to the original consumer purchaser that all aspects of this product will be free of defects in material and workmanship for one year from the date of purchase. A replacement for any defective part will be supplied free of charge for installation by the consumer. Defects or damage caused by the use of other than genuine parts are not covered by this warranty. This warranty shall be effective from the date of purchase as shown in the purchaser receipt.

This warranty is valid for the original consumer purchaser only and excludes industrial, commercial or business use of the product, product damage due to shipment or failure which results from alteration, product abuse, or product misuse, whether performed by a contractor, service company, or consumer. We will not be responsible for labor charges and/or damage incurred in installation, repair or replacement nor for incidental or consequential damage.