

BlueRS+E
BlueRS+I

A-409
Bluetooth Serial Dongle

User manual

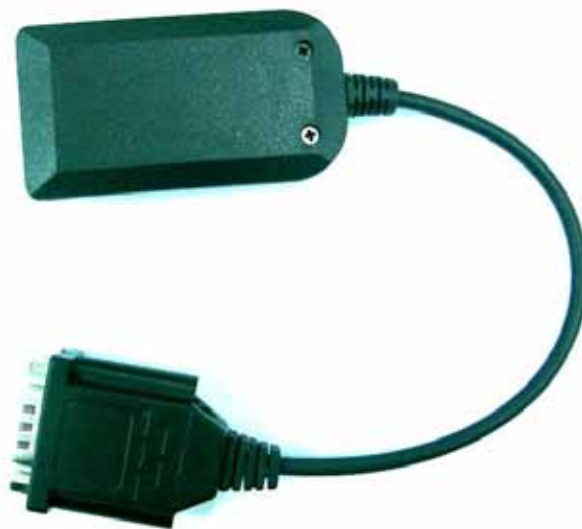

Version 1.05
Date 13/01/2005

BlueRS+E manual 1.05/01.2005

Exclusion of Liability

The present manual by Arknava reflects the present state of the art of the products described therein.

We have endeavored to give a description that is as complete and clear as possible in order to make work with our products as easy as possible for you.

All the same, the manual may contain technical inaccuracies and typing errors. As a result of the rapid advance in the art, we must also reserve the right to incorporate technical alterations and developments without separate advance notice.

That is why Arknava does not give any warranty for the contents of the manual and for its continuing applicability.

Nor is Arknava liable for any loss of information or any incorrect use of information that might result from consultation of the manual. Particularly, Arknava is not liable for damage, nor indirect damage (including damage caused by financial loss, delays affecting business transactions or interruptions of business and similar consequences), arising from the use or improper use of this manual, not even in the case where it was pointed out to Arknava or an agent of Arknava that such damage might be sustained. This does not, of course, affect our legal liability for damages based on any intent or gross negligence.

With respect to the data given in this manual, Arknava does not warrant the nonexistence of industrial property rights (trademarks, patents, utility models, etc.). Nor are trade names, brand names, company names and product names in general use but are subject to the relevant trademark, patent, utility model and registered design rights.

The information must neither in whole nor even in part be copied, translated, reproduced or in any other way transferred to or stored on any electronic medium or other machine.

The purchase and use of software are governed by the General Conditions of Delivery and Payment as well as the Terms of License of Arknava.

If any of the provisions on the exclusion of liability or on use are or become ineffective for statutory reasons, this will not affect the other provisions.

Table of contents

1 Introduction	1
1.1 Product description	1
1.2 Safety.....	1
2 Installation	2
2.1 Contents	2
2.2 Installation procedure.....	2
3 Using the BlueRS+E/I	3
3.1 Automatic connection establishment	4
3.2 AT command set for BlueRS+E/I	5
3.2.1 Bluetooth specific AT commands	12
3.2.2 AT command S register set	17
3.2.3 AT result codes	18
3.3 Table for coding Bluetooth services	19
3.4 Power down modes.....	20
3.4.1 Deep Sleep state	20
3.4.2 Power down state	20
3.4.3 Idle state	21
3.5 Power consumption.....	22
4 BlueRS+E/I Configuration command set	23
4.1 Configuring the BlueRS+E/I after power on	23
4.2 Configuring the BlueRS+E/I with AT commands.....	24
4.3 Remote configuration using the BlueRS+Configurator commands	24
4.4 List of BlueRS+Configurator commands	25
5 Diagnostic and error messages.....	41
5.1 Error messages from AT command set.....	41
5.2 Bluetooth error codes.....	41
6 Regulatory Information.....	44
6.1 FCC Statement	44
6.2 Caution.....	44
6.3 FCC Warning	44
6.4 Copyright and Trademark Notices.....	45
7 History	46
8 Appendix	47
A1: Technical data BlueRS+E/I	47
A2: Mechanical dimensions of the module BlueRS+I	49
A3: BlueRS+I Interface Connector P1	50
A4: Pin out	51

1 Introduction

We are very pleased to see that you have bought a Arknav product and would like to express our appreciation.

This documentation is valid for the following models of the BlueRS+E/I product family

BlueRS+E Serial port adapter in a housing with internal antenna

BlueRS+I Serial port adapter module to plug into other hardware with local antenna

Software version V1.1.025 or later

1.1 Product description

The BlueRS+E/I is a Bluetooth adapter with the following functions.

The BlueRS+E/I connect devices with a **serial port** to any Bluetooth link. It gives access to other devices situated in the same Bluetooth area (piconet).

Data can be transmitted with the rates from 300 up to 230400 baud.

The connected serial device can drive the BlueRS+E/I by using

- asynchronous AT commands
- automatic connection setup
- accept incoming Bluetooth links.

The configuration of the BlueRS+E/I can be performed via the serial interface (local) or via the Bluetooth link (remote).

The following profiles are supported:

One serial profile for transparent data communication through the Bluetooth link.

A second serial profile for management access from another Bluetooth device using a Bluetooth link.

1.2 Safety

The BlueRS+E/I is conform to the European safety requirements IEC 60 950.

Please use only the delivered power supply or an original replacement from Arknav

BlueRS+E/I has been qualified as a product according to the Bluetooth qualification program.

2 Installation

2.1 Contents

This packet contains the following items:

Bluetooth serial adapter BlueRS+E or BlueRS+I
Mains plug power supply adapter for BlueRS+E
This user manual

2.2 Installation procedure

BlueRS+E:

To start using the BlueRS+E, please follow these steps:

Plug the BlueRS+E to the serial port (COM-port) of serial terminal equipment.

Connect the power supply to the BlueRS+E.

The green LED on the BlueRS+E will come on to indicate that the device has been powered up. After some seconds the green LED will start blinking to indicate power saving mode.

Optionally: Configure the BlueRS+E Bluetooth interface if needed. Configuration is required especially if you want to automatically connect to another Bluetooth device (set up the remote Bluetooth address).

The BlueRS+E is now ready for use with Bluetooth links, please refer to the next chapter for the configuration to use the terminal equipment together with the BlueRS+E.

BlueRS+I:

To use the BlueRS+I you need a mainboard with a fitting connector to plug in the BlueRS+I. Please refer to the technical details how to build such a connector.

The following chapters about using and configuring the BlueRS+E and BlueRS+I are identical for both products.

3 Using the BlueRS+E/I

Before using the BlueRS+E/I the address of another Bluetooth device has to be selected - if not predefined by factory – that shall be the communication partner in the Bluetooth link.

The compatible devices can be scanned using the configuration command "binq".

The found devices are listed in "binqlist". One Bluetooth device from that list has to be selected.

If you are using an automatic connecting mode the Bluetooth address has to be entered and stored using the configuration command "brad" (see BlueRS+E/I Configurator activation on page 23).

In addition to the selected Bluetooth address a PIN may be setup, if a restricted mode connection has to be setup (command "bpin" and "bsecout"/"bsecin"). This PIN has to be identical to the PIN used in the remote Bluetooth device.

You can select different operation modes for the BlueRS+E/I. These operating modes are used to control Bluetooth links and to configure the BlueRS+E/I.

Supported operating modes for Bluetooth link control:

- Automatic connecting after Power up.

- Automatic connecting controlled by control line DTR.

- Automatic connecting on activity on the serial input.

- Automatic accepting of incoming connections.

- Connection control using the asynchronous mode for devices that need the AT command set.

You can configure the BlueRS+E/I in the following ways:

- By using BlueRS+E/I Configuration commands entered by the locally connected PC.

- By using the AT command set entered by the locally connected PC.

- By using BlueRS+E/I Configuration commands entered via the Bluetooth link (remote configuration).

3.1 Automatic connection establishment

Automatic connection establishment is available in the following modes:

- . An automatic connection will be initiated when control line DTR is on.
- . An automatic connection will be initiated when a character is received on the serial port.
- . An automatic connection will be initiated independent of any status line – automatically after power up and initialization.
- . No connection establishment initiated by this module. Bluetooth connection requests from other Bluetooth devices will be automatically accepted (if compatible).

To enable automatic call you have to set BlueRS+E/I Configuration parameter "*cmds*" to 6, 7, 8 or 12 (see below).

cmds function

- 6 Automatic connection establishment when DTR is ON
- 7 Automatic connection establishment on any character received on serial port
- 8 Automatic connection establishment independent of any status line
- 12 No connection establishment initiated by this module

An established connection will be indicated by a status line (default: DCD). See also configuration commands "*cdcd*" and "*cdtr*".

If a connection cannot be established successfully an automatic retry will be started the duration of trying to establish the connection and the pause for next retry can be configured.

The Bluetooth devices to be accessed are taken from the parameter "*brad*", "*brad2*" and "*brad3*", they have to be set up to the Bluetooth device addresses of the remote Bluetooth devices. Additionally the server channel has to be set up if not fitting to the default (1), with the parameter *brsch* or using the address extension syntax for the address.

- cato n* call abort of a not successful call after *n* seconds.
- n = {3..255}*, default: **15** seconds.
- capa n* call pause for *n* seconds before next call attempt.
- n = {0..255}*, default: **3** seconds.

Hint: The configuration command "*idle*" can be used, to automatically disconnect after a predefined time without data transmission.

3.2 AT command set for BlueRS+E/I

All parameter can be changed by using an extended AT command set described in this chapter.

Please check if the factory setting will fit with your environment. The factory setting is described (highlighted) in the parameter list below.

If you want another configuration as set in the factory default setting, please do the following steps:

Plug the BlueRS+E to the COM-Port of a PC.

Connect the power supply to the mains socket.

Start a terminal emulation on your PC; please verify that the baud rate setting of the terminal emulation fits those of the BlueRS+E

Set up the parameter of the BlueRS+E from the terminal emulation and save the parameter using the AT command set.

Example:

To change the access mode on incoming connections to "bond unknown" please enter the following commands:

ATBSECIN=1** <↵> (perform authentication on connection setup)

AT&W <↵> (store the new configuration)

Leave your terminal emulation and start your application program.

With the exception of the command **A/** (Repeat command) all commands begin with the prefix **AT** and are terminated with <↵>. Corrections in a command line are done with <BACKSPACE>. A command line has a maximum of 80 characters. The command line is automatically cancelled by longer input. Blanks are ignored; capital/small letters are not significant.

The parameter settings of the BlueRS+E obtained when using the AT commands can be permanently stored (AT&W) and are not lost by resetting or by leaving the AT command mode.

To enter the AT command mode during an active data connection you must use the following sequence ("Escape sequence"):

At least 1 sec pause <+><+><+> 1 sec pause.

The time gap between all three plus signs may not exceed 1 sec.

The escape sequence is transmitted transparent to the remote device.

All commands and parameters marked as [deprecated] should not be used on new implementations they might disappear in future firmware releases.

Supported commands:

A/ Repeat last command line

This command repeats the commands of the last entered command line.

Note: No prefix **AT** is required.

A/

A Accept incoming call

Using this command you can accept an incoming call, if automatic call acceptance is not set (Register S0 = 0).

An incoming call is always displayed by the message “**RING**” or the code “**2**”, also if automatic call acceptance is selected.

Must be the last command in an AT command line.

CONF Enter BlueRS+E/I Configuration

Enters directly into the BlueRS+E/I Configuration, the configuration prompt “#” will be displayed. Leave the BlueRS+E/I Configuration with the command “quit” (or “exit” or “Go”).

ATCONF

&C DCD control

This command selects the behavior of the DCD control line from the BlueRS+E/I.

AT&C BlueRS+E/I control line DCD is always ON

AT&C1 DCD ON indicates Bluetooth connection is established (default)

AT&C2 DCD line follows DTR

AT&C4 DCD follows remote DCD

D Initiate Bluetooth link

This command addresses a Bluetooth device directly through its address or name. If a connection to a Bluetooth device requiring the restricted mode the PIN has to be set up using command AT**BPIN.

ATD <brad>[,cn][dx,sx,uy

brad: called Bluetooth remote device address (12 digits)

cn: Server channel for the requested service on remote device

dx: references called Bluetooth remote device number in *binqlist* (d01...d16)

sx: reference to remote device service number in *binqlist*

uy: with y=UUID of a service, if the remote device presents more than one service with the same UUID the last one is selected (for a list of valid UUIDs see chapter 3.3 "Table for coding Bluetooth services")

This command must be the last command in an AT command line. Any character input while the BlueRS+E/I is dialing will cancel the dialing procedure.

Examples:

ATD 0080371443AB Connect to Bluetooth device 0080371443AB

ATD d1 Connect to 1st Bluetooth device in *binqlist* (server channel number defined in *brsch*)

ATD d3,u1101 Connect to Bluetooth device to service with UUID1101 (serial port) of device d3

The characters W, >, P, T, ' ', '!', /, R, ^, !, L, @, (,), '-', ' ' (lower and upper case) are ignored within an dialstring.

Note:

The remote Bluetooth device has to be determined before issuing this link request. This can be done in the following ways:

- Get it manually by reading from the sticker of the remote Bluetooth device.
- Inquire the address and service by using the commands AT**BINQ=1 and AT**BINQLIST
- Give the BlueRS+E/I about 10 seconds after reset to initialize before issuing the first command.

&D DTR control

This command selects the behavior of the BlueRS+E/I, when the DTE control line DTR changes from ON to OFF.

- AT&D DTE control line DTR setting is ignored
- AT&D2 DTE control line DTR is evaluated: dropping the DTR line by the DTE will disconnect an existing Bluetooth link.
An incoming call will be accepted only with DTR active.
- AT&D4** DTE control line DTR is partly evaluated:
 - dropping the DTR line by the DTE will disconnect an existing Bluetooth link (default).
 - An incoming call will be accepted independent of DTR status.

E Local echo

This command selects the local echo in command mode.

- ATE No local echo
- ATE1** Local echo on in command phase (default)

&F Load factory defaults

Factory default will be loaded. (For storing in non volatile memory please use the command AT&W).

- AT&F setup all parameter concerning data port.
- AT&F1 setup all parameter including Bluetooth specifics and passwords.

H Disconnect

This command disconnects existing Bluetooth connection, after issuing the escape sequence (see page 5).

ATH

I Display version information

Displays different information about version number and settings:

ATI	Returns the "Modem"-type; name of the terminal adapter ("BlueRS+E" or "BlueRS+I")
ATI1	Returns "0"
ATI2	Returns "OK"
ATI3	Returns version string: "V1.xyz"
ATI4	Returns manufacturers name
ATI5	Returns "OK"
ATI6	Returns copyright string
ATI7	Returns "OK"
ATI8	Returns "ERROR"
ATI9	Returns "OK" (Plug&Play ID-Request not supported)
ATI77	Returns Bootloader version string
ATI99	Returns software creation date

&K Flow control

This command selects the flow control behavior of the BlueRS+E/I while in data communication phase.

AT&K	No local flow control between the DTE and BlueRS+E/I is used
AT&K3	Local flow control is set to hardware handshake RTS/CTS (default)

O Return to online state

If the BlueRS+E/I is in command mode after issuing an escape sequence out of an existing connection, ATO brings the BlueRS+E/I back to data phase.

It must be the last command in AT command line.

ATO

Q Suppress results

With this command result codes or messages can be suppressed.

ATQ	Returns status - codes after command input (default)
ATQ1	No result codes are returned

&R CTS control

This command selects the behavior of the CTS control line from the BlueRS+E/I.

AT&R BlueRS+E/I control line CTS is following all changes of RTS
AT&R1 CTS is always ON (default)

S Display and set internal S register

ATSnn? Show actual values (decimal) of selected register *nn*
ATSnn=xxx Set selected register *nn* to the decimal value *xxx*.
 See S register definitions on page 18.

&S DSR control

This command selects the behavior of the DSR control line from the BlueRS+E/I.

AT&S BlueRS+E/I control line DSR is always ON (default)
AT&S1 DSR ON indicates Bluetooth link is established

V Result format

ATV Result is presented as numbers (followed by < >)
ATV1 Result is presented as text (default)

&V Display configuration

AT&V Displays the actual configuration of AT command setting
AT&V1 Displays the actual configuration of extended AT command setting

W Extended result codes

ATW Result is presented without extended result codes.
ATW1 Result is presented with extended result codes, Result messages include error causes.

&W Store active configuration

The active configuration will be stored in non volatile memory.
AT&W

Z Load stored settings

The active configuration will be reset to the stored configuration.
Must be the last command in an AT command line.
ATZ

****DBITS** Number of data bits x asynchronous chars (7,8)

Number of data bits x for asynchronous character (7, default: 8).
AT**DBITS= x

****PRTY** Set parity of asynchronous characters

This command selects the parity for asynchronous characters.

0: no parity; 1: even parity; 2: odd parity

AT**PRTY=0	No parity (default)
AT**PRTY=1	Odd parity
AT**PRTY=2	Even parity

3.2.1 Bluetooth specific AT commands

****BINQ [mode]** Search Bluetooth devices

With this request the automatic search and service of all discoverable Bluetooth devices will be initiated.

As a result the creation of the list *binqlist* will be initiated. The list can be read out using the command `at**binqlist`. If the inquiry has not been terminated while issuing the command `at**binqlist`, the BlueRS+E/I will return "inquiry active".

The entries contain the Bluetooth device address, the Bluetooth device names and available services (profiles).

The creation of this list may take up to 20 seconds due to the reaction time of the accessible Bluetooth devices; a maximum of 16 Bluetooth devices can be listed.

When issuing the command "`at**binq 1`" the command terminates with "OK" when the search process is finished. During the search process the BlueRS+E/I reports the device and service information.

Note: The performance of the command is influenced by the parameters BINQND and BINQSD.

Example: `at**binq` request Bluetooth devices with name and service
 Response: OK

****BINQLIST** Show inquired Bluetooth devices

With this request the list of found Bluetooth devices will be returned, the entries show the Bluetooth device address and the Bluetooth device name requested by the command `at**binq`. For every Bluetooth device in addition the available services (profiles) will be shown (for a list of valid services see chapter 3.3 "Table for coding Bluetooth services").

These entries can be accessed by the selector *d1...dn* to address the Bluetooth device and the selectors *s1...sn* to address the Bluetooth devices service channel.

A maximum of 16 Bluetooth devices will be displayed.

Example: at**binqlist
Responses:

d01: <bradr1> <cod1> <brname1>
s01: <service1> <server channel> <bsname1>
s02: <service2> <server channel> <bsname2>
d02: <bradr2> <cod2> <brname2>
s01: <service1> <server channel> <bsname3>

...
OK

or inquiry active if the search initiated by at**binq
OK is still active
or list empty if no Bluetooth device found
OK

bradr found Bluetooth remote device
address (12 digits)
cod class of device
brname found Bluetooth remote device
name
service coding of service type
server channel used channel number for service
type
bsname used service name for service type

****BINQDEL** <dx>,[sy] Delete remote device or service

To delete a remote device or service from the binqlist in BlueRS+E/I you have to issue the command "AT**BINQDEL".

Example: at**binqdel d1 delete device d1
Response: OK
at**binqdel d1,s2 delete service s2 of device d1
Response: OK

****BINQSERV <brad>| <dx>** Discover services of device

Performs a service discovery on a single device.

brad: Bluetooth remote device address (12 digits)

dx: References Bluetooth remote device number in binqlist (d01...d16)

The commands needs a Bluetooth device address or a device selector dx from the binqlist as a parameter.

The information gathered is responded immediately and inserted into the binqlist.

Example: at**binqserv d03 get service information for device d03
 Response: d03: <bradr1> <cod1> <brname1>
 s01: <service1> <server channel> <bsname1>
 s02: <service2> <server channel> <bsname2>
 OK

****BINQND <mode>** Request device name during device search

If the parameter BINQND is set to 1, a name request is performed on each inquired device during execution of the BINQ command.

If the parameter is set to 0 name are not requested.

default: **1** – names are requested from remote device

Example: at**binqnd 1
 Response: OK

****BINQSD <mode>** Discover services during device search

If the parameter BINQSD is set to 1, a service discovery is performed on each inquired device during execution of the BINQ command.

If the parameter is set to 0 services are not discovered.

default: **0** – do not discover services

Example: at**binqsd 1
 Response: OK

****BDINQ** Inquire Bluetooth devices [deprecated]

With this request the automatic scan of all discoverable Bluetooth devices will be initiated.

As a result the creation of the list *bdlst* will be initiated. The list can be read out using the command `at**bdlist`. If the Inquiry-scan has not been terminated while issuing the command `at**bdlist`, the BlueRS+E/I will return "inquiry active".

The entries contain the Bluetooth device address, the Bluetooth device names and available services (profiles).

The creation of this list may take up to 20 seconds due to the reaction time of the accessible Bluetooth devices; a maximum of 16 Bluetooth devices can be listed.

When issuing the command "`at**bdinq 1`" the inquiry scan will only request the Bluetooth addresses, name and service inquiry will not be performed.

Example: `at**bdinq` request Bluetooth devices with name and service
 Response: OK
 `at**bdinq 1` request Bluetooth device addresses only
 Response: OK

****BDLIST** Show inquired Bluetooth devices [deprecated]

With this request the list of found Bluetooth devices will be returned, the entries show the Bluetooth device address and the Bluetooth device name requested by the command `at**bdinq`. For every Bluetooth device in addition the available services (profiles) will be shown.

These entries can be accessed by the selector *d1...dn* to address the Bluetooth device and the selectors *s1...sn* to address the Bluetooth devices service channel.

3.2.2 AT command S register set

- S0** 0: No automatic call acceptance, acceptance of an incoming call is controlled by the data terminal (command ATA after RING)
1: Immediate call acceptance by the terminal adapter (default)
2..n: Call acceptance through the terminal adapter after n "RING" messages.
- S2** Escape Character (default = 43h)
- S3** Carriage Return Character (default = 13)
- S4** Line Feed Character (default = 10)
- S5** Backspace Character (default = 08)
- S7** Wait time for Carrier (sec) (default = 30 sec)
- S9** Enable PNP functionality for Windows95 (default=1, enabled)
- S91** 0: default
1: all unknown AT commands will be answered with OK.
2: Windows 2000 compatibility: some AT commands will be answered with OK, unknown AT commands will be answered with OK.

3.2.3 AT result codes

Result codes (numerical and verbose):

Code	Text	Meaning
0	OK	Command completed
1	CONNECT < <i>radr</i> >	Connection established
2	RING < <i>radr</i> >	Indicates an incoming call (Link request received)
3	NO CARRIER < <i>berr</i> >	No synchronization (<i>berr</i> = BT error cause)
4	ERROR	Illegal command or error that can not be indicated otherwise
6	NO DIALTONE < <i>berr</i> >	No access to Bluetooth? network (<i>berr</i> = BT error)
7	BUSY < <i>berr</i> >	Number engaged (<i>berr</i> = BT error cause)
8	NO ANSWER < <i>berr</i> >	No connection; addressed Bluetooth device cannot be reached (<i>berr</i> = BT error cause)

<*radr*> = Address of the remote device
the display of the remote device address must be enabled with the command ATW1.

Error cause display:

<*berr*> = Bluetooth release (error) cause, hexadecimal
Example: NO CARRIER <0104>

In AT command mode, error cause display (does not belong to the AT command standard) can be turned on by issuing the command ATW1 . The shown error causes use the coding defined by the Bluetooth definition (see page 41).

3.3 Table for coding Bluetooth services

List of Bluetooth services (profiles/UUIDs):

Code	Text	Meaning
1101	SerialPort	Serial port, serial data link without any restriction
1102	LANAccessUsingPPP	Lan Access with PPP protocol
1103	DialupNetworking	Dial Up Networking to establish switched connections to the ISDN or PSTN
1104	IrMCSync	
1105	OBEXObjectPush	OBEX Object Push
1106	OBEXFileTransfer	OBEX Filetransfer
1107	IrMCSyncCommand	
1108	<i>Headset</i>	<i>Headset access via Bluetooth</i>
1109	Cordless Telephony	
1100	Intercom	
1111	Fax	Fax
1112	<i>HeadsetAudioGateway</i>	<i>Headset Gateway for audio signals</i>
1113	WAP	
1114	WAP_CLIENT	

3.4 Power down modes

To reduce power consumption of the BlueRS+E/I power down modes can be activated automatically by the BlueRS+E/I (controlled by parameter settings).

If no Bluetooth connection is established, the following states are implemented; the activation of these states can be controlled by the parameter *bpsm* and *pwd*.

3.4.1 Deep Sleep state

The Bluetooth RF is completely deactivated; no paging requests from other Bluetooth devices will be recognized. Only rising control line DTR will activate the BlueRS+E/I and may initiate a Bluetooth link dependent on other parameters.

Example:

cmds=8 establish BT-Link after rising DTR

pwd=1 enable power down mode

bpsm=0 disable paging modes in power down

Note: In Deep Sleep state the AT command set is not active, CTS line is low.

3.4.2 Power down state

The Bluetooth RF is activated every 1.25 seconds, paging requests from other Bluetooth devices will be recognized after that intervals and accepted if allowed. Additionally rising control line DTR will activate the BlueRS+E/I and may initiate a Bluetooth link dependent on other parameters.

Example1:

cmds=8 establish BT-Link after rising DTR

cdtr=2 DTR controlled BT-Link

pwd=1 enable power down mode

bpsm=2 enable paging mode in power down

Example2:

cmds=12 accept BT-Link

cdtr=4 accept BT-Link independent of DTR status

pwd=1 enable power down mode

bpsm=2 enable paging mode in power down (inquiry will not be answered)

Note: In Power down state the AT command set is not active, CTS line is low.

1.05/01/2005 BlueRS+E/I manual

3.4.3 Idle state

No power down mode activated.

All functionality is available immediately including connection control using AT command set.

Example:

cmds=0 establish BT-Link using AT command or accept incoming BTLINKs

cdtr=4 accept BT-Link independent of DTR status

pwd=0 disable power down mode

bpsm=3 enable paging and inquiry modes

BlueRS+E/I manual 1.05/01.2005

3.5 Power consumption

The following values are approximate power consumption values in the different states for the BlueRS+E and BlueRS+I:

Power Current Consumption

Condition BlueRS+E BlueRS+I

Deep sleep Hw V1: ~23 mA

Hw V2: ~ 4 mA

~ 0.7 mA

Power down average ~24 mA ~ 2.5 mA

Idle, all functions available, no

Bluetooth link

~ 45 mA ~ 22 mA

Bluetooth connected, no data traffic,

(Master / Slave)

~ 47 / 58 mA ~ 24 / 35 mA

Bluetooth connected, data traffic 115

kbit/s

~ 70 mA ~ 46 mA

Please note, that power consumption is additionally dependent on the interfacing of the serial interface and status lines (output load).

1.05/01/2005 BlueRS+E/I manual

4 BlueRS+E/I Configurator command set

The settings of the BlueRS+E/I for the serial interface and the Bluetooth interface are called configuration. The BlueRS+E/I is delivered with a set of pre-set values. In the following section it will be shown how, by using the configuration commands, you can examine the configuration of the BlueRS+E/I and if necessary change it. The values can be stored in non volatile memory; this means they'll remain unchanged even if the power supply is disconnected.

You can configure the BlueRS+E/I in the following ways:

- . By using BlueRS+E/I Configurator commands entered by a locally connected PC.
- . By using the AT command set entered by a locally connected PC.
- . By using BlueRS+E/I Configurator commands entered via the Bluetooth link (remote configuration).

The BlueRS+E/I Configurator can be entered in the following ways:

- . By using a special command from the asynchronous dialup command interface (AT: "ATCONF").
- . Remote via a Bluetooth connection from another Bluetooth device.
- . By the escape sequence in power up phase if enabled (rsttim>10, rstmsg=1).

4.1 Configuring the BlueRS+E/I after power on

. Connect the PC's COM port to the DTE interface of the BlueRS+E/I.
. Start a terminal emulation program (i.e. Hyper-Terminal) with the following settings:
9600 Baud, 8 databits, No Parity (**8N1**)

. Connect the BlueRS+E/I to the mains by the mains plug adaptor
. Wait until LED 2 starts blinking (after about 5 sec, see config cmd "rsttim") and the message to enter the config sequence is displayed:

"+++ Press <CR>,<CR>,<ESC>,<ESC> to enter BlueRS+Configurator +++"

. Type in quickly within 2 seconds after the message appears: <RET> <RET>
<ESC> <ESC>, to call up the BlueRS+Configurator.

. The BlueRS+Configurator acknowledges by giving a welcome string and a "#" as the prompt character. Now you can work with the BlueRS+Configurator by using the configuration commands (see page 25).

. Setup the parameter for the BlueRS+E/I from your terminal program and store them.
Example:

To **set** the baudrate to 9600 baud, please enter the following commands:

br=4< > (set baudrate to 9600 baud)

save< > (store the new configuration)

BlueRS+E/I manual 1.05/06.2004

quit< > (leave the BlueRS+Configurator and activate the new value settings)

Hint: The active set of parameters can be displayed on screen by the BlueRS+Configurator with the command "**show**< >".

. Leave the terminal program and start your application.

Now you can use the BlueRS+E/I with the new set of parameters by running the needed PC program.

4.2 Configuring the BlueRS+E/I with AT commands

To execute one BlueRS+Configuration command *cmd* out of the AT command mode you have to issue the command: "at***cmd*".

To call up the BlueRS+Configurator please use the command "atconf".

You can leave the BlueRS+Configurator by the command "quit" (or „exit“ or „go“).

4.3 Remote configuration using the BlueRS+Configurator Commands

The BlueRS+E/I to be configured is referred here as "*remote* BlueRS+E/I".

The BlueRS+E/I to configure is referred as "*local* BlueRS+E/I".

Please make sure that the *remote* BlueRS+E/I to be configured at the other end is powered up.

- Connect the PC's com-port to the DTE interface of the *local* BlueRS+E/I.
- Connect the power supply to the mains socket.
- Start a terminal emulation program (i.e. HyperTerminal)
- Configure the *local* BlueRS+E/I with the special service channel 30

(brsch=30).

- Set up a Bluetooth-Link to the *remote* BlueRS+E/I to be configured by using the command: ATD<*brad*>.

The called BlueRS+Configurator acknowledges by requesting the remote password. Please enter the correct password (default: no password, just return). Now you can work with the BlueRS+Configurator by using the BlueRS+Configurator commands (see page 23).

- Configure the parameter for the *remote* BlueRS+E/I from your terminal program and store them (if wanted). (See page 25).

Hint: The active set of parameters can be displayed on screen by the BlueRS+Configurator with the command "**show**".

If necessary the *remote* BlueRS+E/I can be reset using the command "**reset**".

- Hang up the Bluetooth connection by leaving the BlueRS+Configurator using the command **quit**.

Leave your terminal program. After the next reset the changes will be active.

- Restore the server channel to the desired value, default to 1 (brsch=1).

Now the configured *remote* BlueRS+E/I with the new set of parameters can be used by running the needed PC program.

4.4 List of BlueRS+Configurator commands

The BlueRS+Configurator commands typed in must have the correct syntax and be complete, including all blanks. Capital/small letter use is not important. The entry is not case sensitive.

The bolded values are factory defaults. The usage is:

[?]<**command**>[=**parameter**]

Example to **set** the baudrate to 9600 baud:

br=4

Example to **show** the selected baudrate:

br

Example to **show all** selectable baudrates:

?br

To get an overview about the commands of your BlueRS+E/I some major commands here as a preview:

show show the usually used parameter

showall show all changeable parameter

quit leave BlueRS+Configurator

help show all available commands

defa 1 setup factory default parameter set

save store parameter non volatile

BlueRS+E/I manual 1.05/01.2005

at.sx AT command parameter set

AT command set only:

Handle AT specific settings.

Show and change AT S registers by entering the new value.

at.s0 show setting of S0-Register

at.s0=1 set Register S0 to 1

bacctab Show bonding information [deprecated]

To show the bonding information (setup due to a successful restricted connection) within the BlueRS+E/I you have to issue the command "AT**BACCTAB". The BlueRS+E/I can store up to 4 bonds.

If all 4 entries are used a new bond will overwrite the oldest one.

Example: at**bacctab

Response: 1: used: YES BD: 00803714ECA4 name: <name>

2: used: YES BD: 008025000105 name: <name>

3: used: NO

4: used: NO

OK

bclass Set Bluetooth class of device

Allows the manipulation of the Bluetooth Class of Devices/Service

The default setting is 1F00 = no services class, unspecified device class

bcrypt Switch encryption on or off

Enable or disable the encryption of the information transferred via Bluetooth.

Please note the Bluetooth connection must be authenticated (see parameter BSECOUT,BSECIN) to allow encryption.

Possible values are:

0: encryption switched off

1: encryption enabled

Example: at**bcrypt 1

Response: OK

1.05/01.2005 BlueRS+E/I manual

bdel Delete pairing information [deprecated]

To delete the pairing information (setup due to a successful restricted connection) within the BlueRS+E/I you have to issue the command "AT**BDEL 1". The paired Bluetooth device can be read out by the command "AT**BACCTAB".

Example: at**bdel 1

Response: OK

bpin Bluetooth device PIN (Passkey)

Set the PIN for establishing a connection in the restricted mode by the command "AT**BPIN=<old_pin>,<new_pin>".

This PIN is always checked if

- the BlueRS+E/I is set to restricted mode

- the BlueRS+E/I is not set to restricted mode and the other Bluetooth device is set to restricted mode.

The PIN has a maximum length of 16 alphanumeric characters, factory default: **0000**.

Note: You should prefer to use a passkey composed from decimal digits. You can not ensure that a remote device with limited user interface capabilities supports alpha characters.

To reset the PIN to factory default please use the command AT&F1 (all parameters will be set to factory default).

Example: at**bpin=0000,1234 set PIN to 1234 (old PIN was 0000)

Note: After a pairing has taken place (PIN successful exchanged) Bluetooth links can be established between these paired devices independent of the setting of the restricted mode and the PIN!

bnd <device>[,<passkey>] Bond with a Bluetooth device

This command initiates a bonding process with a remote Bluetooth device.

<device> may either be the device address of the remote device or the devices selector dxx from the binqlist.

The optional parameter <passkey> is the passkey used to generate the bond.

If <passkey> is omitted the passkey configured with the **bpin command is used.

If the bonding succeeded BlueRS+E/I responds “SUCCESS” otherwise “FAIL”

Example: at**bnd=010203040506,1234 bond with device with address 010203040506 and use 1234 as passkey

bndlist Show bonded device list

To show information about the devices bonded with the BlueRS+E/I you have to issue the command AT**BNDLIST”.

Example: at**bndlist

Response: b01: <bradr1> <bname1>

...

OK

bnddel <bndsel> Delete bonding information

To delete the bonding information held within the BlueRS+E/I you have to issue the command “AT**BNDDEL <bndsel>”. The bonded Bluetooth devices can be read out by the command “AT**BNDLIST”. “AT**BNDDEL all” deletes all bonded devices.

Example: at**bnddel b1

Response: OK

bnds <mode> Set the storage mode for bonds

If the parameter BNDS is set to 1, bonding information (link keys) are stored permanently in the NVRAM of the BlueRS+E/I.

If the parameter is set to 0 bonds persist for the duration of the authenticated connection.

Example: at**bnds 1
Response: OK

bpsm Set scanning capability

This parameter controls the visibility and the ability to be connected and the reaction to paging and/or inquiry requests.

If set to 0 all paging/inquiry requests from other Bluetooth devices will be ignored, the RF receive part of the BlueRS+E/I is disabled.

Possible values are:

0 : Page scan and inquiry scan are disabled (the BlueRS+E/I is not connectable and not discoverable)

1 : Inquiry scan is enabled (the BlueRS+E/I is discoverable, but not connectable)

2 : Page scan is enabled (the BlueRS+E/I is connectable, but not discoverable)

3 : Page scan and inquiry scan are enabled (the BlueRS+E/I is connectable and discoverable, default)

Example: at**bpsm=2 enable page scan, but do not answer on inquiry requests

bpsrm Set the page scan repetition mode

This parameter allows the modification of the page scan repetition mode of the BlueRS+E/I.

Possible values according to the Bluetooth baseband specification are:

0 : R0 - continuous scan

1 : R1 - 1,28 sec's interval 11,25 ms window (default)

2 : R2 - 2,56 sec's interval 11,25 ms window

Continuous scan decreases the connect time down to about 200 ms:

R0: about 200 ms

R1: about 2,2 sec

R2: about 3,5 sec

The BPSRM should be set to the same value for the scanning and the paging device.

BlueRS+E/I manual 1.05/01.2005

Example: at**bpsrm=0 set page scan repetition mode to R0 – continuous.

Note: Setting the page scan repetition mode to continuous scan increases the power consumption significant (additional current of about 45 mA).

bsecin <mode> Authorization mode for incoming connections

The BSECIN parameter configures the authorization behavior of the BlueRS+E/I on incoming connections.

<mode> mode name behavior

0 bondable accept bond request from remote device

no active authentication (default)

1 bond unknown perform authentication on connection setup, if not bonded with remote device perform a bonding

2 bond always always perform a bonding

3 bonded only accept only connections from bonded devices, authenticate the link authorization

4 rebond always accept only connections from bonded devices, always perform a bonding

5 do not connect

bsecout <mode> Authorization mode for outgoing connections

The BSECOUT parameter configures the authorization behavior of the BlueRS+E/I for outgoing connections.

<mode> mode name behavior

0 bondable accept bond request from remote device no active authentication (default)

1 bond unknown perform authentication on connection setup, if not bonded with remote device perform a bonding

2 bond always always perform a bonding

3 bonded only accept only connections from bonded devices, authenticate the link authorization

4 rebond always accept only connections from bonded devices, always perform a bonding

5 do not connect

boad Bluetooth own device address

With this command you can read out the own Bluetooth device address.

This value cannot be changed.

Example: AT**BOAD

bname BlueRS+E/I own device name

This command defines the device name. bname is shown on a remote Bluetooth terminal device during a service discovery sequence It is a string constant according to V.250.

Example: at**bname show own device name

at**bname=<rs+name> set own device name to rs+name

bofcon Set fast connection mode

With this parameter the fast connection mode for outgoing calls can be switched on and off. The BlueRS+E/I uses a different page mode to establish the Bluetooth connection to the remote device and decreases the timeout for a unsuccessful paging.

Note: The remote device must be configured to use page scan mode R0 (parameter bpsrm) to achieve the full speed advantage.

Example: at**bofcon=1 enable the fast connection mode.

bosch Set own server channel number

Set up server channel number of the serial service supplied by the local device.

The channel number is used for incoming connections only.

Note: The server channel 30 is reserved for the remote configuration access, do not use it for the serial port service.

bosrv Own service (profile) UUID

Defines the service the BlueRS+E/I announces to the world. “bosrv” influences the type that is shown on a remote Bluetooth terminal device during a service discovery sequence. The value must be entered as a hex number. default:

0x1101 serial port

Example: at**bosrv set own service to DialUp networking

brad, brad2, brad3 Bluetooth remote device address

With this parameter you can setup up to 3 Bluetooth addresses of remote Bluetooth devices, that should be connected using an automatic link setup. The BlueRS+E/I will try to connect the device with address “brad” first, if that fails because the device is busy or unreachable it tries to connect the device “brad2” afterwards “brad3”.

Then the sequence starts again with “brad”

The address can be any dial string as specified for the command ATD.

The address can be deleted using the command brad -.

Example: brad=0080371443AB

brbd Displays connected device address

This command displays the device address of the connected Bluetooth device.

This value cannot be changed.

Example: at**brbd show connected device address

brname Displays connected device name

This command displays the device name of the connected Bluetooth device.

This value cannot be changed.

Example: at**brname show connected device name

brsch Set remote Bluetooth server channel

Set up server channel of the remote Bluetooth module, to which the Bluetooth link shall be established.

The own server channel number can be changed with parameter bosch. Remote management between BlueRS+E/I is achieved using the server channel 30. default: 1

Example: at**brsch=1

bsname BlueRS+E/I service name

Defines the service name of the BlueRS+E/I. "*bsname*" is shown on a remote Bluetooth terminal device during a service discovery sequence.

default: BlueRS+E/I serial port

Example: at**bsname at**bsname=<rs+srvname> set own service name to rs+srvname

brestr Set restricted mode [deprecated]

Control the security behavior of the BlueRS+E/I.

When set to 1 the bonding information from the list of bonded devices or the passkey stored with parameter bpin will be used for authentication.

When set to 2 connections are allowed with bonded devices only. The passkey will not be used to authenticate the remote device.

The PINs of two Bluetooth devices have to set to the same value, if one of these devices allows only restricted connections. If a restricted connection has been established one time between two Bluetooth devices these devices know each other and are called as "bonded" (see command "AT**BACCTAB" for information about the bonded Bluetooth devices).

After a bonding has taken place Bluetooth links can be established between these bonded devices independent of the setting of the restricted mode!

BlueRS+E/I manual 1.05/01.2005

To delete the bonding information within the BlueRS+E/I you have to issue the command "AT**BDEL".

pwd Set power down mode

Setting this parameter to 1 allows the BlueRS+E/I to achieve power down state.

This leads to reduced power consumption if no Bluetooth link is established.

The power down state is achieved automatically (after approx. 1-2 seconds) if a Bluetooth link is disconnected and the line DTR is set to low.

Rising DTR will signal the BlueRS+E/I to leave power down, all functions will be available.

Please note, that in power down state the AT command handler is not available.

Possible values are:

0 : power down not allowed (default)

1 : power down state will be achieved automatically

Example: at**pwd=1 enable power down mode

br Baudrate asynchronous

Selection of the asynchronous baudrate for the DTE interface

1: 1200 bits/s

2: 2400 bit/s

3: 4800 bit/s

4: 9600 bit/s

5: 19200 bit/s

6: 38400 bit/s

7: 57600 bit/s

8: 115200 bit/s (default)

9: 230400 bit/s

20: 300 bit/s

21: 600 bit/s

26: 10400 bit/s

cato Call timeout to abort

Time to abort a call if not successful connected after n seconds.

$n = \{3..255\}$, default: **15** seconds.

1.05/01.2005 BlueRS+E/I manual

capa Call pause

Automatic call: Set a call pause for n seconds before next call attempt.

$n = 0$: no call retry, default: **3** seconds.

ccts CTS control

CTS control

0 : CTS follows local RTS

1 : CTS always ON (default)

2 : CTS follows local DTR

3 : CTS follows remote CTS line status

cdcd DCD control

DCD control

0 : DCD always ON

1 : DCD indicates a Bluetooth connection (default)

2 : follows local DTR

5 : follows remote DCD

6

cdsr DSR control

DSR control

0 : DSR always ON (default)

1 : DSR indicates a Bluetooth connection

4 : DSR follows remote DSR line status

BlueRS+E/I manual 1.05/01.2005

cdtr DTR control

Usage of DTR to control a Bluetooth connection

0 : No control:

Incoming calls will be accepted independent of DTR status;

DTR drop does not disconnect an active connection.

2 : DTR off disconnects

Incoming calls will be accepted only when DTR is ON;

DTR drop disconnects an active connection.

4 : DTR ignore and DTR drop disconnects (default)
Incoming calls will be accepted independent of DTR status;
DTR drop disconnects an active connection.
7 : Reset device
DTR drop initiates a software reset.

cmds Command set

Command set for connection control

0: AT command set (default)

6: Automatic connection establishment when DTR is ON.

7: Automatic connection establishment when char is received.

8: Automatic connection establishment independent of any status line.

12: No connection establishment initiated by this module.

Note: For details see the appropriate chapters.

cri RI control

RI control

0 : RI is set with an incoming Bluetooth link request (default)

1 : RI follows remote RI line status

defa Default settings

Sets up factory default parameter setting.

defa 0: setup all parameter concerning data port

defa 1: setup all parameter to factory defaults including Bluetooth parameter.

dbits Asynchronous databits

1.05/01.2005 BlueRS+E/I manual

Number of data bits asynchronous chars (default: 8) **7,8**

flc Flow control

Flow control to DTE

0 : No flow control

3 : Hardware flow control RTS/CTS (default)

7 : RTS to remote RI

flash Load new firmware

This commands loads new firmware into the BlueRS+E/I. The actual firmware will be overwritten.

The firmware will be stored into the used part of the flash memory. While uploading the following checks will be performed:

- File transfer protocol is XMODEM1K
- An overall firmware checksum is used.

- The firmware type written in the module header of the firmware must be compatible to the hardware- and allowed firmware type (stored inside the Bootloader).

This command is available only via the local serial port.

idle Idle data timeout

Timer to disconnect the Bluetooth link after inactivity on the serial line (sec).

0: inactive (default)

1..n: delay time to disconnect in seconds (1..255).

load Load stored parameter setting

All parameters stored in non volatile RAM will be loaded.

prty Asynchronous parity

Parity of asynchronous character (default: no parity)

0 : No parity; **1** : Odd parity; **2** : Even parity

quit, exit, go Activate parameter changes

BlueRS+E/I manual 1.05/01.2005

Activates the actual parameter settings and leave the BlueRS+Configurator (without storing the parameter in non volatile memory).

rbaccl Remote config port access level

Defines the accessibility and visibility of the Bluetooth remote configuration port. The following values are applicable:

0 config port is not accessible nor visible

1 config port is accessible but not visible

2 config port is accessible and visible

rbsname Remote config port service name

Defines the service name of the Bluetooth remote configuration port. “*rbsname*” is shown on a remote Bluetooth terminal device during a service discovery sequence.

default: config port

Example: at**rbsname

at**rbsname=<*rs+config*> set own device name to *rs+config*

rpwd Remote port config password

Sets password for remote configuration to *nn* (1..32 chars)

AT**RPWD=*nn*

Default: empty, just press return key.

1.05/01.2005 BlueRS+E/I manual

rpc Remote port config control

Bluetooth provides the feature to control serial port parameters like baudrate, parity etc. from the remote side. To distinguish if a device is the Master regarding RPC (settings are provided by the DTE) and which one is the Slave (gets its settings via the Bluetooth link) the parameter *RPC* is used.

RPC uses a single numeric parameter value, the default is 0 = Master mode. Any value different from 0 places the BlueRS+E/I in slave mode.

To facilitate a finer setting each bit of the *RPC* value has a control function for one port setting. If the bit is set the settings follows the remote setting (slave mode) and the corresponding local parameter is used as initial value and as setting in command mode (no Bluetooth link active).

bit function corresp. Parameter

0 baudrate br

1 number of data bits dbits

2 number of stop bits sbits

3 parity type prty

4 flow control flc

reset Reset BlueRS+E/I

Resets the whole functionality of the BlueRS+E/I by a forced hardware reset (like Power off / on).

Refer also to parameter rsttim.

rsttim Startup timer

Startup delay timer after reset. Within this period the configuration can be entered after reset.

1 .. 255 : reset phase in 100 milliseconds, default: **40** (4 seconds)

save Store parameter changes

Stores the actual set of parameters in non volatile memory.

BlueRS+E/I manual 1.05/01 2005

sbits Number of stop bits

Number of stop bits of asynchronous character

1 : One stopbit (default); **2** : two stopbit

show Show parameters

Displays the actual set of parameters

showall Show all parameters

Displays the all accessible parameters

txfwd Timer for data forwarding

If no character is entered within the defined period, the received data will be transmitted to the Bluetooth link.

0 : minimum delay time (appr. 10 ms, default)

1..n: delay time in 50 ms ticks.

Note: Valid for AT command set only.

ver Show version string

Displays detailed information about the software version and BlueRS+E/I type.

verb Show version string of Bootloader

Displays detailed information about the software version of the Bootloader.

<cmd>? More information for one command

Displays the allowed values for one selected command *<cmd>*

1.05/01.2005 BlueRS+E/I manual

5 Diagnostic and error messages

5.1 Error messages from AT command set

When the extended result messages are selected using the command ATW1

Bluetooth error codes are displayed in addition to the standard AT result messages.

Bluetooth error codes are always coded as *<xxxx>*. The meaning can be taken from the following tables Bluetooth error codes (see page 41).

5.2 Bluetooth error codes

Note: error codes marked with (i) are internal errors.

Error cause hexadecimal

Meaning Translation to AT result codes

0x0000 no error, no explanation 3

0x0001 driver and application version mismatch 3

0x0002 application id provided is not correct 3

0x0003 unknown message code in message 3

0x0004 not enough resources to complete request (out of descriptor etc)

3

0x0005 at least one parameter of the message is wrong 3

0x0006 no adapter plugged in 3

0x0007 too much outstanding messages in downstream direction

6

0x0008 driver is busy, repeat request later 6

0x0009 Error in message transport system (driver not correct installed?)

3

0x0101 (i) HCI_ERR_UNKNOWN_COMMAND 3

0x0102 (i) HCI_ERR_NOCONNECTION 3

0x0103 Bluetooth adapter crashed 3

0x0104/260 Remote Bluetooth device not found (wrong address?, out of range?)

8

0x0105 Authentication error (wrong pin code supplied?) 3
0x0106 (i) HCI_ERR_KEY_MISSING 3
0x0107 (i) HCI_ERR_MEMORY_FULL 3
0x0108/264 lost connection to remote Bluetooth device (out of range)
3
0x0109 max no of connections exceeded 6
0x010a max no of voice connections exceeded 6
0x010b (i) HCI_ERR_ACL_CONN_ALREADY_EXISTS 3
BlueRS+E/I manual 1.05/01.2005

0x010c (i) HCI_ERR_COMMAND_DISALLOWED 3
0x010d connection attempt by remote side rejected 3
0x010e connection attempt by remote side rejected 3
0x010f connection attempt by remote side rejected 3
0x0110 connection attempt by remote side timed out 8
0x0111 (i) HCI_ERR_UNSUPPORTED_PARAM_VALUE 3
0x0112 (i) HCI_ERR_INVALID_HCI_PARAMETER_VALUE 3
0x0113 connection terminated by remote side 3
0x0114 connection terminated by remote side 3
0x0115 connection terminated by remote side 3
0x0116 connection terminated by local side 3
0x0117 (i) HCI_ERR_REPEATED_ATTEMPTS 3
0x0118 authentication rejected by remote side 3
0x0119 incompatible remote Bluetooth adapter 3
0x011a unspecified error 3
0x011b (i) HCI_ERR_UNSUPPORTED_LMP_PARAMETER_VAL 3
0x011c master slave role switch not allowed 3
0x011d connect lost to remote Bluetooth adapter (link manager)
3
0x011e (i) (HCI_ERR_LMP_ERROR_TRANSACTION_COLLISION 3
0x011f (i) HCI_ERR_LMP_PDU_NOT_ALLOWED 3
0x0120 attempt to enable encryption failed 3
0x0121 information: unit key used 3
0x0122 (i) quality of service not supported. 3
0x0123 (i) HCI_ERR_INSTANT_PASSED 3
0x0124 (i) unit key not supported 3
0x0164 (i) HCI_ERR_ILLEGAL_HANDLE 3
0x0165 initialization of adapter failed (timeout) 6
0x0166 initialization of adapter failed (synchronization) 6
0x0201 (i) connection went to state pending 3
0x0202 protocol not supported by remote side 3
0x0203 connection refused due to security conditions 3
0x0204 out of resources 3

0x02ee remote side timed out 3
0x0301 version of remote SDP entity not compatible 3
0x0302 invalid service record handle 3
0x0303 invalid request syntax 3
0x0304 invalid size of pdu 3
0x0305 continuation state is invalid 3
0x0306 not enough resources to complete operation 3
0x0364 client received unhandled SDP opcode 3
0x0365 No answer from server(timeout) 3
0x0366 specified service not found 3
1.05/01.2005 BlueRS+E/I manual
0x0367 Syntax Error in Response from server 3
0x0464 Connection setup was rejected by remote side (DM),
i.e. the Pin exchange has failed in restricted mode
3
0x0465 Connection timed out (no response) 8
0x0466 Non Supported Command received (incompatible remote side)
3
0x0467 Illegal parameter 3
Note: error codes marked with (i) are internal errors.
BlueRS+E/I manual 1.05/01.2005

6 Regulatory Information

6.1 FCC Statement

This device complies with Part 15 of the FCC Rules and with RSS-210 of Industry Canada.

Operation is subject to the following two conditions:

- (1) this device may not cause harmful interference, and
- (2) this device must accept any interference received, including interference that may cause undesired operation.

6.2 Caution

Warning: Changes or modifications made to this equipment not expressly approved by Arknav may void the FCC authorization to operate this equipment.

6.3 FCC Warning

This equipment has been tested and found to comply with the limits for a Class B digital device, pursuant to Part 15 of the FCC Rules. These limits are designed to provide reasonable protection against harmful interference in a residential installation. This

equipment generates, uses and can radiate radio frequency energy and, if not installed and used in accordance with the instructions, may cause harmful interference to radio communications. However, there is no guarantee that interference will not occur in a particular installation. If this equipment does cause harmful interference to radio or television reception, which can be determined by turning the equipment off and on, the user is encouraged to try to correct the interference by one or more of the following measures:

- . Reorient or relocate the receiving antenna.
- . Increase the separation between the equipment and receiver.
- . Connect the equipment into an outlet on a circuit different from that to which the receiver is connected.

Consult the dealer or an experienced radio/TV technician for help

The radiated output power of BlueRS+E and BlueRS+I is far below the FCC radio frequency exposure limits. Nevertheless, the BlueRS+E and BlueRS+I shall be used in such a manner that the potential for human contact during normal operation is minimized
1.05/01.2005 BlueRS+E/I manual

6.4 Copyright and Trademark Notices

Products and brand names may be the trademarks or registered trademarks of their respective owners.

BlueRS+S

Add-On for User Manual

(Default parameters are printed in bold letters.)

****BSMODE** Sniff mode support level

AT-Syntax: **AT**BSMODE** | **AT**BSMODE=n**

Configurator-Syntax: **bsmode** | **bsmode=n**

Using this command sniff mode can be activated on the Bluetooth link. Sniff mode is used to reduce power consumption during an active Bluetooth connection.

With active sniff mode both connected devices enter sleep state regularly for short time intervals. The length of this interval is called "sniff timeout" and is negotiated between the connected devices. The maximum and minimum acceptable values for sniff timeout can be set using appropriate AT commands.

The sniff timeout value has an impact on the propagation delay and maximum throughput on the bluetooth link. Take note that to enter sniff mode both devices needs to support sniff mode.

ATBSMODE** Show sniff mode support level

ATBSMODE=0** No sniff support

ATBSMODE=1** Passive sniff support

ATBSMODE=2** Active sniff support

Passive sniff support means that the device accepts sniff requests from the remote device with an interval between the values of **BMINS** and **BMAXS**. To accept sniff requests from the remote device the parameter **BLINKP** has to be set to 4.

If active sniff support is enabled the device tries to setup a sniff interval with the value of **BMAXS**.

Note: The performance of the command is influenced by the parameters **BLINKP**, **BMINS** and **BMAXS**.

Examples:

ATBSMODE=1** and

ATBLINKP=4**

Sniff requests from remote devices will be accepted

ATBSMODE=2** and

ATBLINKP=1**

Device tries to initiate sniff mode on the Bluetooth link

**BROLE Device role

AT-Syntax: **AT**BROLE** | **AT**BROLE=n**

Configurator-Syntax: **brole** | **brole=n**

With this command the role the device requests for a new Bluetooth link can be defined.

AT**BROLE=0 Slave required

AT**BROLE=1 Slave preferred

AT**BROLE=2 Don't care

AT**BROLE=3 Master preferred

AT**BROLE=4 Master required

If the role is set to "required" the device enforces a switch. If this fails the link is disconnected.

"Preferred" means that the device tries to perform a switch but doesn't care about the result.

**BLINKP Link policy

AT-Syntax: **AT**BLINKP** | **AT**BLINKP=n**

Configurator-Syntax: **blinkp** | **blinkp=n**

With this command (bit mask) the link policy the device requests for a new Bluetooth link can be defined.

bit 0 ENABLE_SWITCH

bit 2 ENABLE_SNIFF

Examples:

AT**BLINKP=1 Device processes role switch from remote device

AT**BLINKP=4 Device processes sniff requests from remote device

**BMINS Minimum sniff interval

AT-Syntax: **AT**BMINS** | **AT**BMINS=n**

Configurator-Syntax: **bmins** | **bmins=n**

This command defines the minimum of accepted sniff interval in ms for a new Bluetooth link. The default value is **100** (ms). Possible values are profile dependent.

**BMAXS Maximum sniff interval

AT-Syntax: **AT**BMAXS** | **AT**BMAXS=n**

Configurator-Syntax: **bmaxs** | **bmaxs=n**

This command defines the maximum of accepted sniff interval in ms for a new Bluetooth link. The default value is **300** (ms). Possible values are profile dependent.

**BSUPTIM Supervision timeout

AT-Syntax: **AT**BSUPTIM** | **AT**BSUPTIM=n**

Configurator-Syntax: **bsuptim** | **bsuptim=n**

This command defines the supervision timeout the device requests for a new Bluetooth link. Possible values are between 1 and 65535 (in 0,625ms steps).

Note: The supervision timeout can only be set by the Piconet master.

Example:

AT**BSUPTIM=**32000** 20 secs.

Blue tooth serial :



Technical data Blue tooth serial

9 pin DSUB connector (male)

Pin out :

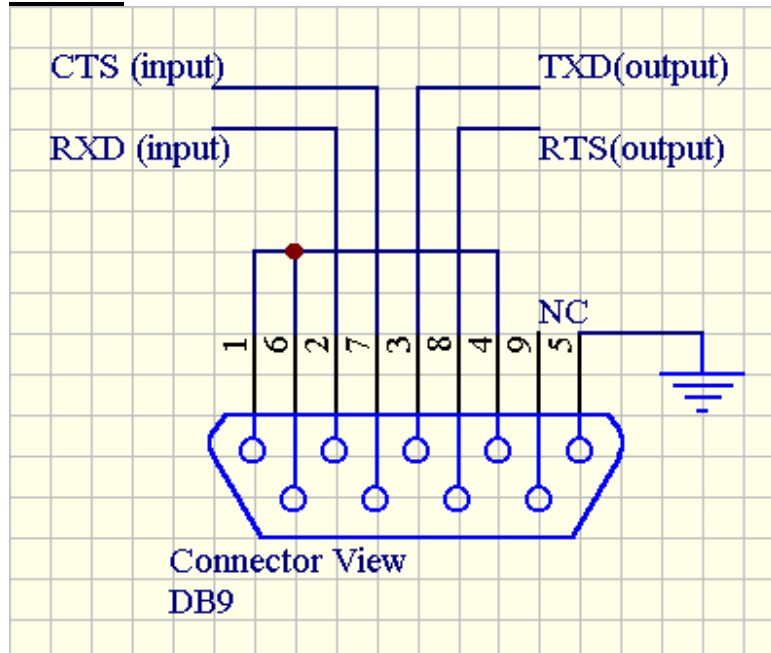

Blue tooth module serial interface:

Electrical: RS232 compatible

Transmission speeds:

DTE: 300 – 230400 bit/s (asynchronous)

Character representation: 8Bit, no Parity,
or 7Bit even/odd Parity

1 or 2 stop bits

Character synchronization: asynchronous

Operating mode: half duplex or full duplex

Flow control Hardware (RTS/CTS)

Bluetooth link: RF part: 0 dBm Radio,
About 10 m (Bluetooth Power Class 2)

Bluetooth Spec: 1.1

Flow control credit based

Bluetooth antenna: internal



Physical dimensions:

casing: 35 x 16 x 65 mm (WxHxD)

Plastic ABS

Operating Temperature: -40 to 85 °C

Storage Temperature: -40 to 85 °C

Humidity: 10% to 95% non condensing

Power supply:

External power supply +6V DC to +35VDC.

Idle: ca. 45 mA, active: ca. 50 to 70 mA.

Idle: ca. 22 mA, active: ca. 30 to 50 mA.