



# Installation Manual

For 120X models:  
For 120X-IM models:

12.0 cu.ft., 2-way, 4-door, R.V. refrigerator.  
12.0 cu.ft., 2 way, 4-door, R.V. refrigerator with ice maker.



**WARNING:** Improper installation, adjustment, alteration, service or maintenance can cause injury or property damage. Refer to this manual. For assistance or additional information, contact a qualified installer, service agency, or the gas supplier.

#### FOR YOUR SAFETY

Do not store or use gasoline or other flammable vapors and liquid in the vicinity of this or any other appliance.

#### FOR YOUR SAFETY

If you smell gas:

1. Open windows.
2. Don't touch electrical switches.
3. Extinguish any open flame.
4. Immediately call your gas supplier.



**WARNING:** DO NOT install this refrigerator in below deck marine applications. Do not install this refrigerator in a fixed indoor cabin or other dwelling applications. This refrigerator must use only NORCOLD designed and approved outside air intake and exhaust ventilation for correct and safe operation. Any other ventilation could cause lethal combustion exhaust fumes and/or explosive propane gas fumes to be in the living area and/or to be below deck.

English

French

NORCOLD, Inc.  
P.O. Box 4248  
Sidney, OH 45365-4248

## Table of Contents

---

Safety Awareness .....	2
Safety Instructions .....	2
Certification and Code Requirements .....	2
Ventilation Requirements .....	3
Assemble the Enclosure for the Refrigerator .....	3
Install the Lower and Upper Vents .....	4
Install Decorative Door Panels .....	6
Install the Refrigerator .....	6
Optional Installation .....	6
Connect the Ice Maker (optional) .....	7
Connect the water supply line .....	7
Connect the Electrical Components .....	7
Connect the 120 volts AC supply .....	7
Connect the 12 volts DC supply .....	7
Connect the Propane Gas Components .....	8
Connect the propane gas supply system .....	8
Examine the propane gas supply system for leaks .....	8
Ignition and Start Up .....	9
Ignition and start up in automatic mode .....	9
Ignition and start up in manual mode .....	9
Do a test of the gas safety valve .....	9
Shut down .....	9
Fault Codes .....	10

## Safety Awareness

---

Read this manual carefully and understand the contents before you install the refrigerator.

Be aware of possible safety hazards when you see the safety alert symbol on the refrigerator and in this manual. A signal word follows the safety alert symbol and identifies the danger of the hazard. Carefully read the descriptions of these signal words to fully know their meanings. They are for your safety.

 **WARNING:** This signal word means a hazard, which if ignored, can cause dangerous personal injury, death, or much property damage.

 **CAUTION:** This signal word means a hazard, which if ignored, can cause small personal injury or much property damage.

## Safety Instructions

---

 **WARNING:**

- This refrigerator is not approved for use as a free standing refrigerator. It is equipped for the use of propane gas only and can not be changed to use any other fuels (natural gas, butane, etc.).

- Incorrect installation, adjustment, alteration, or maintenance of this refrigerator can cause personal injury, property damage, or both.
- Obey the instructions in this manual to install intake and exhaust vents.
- Do not install the refrigerator directly on carpet. Put the refrigerator on a metal or wood panel that extends the full width and depth of the refrigerator.
- Propane gas can ignite and cause an explosion that can result in property damage, personal injury, or death. Do not smoke or create sparks. Do not use an open flame to examine the propane gas supply line for leaks. Always use two wrenches to tighten or loosen the propane gas supply line connections.
- Make sure the electrical installation obeys all applicable codes. See "Certification and Code Requirements" section.
- Do not bypass or change the refrigerator's electrical components or features.
- Do not spray liquids near electrical outlets, connections, or the refrigerator components. Many liquids are electrically conductive and can cause a shock hazard, electrical shorts, and in some cases fire.
- The refrigerator cooling system is under pressure. Do not try to repair or to recharge a defective cooling system.
- The cooling system contains sodium chromate. The breathing of certain chromium compounds can cause cancer. The cooling system contents can cause severe skin and eye burns, and can ignite and burn with an intense flame. Do not bend, drop, weld, move, drill, puncture, or hit the cooling system.

 **CAUTION:**

- The rear of the refrigerator has sharp edges and corners. To prevent cuts or abrasions when working on the refrigerator, use caution and wear cut resistant gloves.

## Certification and Code Requirements

---



Art01290

This refrigerator is certified by CSA International as meeting the latest edition of ANSI Z21.19 and CAN 1.4 standards for installation in mobile homes or recreational vehicles.

The installation must obey these standards and this "Installation Manual" for the NORCOLD limited warranty to be in effect. Installation must conform with local codes. In the absence of local codes, the installation must obey these standards:

**In the United States:**

- National Fuel Gas Code, ANSI Z223.1.
- Manufactured Home Construction and Safety Standard, Title 24 CFR, Part 32-80.
- Standard for Recreational Vehicles, RVIA A119.2 latest edition.
- For installations which need an electric outlet that is energized by an external power source, the refrigerator must be electrically grounded as written in local or state codes, the National Electrical code, and ANSI/NFPA 70.

**In Canada:**

- Current CGA B149.1 and CGA B149.2 Installation code for Propane Appliances and Equipment.
- Current CSA Z240.4.2 Installation Requirement for Propane Appliances and Equipment in Recreational Vehicles.
- Current CSA Z240.6.2/C22.2 No. 148 Electrical Requirement for Recreational Vehicles.
- When installed, the refrigerator must be electrically grounded in accord with local or state codes, the Canadian Electrical Code C22.2. Parts 1 and 2.

All propane gas supply piping and fittings must obey local, state, and national codes about type and size. These components must also obey the current NFPA 501C section 2-4, and in Canada with the current CAN 1-6.10 Standard.

Certified installation needs one lower intake vent and one upper exhaust vent. Install the vents exactly as written in this manual. Any other installation method voids both the certification and the factory warranty of the refrigerator.

The bottom of the opening for the lower intake vent, which is also the service access door, must be even with or immediately below the floor level. This allows any leaking propane gas to escape to the outside and not to collect at floor level.

CSA International certification allows the refrigerator to have zero (0) inch minimum clearance at the sides, rear, top, and bottom. While there are no maximum clearances specified for certification, the following maximum clearances are necessary for correct refrigerator performance:

Bottom	0 inch min.	0 inch max.
Each Side	0 inch min.	1/2 inch max.
Top	0 inch min.	1/4 inch max.
Rear	0 inch min.	1 inch max.

These clearances plus the lower and upper vents allow the natural air draft that is necessary for good refrigeration. Cooler air comes in through the lower vent, goes up around the refrigerator coils where it removes the excess heat from the refrigerator components, and goes out through the upper vent.

The refrigerator also has two thermostat controlled fans to move air across the cooling system. These fans turn on when the condenser fin temperature at the thermostat is about 130° F or higher and only when the refrigerator controls are on. These fans turn off when the condenser fin temperature at the thermostat is about 115° F or less. Even with these fans, if the air flow is blocked or decreased, the refrigerator will not cool correctly.

Each NORCOLD model is certified by CSA International for correct ventilation. Install only the certified vents that are listed in this manual.

**Ventilation Requirements**



**WARNING:** The completed installation must:

- Make sure there is sufficient intake of fresh air for combustion.
- Make sure the living space is completely isolated from the combustion system of the refrigerator.
- Make sure there is complete and unrestricted ventilation of the flue exhaust which, in gas mode, can produce carbon monoxide. The breathing of carbon monoxide fumes can cause dizziness, nausea, or in extreme cases, death.
- Make sure the refrigerator is completely isolated from its heat generating components through the correct use of baffles and panel construction.

**Assemble the Enclosure for the Refrigerator**

1. Make sure the enclosure is 63 1/4 inches high x 32 11/16 inches wide x 24 inches deep.
2. Make sure the floor is solid and level:
  - The floor must be metal or a wood panel and extend the full width and depth of the enclosure.
  - The floor must be able to support the weight of the refrigerator and its contents.
3. Make sure there are no adjacent heat sources such as a furnace vent, a hot water heater vent, etc.

## Install the Lower and Upper Vents

1. Using the following chart, decide which vents and rough opening (RO) sizes to use:

Certified Vent	P/N	RO Height	RO Width
Upper Roof Exhaust Cap	622293	N/A	N/A
Upper Roof Exhaust Vent	616319	24 in.	5 1/4 in.
Lower Square Corner Intake	616010	9 3/4 in.	19 3/8 in.
Upper Exhaust & Lower Intake Plastic	621156	13 3/4 in.	21 1/2 in.

2. Install the lower intake vent:

NOTE: The lower intake vent is also the service access opening for the components on the rear of the refrigerator.

 **WARNING:** Make sure the bottom of the opening of the lower intake vent is even with or immediately below the floor level. This allows any leaking propane gas to escape to the outside and not to collect at floor level.

- Make sure the bottom of the opening of the lower intake vent [1] is even with or immediately below the floor level (See Art01597).
- Make sure that the opening for the lower intake vent is between 1/2 inch and 1 inch from the burner side of the refrigerator enclosure.

3. Install the upper exhaust vent:

 **CAUTION:** Make sure that no sawdust, insulation, or other construction debris is on the refrigerator or in the enclosure. Debris can cause a combustion hazard and prevent the refrigerator from operating correctly.

NOTE: Tighten the screws of the upper roof exhaust cap to 10 inch-pounds max. Also make sure that the air flow around the upper roof exhaust cap is not blocked or decreased by other roof mounted features such as a luggage carrier, an air conditioner, a solar panel, etc.

- If the design of the vehicle allows, install the roof exhaust vent [2] directly above the lower intake vent [1] (See Art01597 and Art01596).
- Install a baffle [4] to prevent stagnant hot air in the area [5] above the refrigerator.

- Make sure there is less than 1/4 inch clearance [6] between the baffle and the top of the refrigerator.

- Make sure the baffle is the full width of the inside of the enclosure.

- If the design of the vehicle does not allow you to install the roof exhaust vent directly above the condenser of the refrigerator:

- Align the roof exhaust vent [2] above the lower intake vent and move it inboard as necessary (See Art01597 and Art01595).

- Install two baffles [7] to prevent stagnant hot air in the area [5] above the refrigerator.

- Make sure the baffles are the full width of the inside of the enclosure.

- Make sure that the baffles are no more than 45° from vertical [8].

- Put one baffle between the top rear edge of the refrigerator and the inside edge of the roof exhaust vent opening.

- Put the other baffle between the outside edge of the roof exhaust vent opening and the side wall of the vehicle.

- If the depth of the enclosure is 24 inches or more and is less than 25 inches, no baffles are necessary at the rear of the enclosure.

- If the depth of the enclosure is 25 inches or more and is less than 26 inches, add two baffles [9] to the rear of the enclosure (See Art01595 and Art01596).

- Put one baffle 18 inches to 18 1/2 inches above the bottom of the enclosure [25] (4 1/4 inches to 4 3/4 inches above the top of the lower intake vent opening REF) [26].

- Put the other baffle at the lowest edge of the condenser [3] of the refrigerator.

- Make sure that the baffles are 1 inch or less [27] from the coils [2] and condenser of the refrigerator.

- Make sure that the baffles are the full width of the inside of the enclosure.

- If the depth of the enclosure is more than 26 inches, install a wood or an aluminum or galvanized sheet solid box baffle [28] in the rear of the enclosure (See Art01644 and Art01645).

- Make sure that the bottom of the solid box baffle is 18 inches to 18 1/2 inches above the bottom of the enclosure [25] (4 1/4 inches to 4 3/4 inches above the top of the lower intake vent opening REF) [26] .
  - Make sure that the back of the solid box baffle is perpendicular to the bottom of the enclosure.
  - Make sure that the back of the solid box baffle is either against the top of the enclosure or against the angled baffle [7] (depending on the vehicle design).
    - Make sure that the solid box baffle is one inch or less [29] from the coils [2] and condenser of the refrigerator.
    - Make sure that the solid box baffle is the full width of the inside of the enclosure.
  - If there is more than 1/2 inch of clearance between either side of the refrigerator and the wall, fill the space with fiberglass insulation or add a baffle to eliminate the excess clearance.
  - If the design of the vehicle does not allow you to install a roof exhaust vent, install an upper side-wall exhaust vent.
- NOTE: The refrigerator is 23.7 in. min. to 24.0 in. max. from the rear of the breaker to the rear of the condenser [10] and is 59.0 in. min. to 59.3 in. max. from the bottom of the refrigerator to the bottom of the refrigerator condenser [11] (See Art01600).
- Install the upper side-wall exhaust vent [12] so that the distance [13] from the bottom of the enclosure to the top of the rough opening for the upper exhaust vent is at least 63 inches (see Art01588 and Art01589).
    - Align the upper exhaust vent horizontally above the lower intake vent [1].
    - To prevent stagnant hot air in the area above the refrigerator, install an aluminum or galvanized steel sheet baffle [14] between the top of the refrigerator and the top of the upper exhaust vent,
      - Make sure there is 1/4 inch or less of clearance between the baffle and the top of the refrigerator and that the baffle overlaps the refrigerator 1 inch or less [15].
      - Make sure that the baffle is against the wall of the vehicle at the top of the upper exhaust vent and 1/4 inch or less from the top of the opening for the upper exhaust vent [16].
      - Make sure the baffle is the full width of the inside of the enclosure.
  - Make sure the clearance at the sides of the refrigerator is correct:
    - If there is more than 1/2 inch of clearance between either side of the refrigerator and the wall, fill the space with fiberglass insulation or add a baffle to eliminate the excess clearance.
  - When using an upper side-wall exhaust vent:
    - If the depth of the enclosure is more than 24 inches and less than 26 inches [17], install a bent aluminum or galvanized steel sheet baffle [18] to the rear of the enclosure (See Art01588).
      - Make sure that the bend of the baffle is the full width of the inside of the enclosure.
      - Make sure that the bend of the baffle is flush with the bottom edge of the upper intake vent door frame.
      - Make sure that the top edge of the baffle is 1/4 inch or less [19] below the condenser [20] and that there is 1/4 inch or less clearance [21] between the lower rear corner of the condenser and the baffle.
    - If the depth of the enclosure is more than 26 inches [22], install a wood or an aluminum or galvanized steel sheet solid box baffle [23] between the lower intake vent and the upper exhaust vent (See Art01589).
      - Make sure that the solid box baffle is the full width of the inside of the enclosure.
      - Make sure that the bottom of the solid box baffle is 18 inches to 18 1/2 inches above the bottom of the enclosure [25] (4 1/4 inches to 4 3/4 inches above the top of the lower intake vent opening REF) [26] .
      - Make sure that the back of the solid box baffle is perpendicular to the bottom of the enclosure.
      - Make sure that the horizontal top of the solid box baffle is even with the bottom edge of the upper exhaust vent [12].
      - Make sure that the vertical top edge of the baffle is 1/4 inch or less [19] below the lower rear corner of the condenser [3].
      - Make sure that there is 1/4 inch or less clearance [21] between the rear of the condenser and the baffle.

## Install Decorative Door Panels

---

NOTE: The doors are made to accept decorative panels. The decorative panels must be 3/16 inch or less in thickness. Install the decorative door panels in the refrigerator doors before installing the refrigerator in the vehicle.

1. Make two upper door panels that are 16 13/64 inches wide x 18 3/8 inches high:
  - Raised panels must be centered on each door and no larger than 15 11/32 inches wide x 17 17/32 inches high.
2. Make two lower door panels that are 16 13/64 inches wide x 41 13/64 inches high:
  - Raised panels must be centered on each door and no larger than 15 11/32 inches wide x 40 11/32 inches high.
3. Install the decorative door panels:
  - Pull the panel retainer [1] off of each door [3] (See Art00965).
  - Push a decorative door panel [2] into the slots of each door.
  - Make sure that each panel retainer is correctly positioned and push the curved snap [4] of the panel retainer [5] inside of the curved snap [6] of the door (See Art01590).

- Push the refrigerator completely into the enclosure.
- Put the screws [1] through the upper and then the lower mounting bracket on the front of the refrigerator and into the enclosure wall (See Art01106).
- Put a corner trim piece [3] on each front corner of the refrigerator (See Art01106, Art01584, and Art01585).
  - Make sure that each corner trim piece is behind the side trim [4].
- Put the top and bottom trim pieces [5] against the front of the refrigerator (See Art01106, Art01585, Art01586, and Art01587).
  - Make sure that the top and bottom trim pieces are on top of each of the corner trim piece.
  - Put the edge of the top and bottom trim pieces over the edge of the aluminum extrusion [6].
  - Push the Y-shaped edge of each trim piece over the opposite side of the aluminum extrusion until it locks into position against the vehicle wall [7].
- Put two screws through the holes [4] in the mounting flange on the rear of the refrigerator and into the floor (See Art00996).

## Install the Refrigerator

---

Put the refrigerator in position:

 **WARNING:** Make sure the combustion seal is not broken, is completely around the refrigerator mounting flanges, and is between the mounting flanges and the wall of the enclosure. If the seal is not complete, exhaust fumes can be present in the living area of the vehicle. The breathing of exhaust fumes can cause dizziness, nausea, or in extreme cases, death.

NOTE: Be careful when you put the refrigerator into position. The refrigerator has vacuum insulating panels on the top and sides. If punctured, these panels lose insulation value which decreases the cooling performance of the refrigerator.

- Make sure that the flue cap is not pushed down against the top of the flue tube.

## Optional Installation

---

You can change enclosures that were made for Norcold model N8XX refrigerators so that you can put Norcold model 120X refrigerators into them.

To change the Norcold model N8XX refrigerator enclosure [23] into the Norcold model 120X refrigerator enclosure [24] (See Art01597):

- Increase the height of the enclosure by 3 3/8 inches [25].
- Increase the width of the enclosure by 8 13/16 inches [26].
- Make sure to add the additional width to the left side of the enclosure (as looking at the rear of the refrigerator).

Install the necessary baffles only as written in the "Install the Upper and Lower Vents" section of this manual.

The locations of the 12 VDC supply, the 120 VAC supply, and the propane gas supply line do not change.

## Connect the Ice Maker (optional)

---

The ice maker is assembled to the refrigerators at the factory as optional equipment. If the refrigerator does not have a factory installed ice maker, one can not be added to the refrigerator at a later time.

The refrigerator installer must connect a cold water supply line to the solenoid valve at the rear of the refrigerator. The following are necessary to connect the icemaker:

- 1/4 in. OD copper tubing for the water supply line.

OR

- 1/4 in. OD plastic tubing for the water supply line.
- 1/4 in. shut off valve in the water supply line. This should be easily accessible through the lower intake vent.

### Connect the water supply line:

Install a 1/4 in. OD water supply line [1] from the water shut off valve of the vehicle to the solenoid water valve [2] at the rear of the refrigerator (See Art01014):

NOTE: A brass compression nut [1], a brass sleeve, a plastic sleeve [2], and a brass insert [3] are supplied and attached to the rear of the refrigerator (See Art01604).

- Put the compression nut and then the sleeve onto the water supply line [4].
  - For copper tubing, use the brass sleeve.
  - For plastic tubing, use the plastic sleeve [2].
  - For plastic tubing with .040 in. wall thickness, also use the brass insert [3].
- Flush the water supply line until the water is clear.
- Put the tubing into the adapter [5] until it is against the stop of the adapter.
- Tighten the compression nut by hand (hard finger tight).
- Using two wrenches, tighten the compression nut 1 1/2 to 2 turns.
- Open the water shut off valve of the vehicle.
- Examine the connections for leaks.

## Connect the Electrical Components

---

AC Operation	120 volts AC voltage (132 volts max. - 108 volts min.)
	12 volts DC control voltage (15.4 volts max. - 10.5 volts min.)

This refrigerator operates on these electrical sources. Operation out of these limits may damage the refrigerator's electrical circuit parts and will void the warranty.

### Connect the 120 volts AC supply:



**WARNING:** Connect the AC power cord(s) only to a grounded three-prong receptacle. Do not remove the round ground prong from the AC power cord of the refrigerator or the ice maker (optional). Do not use a two prong adapter or an extension cord with either AC power cord. Operation of the refrigerator without correct ground can cause dangerous electrical shock or death if you are touching the metal parts of the refrigerator.

Put the AC power cord(s) into a grounded three-prong receptacle:

- Make sure the receptacle is positioned within easy reach of the lower intake vent.
- Make sure the power cord(s) does not touch the burner cover, the flue pipe, or any hot component that could damage the insulation of the power cord.

### Connect the 12 volts DC supply:

The refrigerator controls operate on 12 VDC power. As the distance from the vehicle battery to the refrigerator increases, the correct AWG wire size and fuse size also increases. If the wire size is too small for the distance, a voltage drop occurs.

Use a minimum of 18 AWG wire and a maximum 6 Amp fuse. If the wire size is larger than the min. size, use the correct fuse per RVIA A119.2 standard or local codes.

1. Install a fuse in DC power supply wires between the battery and the refrigerator:
  - Put fuse as close to the battery as possible.
2. Connect the DC power supply wires (See Art00966):
  - Attach a 1/4 inch Quick Connect terminal to each DC power supply wire.

NOTE: Do not use the chassis of the refrigerator or the vehicle frame as one of the conductors. Attach the DC power supply wires only to the battery and the power board [1] of the refrigerator.

- Push the positive DC power wire [2] onto the power board terminal that is marked 12VDC.
- Push the DC ground wire [3] onto the power board terminal that is marked GND1 .
- Make sure each DC power supply wire is on the correct polarity terminal.

## Connect the Propane Gas Components

---

### Propane Gas Operation

Propane gas  
(11 inches water column pressure)  
12 volts DC control voltage  
(10.5 volts min. - 15.4 volts max.).

This refrigerator operates on these energy sources. Operation out of these limits can damage the refrigerator electrical circuit parts and will void the warranty

### Connect the propane gas supply system:



**WARNING:** Be very careful when working on or near the propane gas system.

- Do not smoke, or use an open flame near the propane gas system.
- Do not use an open flame to examine for leaks.
- Do not connect the refrigerator to the propane gas tank without a pressure regulator between them.
- To avoid a propane gas leak, always use two wrenches to tighten or loosen the propane gas supply line connections.
- Leaking propane gas can ignite or explode and result in dangerous personal injury or death.

Connect the gas supply line to the refrigerator:

- Make sure that all tubing and fittings obey all local, state, and national codes about size and type.
- Make sure that all flexible metal connectors obey the current CAN1-6.10 Standard.
- Use 3/8" diameter copper tubing as the propane gas supply line and use a 3/8" SAE (UNF5/8 -18) male flare fitting as the connection to the refrigerator.
- Put the propane gas supply line up through the floor of the enclosure.
- Make sure the hole through the floor is large enough allow clearance for the gas supply line.
- Put a weather resistant seal (grommet, sealant, etc.) around the gas supply line where it goes through the floor to prevent vibration and abrasion.
- To prevent vibration and abrasion, make sure that the gas supply line is not against anything in the enclosure.
- Attach the gas supply line to the bulkhead fitting of the refrigerator.

### Examine the propane gas supply line for leaks:



**WARNING:** Do not allow the leak detecting solution to touch the electrical components. Many liquids are electrically conductive and can cause electrical shorts and in some cases, fire.

Use a leak detecting solution to examine the gas supply line and all propane gas connections for leaks.

If you use compressed air for the test:

- The pressure of the compressed air at the manual shut off valve of the refrigerator must not be more than 1/2 psig (14 inches Water Column).
- If the pressure of the compressed air is more than 1/2 psig (14 inches Water Column), remove the gas supply line from the bulkhead fitting of the refrigerator before the test.
- If the pressure of the compressed air is equal to or less than 1/2 psig (14 inches Water Column), close the manual shut off valve of the refrigerator before the test.



## Ignition and Start Up

---

Before ignition or start up of the refrigerator:

- Make sure the air flow in the lower intake vent, through the refrigerator coils and condenser, and out the upper exhaust vent is not blocked or decreased.
- Make sure there are no combustible materials in or around the refrigerator.

**NOTE:** If the gas does not ignite in 30 seconds, the gas safety valve of the refrigerator automatically closes and the controls either select a different energy source and “no” “FL” appears in the center display or the controls change to Stand By Mode (See Art01333).

In Stand By Mode, an audible alarm starts and the code “no” “FL” appears in the center display. This means that the gas did not ignite.

If the gas does not ignite after several attempts, refer to the “Fault Codes” section of this manual.

### Ignition and start up in Automatic Mode:

1. Push the ON/OFF button [1] to start the refrigerator.
2. Push the MODE button [2] until “AU” appears in center display [4].
3. Push the SET TEMP button [3] as needed to set the thermostat at “4-6” temperature setting.
  - If “AU” “AC” appears in the center display, it means that:
    - 120 volt AC power is available to the refrigerator.
    - The refrigerator is operating on AC electric power.
    - After ten seconds, the “AU” “AC” goes off and only a green dot “.” remains to show that the refrigerator is operating.
  - If “AU” “LP” appears in the center display, it means that:
    - 120 volt AC power is not available to the refrigerator.
    - The refrigerator is operating on propane gas.
    - After ten seconds, the “AU” “LP” goes off and only a green dot “.” remains to show that the refrigerator is operating.

### Ignition and start up in Manual Mode:

1. Push the ON/OFF button [1] to start the refrigerator.
2. Push the MODE button [2] until “LP” shows in the center display [4].
3. Push the SET TEMP button [3] to set the thermostat at “4-6” temperature setting.
4. The “LP” remains until you select a different operating mode or shut down the refrigerator.

### Do a test of the gas safety valve:

1. Start up the refrigerator in the manual mode operation.
2. Open the lower intake vent.
3. Remove one wire from the solenoid of the gas safety valve at the rear of the refrigerator.
4. Within 30 seconds, the flame should extinguish. This means that the gas safety valve is operating correctly.
5. Put the wire back on the solenoid of the gas safety valve.
6. Close the lower intake vent.

### Shut down - all models:

To shut down the refrigerator, push and hold the ON/OFF button for two seconds.

## Fault Codes

Fault Codes	Fault Code Meaning	Corrective Actions
No display.	DC voltage is unavailable to the refrigerator control panel or the refrigerator is OFF.	Check: <ul style="list-style-type: none"> <li>- That the refrigerator is ON.</li> <li>- That the battery charging equipment of the vehicle is operational.</li> <li>- That the AC/DC converter is operational (if applicable).</li> <li>- That the DC connection to the refrigerator is not loose.</li> <li>- That the DC fuse of the refrigerator is intact.</li> <li>- See your dealer or a Norcold authorized service center.</li> </ul>
" dr " Audible alarm also.	The door was open for more than 2minutes.	Close the door.
" no " " FL " Audible alarm also.	The burner did not ignite or re-ignite.	Check: <ul style="list-style-type: none"> <li>- That the DC voltage is correct.</li> <li>- That the valve of the propane gas tank(s) is open.</li> <li>- That the propane gas is at the correct pressure.</li> <li>- That the manual shut off valve of the refrigerator is open.</li> <li>- That the propane gas supply line is purged. See "Ignition of propane gas in either auto or manual mode" section of this manual.</li> <li>- See your dealer or authorized Norcold Service Center.</li> </ul>
" no " " AC " Audible alarm also.	AC voltage is unavailable to the refrigerator control.	Check: <ul style="list-style-type: none"> <li>- That the refrigerator plugged in.</li> <li>- That the fuse or circuit breaker of the vehicle is intact.</li> <li>- That the vehicle generator is operational (if applicable).</li> <li>- That the AC fuse of the refrigerator is intact.</li> <li>- See your dealer or authorized Norcold Service Center.</li> </ul>
" AC " " LO "	AC voltage to the refrigerator control panel is too low.	Check: <ul style="list-style-type: none"> <li>- That the AC voltage to the refrigerator is correct.</li> <li>- That the vehicle generator is operational (if applicable).</li> <li>- See your dealer or authorized Norcold Service Center.</li> </ul>
" dc " " LO "	DC voltage to the refrigerator control panel is too low.	Check: <ul style="list-style-type: none"> <li>- That the battery charging equipment of the vehicle is operational.</li> <li>- That the AC/DC converter is operational (if applicable).</li> <li>- That the DC connection to the refrigerator is not loose.</li> <li>- See your dealer or authorized Norcold Service Center.</li> </ul>
Temperature number flashes when SET TEMP button is pushed.	The refrigerator is operating on the "Back Up Operating System".	This is not owner servicable. See your dealer or authorized Norcold Service Center.
" AC " " rE " Audible alarm also.	This is a fault within the refrigerator controls.	This is not owner servicable. See your dealer or authorized Norcold Service Center.
" AC " " HE " Audible alarm also.	This is a fault within the refrigerator controls.	This is not owner servicable. See your dealer or authorized Norcold Service Center.
" Sr " Audible alarm also.	This is a fault within the refrigerator controls.	This is not owner servicable. See your dealer or authorized Norcold Service Center.

Art01501

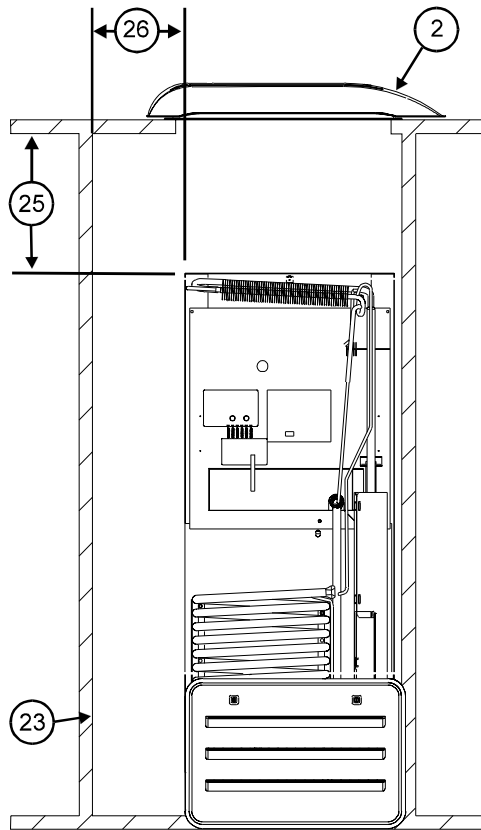

N8XX

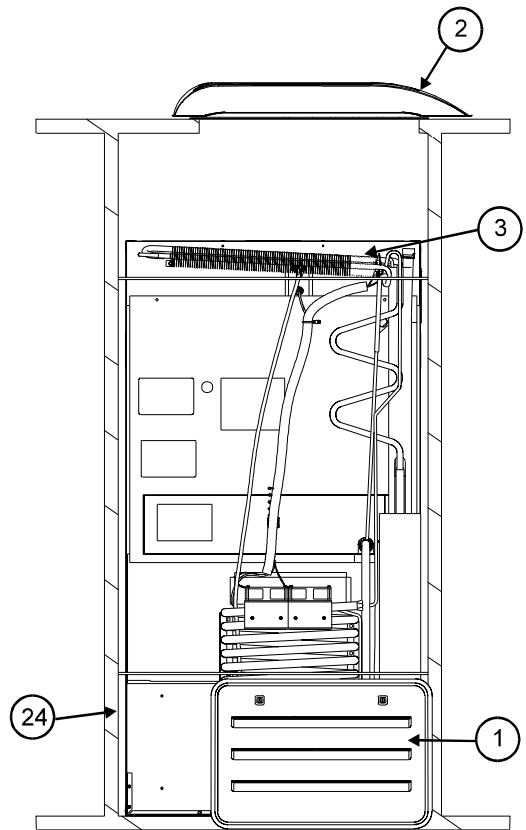

120X

Art01597

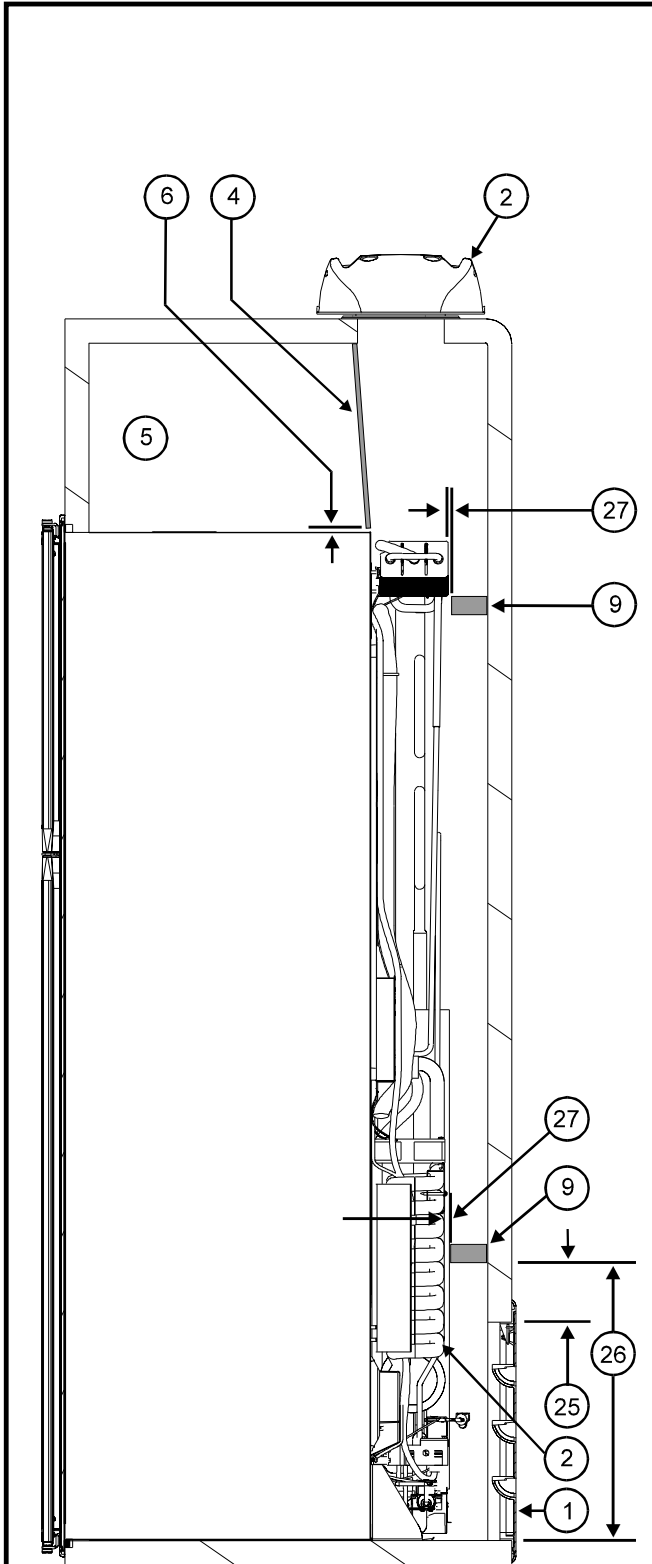

Art01596

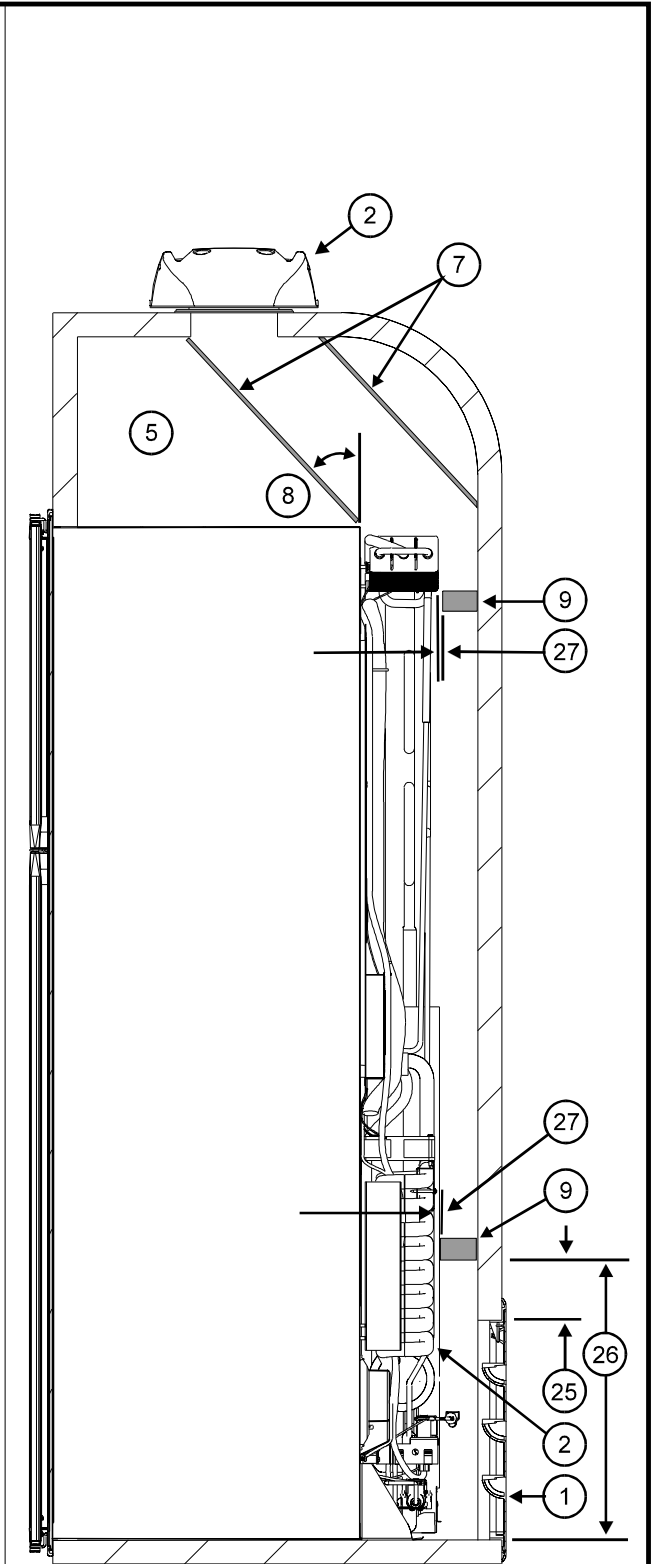

Art01595

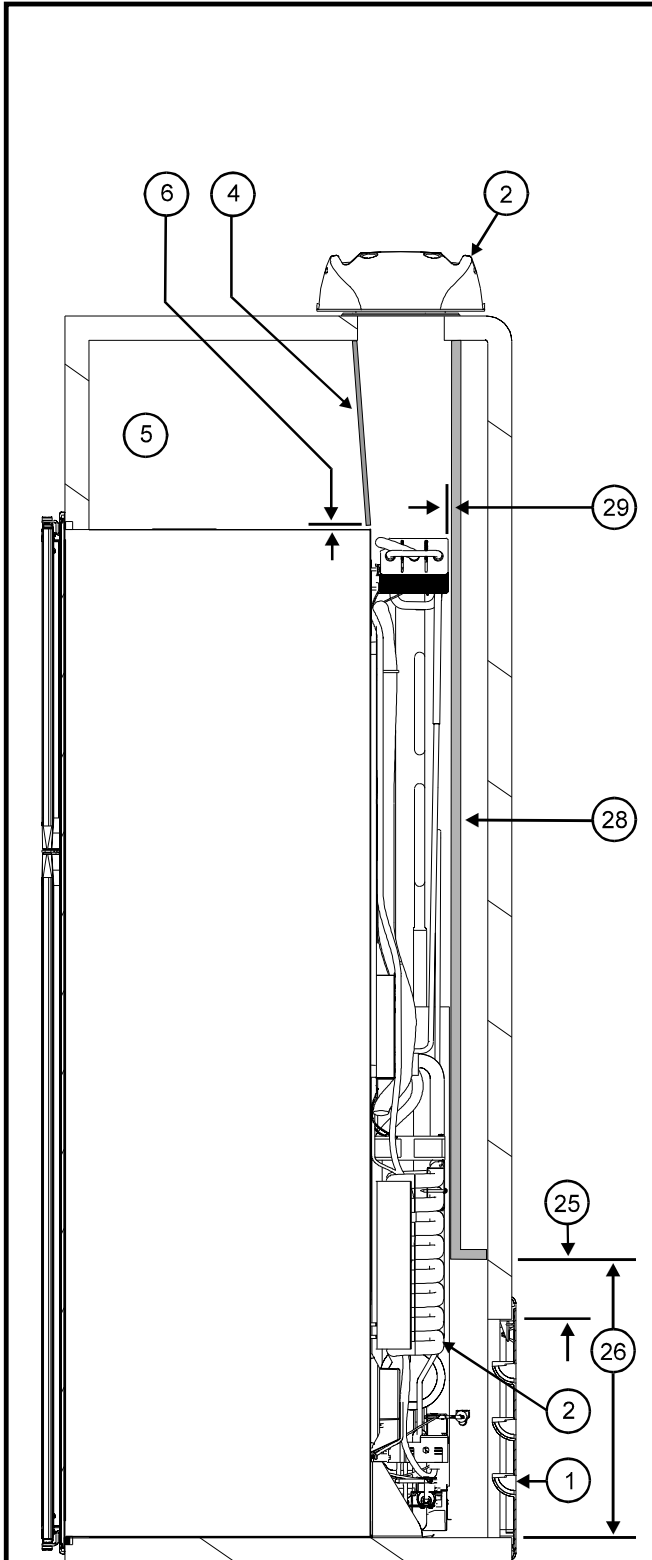

Art01644

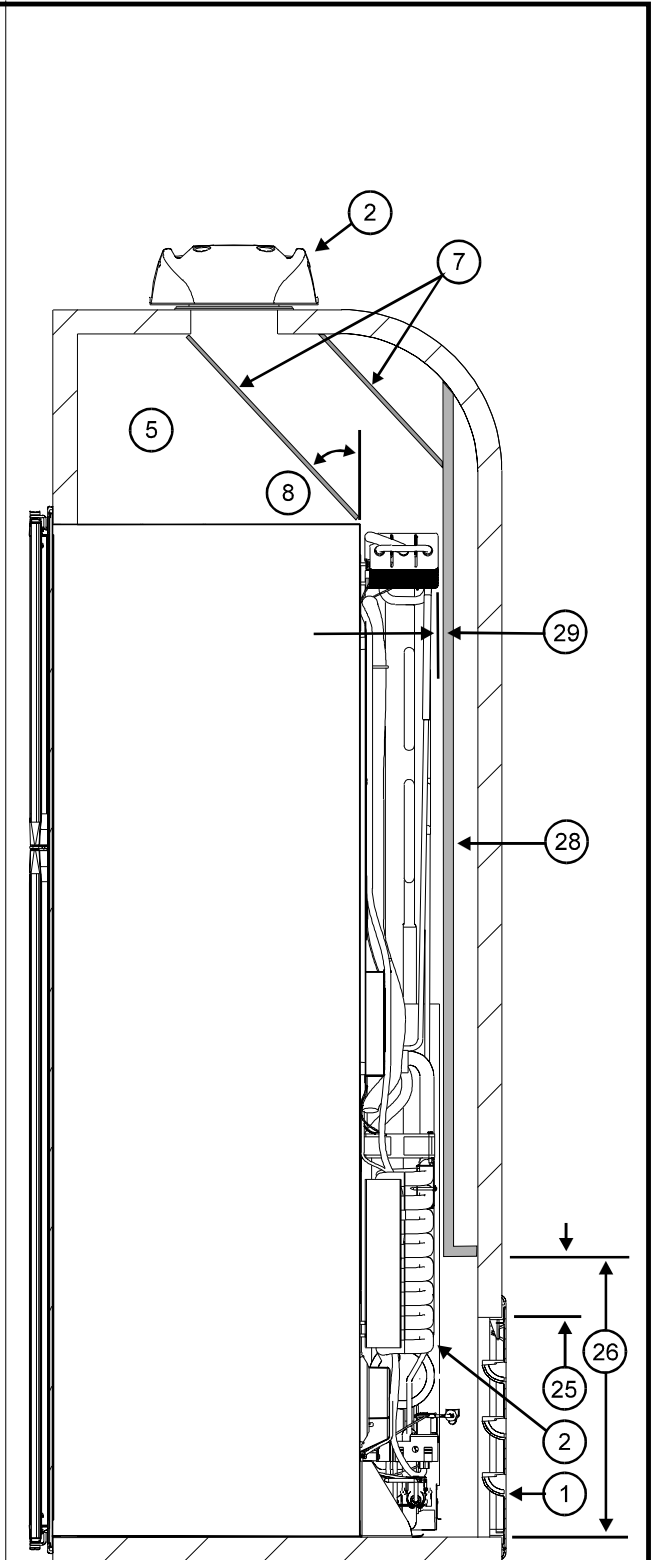

Art01645

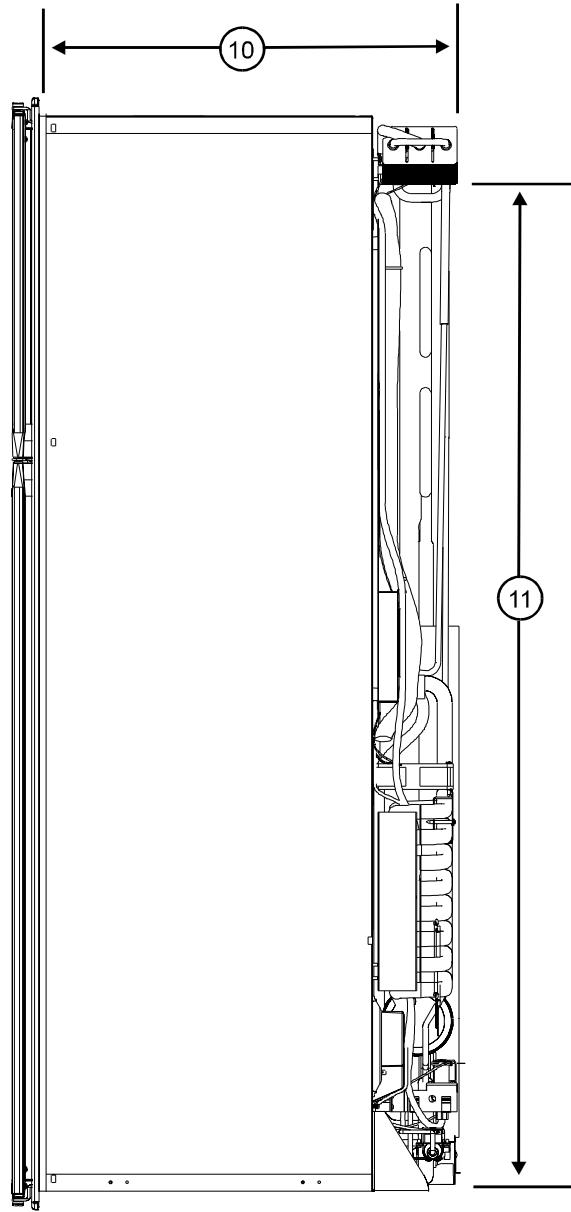

Art01600

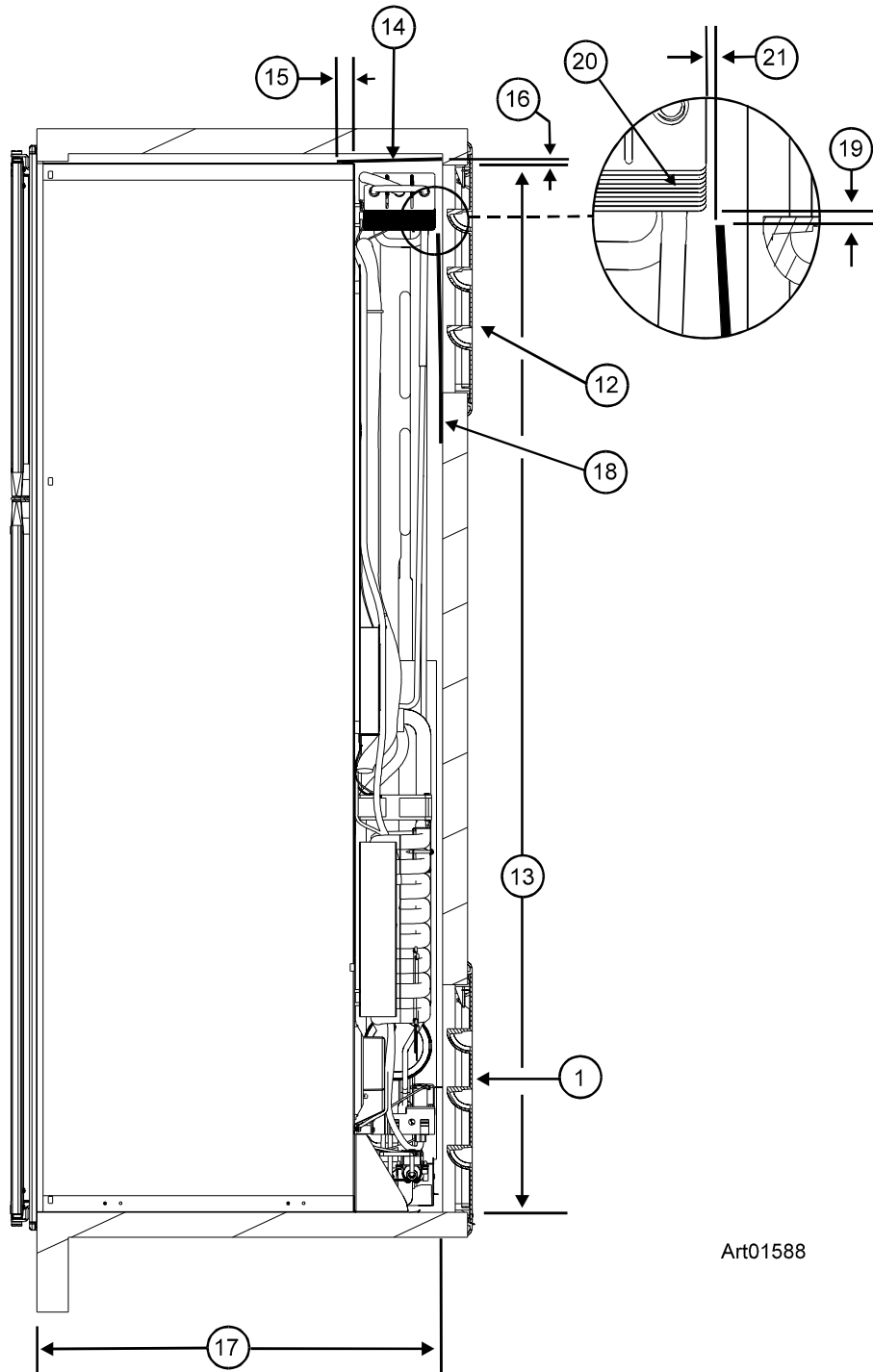

Art01588

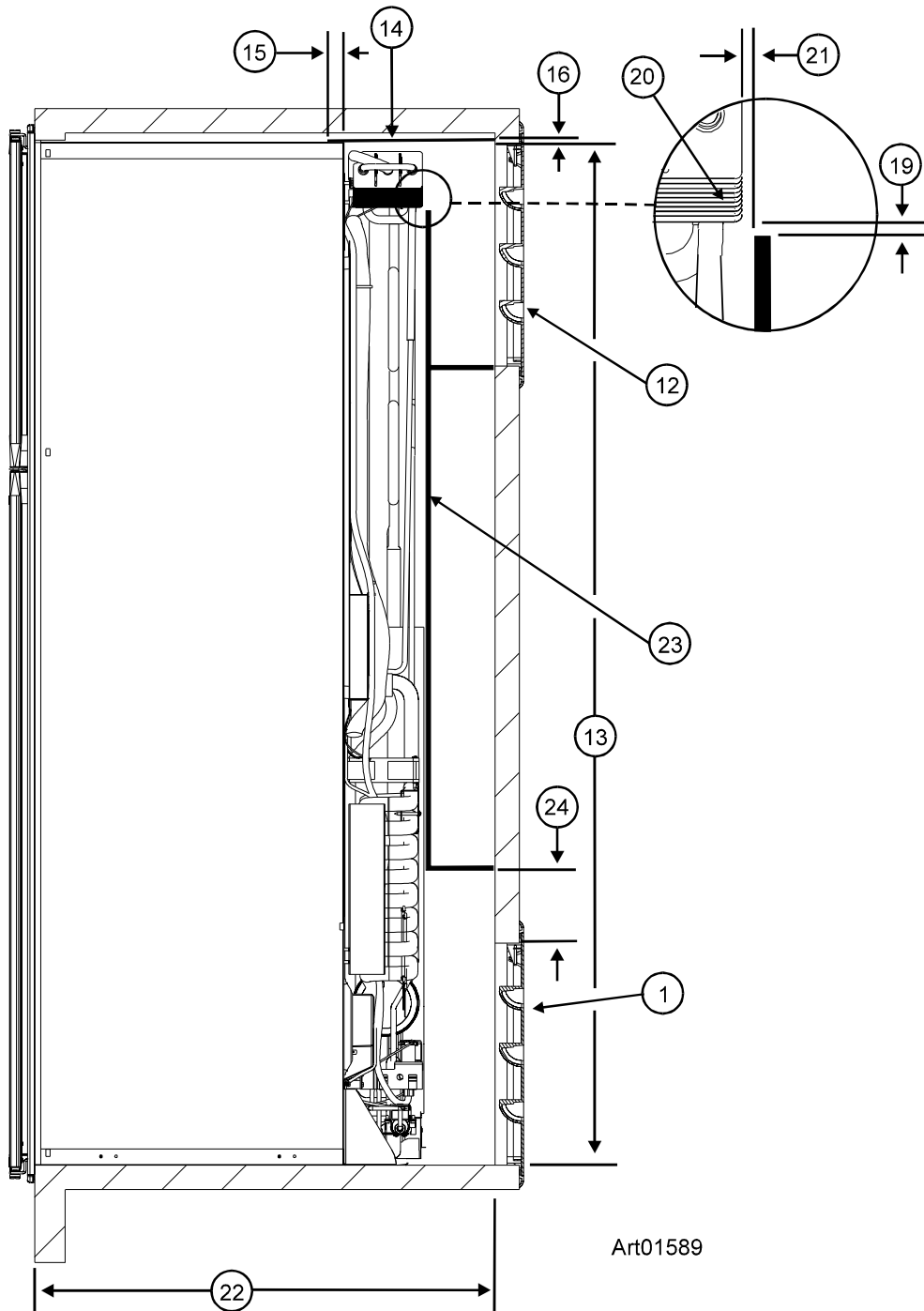

Art01589



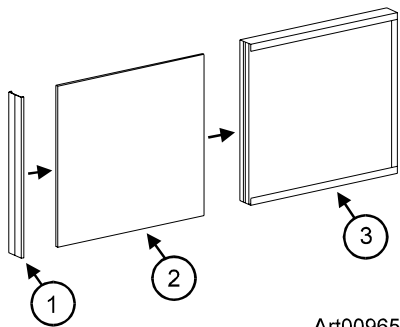

Art00965

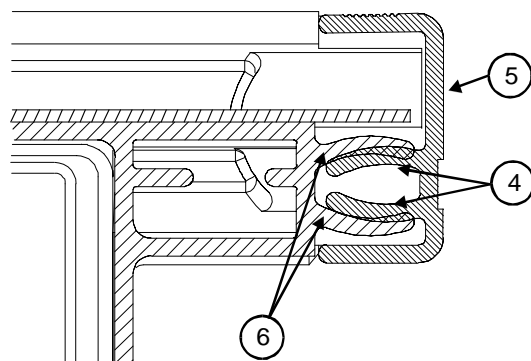

Art01590

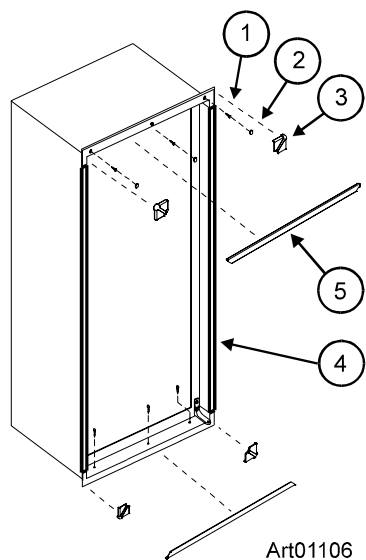

Art01106

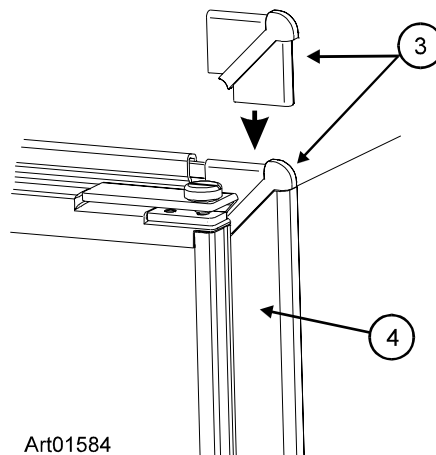

Art01584

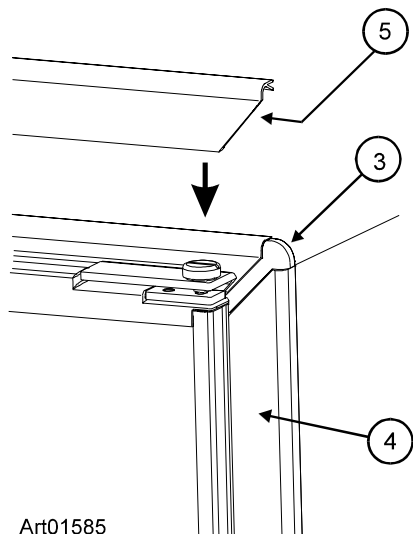

Art01585

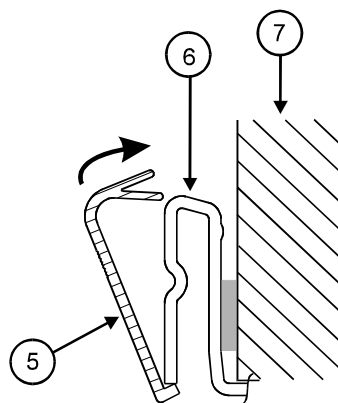

Art01586

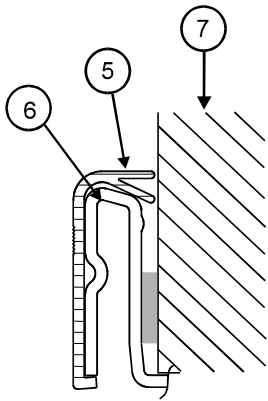

Art01587

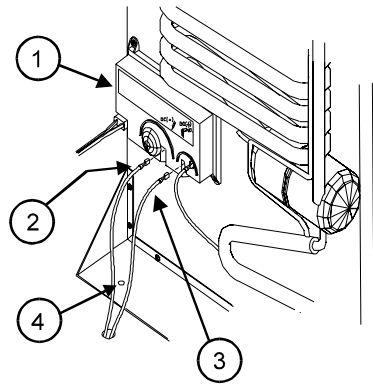

Art00966

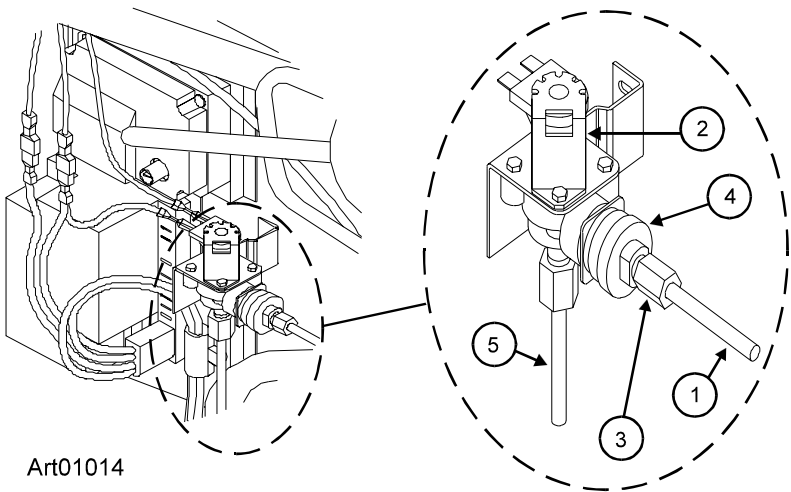

Art01014

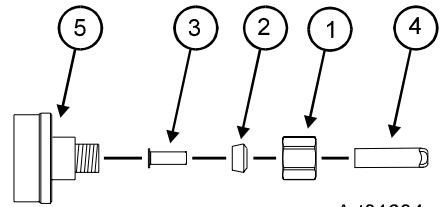

Art01604

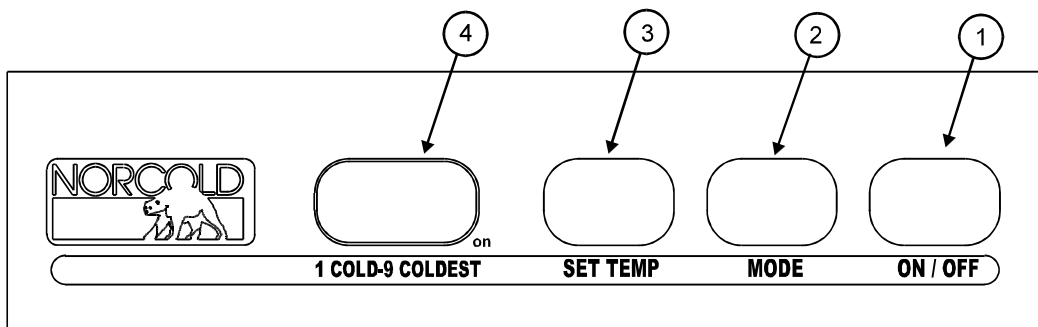

Art01333