



eldes

ELAN3-SNMP

SNMP ETHERNET CONTROLLER

SAFETY INSTRUCTIONS

Please read and follow these safety guidelines to safeguard yourself and others:

- **DO NOT** use the device where it can cause potential danger and interfere with other devices - such as medical devices.
- **DO NOT** use the device in hazardous environment.
- **DO NOT** expose the device to high humidity, chemical environment or mechanical impact.
- **DO NOT** attempt to repair the device yourself - any repairs must be carried out by fully qualified personnel only.



Please, use the 10-24V 50Hz ~ 210mA AC or 10-24V \square 210mA DC power supply unit that meets the EN 60950-1 standard. Any additional device you connect to the device, such as a computer, must also be powered by an EN 60950-1 approved supply. When connecting the power supply to the device, switching the polarity terminal places does not have any affect.



External power supply can be connected to AC mains only inside installation room with automatic 2-pole circuit breaker capable of disconnecting circuit in the event of short circuit or over-current condition. Open circuit breaker must have a gap between connections of more than 3mm and the disconnection current 5A.

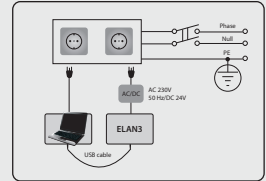

Disconnect the mains power before installing. Never install or carry out maintenance during stormy weather. The electric socket that powers the device must be easily accessible.



To switch the device off, unplug the external electric power supply or any other linked device that the device is powered from. A blown fuse cannot be replaced by the user. The replacement fuse has to be of the kind indicated by the manufacturer (Fuse F1 model - miniSMDC 0,5A).



The WEEE (Waste Electrical and Electronic Equipment) symbol on this product (see left) means it must not be disposed of in household waste. To prevent possible harm to human health and/or the environment, you must dispose of this product in an approved and environmentally safe recycling facility. For further information contact your system supplier, or your local waste authority.

Copyright © "ELDES UAB", 2014. All rights reserved

It is strictly forbidden to copy and distribute information in this document or pass to a third party without an advanced written authorization from "ELDES UAB". "ELDES UAB" reserves the right to update or modify this document and/or related products without a warning. Hereby, "ELDES UAB" declares that the SNMP Ethernet Controller ELAN3-SNMP is in compliance with the essential requirements and other relevant provisions of Directive 1999/5/EC. The declaration of conformity may be consulted at www.eldes.it.



CONTENTS

1. GENERAL INFORMATION	5
2. TECHNICAL SPECIFICATIONS	5
2.1. Electrical & Mechanical Characteristics	5
2.2. Main Unit, LED Indicator & Connector Functionality	6
2.3. Wiring Diagrams	7
3. INSTALLATION	8
4. GENERAL OPERATIONAL DESCRIPTION.....	9
5. CONFIGURATION, CONTROL AND MONITORING METHODS	9
5.1. Web Browser	9
The following section is intended for input configuration.....	11
5.2. SNMP Manager.....	14
6. TECHNICAL SUPPORT	17
6.1. Troubleshooting	17
6.2. Restoring Default Parameters	17
6.3. Updating the Firmware via USB Cable	17

Limited Liability

The buyer agrees that the device will reduce the risk of fire, theft, burglary or other danger but that it does not guarantee against the occurrence of such events.

“ELDES UAB” will not take any responsibility for the loss of personal effects, property or revenue whilst using the device. The liability of “ELDES UAB” is limited to the value of the device purchased.

“ELDES UAB” is not affiliated with any mobile/wireless/cellular provider and is therefore not responsible for the quality of such services.

Manufacturer Warranty

The device carries a 24-month manufacturer warranty from “ELDES UAB”.

The warranty begins the day the device is purchased by the user and the receipt must be retained as proof of purchase date. The warranty remains valid only if the device is used as intended, following all guidelines outlined in this manual and in accordance with the operating conditions specified.

The warranty is void if the device has been exposed to mechanical impact, chemicals, high humidity, fluids, corrosive and hazardous environments or force majeure factors.

Dear Customer,

Thank you for choosing to purchase the SNMP Ethernet Controller ELAN3-SNMP. Your thoughtful decision will ensure reliable solution for many years as all ELDES products are manufactured to meet the highest standards.

We are confident that you will be completely satisfied with your product. However, in the unlikely event that you do experience a problem, please contact the dealer from whom you made your purchase.

UAB ELDES

CONTENTS OF PACK

Item..... Quantity

- 1. ELAN3-SNMP.....1
- 2. User manual..... 1

Not included:

- Power supply unit - can be obtained from your local distributor.
- Ethernet cable - can be obtained from your local distributor.
- Temperature sensor - can be obtained from your local distributor.
- miniUSB cable - can be obtained from your local distributor.

1. GENERAL INFORMATION

ELAN3-SNMP is a micro-controller based device used to inform users about the state changes on digital or analog inputs and control up to 2 electrical appliances connected to the open-collector outputs. These functions can be configured via web-browser or SNMP Manager software compatible with SNMP (Simple Network Management Protocol) v1.0.

Examples of using the device:

- Any electrical appliance control: lighting, watering, heating etc.
- Remote reboot of the “frozen” devices, such as computer network or a server.

Main features:

- Supported Ethernet connectivity: 10/100 Mbit.
- Supported SNMP protocol: v1.0
- User name/password-protected web-based remote configuration, monitoring and control.
- 4 inputs and 1 open-collector output or 3 inputs and 2 open-collector outputs.
- Inputs customizable as NC or NO.
- Supported input modes: digital or analog.
- 1-Wire interface for up to 8 temperature sensor connection intended for temperature monitoring in different areas.
- Up to 3 destination IP addresses for trap message delivery.

2. TECHNICAL SPECIFICATIONS

2.1. Electrical & Mechanical Characteristics

Power supply	10-24V 50Hz ~ 210mA max. / 10-24V $\bar{\bar{}}$ 210mA max.
Number of inputs/outputs.....	4 inputs & 1 output or 3 inputs & 2 outputs (configurable)
Input value range	0... 10V; 30V max.
Input internal resistance.....	40 k Ω
Output circuit	Open collector output. Output is pulled to COM when turned ON.
Maximum commuted output values.....	30V 50Hz ~ 200mA / 30 V $\bar{\bar{}}$ 200 mA
Maximum supported number of temperature sensors.....	8
Supported temperature sensor model	Maxim®/Dallas® DS18S20, DS18B20
Enclosure dimensions.....	87x107x29 mm
PCB dimensions.....	63x82x17 mm
Operating temperature range.....	-20...+55 °C
Humidity.....	0-90% RH @ 0... +40 °C (non-condensing)

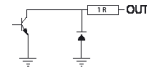

2.2. Main Unit, LED Indicator & Connector Functionality

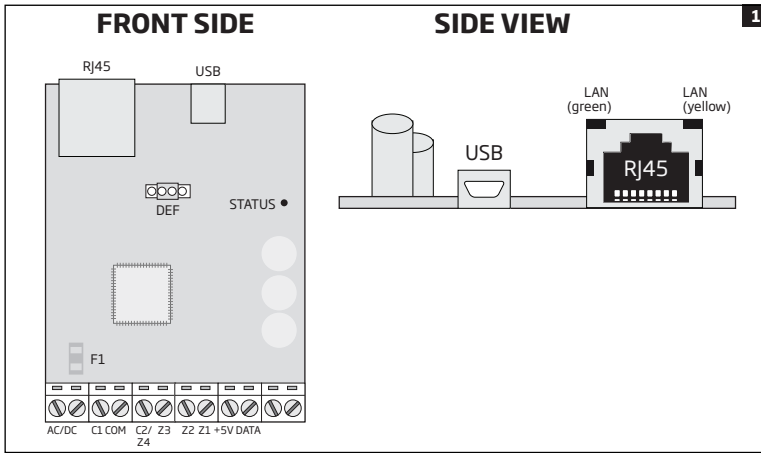

RJ45	10/100Base-T Ethernet port
USB	Mini USB port for firmware update
DEF	Pins for firmware update and restoring default parameters
STATUS	Red light-emitting diode indicating micro-controller status
F1	miniSMDC 0,5A fuse
AC/DC	Power supply terminals
C1	Open-collector output terminal
COM	Common terminal
C2/Z4	Open-collector output digital/analog input terminal
Z3, Z2, Z1	Digital/analog input terminal
+5V	Temperature sensor power supply terminal
DATA	Temperature sensor data terminal
LAN (green)	Green light-emitting diode indicating Ethernet activity
LAN (yellow)	Yellow light-emitting diode indicating Ethernet status

2.3. Wiring Diagrams

General wiring

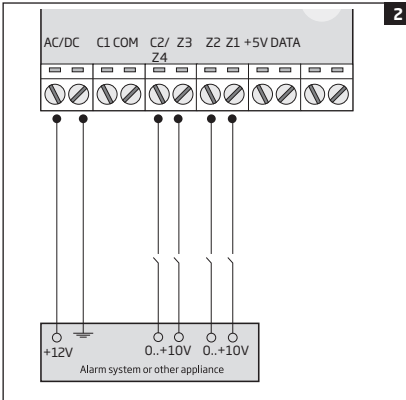

Temperature sensor wiring

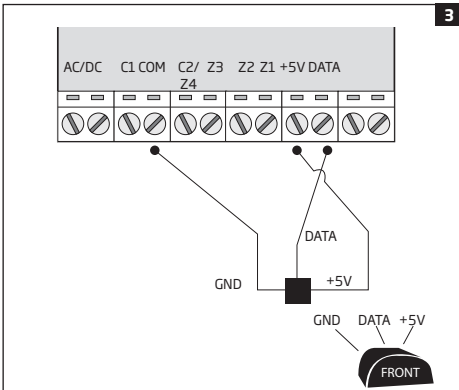

Example of output wiring

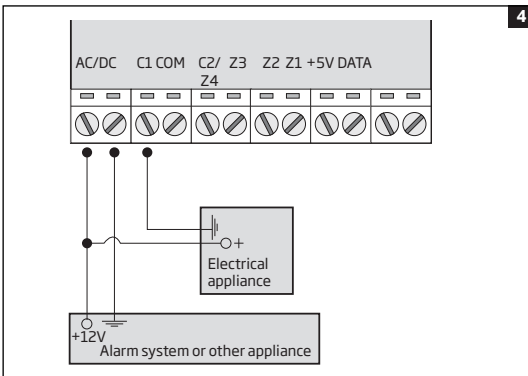

3. INSTALLATION

- The device should be installed indoors, in stationary environment ONLY.
 - For the wiring of input/output terminals, use 0.50 mm² thread unshielded cable of up to 100 meters length.
 - For the wiring of temperature sensor, use 0.50 mm² thread unshielded cable of up to 30 meters length.
1. Mount the device in a designated installation area, such as server room.
 2. Connect **AC/DC** terminals to **10-24V AC or DC** power supply unit (see **2.1. Electrical & Mechanical Characteristics**).
 3. Connect ELAN3-SNMP to local area network router using the Ethernet cable (see Fig. No. 2)

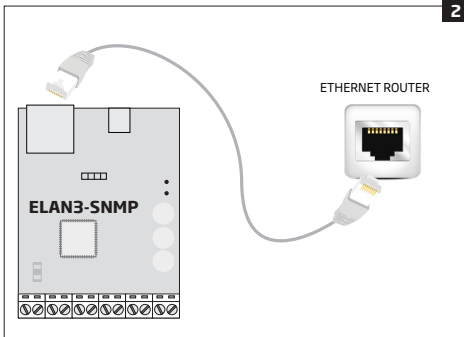

4. Power up ELAN3-SNMP and wait until indicator **STATUS** starts flashing indicating successful micro-controller operation (see Fig. No. 1).
5. Indicator **LAN (green)** will flash indicating Ethernet connection activity, while indicator **LAN (yellow)** will be steady ON indicating successful Ethernet connection (see Fig. No. 1).
6. Once the device is up and running, it will automatically obtain a local IP address from the DHCP server, therefore manual configuration of ELAN3-SNMP is necessary only if DHCP server is not supported by your network.
7. Open a web-browser and type in the following address: <http://eldeselan/>
8. Once prompted to enter the login details, please enter the following:
 - **User name:** 1234
 - **Password:** 1234
9. Proceed to further device configuration, control and monitoring (see **5. CONFIGURATION, CONTROL AND MONITORING METHODS**).
10. If the web-browser fails to open the <http://eldeselan/> address, please proceed as follows:
 - a. Power down ELAN3-SNMP.
 - b. Unplug the Ethernet cable from the RJ45 port of ELAN3-SNMP.
 - c. Power up ELAN3-SNMP and wait for 20 seconds or longer.
 - d. Plug in the Ethernet cable to the RJ45 port of ELAN3-SNMP.
 - e. Open a web-browser and type in the following address: <http://192.168.3.155>
 - f. Log in using the same details as mentioned in item #8.
 - g. Disable DHCP parameter (see **5.1.1. Network**).

4. GENERAL OPERATIONAL DESCRIPTION

ELAN3-SNMP SNMP Ethernet controller uses the Ethernet interface for connection to the Internet and event transmission by trap message to up to 3 preset destination IP addresses.

The device has 4 inputs (customizable as digital or analog) for alarm system's PGM output or detection device connection, such as magnetic door contact. By connecting the device's input to the output of the equipment, you will be able to receive a trap message to the SNMP Manager software regarding equipment status and other events depending on equipment configuration. In addition to being informed by trap message regarding input alarm and restore events as well as input voltage value (mV), the user can control up to two electrical appliances by connecting them to the open-collector outputs. For example, users can turn ON or OFF the heating, lighting, lift the gates, blinds etc.

ELAN3-SNMP can be equipped with up to 8 external temperature sensors for temperature monitoring in different areas.

5. CONFIGURATION, CONTROL AND MONITORING METHODS

5.1. Web Browser

The device comes equipped with remote access feature allowing to configure, control and monitor by logging in to the internal ELAN3-SNMP device's web server, identified as ELAN Configuration Web Server, using any available web-browser.

NOTE: ELAN Configuration Web Server is username/password-protected. By default, the login details are the following: User name: **1234** | password: **1234**

5.1.1. Network

This section is intended for network configuration. In order to avoid the IP address collision in your local area network, once the ELAN3-SNMP device is powered up for the first time it is mandatory to change the default LAN IP Address if DHCP server is not supported by your network.

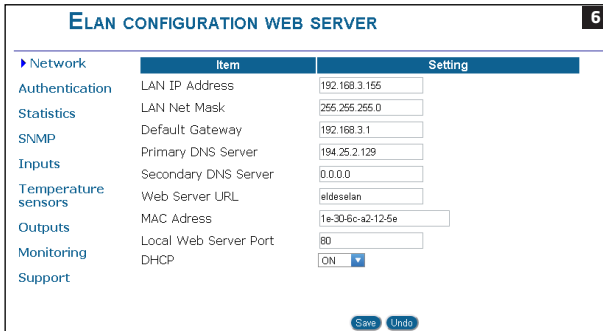

The screenshot shows the 'ELAN CONFIGURATION WEB SERVER' interface with a '6' in the top right corner. A left sidebar lists categories: Network, Authentication, Statistics, SNMP, Inputs, Temperature sensors, Outputs, Monitoring, and Support. The 'Network' category is expanded, showing a table with 'Item' and 'Setting' columns. The settings are: LAN IP Address (192.168.3.155), LAN Net Mask (255.255.255.0), Default Gateway (192.168.3.1), Primary DNS Server (194.25.2.129), Secondary DNS Server (0.0.0.0), Web Server URL (eldesalan), MAC Address (1e-30-6c-a2-12-6e), Local Web Server Port (80), and DHCP (ON). 'Save' and 'Undo' buttons are at the bottom.

Item	Setting
LAN IP Address	192.168.3.155
LAN Net Mask	255.255.255.0
Default Gateway	192.168.3.1
Primary DNS Server	194.25.2.129
Secondary DNS Server	0.0.0.0
Web Server URL	eldesalan
MAC Address	1e-30-6c-a2-12-6e
Local Web Server Port	80
DHCP	ON

LAN IP Address - Local static IP address of the device. Default value is *192.168.3.155*, if DHCP not in use.

LAN Net Mask - Sub-net mask of the device. Default value is *255.255.255.0*, if DHCP not in use.

Default Gateway - Local IP address of gateway. Default value is *192.168.3.1*, if DHCP not in use.

Primary DNS Server - Primary Domain-Name-device server IP address. Default value is *194.25.2.129*, if DHCP not in use. This parameter is mandatory if *Web Server URL* is used.

Secondary DNS Server - Secondary Domain-Name-device server IP address.. Default value is *0.0.0.0*, if DHCP not in use.

Web Server URL - Hostname of the device. Default value is *eldesalan*.

MAC Address - Unique Media-Access-Control address of ELAN3-SNMP device.

Local Web Server Port - Local TCP port of ELAN3-SNMP device. Default value is *80*.

DHCP - Dynamic-Host-Configuration-Protocol:

- **ON** - DHCP enabled. Default parameter.
- **OFF** - DHCP disabled.

Save button - Saves the changes made to the parameters in this page.

Undo button - Cancels the changes made to the parameters in this page.

NOTE: Some networks do not support DHCP. Please, contact your network administrator in order to find out whether DHCP is supported.

5.1.2. Authentication

In this section the user can set up the details required for logging in to ELAN Configuration Web Server.

ELAN CONFIGURATION WEB SERVER**7**

Network	Item	Setting
► Authentication	User name	<input type="text" value="1234"/>
Statistics	Password for user	<input type="password" value="..."/>
SNMP	Retype password	<input type="password" value="..."/>
Inputs		
Temperature sensors		
Outputs		
Monitoring		
Support		

[Change](#) [Undo](#)

User name - User name required for authorization to log in to ELAN Configuration Web Server. Default user name is 1234.

Password for user - Password for authorization to log in to ELAN Configuration Web Server. Default password is 1234.

Retype password - Repeat the password for confirmation when changing it.

5.1.3. Statistics

This section provides the information regarding the established TCP connections.

ELAN CONFIGURATION WEB SERVER**8**

Network	Socket	State	Rem IP	Rem Port	Loc Port	Timer
Authentication	1	CONNECT	192.168.3.150	18905	80	120
	2	LISTEN	-	-	80	-
► Statistics	3	LISTEN	-	-	80	-
SNMP	4	LISTEN	-	-	80	-
	5	LISTEN	-	-	80	-
Inputs	6	LISTEN	-	-	80	-
Temperature sensors	7	CLOSED	-	-	-	-
	8	CLOSED	-	-	-	-
	9	CLOSED	-	-	-	-
Outputs	10	CLOSED	-	-	-	-
Monitoring	11	CLOSED	-	-	-	-
	12	CLOSED	-	-	-	-
Support	13	CLOSED	-	-	-	-
	14	CLOSED	-	-	-	-
	15	CLOSED	-	-	-	-
	16	CLOSED	-	-	-	-

[Refresh](#)

Socket - Sequence number of the socket.

State - Socket state:

- **CONNECT** - Successfully connected to remote IP address.
- **LISTEN** - Ready for connection.
- **CLOSED** - Connection is closed.

Rem IP - Remote IP address the device is connected to.

Rem Port - Remote port number the device is connected through.

Loc Port - Local port number of the device.

Timer - Connection uptime in seconds.

5.1.4. SNMP

This section is intended for SNMP security authorization, device-related information, trap destination IP address and SNMP status (enabled/disabled) configuration.

ELAN CONFIGURATION WEB SERVER		
Network	Item	Setting
Authentication	Read/Write community	public
Statistics	sysDescriptor	Inputs monitoring via SNMP
▶ SNMP	sysContact	ELDES
	sysName	ELAN
Inputs	sysLocation	Vilnius
Temperature sensors	Trap destination1	192.168.1.100
Outputs	Trap destination2	0.0.0.0
	Trap destination3	0.0.0.0
Monitoring	SNMP	OFF
Support		

Save Undo

Get/set Community - Password for authorization to read and write SNMP parameters from/to the device. Default value is *public*.

sysDescriptor - General description of the device. Default value is *Inputs monitoring via SNMP*.

sysContact - The name of person or company whom user can contact if technical support is required. Default value is *ELDES*.

sysName - Several name of device. Default value is *ELAN*.

sysLocation - The name of location where ELAN3-SNMP device is installed. Default value is *Vilnius*.

Trap destination1 - IP address of the 1st trap message destination. Default value is *192.168.1.100*.

Trap destination2 - IP address of the 2nd trap message destination. Default value is *0.0.0.0*.

Trap destination3 - IP address of the 3rd trap message destination. Default value is *0.0.0.0*.

SNMP - Simple-Network-Management-Protocol:

- **OFF** - SNMP enabled. Default parameter.
- **ON** - SNMP disabled.

ATTENTION: In order to send and receive the trap messages to/from the device, SNMP must be selected as ON.

NOTE: The device will accept a trap message from any IP address, if the trap message contains a valid Get/set Community value.

5.1.5. Inputs

The following section is intended for input configuration.

ELAN CONFIGURATION WEB SERVER					
Network	General Settings	Input1	Input2	Input3	Input4
Authentication	Mode	Digital	Digital	Digital	Digital
Statistics	Digital mode Settings	Input1	Input2	Input3	Input4
SNMP	Type	No	No	No	No
▶ Inputs	Threshold	5000 mV	5000 mV	5000 mV	5000 mV
Temperature sensors	Analog mode Settings	Input1	Input2	Input3	Input4
Outputs	Delta	1000 mV	1000 mV	1000 mV	1000 mV
Monitoring	SNMP settings	Input1	Input2	Input3	Input4
Support	Input name	Input1	Input2	Input3	Input4
	State ON name	On1	On2	On3	On4
	State OFF name	Off1	Off2	Off3	Off4
	Priority	1	1	1	1

Save Undo

Mode

- **Digital** - The device measures the input voltage resulting in input state (violated/restored) change in accordance with the Threshold parameter and trap message delivery to the destination IP address (-es) of SNMP Manager software.
- **Analog** - The device measures the input voltage resulting in voltage value inclusion in the trap message. The value will be included in the trap message delivered to the destination IP address (-es) of SNMP Manager software in case of voltage decrease or increase in accordance with the *Delta* parameter.
- **Off** - Input disabled.

Type

- **No** - Sets input type as normally-open. Connecting the circuit leads to input violation. Default parameter.
- **Nc** - Sets input type as normally-closed. Disconnecting the circuit leads to input violation.

Threshold - Sets the voltage value (mV) for Digital input mode. The device considers the input violated/restored once this value is exceeded. Value range is 0... 10000 mV. Default value is 5000 mV.

Delta - Sets the voltage value (mV) for Analog input mode. The device will indicate the voltage once it increases or decreases by this value. Value range is 0... 10000 mV. Default value is 1000 mV.

Input name - Title of the input that will be included in the trap message.

State ON name - Title of the violated input state that will be included in the trap message.

State OFF name - Title of the restored input state that will be included in the trap message.

Priority - Priority level for setting a unique identification number for trap message related with a certain input. Value range is 1... 8.

ATTENTION: In order to receive the trap message regarding the voltage change on the inputs, SNMP must be enabled. For more details on how to enable SNMP, please refer to **5.1.4. SNMP**.

For more details on input wiring, please refer to general wiring diagram provided in **2.3. Wiring Diagrams**.

5.1.6. Temperature Sensors

This section is intended for temperature sensor configuration.

The ELAN3-SNMP device may be equipped with up to 8 temperature sensors intended for temperature measurement in the surrounding areas. This feature allows to monitor the temperature of up to 8 different areas in real-time in ELAN Configuration Web Server's section Monitoring (see **5.1.8. Monitoring**) and receive a trap message to up to 3 trap destination IP addresses (see **5.1.4. SNMP**) when the set temperature thresholds, identified as Min Value and Max Value, are exceeded.

Adding, removing temperature sensors

To add a temperature sensor to the device, proceed as follows:

- a) Power down ELAN3-SNMP.
- b) Wire up the temperature sensor to the 1-Wire interface terminals (see **2.3. Wiring Diagrams**).
- c) If more than one temperature sensor is required, wire another sensor in parallel to the previous one.
- d) Add as many temperature sensors as necessary - wire up one after another in parallel - until the number of 8 sensors is reached.
- e) Power up ELAN3-SNMP.

To view the real-time temperature values measured by each temperature sensor, please refer to section Monitoring (see **5.1.8. Monitoring**).

Temperature trap message

The device supports a trap message, which is automatically delivered to the preset destination IP address (-es) if the minimum (Min Value) (by default, 10 °C) or maximum (Max Value) (by default, 25 °C) temperature threshold of the temperature sensor is exceeded.

Optionally, a name for a temperature sensor can be set that will be included in the trap message when delivered to the destination IP address (-es). This feature allows easier identification of the temperature sensor.

ATTENTION: In order to receive the trap message regarding the voltage change on the inputs, SNMP must be enabled. For more details on how to enable SNMP, please refer to **5.1.4. SNMP**.

NOTE: When multiple temperature sensors are connected, please touch and hold the sensor with your fingers and watch the temperature value change to identify the number of the temperature sensor slot.

ELAN CONFIGURATION WEB SERVER					11
Network	Sensor no.	Name	Min Value	Max Value	
Authentication	1	<input type="text" value="N/A"/>	<input type="text" value="10"/>	<input type="text" value="25"/>	
Statistics	2	<input type="text" value="N/A"/>	<input type="text" value="10"/>	<input type="text" value="25"/>	
SNMP	3	<input type="text" value="N/A"/>	<input type="text" value="10"/>	<input type="text" value="25"/>	
Inputs	4	<input type="text" value="N/A"/>	<input type="text" value="10"/>	<input type="text" value="25"/>	
▶ Temperature sensors	5	<input type="text" value="N/A"/>	<input type="text" value="10"/>	<input type="text" value="25"/>	
	6	<input type="text" value="N/A"/>	<input type="text" value="10"/>	<input type="text" value="25"/>	
Outputs	7	<input type="text" value="N/A"/>	<input type="text" value="10"/>	<input type="text" value="25"/>	
Monitoring	8	<input type="text" value="N/A"/>	<input type="text" value="10"/>	<input type="text" value="25"/>	
Support					

Sensor no. - Sequence number of the temperature sensor.

Name - Temperature sensor name that might be included in temperature trap message.

Min Value - Minimum temperature level threshold resulting in temperature trap message delivery to the preset destination IP address(-es) when exceeded. Value range is -55... 125 °C. Default value is 10 °C.

Max Value - Maximum temperature level threshold resulting in temperature trap message delivery to the preset destination IP address(-es) when exceeded. Value range is -55... 125 °C. Default value is 25 °C.

5.1.7.Outputs

This section is intended for output C1 and C2 control.

The ELAN3-SNMP device comes equipped with 2 open collector outputs C1 and C2 designed for electrical appliance connection. Normally, outputs can be used to open/close garage doors, activate lights, heating, watering and much more. When output turns ON, the ELAN3-SNMP triggers any equipment or relay connected to it (see **2.3. Wiring Diagrams**).

When input Z4 is operating in Digital or Analog mode, output C2 will not be available. In such case C2/Z4 terminal can not be used as open-collector output. In order to use C2/Z4 terminal as open-collector output, disable input Z4. For more details on input configuration, please refer to **5.1.5. Inputs**.

NOTE: Output C2 and input Z4 DO NOT operate simultaneously..

ELAN CONFIGURATION WEB SERVER 12

	Output1	Output2
Network		
Authentication	OFF	OFF
Statistics	Attention! Output2 can only be controlled if Input4 is off	
SNMP		
Inputs		
Temperature sensors		
▶ Outputs		
Monitoring		
Support		

[Save](#) [Undo](#)

The output can be turned ON or OFF by selecting a corresponding output status ON or OFF from the drop down list and clicking the **Save** button afterwards. By default, output C1 and C2 are turned OFF.

5.1.8. Monitoring

In this section the user can monitor the input value and state as well as the temperature sensors. The page is automatically refreshed every 5 seconds.

ELAN CONFIGURATION WEB SERVER							13
Network	Status	1	0	0	0	0	
Authentication	Value	Na	Na	Na	Na	Na	
Statistics	Temp1	Temp2	Temp3	Temp4	Temp5	Temp6	Temp7
SNMP	Value	28 °C	Na	Na	Na	Na	Na
Inputs							
Temperature sensors							
Outputs							
Monitoring							
Support							

[Refresh](#)

Input1... 4:

- **Status** - State of the digital input. Value range: 0 - input restored; 1 - input violated; Na - not available.
- **Value** - Voltage value (mV) provided to the analog input. Value range: 1... 10000 mV; Na - not available

Temp1... 8:

- **Value** - Temperature value of the area surrounding the temperature sensor. Value range: -125... 55 °C; Na - not available

5.2. SNMP Manager

The configured via Simple Network Management Protocol (SNMP v1.0) is carried out by transmitting the SET/GET message from SNMP Manager software to ELAN3-SNMP device. The tables provided in the following sections describe supported parameters, OIDs, actions available for each parameter which can be configured via SNMP as well as value range and an example/comment. Please, note that the tables reflect the parameters described in the sub-sections of **5.1. Web Browser**.

5.2.1. Network

Parameter name	OID	Access	Value	Example / comment
LAN IP Address	1.3.6.1.4.1.34093.1.2.10.1.0	get/set	IP address	e.g. 192.168.1.101
LAN Net Mask	1.3.6.1.4.1.34093.1.2.10.2.0	get/set	subnet IP	e.g. 255.255.255.0
Default Gateway	1.3.6.1.4.1.34093.1.2.10.3.0	get/set	gateway IP	e.g. 192.168.1.1
Local Web Server Port	1.3.6.1.4.1.34093.1.2.11.3.0	get/set	number	e.g. 80
Firmware version	1.3.6.1.4.1.34093.1.2.12.1.0	read	number	e.g. 80
DHCP	1.3.6.1.4.1.34093.1.2.11.5.0	get/set	0, 1	0 = disabled; 1 = enabled

5.2.2. Authentication

Parameter name	OID	Access	Value	Example / comment
Username	1.3.6.1.4.1.34093.1.2.11.1.0	get/set	text (16 chars max.)	e.g. user
Password	1.3.6.1.4.1.34093.1.2.11.2.0	get/set	text (16 chars max.)	e.g. psw1234

5.2.3. SNMP

Parameter name	OID	Access	Value	Example / comment
SysDescription	1.3.6.1.2.1.1.1.0	get/set	text (32 chars max.)	e.g. Inputs monitoring SNMP device
SysObjectID	1.3.6.1.2.1.1.2.0	get	1.3.6.1.4.1.34093.1.2	constant
SysUpTime	1.3.6.1.2.1.1.3.0	get	counter	e.g. 10778 seconds
SysContact	1.3.6.1.2.1.1.4.0	get/set	text (32 chars max.)	e.g. ELDES, Tel. No. +3701111111
SysName	1.3.6.1.2.1.1.5.0	get/set	text (32 chars max.)	e.g. ELAN3-SNMP device
SysLocation	1.3.6.1.2.1.1.6.0	get/set	text (32 chars max.)	e.g. Vilnius, Lithuania
Read/write community	1.3.6.1.4.1.34093.1.2.30.1.0	get/set	text (16 chars max.)	e.g. public
Trap Destination1	1.3.6.1.4.1.34093.1.2.31.1.0	get/set	IP address	e.g. 192.168.1.201
Trap Destination2	1.3.6.1.4.1.34093.1.2.31.2.0	get/set	IP address	e.g. 192.168.1.202
Trap Destination3	1.3.6.1.4.1.34093.1.2.31.3.0	get/set	IP address	e.g. 192.168.1.203

5.2.4. Inputs

Parameter name	OID	Access	Value	Example / comment
Input1 name	1.3.6.1.4.1.34093.1.2.60.1.0	get/set	text	e.g. Input-1
Input2 name	1.3.6.1.4.1.34093.1.2.60.2.0	get/set	text	e.g. Input-2
Input3 name	1.3.6.1.4.1.34093.1.2.60.3.0	get/set	text	e.g. Input-3
Input4 name	1.3.6.1.4.1.34093.1.2.60.4.0	get/set	text	e.g. Input-4
Input1 state ON name	1.3.6.1.4.1.34093.1.2.61.1.0	get/set	text	e.g. Input-1 is violated
Input2 state ON name	1.3.6.1.4.1.34093.1.2.61.2.0	get/set	text	e.g. Input-2 is violated
Input3 state ON name	1.3.6.1.4.1.34093.1.2.61.3.0	get/set	text	e.g. Input-3 is violated
Input4 state ON name	1.3.6.1.4.1.34093.1.2.61.4.0	get/set	text	e.g. Input-4 is violated
Input1 state OFF name	1.3.6.1.4.1.34093.1.2.62.1.0	get/set	text	e.g. Input-1 is restored
Input2 state OFF name	1.3.6.1.4.1.34093.1.2.62.2.0	get/set	text	e.g. Input-2 is restored
Input3 state OFF name	1.3.6.1.4.1.34093.1.2.62.3.0	get/set	text	e.g. Input-3 is restored
Input4 state OFF name	1.3.6.1.4.1.34093.1.2.62.4.0	get/set	text	e.g. Input-4 is restored
Input1 priority	1.3.6.1.4.1.34093.1.2.63.1.0	get/set	1...8	e.g. 2
Input2 priority	1.3.6.1.4.1.34093.1.2.63.2.0	get/set	1...8	e.g. 3
Input3 priority	1.3.6.1.4.1.34093.1.2.63.3.0	get/set	1...8	e.g. 8
Input4 priority	1.3.6.1.4.1.34093.1.2.63.4.0	get/set	1...8	e.g. 1
Input1 mode	1.3.6.1.4.1.34093.1.2.64.1.0	get/set	D, A	D = digital; A = analog
Input2 mode	1.3.6.1.4.1.34093.1.2.64.2.0	get/set	D, A	D = digital; A = analog
Input3 mode	1.3.6.1.4.1.34093.1.2.64.3.0	get/set	D, A	D = digital; A = analog
Input4 mode	1.3.6.1.4.1.34093.1.2.64.4.0	get/set	D, A	D = digital; A = analog
Digital Input1 type	1.3.6.1.4.1.34093.1.2.65.1.0	get/set	Nc, No	Nc = normally closed; No = normally open
Digital Input2 type	1.3.6.1.4.1.34093.1.2.65.2.0	get/set	Nc, No	Nc = normally closed; No = normally open
Digital Input3 type	1.3.6.1.4.1.34093.1.2.65.3.0	get/set	Nc, No	Nc = normally closed; No = normally open
Digital Input4 type	1.3.6.1.4.1.34093.1.2.65.4.0	get/set	Nc, No	Nc = normally closed; No = normally open
Digital Input1 - threshold	1.3.6.1.4.1.34093.1.2.66.1.0	get/set	1... 10000	e.g. 6000 mV
Digital Input2 - threshold	1.3.6.1.4.1.34093.1.2.66.2.0	get/set	1... 10000	e.g. 5000mV
Digital Input3 - threshold	1.3.6.1.4.1.34093.1.2.66.3.0	get/set	1... 10000	e.g. 2000mV
Digital Input4 - threshold	1.3.6.1.4.1.34093.1.2.66.4.0	get/set	1... 10000	e.g. 4000mV
Analog Input1 - delta	1.3.6.1.4.1.34093.1.2.67.1.0	get/set	1... 10000	e.g. 200 mV
Analog Input2 - delta	1.3.6.1.4.1.34093.1.2.67.2.0	get/set	1... 10000	e.g. 300 mV
Analog Input3 - delta	1.3.6.1.4.1.34093.1.2.67.3.0	get/set	1... 10000	e.g. 250 mV
Analog Input4 - delta	1.3.6.1.4.1.34093.1.2.67.4.0	get/set	1... 10000	e.g. 360 mV

5.2.5. Temperature Sensors

Parameter name	OID	Access	Value	Example / comment
Temp1 name	1.3.6.1.4.1.34093.1.2.410.1.0	get/set	text (16 chars max.)	e.g. Garage temp
Temp2 name	1.3.6.1.4.1.34093.1.2.411.1.0	get/set	text (16 chars max.)	e.g. Kitchen temp
Temp3 name	1.3.6.1.4.1.34093.1.2.412.1.0	get/set	text (16 chars max.)	e.g. Corridor temp
Temp4 name	1.3.6.1.4.1.34093.1.2.413.1.0	get/set	text (16 chars max.)	e.g. Attic temp
Temp5 name	1.3.6.1.4.1.34093.1.2.414.1.0	get/set	text (16 chars max.)	e.g. Basement temp
Temp6 name	1.3.6.1.4.1.34093.1.2.415.1.0	get/set	text (16 chars max.)	e.g. Dining room temp
Temp7 name	1.3.6.1.4.1.34093.1.2.416.1.0	get/set	text (16 chars max.)	e.g. Living room temp
Temp8 name	1.3.6.1.4.1.34093.1.2.417.1.0	get/set	text (16 chars max.)	e.g. Sleeping room
Temp5 Min value	1.3.6.1.4.1.34093.1.2.404.1.0	get/set	-55... 125	e.g. 20 °C
Temp5 Max value	1.3.6.1.4.1.34093.1.2.404.2.0	get/set	-55... 125	e.g. -30 °C
Temp6 Min value	1.3.6.1.4.1.34093.1.2.405.1.0	get/set	-55... 125	e.g. -15 °C
Temp6 Max value	1.3.6.1.4.1.34093.1.2.405.2.0	get/set	-55... 125	e.g. 18 °C
Temp7 Min value	1.3.6.1.4.1.34093.1.2.406.1.0	get/set	-55... 125	e.g. 22 °C
Temp7 Max value	1.3.6.1.4.1.34093.1.2.406.2.0	get/set	-55... 125	e.g. 10 °C
Temp8 Min value	1.3.6.1.4.1.34093.1.2.407.1.0	get/set	-55... 125	e.g. 2 °C
Temp8 Max value	1.3.6.1.4.1.34093.1.2.407.2.0	get/set	-55... 125	e.g. -4 °C

5.2.6. Outputs

Parameter name	OID	Access	Value	Example / comment
Output C1 control	1.3.6.1.4.1.34093.1.2.200.1.0	get/set	0, 1	0 = turn OFF output; 1 = turn ON output
Output C2 control	1.3.6.1.4.1.34093.1.2.200.2.0	get/set	0, 1	0 = turn OFF output; 1 = turn ON output

5.2.7. Monitoring

Parameter name	OID	Access	Value	Example / comment
Input1 status	1.3.6.1.4.1.34093.1.2.300.1.0	get/trap	0, 1, Na	0 = input is restored; 1 = input is violated; Na = not available
Input2 status	1.3.6.1.4.1.34093.1.2.300.2.0	get/trap	0, 1, Na	0 = input is restored; 1 = input is violated; Na = not available
Input3 status	1.3.6.1.4.1.34093.1.2.300.3.0	get/trap	0, 1, Na	0 = input is restored; 1 = input is violated; Na = not available
Input4 status	1.3.6.1.4.1.34093.1.2.300.4.0	get/trap	0, 1, Na	0 = input is restored; 1 = input is violated; Na = not available
Input1 value	1.3.6.1.4.1.34093.1.2.301.1.0	get/trap	1... 10000, Na	e.g. 6000 mV; Na = not available
Input2 value	1.3.6.1.4.1.34093.1.2.301.2.0	get/trap	1... 10000, Na	e.g. 6000 mV; Na = not available
Input3 value	1.3.6.1.4.1.34093.1.2.301.3.0	get/trap	1... 10000, Na	e.g. 6000 mV; Na = not available
Input4 value	1.3.6.1.4.1.34093.1.2.301.4.0	get/trap	1... 10000, Na	e.g. 6000 mV; Na = not available
Temp1 value	1.3.6.1.4.1.34093.1.2.400.3.0	get/trap	-55... 125	e.g. 15 °C
Temp2 value	1.3.6.1.4.1.34093.1.2.401.3.0	get/trap	-55... 125	e.g. 25 °C
Temp3 value	1.3.6.1.4.1.34093.1.2.402.3.0	get/trap	-55... 125	e.g. -42 °C
Temp4 value	1.3.6.1.4.1.34093.1.2.403.3.0	get/trap	-55... 125	e.g. 12 °C
Temp5 value	1.3.6.1.4.1.34093.1.2.404.3.0	get/trap	-55... 125	e.g. 4 °C
Temp6 value	1.3.6.1.4.1.34093.1.2.405.3.0	get/trap	-55... 125	e.g. 33 °C
Temp7 value	1.3.6.1.4.1.34093.1.2.406.3.0	get/trap	-55... 125	e.g. 18 °C
Temp8 value	1.3.6.1.4.1.34093.1.2.407.3.0	get/trap	-55... 125	e.g. -11 °C

6. TECHNICAL SUPPORT

6.1. Troubleshooting

Indication	Possible reason
Indicator STATUS is OFF	<ul style="list-style-type: none">· Power supply fault.· No mains power.· Micro-controller fault.
Indicators LAN(green) and LAN(yellow) are OFF	<ul style="list-style-type: none">· Bad Ethernet cable.· Ethernet router is switched OFF.
All indicators are ON or flashing, but unable to receive any trap message to SNMP Manager software	<ul style="list-style-type: none">· Wrong trap destination IP address / IP address not set.· Wrong SNMP Manager software configuration.· TCP/UDP port not forwarded on the router for ELAN3-SNMP device's IP address and/or your ISP is permanently blocking a certain TCP/UDP port (-s).

For product warranty repair service please, contact your local retail store where this product was purchased.

If your problem could not be fixed by the self-guide above, please contact your local distributor. More up to date information about your device and other products can be found at the manufacturer's website www.eldes.lt

6.2. Restoring Default Parameters

1. Power down the device.
2. Short-circuit (connect) the DEF pins.
3. Power up the device for 7 seconds.
4. Power down the device.
5. Remove the short-circuit from DEF pins.
6. Parameters restored to default.

6.3. Updating the Firmware via USB Cable

1. Power down the device.
2. Short-circuit (connect) the DEF pins.
3. Connect the device via USB cable to the PC.
4. Power up the device.
5. The new window must pop-up where you will find the .bin file. Otherwise open My Computer and look for Boot Disk drive.
6. Delete the .bin file found in the drive.
7. Copy the new firmware .bin file to the very same window.
8. Power down the device.
9. Unplug the USB cable.
10. Remove the short-circuit from DEF pins.
11. Power up the device.
12. Firmware updated.

NOTE: It is strongly recommended to restore default parameters after the firmware update.

