

E Model

Swagelok® industrial pressure transducers allow for electronic monitoring of system pressures in a variety of industrial applications. The E model transducer is specifically designed to meet durability and performance demands of industrial applications where explosion-proof ratings are required.



Introduction

Swagelok industrial pressure transducers allow for electronic monitoring of system pressures in a variety of industrial applications. The products feature an accuracy of 0.5 % Limit point calibration (0.25 % Best fit straight line), and temperature compensation to ensure accuracy and long term stability when exposed to temperature variations. The transducers are available in a wide variety of pressure connections, pressure ratings, pressure units, and signal outputs to fulfill many application requirements.

Contents

■ Safety Definitions	1
■ Safety Instructions	1
■ Mechanical Installation	2
■ Service and Maintenance	2
■ Electrical Installation	2
■ Wiring Diagrams	3
■ FM and CSA Approvals	3
■ Troubleshooting Guide	4

Safety Definitions



Potential danger to life or of serious injuries.



Potential danger to life or of serious injuries due to catapulting parts.



Potential danger of burns due to hot surfaces.



Notice, important information.



The product was tested and certified by CSA International. It complies with the applicable Canadian standards on safety.



The product was tested and certified by FM Approvals. It complies with the applicable U.S.A. standards on safety.

Safety Instructions



For proper and safe operation, Swagelok E model transducers must be installed, operated, and serviced according to NEC, applicable local regulations, and these instructions. Otherwise, serious personal injuries, damage or both can occur.



The electrical connection provided on the transducer should be used as originally supplied and not bypassed or modified (other than the cable length.) Improper installation or modification of the electrical connection will void the factory warranty and approval.



Do not exceed the overpressure rating.



Before servicing any installed pressure transducer you must

- depressurize system
- purge the transducer

Residual material may be left in the transducer and system.



Safe Product Use

Follow any enclosed instructions and refer to the product catalog for detailed product information. When using a transducer, the total system design must be considered to ensure safe, trouble-free performance. Function, material compatibility, adequate ratings, proper installation, operation, and maintenance are the responsibilities of the system designer and user. **Improper selection or misuse of the product may result in serious personal injury or property damage.**



Mechanical Installation



Check the transducer diaphragm visually for damage. Do not use the transducer if there is visual damage to the diaphragm.



Protect the diaphragm against any contact with abrasive substances, pressure peaks or tools. If you damage the diaphragm, the factory warranty and approval are no longer valid.

Using the appropriate mating process connection, install the transducer away from excessive heat and vibration whenever possible. Install the system in accordance with NEC requirements.



50 N·m (36 ft·lb) max

Service and Maintenance



Swagelok E model pressure transducers are tested and calibrated at the factory. There are no user serviceable components inside the case.



The surfaces of the pressure transducer may get hot during operation.



Liquid leaking from diaphragm is an indicator of diaphragm damage.

Electrical Installation



The shield / ground connection must be wired to ground to protect the instrument from electromagnetic disturbances.



Attempting to remove the cable connection will damage the transducer and void the factory warranty and approvals.



Do not exceed the maximum permissible power supply 30 V (dc).

- Connect the transducer to a power supply and an indicator or other recording device as shown below.
- Use a NEC Class 02 power supply
- Connect the cable shield or the yellow/green wire to ground.

4 to 20 mA, 2-Wire System.

Maximum Load Equations

Milliampere Output Signal, 2-Wire

Output	4 to 20 mA
Supply	$V = 10 \text{ to } 30 \text{ V (dc)}$
Max load	$R_L = (V [\text{dc}] - 10) / 0.02$
Terminals	See drawings

1 to 5 V, 3-Wire System

Load Equations

Voltage Output Signal, 3-Wire

Output	1 to 5 V
Supply	$V = 10 \text{ to } 30 \text{ V (dc)}$
Min Load	$R_L > 5 \text{ k}\Omega$
Terminals	See drawings

Wiring Diagram Legend

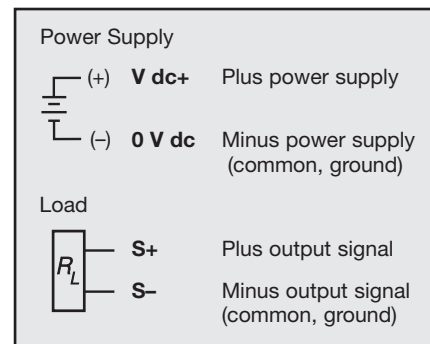

4 to 20 mA, 2-Wire System

The 2-wire system connects the power supply, transducer, and indicating/recording instrument in a series circuit. This creates a “current loop” with the transducer functioning as a current regulation device.

Wiring Diagram

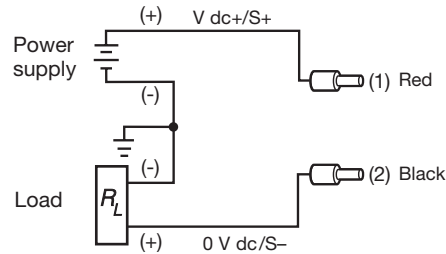

Wire	Coding	Color
Supply +	V dc+/S+	Red
Signal -	0 V dc/S-	Black

Use yellow/green wire or braided conductor for shield/ground connection.

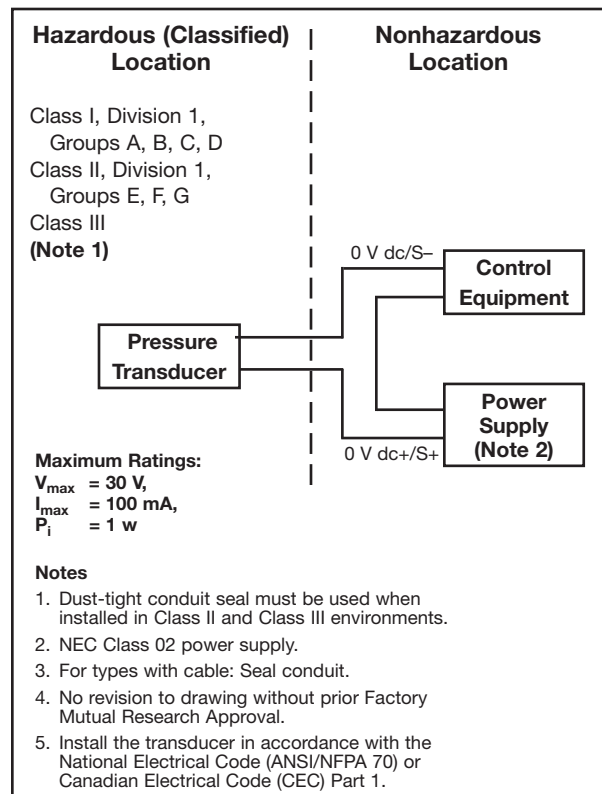

FM and CSA Approval



■ FM and CSA approval:

- Class I, Division 1, Groups A, B, C, D
- Class II/III, Division 1, Groups E, F, G

■ Temperature class:

- T6 at maximum ambient 140°F (60°C)
- T4 at maximum ambient 221°F (105°C)

1 to 5 V, 3-Wire System

The 3-wire system features separate leads for the signal and power supply. The third lead is common negative for both devices. The signal source and indication/recording instruments are connected in series, the power supply in parallel.

Wiring Diagram

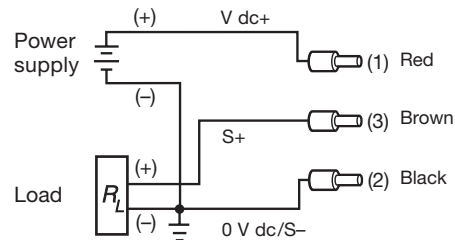

Wire	Coding	Color
Supply +	V dc+	Red
Supply - Signal -	0 V dc/S-	Black
Signal +	S+	Brown

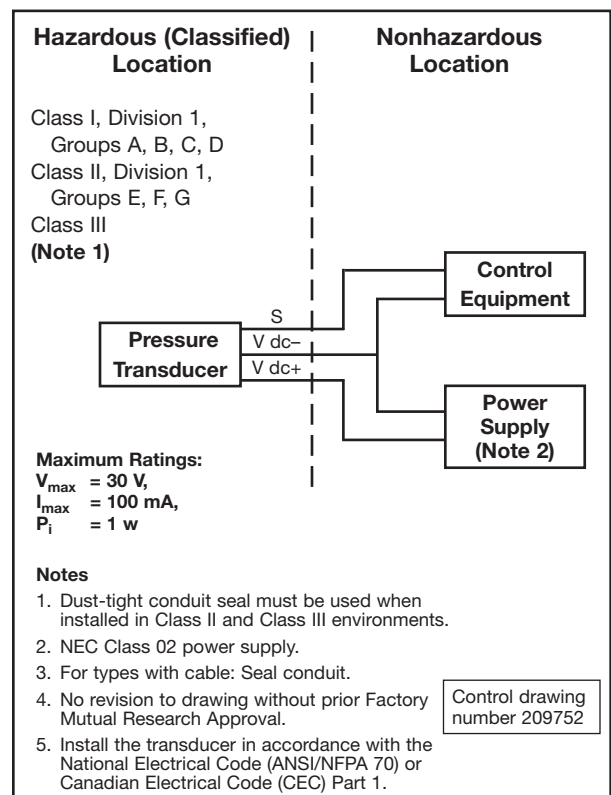

Troubleshooting Guide



Before servicing any installed pressure transducer you must

- depressurize system
- purge the transducer

Residual material may be left in the transducer and system.



- If the transducer becomes damaged or unsafe for operation, remove it from service and mark to prevent it from being used accidentally.
- Have repairs performed by the manufacturer only.



Do not insert any pointed or hard objects into the pressure port for cleaning.

Problem	Possible Causes	Remedy
No output	Power supply failure	Check power supply
	Open wiring	Check continuity
	Wiring reversed	Correct polarity
	No pressure or port blocked	Check pressure port
	Transducer failure due to wrong supply voltage or power surge	Replace transducer
Output steady as pressure changes	Pressure port blocked	Check pressure port
	Transducer over-pressurized	Replace transducer
	Transducer failure due to wrong supply voltage or power surge	Replace transducer
Full span output low	Supply voltage too low	Check voltage supply
	Load impedance wrong	Adjust load or supply voltage
	Transducer overpressurized	Replace transducer ^①
Zero signal too low	Transducer overpressurized	Replace transducer ^①
Zero signal too high	Transducer overpressurized	Replace transducer ^①
Non-linear output	Transducer overpressurized	Replace transducer

^① Adjusting the controller or display device can usually compensate for small changes in the output signal. Test the system for proper operation after adjustments are made. An excessive change in the output signal indicates possible transducer damage. This may cause the output to be non-linear, requiring transducer replacement.

Storage and Disposal



Purge all media from the pressure transducer before storage or disposal of the transducer.



Mount the protection cap when storing a flush diaphragm pressure transducer to prevent damage.



Dispose of transducer components and packaging materials in accordance with the respective waste treatment and disposal regulations of the region or country to which the transducer is supplied.



Do not mix or interchange parts with those of other manufacturers.

Swagelok Company
29500 Solon Road
Solon Ohio 44139 U. S. A.

Authorized Representative in Europe:

Swagelok A.G.—Manufacturing Tech Center /
Distribution Center
P.O. Box 552
CH-8853 Lachen, Switzerland

For product technical data, including materials of construction, see the *Swagelok Industrial Pressure Transducers* catalog, MS-02-225.

Translations available on www.swagelok.com.

Swagelok—TM Swagelok Company
© 2004, 2008 Swagelok Company
MS-CRD-PTI-E, R2
November 2008