

LUMBERJACK TOOLS

Made in the USA

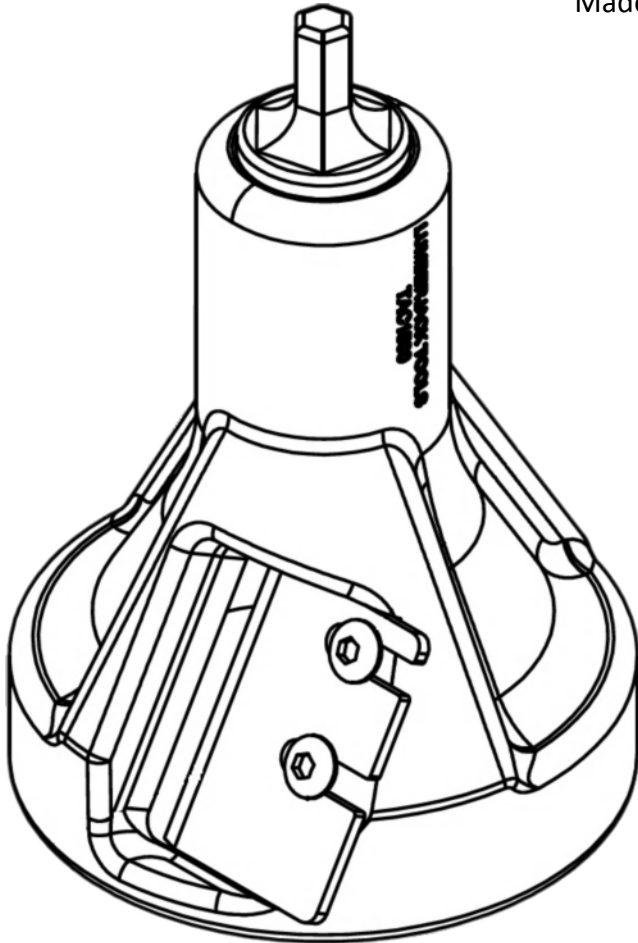

USER MANUAL COMMERCIAL SERIES (60° Shoulder Profile) Dual Blade Tenon Cutters

Lumberjack Tools Inc.
PO Box 730
Chippewa Falls, WI 54729
www.lumberjacktools.com
Email: info@lumberjacktools.com
Phone: 715-720-4719



MODELS:

Commercial Series TAC1000
Commercial Series TAC1500
Commercial Series TAC2000

Rev: 05/14

About Your Product

Thank you for purchasing our Dual Blade – Commercial Series Tenon Cutter!

Lumberjack engineers, along with our craftsmen, have designed the safest, easy to-use tenon cutters on the market. By combining old-world skills, along with DFMA principles and CNC technology, we've eliminated the issues of off-center tenons and side-load cutting associated with single-blade designs.

We've added value with the dual-blade technology which will cut the tenon in half the time. Having two blades, allows them to stay sharper, longer. The aluminum body is die-cast and CNC machined to ensure precise cutting each and every time. The blades are stamped, heat treated and precision ground to provide years of service when properly maintained.

Warranty

Our lifetime guarantee covers the tool body and shank. The blades are covered for 90 days from the date of purchase for breakage under normal working conditions. Blade sharpness is based on the type of wood (peeled or unpeeled). Grit, dirt, etc., will impact how long your blades stay sharp, and is not covered under this warranty. When making a claim, you must show proof of purchase from an authorized distributor. This is valid only to the original buyer, and not for tools sold secondhand, used, or sold "as is" to a second party.

SAFETY!



Before beginning any project, carefully read and follow all safety and operational instructions for any tools or devices you will be using. Failure to follow ALL safety instructions may cause physical harm to yourself or those around you. If you feel uncomfortable using our tenon cutter or any other tools, STOP immediately. Lumberjack Tools assumes no responsibility for injury caused to the operator, bystander or tools used in conjunction with the use or misuse of our tenon cutters.

- Never operate this tool under the influence of alcohol, drugs or medication.
- You must wear safety glasses, a dust mask, and any other personal safety accessories you deem necessary.
- Before installing/removing the tool, the drill must come to a complete stop and the power must be disconnected.
- Do not wear gloves, loose clothing or other items that may get caught in the moving parts.
- Never operate this tool in a drill press, lathe or any other device except for a ½" drill. Doing so voids the warranty.
- We recommend a single-speed drill with RPMs of 500 or less. It should be a gear-driven drill and not a variable-speed drill.
- Overloading or exceeding the RPM's can result in annealing the blade or shank failure.
- The log must be secured in a vise or clamp prior to starting your drill. Failure to do so may result in bodily harm.
- Do not run the tool into a nail or foreign object. Doing so may ruin the blades or tool, and voids the warranty.
- Do not alter or misuse this tool in any fashion.
- Remember the blades are sharp. Use caution when handling.
- Do not apply side force on the drill while in operation or it could result in premature shank failure or blade damage.
- This tool must be maintained by keeping the blades sharp and clean of buildup.
- When excessive force is required to cut, re-sharpen or replace the blades. A sharp tool is a safe tool!
- Under sever working conditions, while cutting tough, dry or knotty logs, side loading the tool may cause the shank to fail, or may result in blade damage.

Assembly Parts Included:

4 - Cap Screws



2 - Blades

Allen Wrench

Blade Assembly/Setting

1. Insert the allen wrench (included) into the cap screw and tighten the screw

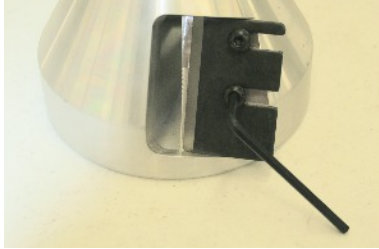

2. Make sure the blade gap setting is the same distance apart for both blades (about 1/8" - 1/4") **See below**
3. You can slightly change the tenon diameter by sliding the blade in or out. Sliding it in will reduce the diameter, and sliding it back will increase the diameter. **DO NOT** slide it beyond 1/4" from the face of the cutout. Doing so will not cut a tenon, as the blade must be exposed



RIGHT



RIGHT



WRONG

4. If the bit is too aggressive or stops your drill while cutting, you can remove one blade from the tool and operate it with one blade

Securely tighten the cap screw, but take caution not to strip it (do not over tighten). Re-check both screws before starting.

How to Specify the Tenon Length

The process of cutting a tenon to a specified length while incorporating the radius shoulder is as follows:

- Drill the mortise hole in the log you want to make a tenon joint.
 - Note: The depth of the hole should be $\frac{1}{3}$ " to $\frac{1}{2}$ " the diameter of the log.
- Measure the depth of the hole and subtract $\frac{1}{8}$ ". You want the tenon to "float" in the mortise hole and not "bottom out". This length is your tenon length

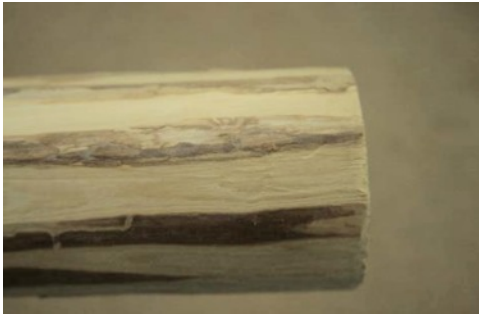

- Take the measured tenon length and add $\frac{1}{2}$ " to account for the radius shoulder. This is the overall length to mark on the log.
 - Example: To make a 1" long tenon joint ($1" + \frac{1}{2}"$ (for the shoulder) = $1\frac{1}{2}"$ mark on the log)



Getting Started

WARNING: Securing the log is probably the most IMPORTANT safety factor that will arise while building log furniture.

- Obtain the log you want to tenon. Cut it to length and make sure the end is flat. If the end is not even/flat, the tenon will be crooked



- Secure the log in a vise, or clamp it to a table in a V-shaped notch



- Carefully install the tenon cutter into an unplugged 1/2" or 3/4" drill, and tighten it firmly. A T-handle is also recommended
- Anytime you adjust the blades, or retighten the chuck, you must ALWAYS unplug the drill

Tips for Making Log Tenon Joints

Tip 1: Drilling Components

- Cut components to lengths
- Drill holes (mortise) in components using a forstner or spade bit at locations dimensioned on the plan
- Drill depth for mortise equals one-third to one-half diameter unless otherwise specified
- Hold drill perpendicular and straight to the log



Tip 2: Prepping Tenon

- Measure depth of mating mortise hole, then subtract 1/4"
- If the log is larger than the cutter will accept, taper down the end using the draw knife



Tip 3: Cutting Tenon

- Cutting a straight tenon is very important to minimize assembly issues (*see below*)

RIGHT

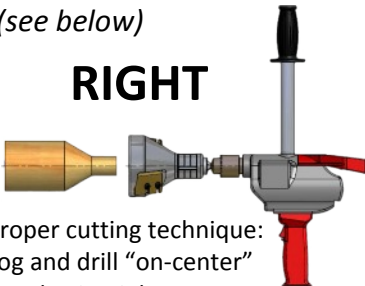

Proper cutting technique:
Log and drill "on-center"
Result - Straight Tenon

WRONG

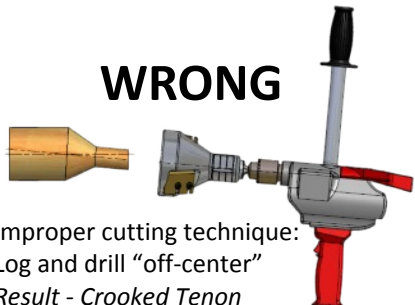

Improper cutting technique:
Log and drill "off-center"
Result - Crooked Tenon

Cutting Tenons

- If the log diameter is greater than what the tool will accept, use a draw knife to taper the end of the log, as one would sharpen a pencil, to get the tool started
- With your log securely clamped, position the tenon cutter face, squarely against the log you're going to tenon

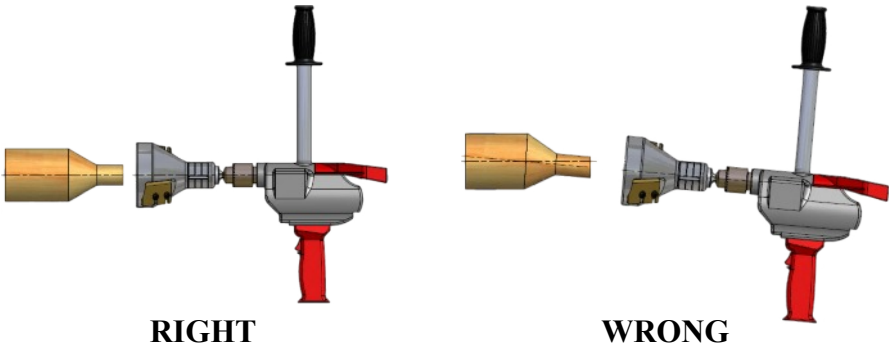

- Do NOT depress the trigger or start the drill before positioning it against the log. Doing so could harm yourself or the tool
- While holding the drill squarely against the log, apply body pressure (straight in-line) with the drill and depress the trigger
 - NOTE: Apply quite a bit of force. Lean into the drill so that it does not jump around or skip off the log
- You should not be cutting your tenon to the desired length
- Once the cutting has begun, you may ease up on the pressure, and the dual-blade technology will assist you in “pulling” the tool into the log
- WARNING: If the log comes loose or unclamped while making the tenon, DO NOT drop the drill or try to grab the log. Hang on the drill and point it in a safe direction (usually towards the ground), away from everyone until it comes to a complete stop

- Do not remove the tool from the log until the drill comes to a complete stop. Failure to do so will waffle cut the tenon or cause harm to the operator. Do not place hands or body parts near the tool or blades while in operation
- Do not drop or allow the tool to fall to the floor by itself or while in the drill. Doing so may bend the shank or damage the tool. This damage is not covered by the warranty

Maintenance

It is best if you keep the tenon cutter body clean of sap and build up. Remove the blades from the tool first. Carefully clean the tool with the solvent or cleaner of your choice, and dry when completed.

The blades are made from high-quality tool steel, and may form oxidation. This is a natural occurrence and will vary depending on your geographic location, climate and shop environment. You should periodically clean the blades and apply a thin film of oil.

Re-sharpening the blades: Wear safety glasses, and use caution when sharpening the blades. Every time you re-sharpen the blades, you must apply a thin film of oil. Use extreme caution so not to cut yourself.

We recommend our Blade Boss Jig (BB2500) for sharpening the blades.
(BB2500 Not Included)



Shank: One of the unique features about our tenon cutters is that they offer a replaceable shank. In the rare instance that your shank breaks, we offer replacement shanks for sale so you don't have to replace the entire tenon cutter. The shanks are threaded, so to loosen them, turn the shank to the left

Troubleshooting

TOOL SKIPS OFF TO ONE SIDE OR BOUNCES AROUND

- Log is larger than what the tool will accept
- Not enough body pressure is being applied
- Drill running prior to positioning the log. You must have the drill positioned against the log, apply body pressure, then start the drill

NOT CUTTING

- Blades are slid back too far - not grabbing
- Not applying enough body pressure
- Blades are dull

TAKES TOO MUCH OF A "BITE"

- Remove one blade or "shim" up no more than .020"

DRILL STOPS OR CUTS ON SMALL DIAMETER LOGS BUT NO LARGER ONES

- This is caused by using a variable speed drill
- Too high of RPM
- This may also be caused by using a non-Milwaukee brand drill
 - ❑ DeWalt, Makita, Rigid, Etc have less torque than Milwaukee

CROOKED JOINT

- This is from holding the drill crooked to the log

SPIRAL GROOVES ON THE TENON JOINT

- This is caused by wobbling the drill side to side while cutting

OR

- Removing the cutter from the log while the drill is still spinning

Additional Tips

As with any new hobby or project, it will take time to master using our tools, and building furniture. You must first have a plan or a sketch of what you want to build, along with a tools and materials list before you begin.

Another important issue is reading the natural twist, stress or other deformities in the logs and using these skills to your advantage, allowing your pieces to become more unique as your abilities grow. It is also important is to not over complicate your first few pieces, so you can have a “positive” experience.

Before starting your first project, use some scrap material and “practice” cutting tenons and using tools. Make sure you are comfortable operating the drill and cutters before you begin the project.

Thank you again for purchasing our tools!

