

Blast Chiller

Main Features

SMART CHILL - Variable air velocity.

RC11 - 11kg Blast Chill capacity per cycle.

RC25 - 25kg Blast Chill capacity per cycle.

Food product is required to be correctly portioned in Gastronorm pans.

- Removable and adjustable shelf runners able to accept Gastronorm pans.
- Temperature display in °C.
- Mode selection timer or four point Frigiprobe by internal food temperature.
- Automatic preservation mode at the end of cycle.
- Defrost feature removes ice from evaporator.
- R404A refrigerant - CFC free.
- Self-closing door magnetically seals. Door remains open past 90°C for convenient loading and unloading.
- Internal coved corners, removable door gasket.
- Water protection index rating IP459.
- Adjustable legs for levelling.
- Temperature recorder with printer (optional).

RR11A Air cooled condensing unit

RR25A Air cooled condensing unit

RR25S Remote condensing unit version

(Remote condensing unit not included.)

Description

Foodservice & Bakery Reach-In Blast Chiller/Freezer designed to accept Gastronorm 1/1 pans



RR11A Blast Chill



RR25A Blast Chill

SMARTCHILL

**The Smarter
Way to Chill**

Specifications

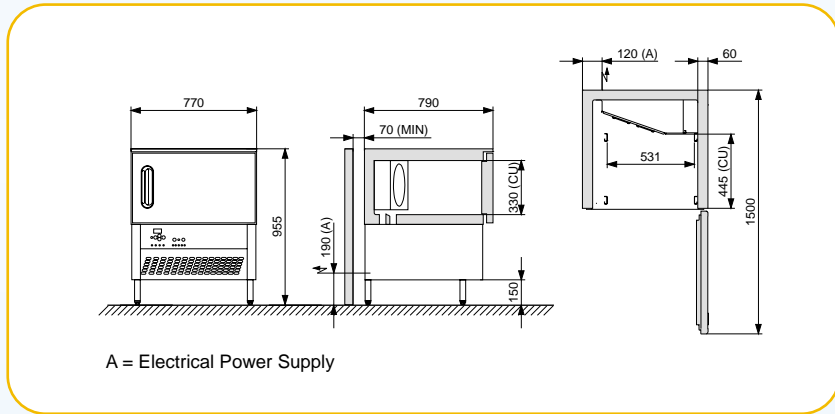

RR11A

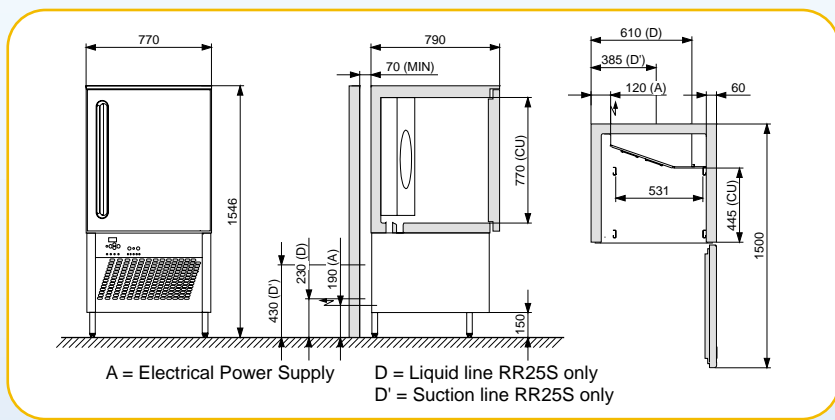

RR25A RR25S

Refrigeration Equipment RR25S only

- Complete remote condensing unit. Suitable for local conditions.
- Condensing capacity upright Blast Chiller 930/1900W for the respective evaporation temperatures of -20/0°C.
- Remote condensing unit with 'pump down' control.

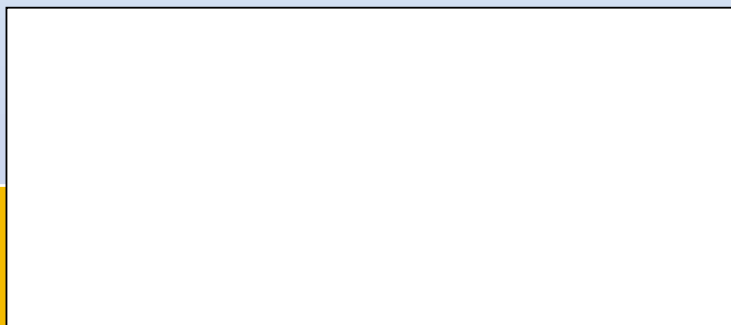

Disclaimer:

All unit capacities are based on subjective testing. Moffat accepts no liability for production values.



www.moffat.com.au

Australia Moffat Pty Ltd

Victoria/Tasmania
740 Springvale Road
Mulgrave, Victoria 3170
Telephone 03-9518 3888
Facsimile 03-9518 3833
Email vsales@moffat.com.au
www.moffat.com.au

New South Wales
Telephone 02-8833 4111
Email nswsales@moffat.com.au

South Australia
Telephone 08-8274 2116
Email dmiller@moffat.com.au

Queensland
Telephone 07-3630 8600
Email qldsals@moffat.com.au

Western Australia
Telephone 08-9305 8855
Email jberent@moffat.com.au

New Zealand Moffat Ltd

Christchurch
Telephone 03-389 1007
Email sales@moffat.co.nz
www.moffat.co.nz

Auckland
Telephone 09-574 3150
Email sales@moffat.co.nz