

Blast Chiller & Freezer

Main Features

SMART CHILL - Variable air velocity.

RC50-26 - 50kg Blast Chill capacity per cycle
or 25kg Blast Freeze capacity per cycle.

RC70-36 - 70kg Blast Chill capacity per cycle
or 50kg Blast Freeze capacity per cycle.

Food product is required to be correctly portioned
in Gastronorm pans/bakery trays.

- Removable and adjustable shelf runners able to accept Gastronorm pans and Euro standard 600mm x 400mm bakery trays.
- Temperature display in °C.
- Mode selection timer or four point Frigiprobe by internal food temperature.
- Automatic preservation mode at the end of cycle.
- Defrost feature removes ice from evaporator.
- R404A refrigerant - CFC free.
- Self-closing door magnetically seals. Door remains open past 90°C for convenient loading and unloading.
- Internal covered corners, removable door gasket.
- Water protection index rating IP459.
- Adjustable legs for levelling.

RC50-26A Air cooled condensing unit

RC50-26S Remote condensing unit version
(Remote condensing unit not included.)

RC70-36A Air cooled condensing unit

RC70-36S Remote condensing unit version
(Remote condensing unit not included.)

Description

Foodservice & Bakery Reach-In Blast Chiller/Freezer designed to accept Gastronorm 1/1 pans or Euro 600mm x 400mm bakery racks.

SMARTCHILL



RC50-26A Blast Chill/Freeze



RC70-36A Blast Chill/Freeze

MOFFAT
FRIGINOX
FAST CHILL/FREEZE



**The Smarter
Way to Chill**

Specifications

RC50-26A, RC50-26S

Dimensions

W 770mm x D 790mm x H 1906mm

Kg capacity per cycle

Blast chilling from +70°C to +3°C temperature, capacity per cycle 50kg
Blast freezing from +70°C to -18°C temperature, capacity per cycle 25kg

Electrical rating

A; 400 - 415Vac 3P+N+E 50Hz 4000W
S; 230 - 240Vac 1P+N+E 50Hz 580W

Refrigerant type

R404A

Standard pan capacity

14 GN 1/1 capacity
14 Euro 600mm x 400mm
Please specify when ordering

Clearances

Top 70mm; Side 70mm

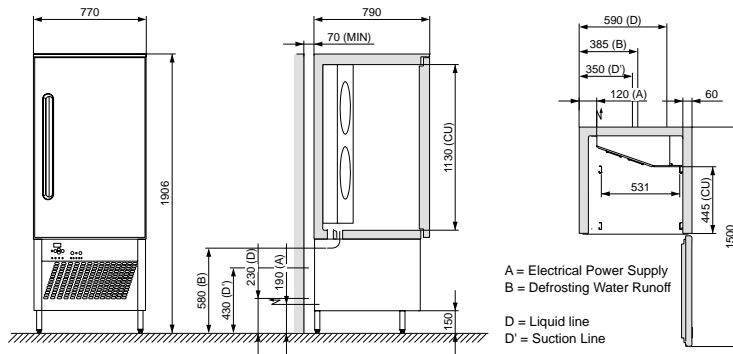

RC50-26A, RC50-26S

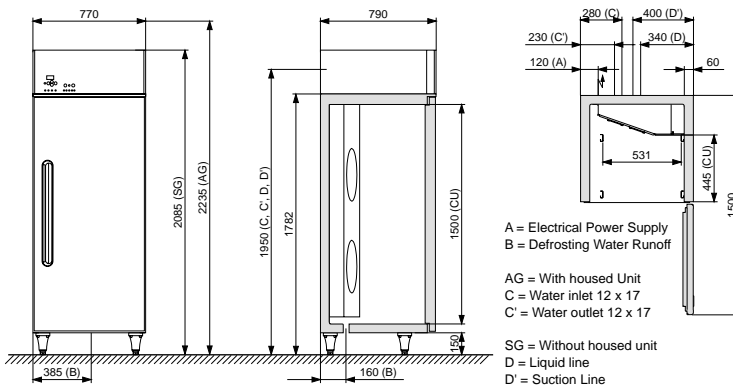

RC70-36A, RC70-36S

Refrigeration Equipment RC50-26S only

- Complete remote condensing unit. Suitable for local conditions.
- Condensing capacity upright Blast Chiller 1000/3500W for the respective evaporation temperatures of -40/-20°C.
- Remote condensing unit with 'pump down' control.

Refrigeration Equipment RC70-36S only

- Complete remote condensing unit. Suitable for local conditions.
- Condensing capacity upright Blast Chiller 2700/8600W for the respective evaporation temperatures of -40/-20°C.
- Remote condensing unit with 'pump down' control.



RC70-36A, RC70-36S

Dimensions

W 770mm x D 790mm x H 2085mm

Kg capacity per cycle

Blast chilling from +70°C to +3°C temperature, capacity per cycle 70kg
Blast freezing from +70°C to -18°C temperature, capacity per cycle 50kg

Electrical rating

A; 400 - 415Vac 3P+N+E 50Hz 6100W
S; 230 - 240Vac 1P+N+E 50Hz 580W

Refrigerant type

R404A

Standard pan capacity

19 GN 1/1 capacity
19 Euro 600mm x 400mm
Please specify when ordering

Clearances

Top 70mm; Side 70mm

Disclaimer:

All unit capacities are based on subjective testing. Moffat accepts no liability for production values.



Australia
Moffat Pty Ltd

Victoria/Tasmania
740 Springvale Road
Mulgrave, Victoria 3170
Telephone 03-9518 3888
Facsimile 03-9518 3833
Email vsales@moffat.com.au
www.moffat.com.au

New South Wales
Telephone 02-8833 4111
Email nswsales@moffat.com.au

South Australia
Telephone 08-8274 2116
Email dmiller@moffat.com.au

Queensland
Telephone 07-3630 8600
Email qldsales@moffat.com.au

Western Australia
Telephone 08-9305 8855
Email jberent@moffat.com.au

New Zealand
Moffat Ltd

Christchurch
Telephone 03-389 1007
Email sales@moffat.co.nz
www.moffat.co.nz

Auckland
Telephone 09-574 3150
Email sales@moffat.co.nz