

Blast Chiller & Freezer

Main Features

SMART CHILL - Variable air velocity.

RC15-7A - 15kg Blast Chill capacity per cycle or 9kg Blast Freeze capacity per cycle.

RC30-15 - 30kg Blast Chill capacity per cycle or 15kg Blast Freeze capacity per cycle.

Food product is required to be correctly portioned in Gastronorm pans/bakery trays.

- Removable and adjustable shelf runners able to accept Gastronorm pans and Euro standard 600mm x 400mm bakery trays.
- Temperature display in °C.
- Mode selection timer or four point Frigiprobe by internal food temperature.
- Automatic preservation mode at the end of cycle.
- Defrost feature removes ice from evaporator.
- R404A refrigerant - CFC free.
- Self-closing door magnetically seals. Door remains open past 90°C for convenient loading and unloading.
- Internal coved corners, removable door gasket.
- Water protection index rating IP459.
- Adjustable legs for levelling.
- Temperature recorder with printer (optional).

RC15-7A Air cooled condensing unit

RC30-15A Air cooled condensing unit

RC30-15S Remote condensing unit version

(Remote condensing unit not included.)

Description

Foodservice & Bakery Reach-In Blast Chiller/Freezer designed to accept Gastronorm 1/1 pans or Euro 600mm x 400mm bakery racks.



RC15-7A Blast Chill/Freeze



RC30-15A Blast Chill/Freeze

SMARTCHILL

**The Smarter
Way to Chill**

Specifications

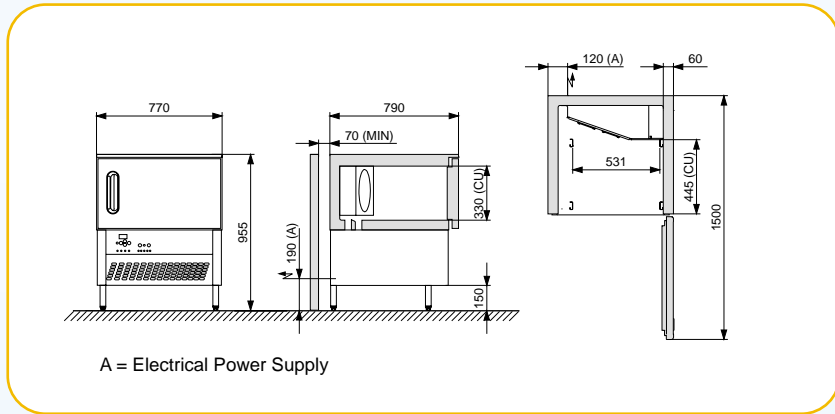

RC15-7A

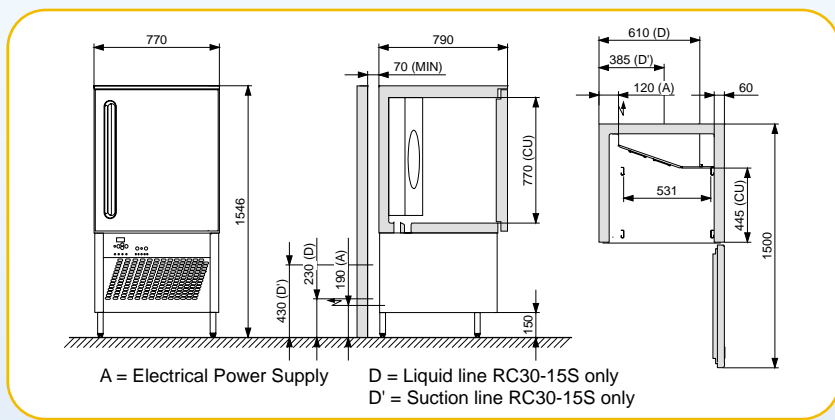

**RC30-15A
RC30-15S**

Refrigeration Equipment RC30-15S only

- Complete remote condensing unit. Suitable for local conditions.
- Condensing capacity upright Blast Chiller 400/1150W for the respective evaporation temperatures of -40/-20°C.
- Remote condensing unit with 'pump down' control.

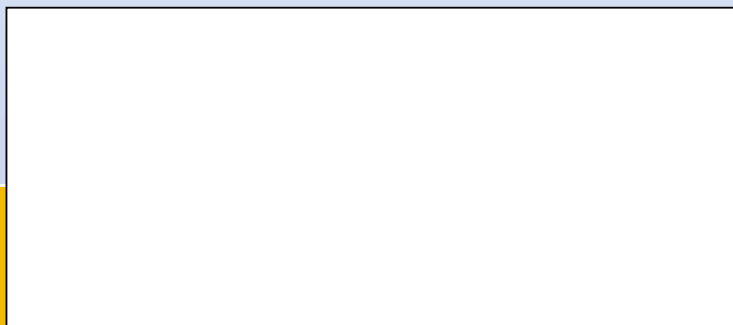

RC15-7A

Dimensions

W 770mm x D 790mm x H 965mm

Kg capacity per cycle

Blast chilling from +70°C to +3°C temperature, capacity per cycle 15kg
Blast freezing from +70°C to -18°C temperature, capacity per cycle 9kg

Electrical rating

230 - 240Vac 1P+N+E 50Hz 2100W

Refrigerant type

R404A

Standard pan capacity

4 GN 1/1 capacity
4 Euro 600mm x 400mm
Please specify when ordering

Clearances

Top 70mm; Side 70mm

RC30-15A, RC30-15S

Dimensions

W 770mm x D 790mm x H 1546mm

Kg capacity per cycle

Blast chilling from +70°C to +3°C temperature, capacity per cycle 30kg
Blast freezing from +70°C to -18°C temperature, capacity per cycle 15kg

Electrical rating

230 - 240Vac 1P+N+E 50Hz
A 2280W; S 425W

Refrigerant type

R404A

Standard pan capacity

8 GN 1/1 capacity
8 Euro 600mm x 400mm
Please specify when ordering

Clearances

Top 70mm; Side 70mm

Disclaimer:

All unit capacities are based on subjective testing. Moffat accepts no liability for production values.



www.moffat.com.au

**Australia
Moffat Pty Ltd**

Victoria/Tasmania
740 Springvale Road
Mulgrave, Victoria 3170
Telephone 03-9518 3888
Facsimile 03-9518 3833
Email vsales@moffat.com.au
www.moffat.com.au

New South Wales
Telephone 02-8833 4111
Email nswsales@moffat.com.au

South Australia
Telephone 08-8274 2116
Email dmiller@moffat.com.au

Queensland
Telephone 07-3630 8600
Email qldsals@moffat.com.au

Western Australia
Telephone 08-9305 8855
Email jberent@moffat.com.au

**New Zealand
Moffat Ltd**

Christchurch
Telephone 03-389 1007
Email sales@moffat.co.nz
www.moffat.co.nz

Auckland
Telephone 09-574 3150
Email sales@moffat.co.nz