

RFID System

V680 Series

User's Manual for Amplifiers, Antennas, and ID Tags (EEPROM)

Amplifier and Antennas

- V680-HA63A
- V680-HS51
- V680-HS52
- V680-HS63
- V680-HS65

ID Tags

- V680-D1KP52MT
- V680-D1KP66T
- V680-D1KP66MT
- V680-D1KP66T-SP

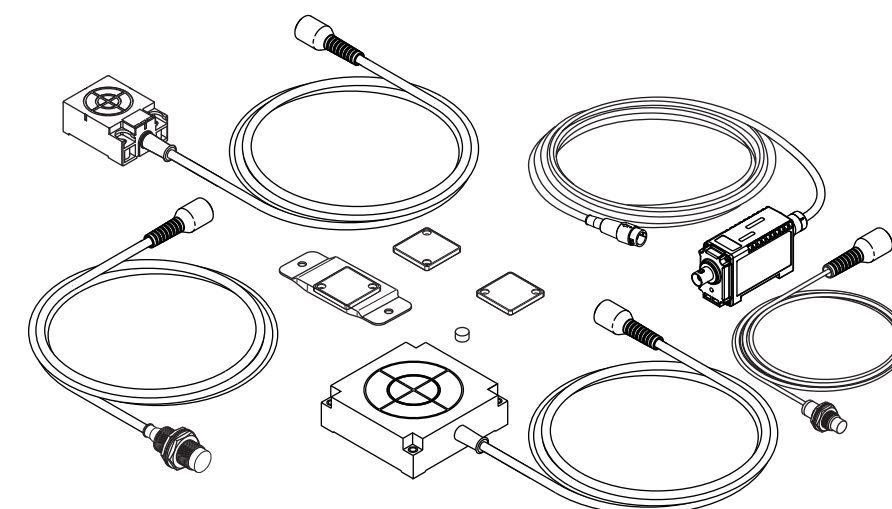

OMRON

OMRON Corporation
Industrial Automation Company

Sensing Devices Division H.Q.
Industrial Sensors Division
Shiokoji Horikawa, Shimogyo-ku,
Kyoto, 600-8530 Japan
Tel: (81)75-344-7022/Fax: (81)75-344-7107

Regional Headquarters

OMRON EUROPE B.V.
Sensor Business Unit
Carl-Benz-Str. 4, D-71154 Nufringen,
Germany
Tel: (49) 7032-811-0/Fax: (49) 7032-811-199

OMRON ELECTRONICS LLC
One Commerce Drive Schaumburg,
IL 60173-5302 U.S.A.
Tel: (1) 847-843-7900/Fax: (1) 847-843-7787

OMRON ASIA PACIFIC PTE. LTD.
No. 438A Alexandra Road # 05-05/08 (Lobby 2),
Alexandra Technopark, Singapore 119967
Tel: (65) 6835-3011/Fax: (65) 6835-2711

OMRON (CHINA) CO., LTD.
Room 2211, Bank of China Tower,
200 Yin Cheng Zhong Road,
Pu Dong New Area, Shanghai, 200120, China
Tel: (86) 21-5037-2222/Fax: (86) 21-5037-2200

In the interest of product improvement, specifications are subject to change without notice.

Authorized Distributor:

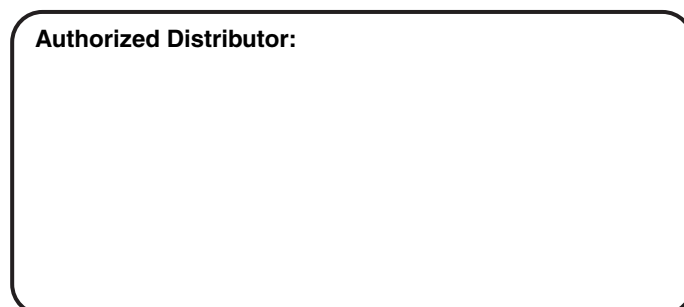

Introduction

Thank you for purchasing a V680-series RFID System. This manual describes the functions, performance, and application methods needed for optimum use of the V680-series RFID System.

Please observe the following items when using the RFID System.

- Allow the RFID System to be installed and operated only by qualified specialist with a sufficient knowledge of electrical systems.
- Read and understand this manual before attempting to use the RFID System and use the RFID System correctly.
- Keep this manual in a safe and accessible location so that it is available for reference when required.

Introduction	READ AND UNDERSTAND THIS DOCUMENT	Introduction
Section 1	Product Overview	Section 1
Section 2	Specifications and Performance	Section 2
Section 3	Communications Specifications	Section 3
Section 4	Installation	Section 4
Section 5	Chemical Resistance	Section 5

RFID System

V680-HA63A	Amplifier
V680-HS51	Antenna
V680-HS52	Antenna
V680-HS63	Antenna
V680-HS65	Antenna
V680-D1KP52MT	ID Tag
V680-D1KP66T	ID Tag
V680-D1KP66MT	ID Tag
V680-D1KP66T-SP	ID Tag

User's Manual

READ AND UNDERSTAND THIS DOCUMENT

Please read and understand this document before using the products. Please consult your OMRON representative if you have any questions or comments.

WARRANTY

OMRON's exclusive warranty is that the products are free from defects in materials and workmanship for a period of one year (or other period if specified) from date of sale by OMRON.

OMRON MAKES NO WARRANTY OR REPRESENTATION, EXPRESS OR IMPLIED, REGARDING NON-INFRINGEMENT, MERCHANTABILITY, OR FITNESS FOR PARTICULAR PURPOSE OF THE PRODUCTS. ANY BUYER OR USER ACKNOWLEDGES THAT THE BUYER OR USER ALONE HAS DETERMINED THAT THE PRODUCTS WILL SUITABLY MEET THE REQUIREMENTS OF THEIR INTENDED USE. OMRON DISCLAIMS ALL OTHER WARRANTIES, EXPRESS OR IMPLIED.

LIMITATIONS OF LIABILITY

OMRON SHALL NOT BE RESPONSIBLE FOR SPECIAL, INDIRECT, OR CONSEQUENTIAL DAMAGES, LOSS OF PROFITS OR COMMERCIAL LOSS IN ANY WAY CONNECTED WITH THE PRODUCTS, WHETHER SUCH CLAIM IS BASED ON CONTRACT, WARRANTY, NEGLIGENCE, OR STRICT LIABILITY.

In no event shall responsibility of OMRON for any act exceed the individual price of the product on which liability is asserted.

IN NO EVENT SHALL OMRON BE RESPONSIBLE FOR WARRANTY, REPAIR, OR OTHER CLAIMS REGARDING THE PRODUCTS UNLESS OMRON'S ANALYSIS CONFIRMS THAT THE PRODUCTS WERE PROPERLY HANDLED, STORED, INSTALLED, AND MAINTAINED AND NOT SUBJECT TO CONTAMINATION, ABUSE, MISUSE, OR INAPPROPRIATE MODIFICATION OR REPAIR.

SUITABILITY FOR USE

THE PRODUCTS CONTAINED IN THIS DOCUMENT ARE NOT SAFETY RATED. THEY ARE NOT DESIGNED OR RATED FOR ENSURING SAFETY OF PERSONS, AND SHOULD NOT BE RELIED UPON AS A SAFETY COMPONENT OR PROTECTIVE DEVICE FOR SUCH PURPOSES. Please refer to separate catalogs for OMRON's safety rated products.

OMRON shall not be responsible for conformity with any standards, codes, or regulations that apply to the combination of products in the customer's application or use of the product.

At the customer's request, OMRON will provide applicable third party certification documents identifying ratings and limitations of use that apply to the products. This information by itself is not sufficient for a complete determination of the suitability of the products in combination with the end product, machine, system, or other application or use.

The following are some examples of applications for which particular attention must be given. This is not intended to be an exhaustive list of all possible uses of the products, nor is it intended to imply that the uses listed may be suitable for the products:

- Outdoor use, uses involving potential chemical contamination or electrical interference, or conditions or uses not described in this document.
- Nuclear energy control systems, combustion systems, railroad systems, aviation systems, medical equipment, amusement machines, vehicles, safety equipment, and installations subject to separate industry or government regulations.
- Systems, machines, and equipment that could present a risk to life or property.

Please know and observe all prohibitions of use applicable to the products.

NEVER USE THE PRODUCTS FOR AN APPLICATION INVOLVING SERIOUS RISK TO LIFE OR PROPERTY WITHOUT ENSURING THAT THE SYSTEM AS A WHOLE HAS BEEN DESIGNED TO ADDRESS THE RISKS, AND THAT THE OMRON PRODUCT IS PROPERLY RATED AND INSTALLED FOR THE INTENDED USE WITHIN THE OVERALL EQUIPMENT OR SYSTEM.

PERFORMANCE DATA

Performance data given in this document is provided as a guide for the user in determining suitability and does not constitute a warranty. It may represent the result of OMRON's test conditions, and the users must correlate it to actual application requirements. Actual performance is subject to the OMRON Warranty and Limitations of Liability.

CHANGE IN SPECIFICATIONS

Product specifications and accessories may be changed at any time based on improvements and other reasons.

It is our practice to change model numbers when published ratings or features are changed, or when significant construction changes are made. However, some specifications of the product may be changed without any notice. When in doubt, special model numbers may be assigned to fix or establish key specifications for your application on your request. Please consult with your OMRON representative at any time to confirm actual specifications of purchased products.

DIMENSIONS AND WEIGHTS

Dimensions and weights are nominal and are not to be used for manufacturing purposes, even when tolerances are shown.

ERRORS AND OMISSIONS

The information in this document has been carefully checked and is believed to be accurate; however, no responsibility is assumed for clerical, typographical, or proofreading errors, or omissions.

PROGRAMMABLE PRODUCTS

OMRON shall not be responsible for the user's programming of a programmable product, or any consequence thereof.

COPYRIGHT AND COPY PERMISSION

This document shall not be copied for sales or promotions without permission. This document is protected by copyright and is intended solely for use in conjunction with the product. Please notify us before copying or reproducing this document in any manner, for any other purpose. If copying or transmitting this document to another, please copy or transmit it in its entirety.

Safety Precautions

Alert Symbols for Safe Use

The following symbols are used in this manual to indicate precautions that must be observed to ensure safe use of the V680-HS51, V680-HS52, V680-HS63, V680-HS65, V680-HA63A, V680-D1KP52MT, V680-D1KP66T, V680-D1KP66MT, and V680-D1KP66T-SP. The precautions provided here contain important safety information. Be sure to observe these precautions.

The following signal words are used in this manual.



Indicates a potentially hazardous situation which, if not avoided, will result in minor or moderate injury, or may result in serious injury or death. Additionally, there may be significant property damage.

Meanings of Alert Symbols



Indicates general prohibitions for which there is no specific symbol.

Warning



These Products are not designed to be used either directly or indirectly in applications that detect human presence for the purpose of maintaining safety. Do not use these Products as a sensing means for protecting human lives.

Regulations and Standards

The Products conform to the following overseas regulations and standards.

1. The United States

	Amplifier	Antenna
This product complies with Part 15 Subpart C of the FCC Rules. FCC ID: E4E6CYSIDV6800406	V680-HA63A	V680-HS51 V680-HS52 V680-HS63 V680-HS65

FCC NOTICE

This device complies with part 15 of the FCC Rules. Operation is subject to the following two conditions:

- (1) This device may not cause harmful interference.
- (2) This device must accept any interference received, including interference that may cause undesired operation.

FCC WARNING

Changes or modifications not expressly approved by the party responsible for compliance could void the user's authority to operate the equipment.

Do not remove the ferrite core (TDK Type ZCAT1730-0730A:V680-HS52/-HS63/-HS65, TDK Type ZCAT1525-0430AP:V680-HS51) installed on the cables to suppress RF interference.

2. Europe

	Amplifier	Antenna
(Radio and Telecommunication Terminal Equipment Directive 1999/5/EC)	V680-HA63A	V680-HS51 V680-HS52 V680-HS63 V680-HS65
Radio: EN 300 330-2V1.3.1 (04-2006) EN 300 330-1V1.5.1 (04-2006)		
EMC: EN 301 489-3V1.4.1 (08-2002) EN 301 489-1V1.6.1 (09-2005)		
Safety: EN 61010-1: 2001 (2nd Edition)		



English	Hereby, Omron, declares that the RFID System, V680-HS51 Series, V680-HS52 Series, V680-HS63 Series, V680-HS65 Series and V680-HA63A Series are in compliance with the essential requirements and other relevant provisions of Directive 1999/5/EC.
Finnish	Omron vakuuttaa täten että RFID Säännös, V680-HS51 Series, V680-HS52 Series, V680-HS63 Series V680-HS65 Series,, V680-HA63A Series tyyppinen laite on direktiivin 1999/5/EY oleellisten vaatimusten ja sitä koskevien direktiivin muiden ehtojen mukainen.
Dutch	Hierbij verklaart Omron dat het toestel de RFID Systeem, V680-HS51 `Serie, V680-HS52 `Serie, V680-HS63 `Serie, V680-HS65 `Serie, V680-HA63A `Serie in overeenstemming is met de essentiële eisen en de andere relevante bepalingen van richtlijn 1999/5/EG.
French	Par la présente Omron déclare que la RFID Système, V680-HS51 Série, V680-HS52 Série, V680-HS63 Série, V680-HS65 Série, V680-HA63A Série sont conforme aux exigences essentielles et aux autres dispositions pertinentes de la directive 1999/5/CE.
Swedish	Härmed intygar Omron att den RFID System, V680-HS51 Serie, V680-HS52 Serie, V680-HS63 Serie, V680-HS65 Serie, V680-HA63A Serie står i överensstämmelse med de väsentliga egenskapskrav och övriga relevanta bestämmelser som framgår av direktiv 1999/5/EG.
Danish	Undertegnede Omron erklærer herved, at følgende den RFID System, V680-HS51 Serie, V680-HS52 Serie, V680-HS63 Serie, V680-HS65 Serie, 680-HA63A Serie overholder de væsentlige krav og øvrige relevante krav i direktiv 1999/5/EF.
German	Hiermit erklärt Omron, die RFID System, V680-HS51 Serie, V680-HS52 Serie, V680-HS63 Serie, V680-HS65 Serie, V680-HA63A Serie in Übereinstimmung mit den grundlegenden Anforderungen und den anderen relevanten Vorschriften der Richtlinie 1999/5/EG befindet. (BMW i)
Greek	ΜΕ ΤΗΝ ΠΑΡΟΥΣΑ Omron ΔΗΛΩΝΕΙ RFID ΟΥΣΙΑΣ, V680-HS51 ΟΕΙΡΑ, V680-HS52 ΟΕΙΡΑ, V680-HS63 ΟΕΙΡΑ, V680-HS65 ΟΕΙΡΑ, V680-HA63A ΟΕΙΡΑ ΣΥΜΜΟΡΦ ΟΝΕΤΑΙ ΠΡΟΣ ΤΙΣ ΟΥΣΙΟΛΟΓΙΚΕΣ ΑΠΑΙΤΗΣΕΙΣ ΚΑΙ ΤΙΣ ΛΟΙΠΕΣ ΣΧΕΤΙΚΕΣ ΔΙΑΤΑΞΕΙΣ ΤΗΣ ΟΔΗΓΙΑΣ 1999/5/ΕΚ.
Italian	Con la presente Omron dichiara che la RFID Sistema, V680-HS51Serie, V680-HS52Serie, V680-HS63 Serie, V680-HS65 Serie, V680-HA63A Serie sono conforme ai requisiti essenziali ed alle altre disposizioni pertinenti stabilite dalla direttiva 1999/5/CE.
Spanish	Por medio de la presente Omron declara que el RFID Sistema, V680-HS51 Serie, V680-HS52 Serie, V680-HS63 Serie, V680-HS65 Serie, V680-HA63A Serie esta conforme a los requisitos esenciales y cualesquiera otras disposiciones aplicables o exigibles de la Directiva 1999/5/CE.
Portuguese	Omron declara que a RFID Sistema, V680-HS51 Série, V680-HS52 Série, V680-HS63 Série, V680-HS65 Série, V680-HA63A Série ser conforme com os requisitos essenciais e outras disposições da Directiva 1999/5/CE.
Romanian	Prin prezenta, Omron declară că acest V680-HS51, V680-HS52, V680-HS63, V680-HS65, V680-HA63A este conform cu cerințele principale și cu celelalte prevederi relevante ale Directivei 1999/5/EC.

3. Japan

	Amplifier	Antenna
Equipment using high frequencies: Inductive Reading/Writing Communications Equipment Conforming standards: Inductive Reading/Writing Communications Equipment; Standard: ARIB STD-T82 EC-06019	V680-HA63A	V680-HS51 V680-HS52 V680-HS63 V680-HS65

4. Canada

	Amplifier	Antenna
IC ID:850J-V68HA63A	V680-HA63A	V680-HS51 V680-HS52 V680-HS63 V680-HS65

This device complies with RSS-Gen of IC Rules.

Operation is subject to the following two conditions:(1) this device may not cause harmful interference, and (2) this device must accept any interference received, including interference that may cause undesired operation.

5. China

	Amplifier	Antenna
CMII ID:2007DJ0577	V680-HA63A	V680-HS52-R
CMII ID:2007DJ0575	V680-HA63A	V680-HS52-W
CMII ID:2007DJ0573	V680-HA63A	V680-HS63-W
CMII ID:2007DJ0571	V680-HA63A	V680-HS63-R

1. 本产品的使用方法等请参见产品说明书。本产品的技术参数如下：

■使用频率为：13.553-13.567MHz

■所发射的电场强度在距设备10米处不得超过42dB μ A/m(采用准峰值检波)；

■频率容限： $\leq 100 \times 10^{-6}$

■杂散辐射等其他技术指标请参照2005/423号文件

2. 使用者不得擅自更改发射频率、加大发射功率(包括额外加装射频功率放大器)，不得擅自外接天线或改用其它发射天线；

3. 使用时应注意不得对各种合法的无线电电信业务产生有害干扰；一旦发现有干扰现象时，应立即停止使用，并采取措施消除干扰后方可继续使用；

4. 本产品为微功率无线电设备，能够承受各种无线电业务的干扰或工业、科学及医疗应用设备的辐射干扰；

5. 本产品不得在飞机和机场附近使用。

6. Korea

	Amplifier	Antenna
OMR-V680-HA63A	V680-HA63A	V680-HS52-R V680-HS52-W V680-HS63-R V680-HS63-W V680-HS65-R V680-HS65-W

급 기기 (가정용 정보통신기기)

이 기기는 가정용으로 전자파적합등록을 한 기기로서 주거지역에서는 물론 모든 지역에서 사용할 수 있습니다.

7. Taiwan

	Amplifier	Antenna
CCAB07LP1220T4	V680-HA63A	V680-HS52 V680-HS63 V680-HS65

低功率電波輻射性電機管理辦法

第十二條

經型式認證合格之低功率射頻電機，非經許可，公司、商號或使用者均不得擅自變更頻率、加大功率或變更原設計之特性及功能。

第十四條

低功率射頻電機之使用不得影響飛航安全及干擾合法通信；經發現有干擾現象時，應立即停用，並改善至無干擾時方得繼續使用。

前項合法通信，指依電信法規定作業之無線電通信。

低功率射頻電機須忍受合法通信或工業、科學及醫療用電波輻射性電機設備之干擾。

8. Hong Kong

	Amplifier	Antenna
LP407043	V680-HA63A	V680-HS52 V680-HS63

9. Singapore

	Amplifier	Antenna
S0294-07	V680-HA63A	V680-HS52 V680-HS63 V680-HS65

10. Malaysia

	Amplifier	Antenna
A011579	V680-HA63A	V680-HS52 V680-HS63 V680-HS65

If the product is used in Malaysia, a label must be attached on-site to the side of the V680-HA63A. Please consult your OMRON sales representative for details.

11. Philippine

	Amplifier	Antenna
ESD-0702996C	V680-HA63A	V680-HS52 V680-HS63 V680-HS65

12. Mexico

	Amplifier	Antenna
COFETEL:RCPOMV607-622	V680-HA63A	V680-HS52 V680-HS63

Este equipo opera a título secundario, consecuentemente, debe aceptar interferencias perjudiciales incluyendo equipos de la misma clase y puede no causar interferencias a sistemas operando a título primario.

13. Thailand

The certification is unnecessary, so the product can be used.

Changes or modifications not expressly approved by the party responsible for compliance could void the user's authority to operate the equipment.

Do not remove the ferrite core (TDK Type ZCAT1730-0730A:V680-HS52/-HS63/-HS65, TDK Type ZCAT1525-0430AP:V680-HS51) installed on the cables to suppress RF interference.

Precautions for Safe Use

Be sure to observe the following precautions to ensure safe use of the Products.

1. Do not use the Products in environments with flammable, explosive, or corrosive gasses.
2. Do not attempt to disassemble, repair, or modify any Product.
3. Tighten mounting screws securely.
4. Because a cable has a locking mechanism, make sure that it has been locked before using the cable.
5. Do not allow water or pieces of wire to enter from openings in the case. Doing so may cause fire or electric shock.
6. Turn OFF the Controller power supply before mounting or removing an Antenna or Amplifier.
7. If an error is detected in any Product, immediately stop operation and turn OFF the power supply. Consult with an OMRON representative.
8. Dispose of the Products as industrial waste.
9. Observe all warnings and precautions given in the body of this manual.
10. Do not touch the product immediately after usage at high temperatures. Doing so may occasionally result in burning.

Precautions for Correct Use

Always observe the following precautions to prevent operation failures, malfunctions, and adverse effects on performance and equipment.

1. Installation Environment

Do not use the Products in the following locations.

- Locations exposed to corrosive gases, dust, metallic powder, or salts
- Locations not within the specified operating temperature range
- Locations subject to rapid changes in temperature or condensation
- Locations not within the specified humidity range
- Locations subject to direct vibration or shock outside the specified ranges
- Locations subject to spray of water, oil, or chemicals

2. Installation

The Products communicate with Tags using the 13.56-MHz frequency band. Some motors, inverters, and switching power supplies generate noise that can affect communications with the Tags and cause errors. If such devices are located near the Tags, always test operation in advance to confirm whether the system will be affected.

- Observe the following precautions to minimize the effects of normal noise.
 - (1) Ground all metal objects in the vicinity of the Products to 100 Ω or less.
 - (2) Do not use the Products near high-voltage or high-current lines.
- Do not use non-waterproof Products in an environment where mist is present.
- Do not expose the Products to chemicals that adversely affect the Product materials.
- When mounting the Products, tighten the screws to the following torques.
 - V680-HS51: 6 N·m
 - V680-HS52: 40 N·m
 - V680-HS63: 1.2 N·m
 - V680-HS65: 1.2 N·m
- Do not pull the Antenna connector over the power of 30 N.

The Antenna connector may be broken.
- Transmission will not be possible if the front and back panels are mistakenly reversed and the Unit is mounted to a metallic surface.
 - V680-D1KP66MT
- The transmission distance will be reduced when the Unit is not mounted to a metallic surface.
 - V680-D1KP66MT
- If multiple Antennas are mounted near each other, communications performance may decrease due to mutual interference. Refer to *Installing Antennas on page 48* and check to make sure there is no mutual interference.
- Depending on the operating environment, the case surface may become fogged, but basic performance will not be affected.

3. Storage

Do not store the Products in the following locations.

- Locations exposed to corrosive gases, dust, metallic powder, or salts
- Locations not within the specified storage temperature range
- Locations subject to rapid changes in temperature or condensation
- Locations not within the specified storage humidity range
- Locations subject to direct vibration or shock outside the specified ranges
- Locations subject to spray of water, oil, or chemicals

4. Cleaning

- Do not clean the Products with paint thinner or the equivalent. Paint thinner or the equivalent will dissolve the resin materials and case coating.

5. Combination of the Amplifier

- Use the V680-D1KP52MT, V680-D1KP66T, V680-D1KP66MT, and V680-D1KP66T-SP ID Tags in combination with only the V680-HA63A Amplifier. Do not use these ID Tags together with the V680-HA63B Amplifier.

Meanings of Symbols



Indicates particularly important points related to a function, including precautions and application advice.



Indicates page numbers containing relevant information.

Table of Contents

Safety Precautions	3
Regulations and Standards	3
Precautions for Safe Use	7
Precautions for Correct Use	8
Meanings of Symbols	10
Table of Contents	11
Section 1 Product Overview	13
Features	14
Product Configuration	15
Section 2 Specifications and Performance	17
Antennas with Separate Amplifier	18
Amplifier	25
Tags	28
Section 3 Communications Specifications	35
Communications Distances	36
Communication Time (Reference)	44
Section 4 Installation	47
Installing Antennas	48
Mounting Amplifiers	54
Installing Tags	56
Section 5 Chemical Resistance	65
Chemical Resistance of the Antennas	66
Chemical Resistance of Tags	67
Degree of Protection	72
Revision History	74

MEMO

Section 1

Product Overview

▣ Features	14
▣ Product Configuration	15

Features

The V680-series RFID System actively supports many different types of system, such as distributed-control systems and many-product, small-lot production systems, with non-contact data communications using electromagnetic induction.

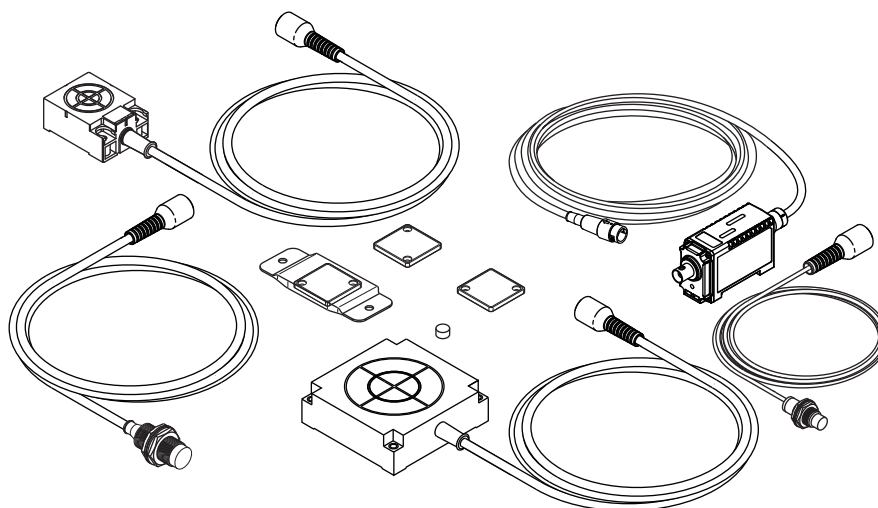

■ Non-contact Data Communications

The V680 Series uses electromagnetic induction to enable non-contact, bi-directional data communications between Antennas and Tags.

■ EEPROM Memory

EEPROM (non-volatile memory) is used for Tag memory. No battery is required, so there is no need to be concerned about battery service life.

■ CRC Used for Transmission Error Detection

A bi-directional 16-bit CRC (Cyclic Redundancy Check) has been added as the error detection method for wire transmissions between ID Controllers and Antennas, and for wireless transmissions between Antennas and Tags. This method maintains superior communications reliability even where problems such as noise occur.

■ 1,000byte of Memory

Tags have 1,000byte of memory. In addition to the ID data required on-site, data such as model numbers and inspection information can be input.

■ Long Service Life of 100,000 Data Rewrites at Normal Temperatures

When the Tag is used at temperatures of up to 25°C, each block of EEPROM data can be rewritten up to 100,000 times.

■ Superior Environmental Resistance and High Reliability

Antennas and Tags now have greater environmental resistance and are not affected by vibration, oil, or water (in units of single, 8-byte blocks).

Product Configuration

A V680-series RFID System consists of an ID Controller, one or more Amplifiers, one or two Antennas, and Tags. Select the models suitable for the application.

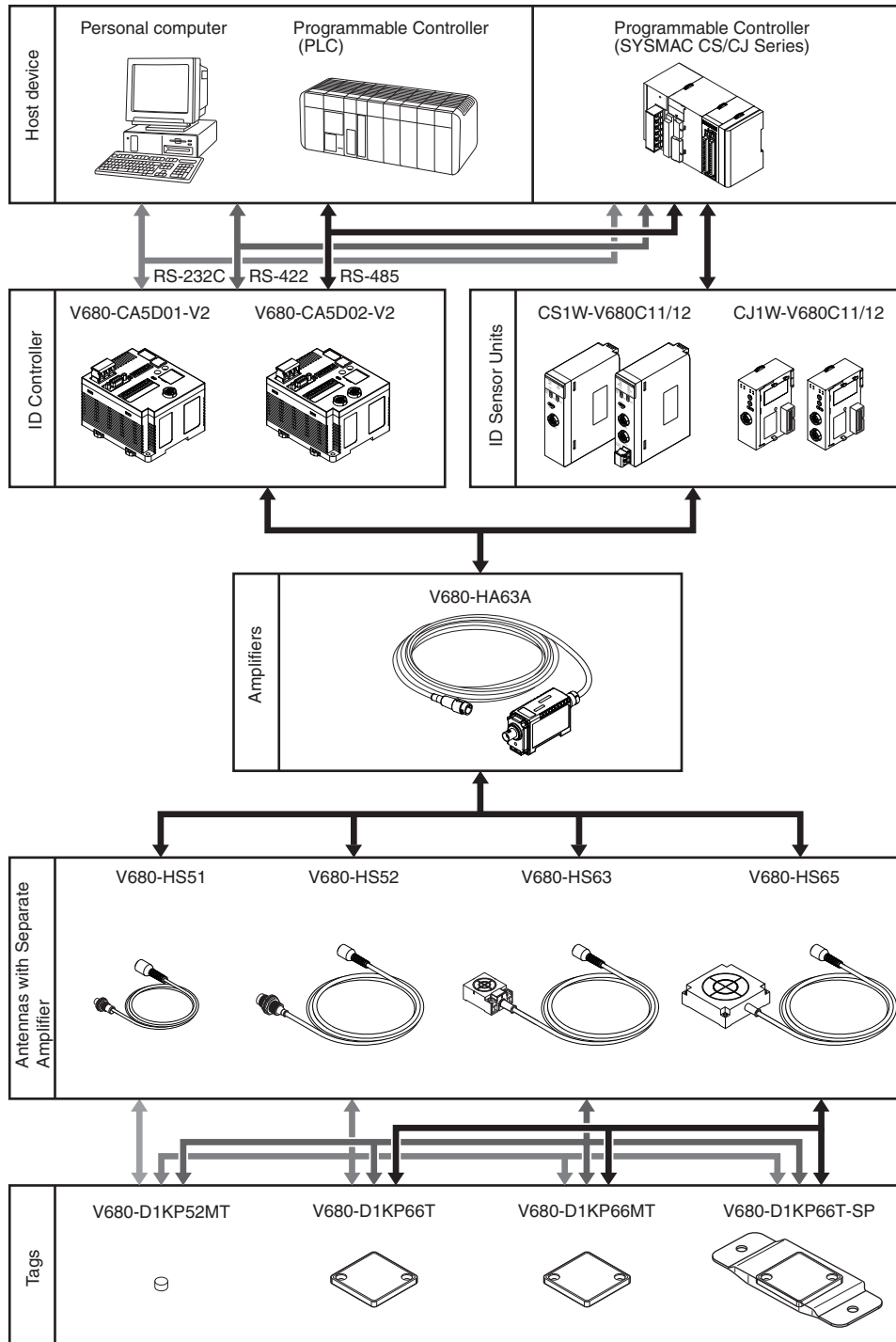

 When embedding the V680-D1KP52MT into a metal surface, use the V680-HS51, V680-HS52 Antenna. Transmission will not be possible if the V680-HS63 Antenna is used.

CHECK!

 Use the V680-D1KP52MT, V680-D1KP66T, V680-D1KP66MT, and V680-D1KP66T-SP ID Tags in combination with only the V680-HA63A Amplifier. Do not use these ID Tags together with the V680-HA63B Amplifier.

CHECK!

MEMO

Section 2

Specifications and Performance

☒ Antennas with Separate Amplifier	18
☒ Amplifier	25
☒ Tags	28

Antennas with Separate Amplifier

V680-HS51

General Specifications

Item	Model	V680-HS51
Ambient operating temperature		-10 to 60°C (with no icing)
Ambient storage temperature		-25 to 75°C (with no icing)
Ambient operating humidity		35% to 95% (with no condensation)
Insulation resistance		20 MΩ min. (at 500 VDC) between connector terminals and case
Dielectric strength		1,000 VAC, 50/60 Hz for 1 min between connector terminals and case
Degree of protection		IP67.(IEC60529) In-house standard for antenna oil resistance (former JEM standard equivalent to IP67g) Note: The connectors are not waterproof.
Dielectric strength		10 to 2,000 Hz, 1.5-mm double amplitude, acceleration: 150 m/s ² , 10 sweeps in each of 3 axis directions (up/down, left/right, and forward/backward) for 15 minutes each
Shock resistance		1,000 m/s ² , 3 times each in 6 directions (Total: 18 times)
Dimensions		M12 × 35 mm
Material		ABS resin, brass, and epoxy resin filler
Weight		Approx. 55 g
Cable length		Standard lengths of 2 m

Dimensions

V680-HS51

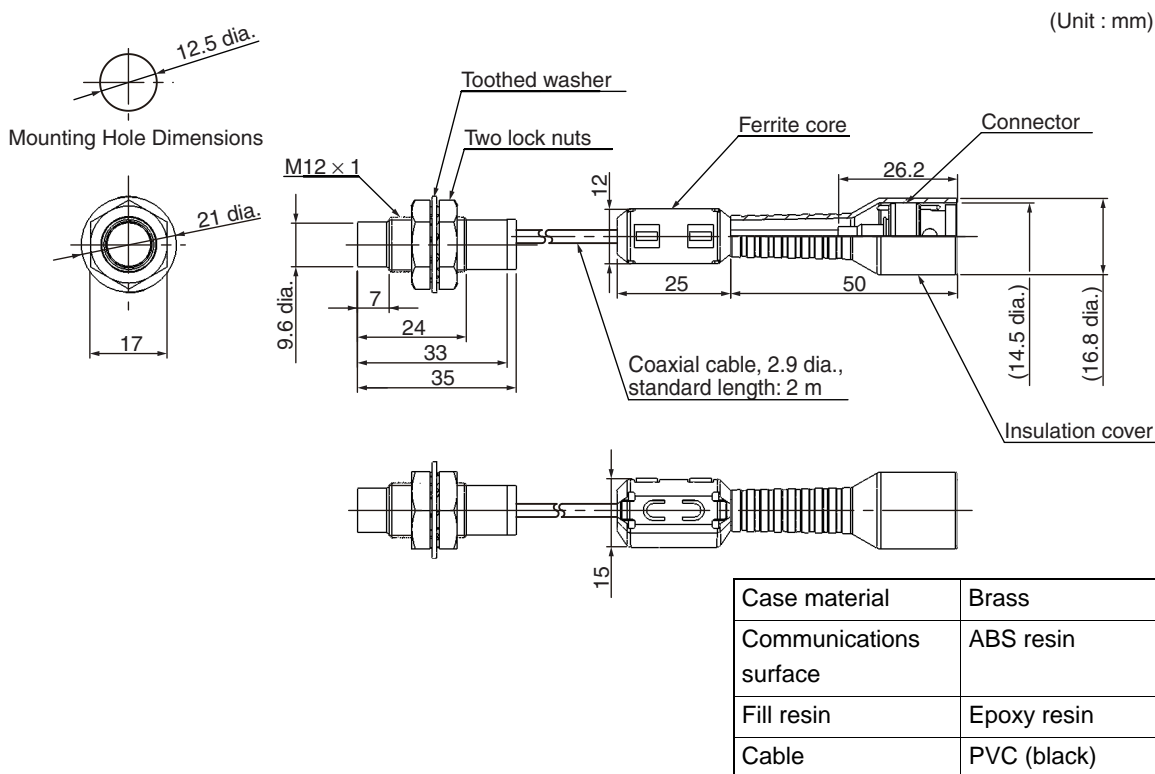

V680-HS52

General Specifications

Item	Model	V680-HS52-W (Standard cable, waterproof connector)	V680-HS52-R (Flexible cable, non-waterproof connector)
Ambient operating temperature		-10 to 60°C (with no icing)	
Ambient storage temperature		-25 to 75°C (with no icing)	
Ambient operating humidity		35% to 95% (with no condensation)	
Insulation resistance		20 MΩ min. (at 500 VDC) between connector terminals and case	
Dielectric strength		1,000 VAC, 50/60 Hz for 1 min between connector terminals and case	
Degree of protection		IP67.(IEC60529) In-house standard for antenna oil resistance (former JEM standard equivalent to IP67g) Note: The connector specifications are IP67 and IP65.(IEC60529)	IP67.(IEC60529) In-house standard for antenna oil resistance (former JEM standard equivalent to IP67g) Note: The connectors are not waterproof.
Dielectric strength		10 to 500 Hz, 1.5-mm double amplitude, acceleration: 100 m/s ² , 10 sweeps in each of 3 axis directions (up/down, left/right, and forward/backward) for 8 minutes each	
Shock resistance		500 m/s ² , 3 times each in 6 directions (Total: 18 times)	
Dimensions		M22 × 65 mm	
Material		ABS resin, brass, and epoxy resin filler	
Weight		Approx. 850 g (with 12.5 m cable)	
Cable length		Standard lengths of 2 and 12.5 m	

Dimensions

• V680-HS52-W

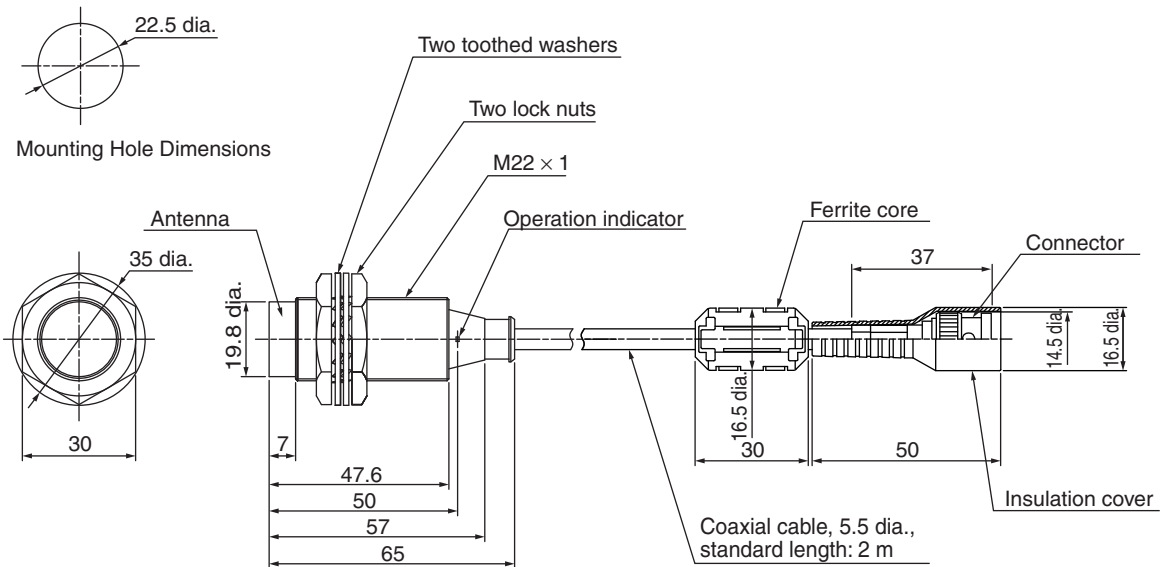

Case material	Brass
Communications surface	ABS resin
Fill resin	Epoxy resin
Cable	PVC (gray)

• V680-HS52-R

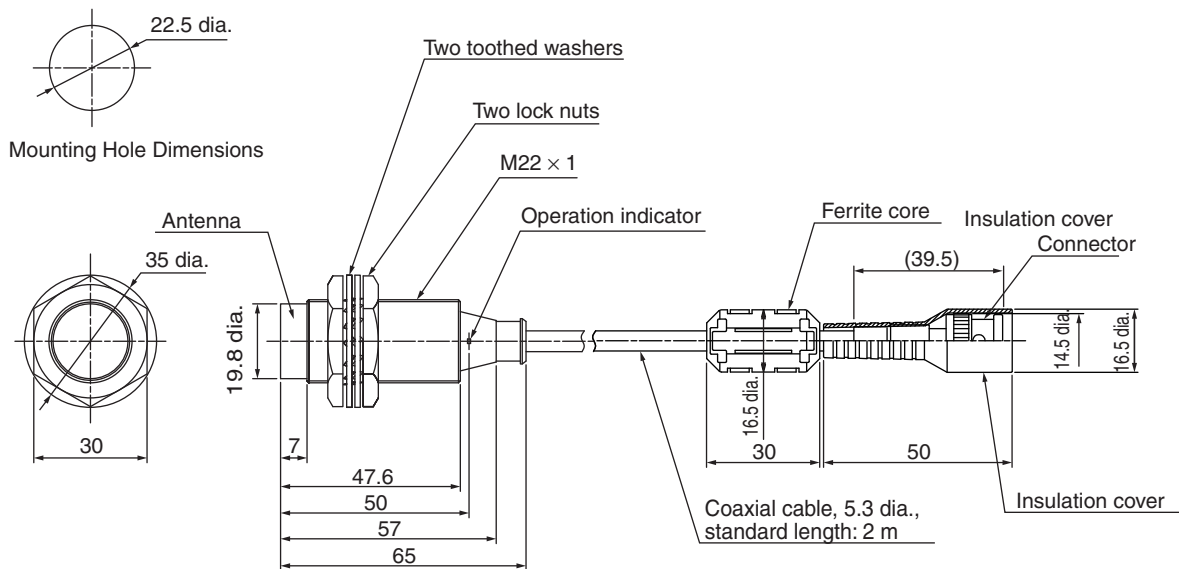

Case material	Brass
Communications surface	ABS resin
Fill resin	Epoxy resin
Cable	PVC (black)

V680-HS63

General Specifications

Item	Model	V680-HS63-W (Standard cable, waterproof connector)	V680-HS63-R (Flexible cable, non-waterproof connector)
Ambient operating temperature		-10 to 60°C (with no icing)	
Ambient storage temperature		-25 to 75°C (with no icing)	
Ambient operating humidity		35% to 95% (with no condensation)	
Insulation resistance		20 MΩ min. (at 500 VDC) between cable terminals and case	
Dielectric strength		1,000 VAC, 50/60Hz for 1 min between cable terminals and case	
Degree of protection		IP67.(IEC60529) In-house standard for antenna oil resistance (former JEM standard equivalent to IP67g) Note: The connector specifications are IP67 and IP65.(IEC60529)	IP67.(IEC60529) In-house standard for antenna oil resistance (former JEM standard equivalent to IP67g) Note: The connectors are not waterproof.
Vibration resistance		10 to 500 Hz, 1.5-mm double amplitude, acceleration: 100 m/s ² , 10 sweeps in each of 3 axis directions (up/down, left/right, and forward/backward) for 11 minutes each	
Shock resistance		500 m/s ² , 3 times each in 6 directions (Total: 18 times)	
Dimensions		40 × 53 × 23 mm	
Material		ABS resin case, epoxy resin filler	
Weight		Approx. 850 g (with 12.5 m cable)	
Cable length		Standard lengths of 2 and 12.5 m	

Dimensions

• V680-HS63-W

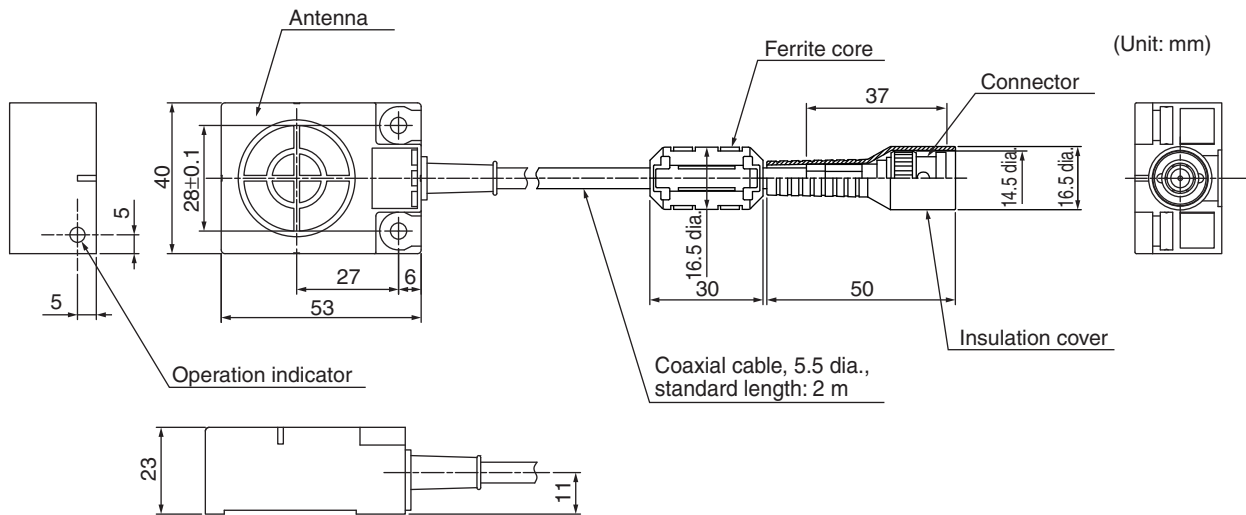

Note: Mounting Hole Dimensions

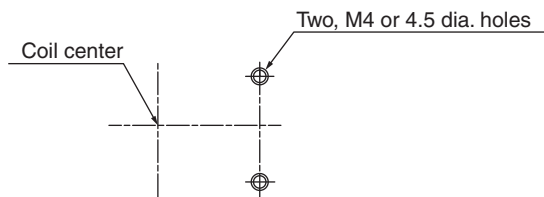

Case material	ABS resin
Fill resin	Epoxy resin
Cable	PVC (gray)

V680-HS63-R

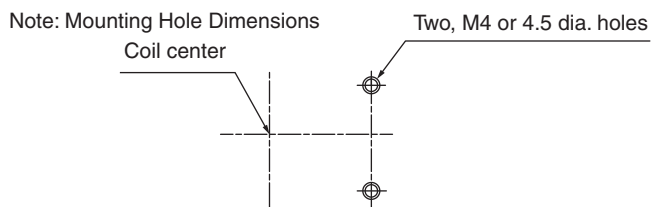
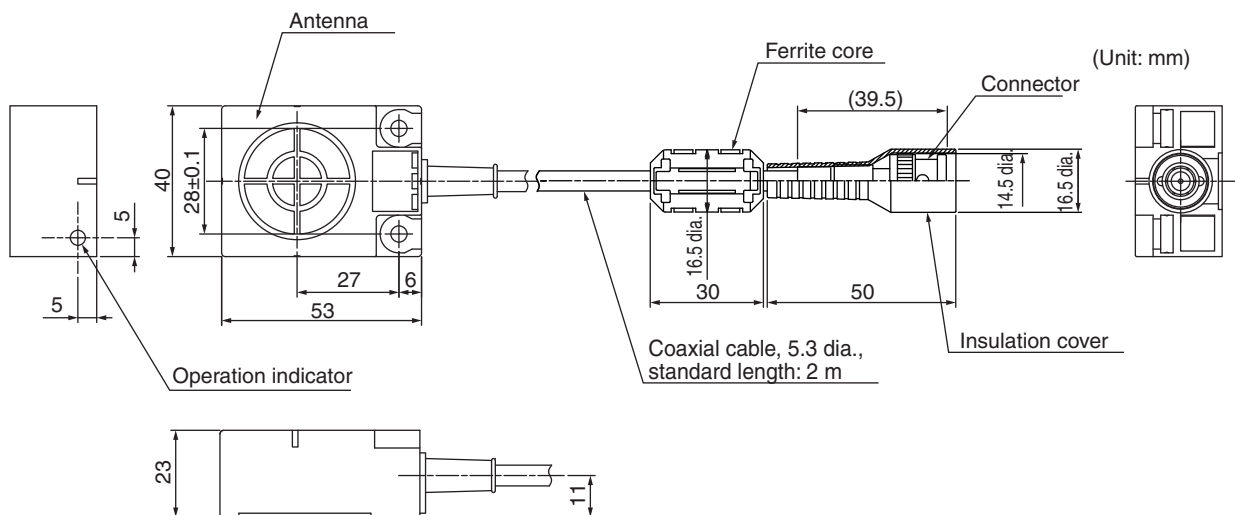

Case material	ABS resin
Fill resin	Epoxy resin
Cable	PVC (black)

V680-HS65

General Specifications

Item	Model	V680-HS65-W (Standard cable, waterproof connector)	V680-HS65-R (Flexible cable, non-waterproof connector)
Ambient operating temperature		-25 to 70°C (with no icing)	
Ambient storage temperature		-40 to 85°C (with no icing)	
Ambient operating humidity		35% to 95% (with no condensation)	
Insulation resistance		20 MΩ min. (at 500 VDC) between connector terminals and case	
Dielectric strength		1,000 VAC, 50/60 Hz for 1 min between connector terminals and case	
Degree of protection		IP67 (IEC60529) In-house standard for antenna oil resistance (former JEM standard equivalent to IP67g) Note: The connector specifications are IP67 and IP65 (IEC 60529).	IP67 (IEC60529) In-house standard for antenna oil resistance (former JEM standard equivalent to IP67g) Note: The connectors are not waterproof.
Dielectric strength		10 to 500 Hz, 1.5-mm double amplitude, acceleration: 100 m/s ² , 10 sweeps in each of 3 axis directions (up/down, left/right, and forward/backward) for 11 minutes each	
Shock resistance		500 m/s ² , 3 times each in 6 directions (Total: 18 times)	
Dimensions		100 × 100 × 30 mm	
Material		ABS resin case, epoxy resin filler	
Weight		Approx. 1100 g (with 12.5 m cable)	
Cable length		Standard lengths of 2 and 12.5 m	

Dimensions

V680-HS65-W

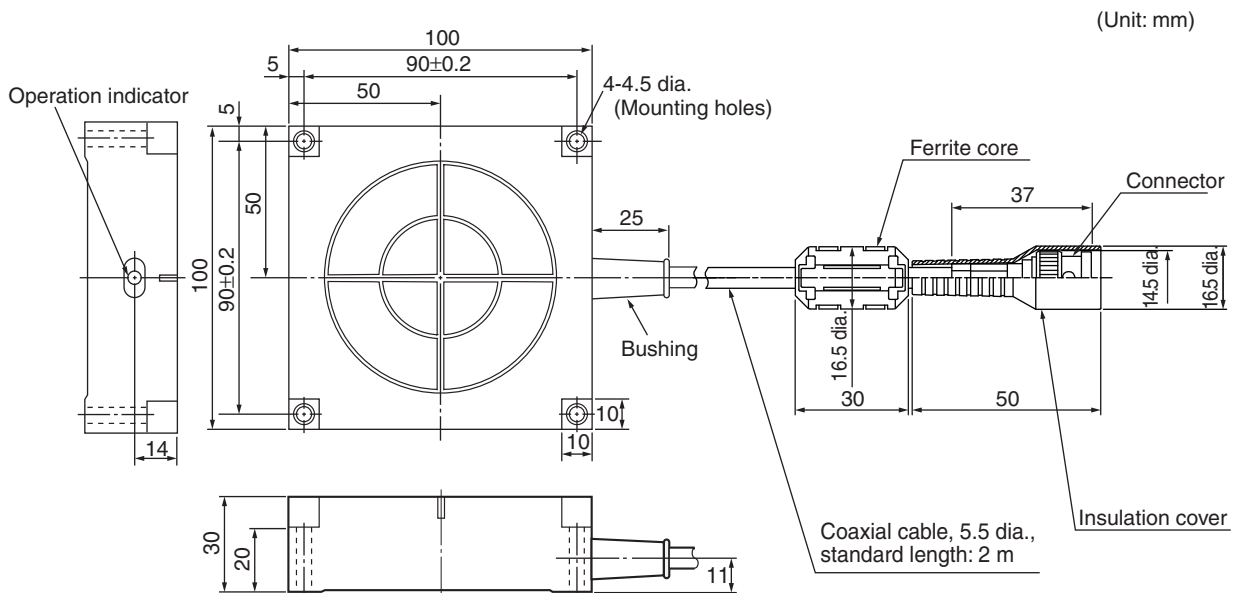

Case material	ABS resin
Fill resin	Epoxy resin
Cable	PVC (gray)

V680-HS65-R

(Unit: mm)

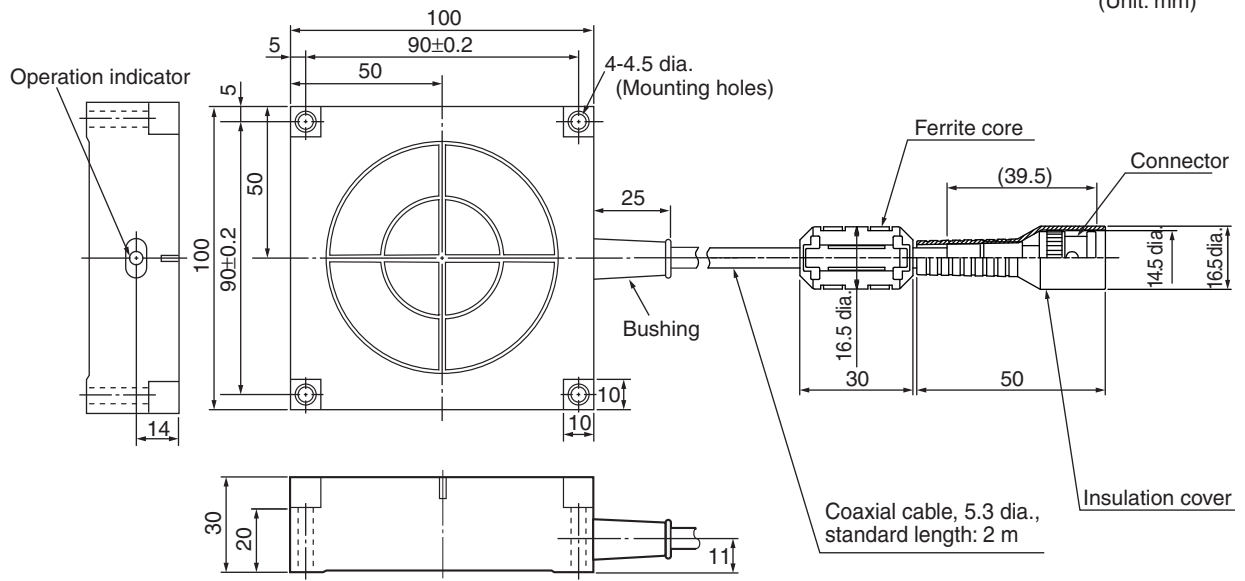

Case material	ABS resin
Fill resin	Epoxy resin
Cable	PVC (black)

Amplifier

V680-HA63A

General Specifications

Item	Model	V680-HA63A
Ambient operating temperature		-10 to 55°C (with no icing)
Ambient storage temperature		-25 to 65°C (with no icing)
Ambient operating humidity		35% to 85% (with no condensation)
Insulation resistance		20 MΩ min. (at 500 VDC) between cable terminals and case
Dielectric strength		1,000 VAC, 50/60 Hz for 1 minute between cable terminals and case.
Degree of protection	IP67, IP65 (IEC 60529)	IP40 (IEC 60529) <i>Note:</i> Not including connector at Controller end. (When V680-HS52-W, V680-HS63-W, and V680-HS65-W is connected)
Dielectric strength		10 to 500 Hz, 1.5-mm double amplitude, acceleration:100 m/s ² , 10 sweeps in each of 3 axis directions (up/down, left/right, and forward/backward) for 11 minutes each
Shock resistance		500 m/s ² , 3 times each in 6 directions (Total: 18 times)
Dimensions		25 × 40 × 65 mm (Not including protrusions.)
Materials		PC
Weight		Approx. 650 g (with 10 m cable)
Cable length		Standard lengths of 5 and 10 m

Note: The maximum total cable extension is 50 m (including the Amplifier cable). A maximum of two extension cables can be connected.

Dimensions

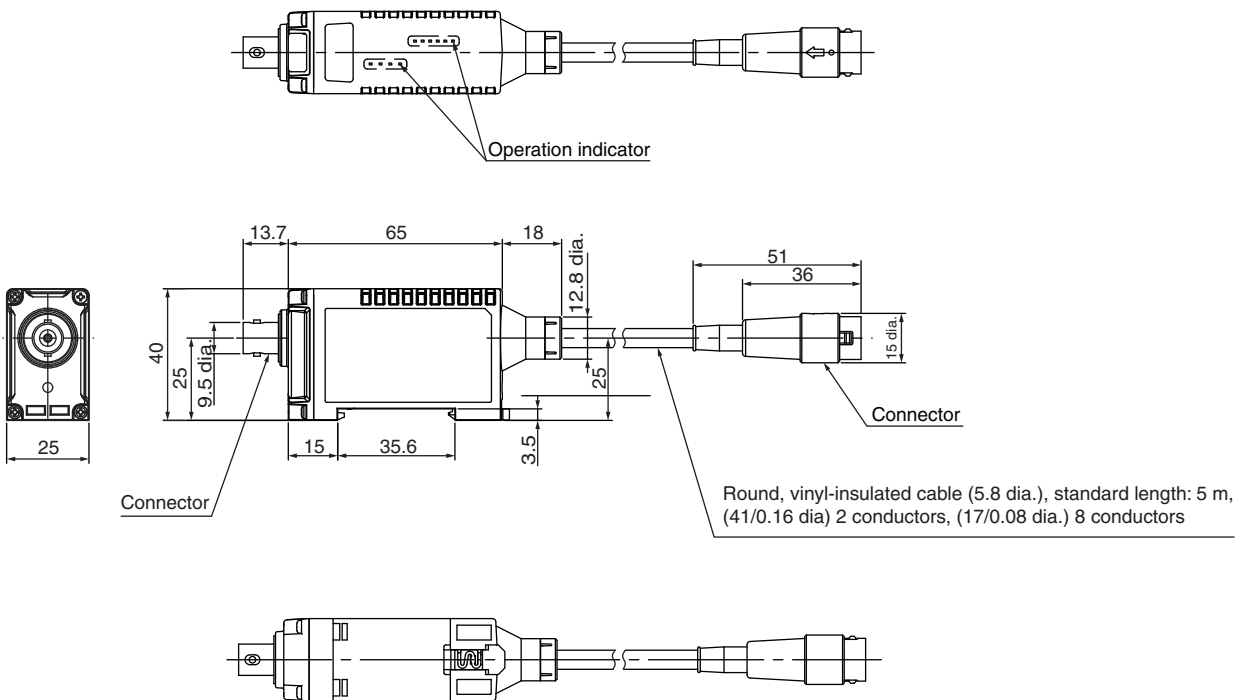

Case material	PC resin
Cable	PVC

Nomenclature

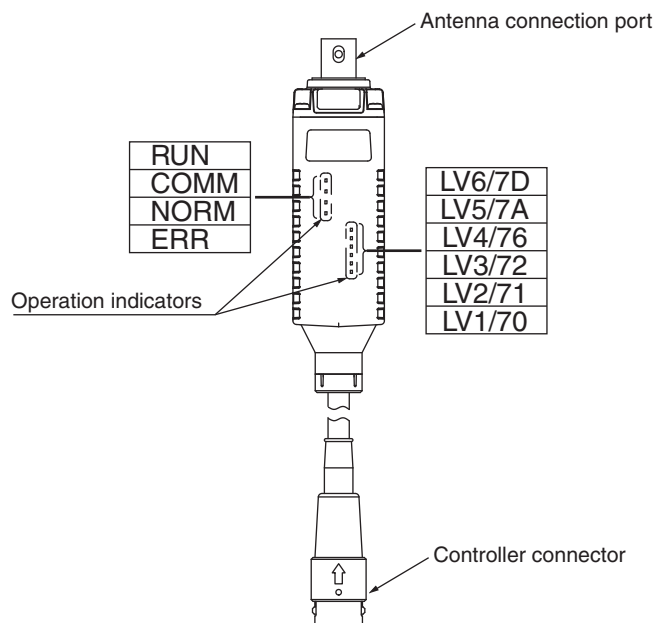

■ Antenna Connection Port

The Antenna connection port is connected a V680-series Antenna.

■ Controller Connector

The Controller connector is connected to Antenna connection port on the Controller.

■ Operation Indicators (LEDs)

Name	Color	Meaning
RUN	Green	Lit when the power is ON.
COMM	Yellow	Lit when a command is being sent.
NORM	Green	Lit when communications with a Tag are normal in Normal Communications Mode.
ERR	Red	Lit when an error occurs in communications with a Tag in Normal Communications Mode.
LV6/7D	Yellow	Maintenance Mode: Lit at distance or speed level 6. Normal Communications Mode: Lit when a write protection error occurs.
LV5/7A	Yellow	Maintenance Mode: Lit at distance or speed level 5 or higher. Normal Communications Mode: Lit when an address error occurs.
LV4/76	Yellow	Maintenance Mode: Lit at distance or speed level 4 or higher. Normal Communications Mode: Lit when a Tag memory error occurs.
LV3/72	Yellow	Maintenance Mode: Lit at distance or speed level 3 or higher. Normal Communications Mode: Lit when a no Tag error occurs.
LV2/71	Yellow	Maintenance Mode: Lit at distance or speed level 2 or higher. Normal Communications Mode: Lit when a verification error occurs.
LV1/70	Yellow	Maintenance Mode: Lit at distance or speed level 1 or higher. Normal Communications Mode: Lit when a Tag communications error occurs.



The distance level will vary greatly depending on the surrounding environment. The setting position will serve as a guide, but use RUN mode to conduct a sufficient number of tests in the actual operating environment. Values of distance level 4 or above may not be displayed, but this will not affect the RUN mode performance and does not indicate a malfunction.

Cables

Specifications

Item	Model	V700-A43/V700-A44
Number of conductors		10
Insulation resistance		5 MΩ min. (at 500 VDC) between terminals and sheath
Dielectric strength		500 VAC, 1 min

Dimensions

Item	Model	V700-A43	V700-A44
Length (L1)		Approx. 10m	Approx. 20 m
Weight		Approx. 700 g	Approx. 1,350 g

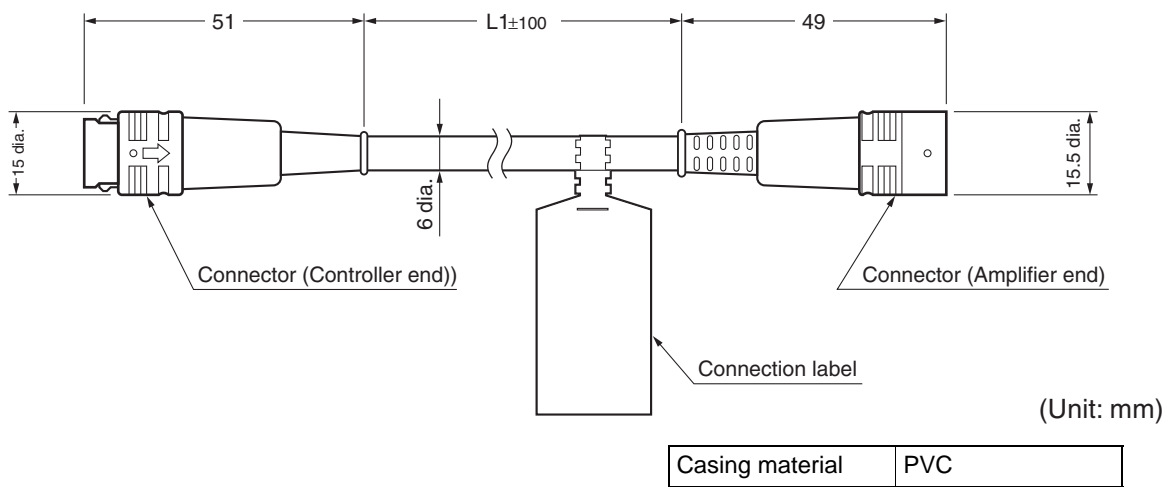

Tags

Specifications and Dimensions

■ V680-D1KP52MT

• General Specifications

Item	Model	V680-D1KP52MT
Memory capacity		1,000 bytes (user area)
Memory type		EEPROM
Data backup time		10 years after writing (85°C or less), 0.5 years after writing (85°C to 125°C) Total data backup time at high temperatures exceeding 125°C is 10 hours (See note.)
Memory longevity		100,000 times per block (25°C)
Ambient operating temperature when communicating		-25 to 85°C (with no icing)
Ambient operating temperature when not communicating		-40 to 125°C (with no icing)
Ambient storage temperature		-40 to 125°C (with no icing)
Ambient operating humidity		35% to 95%
Degree of protection		IP68 (IEC 60529) In-house standard for antenna oil resistance (former JEM standard equivalent to IP67g)
Vibration resistance		10 to 2,000 Hz, 1.5-mm double amplitude, acceleration: 150 m/s ² , 10 sweeps each in X, Y, and Z directions for 15 minutes each
Shock resistance		500 m/s ² , 3 times each in X, Y, and Z directions (Total: 18 times)
Dimensions		8 dia. × 5 mm
Materials		Case: PPS resin, Fill resin: Epoxy resin
Weight		Approx. 0.5 g
Metal countermeasures		Yes

Note: After string data at high temperatures, rewrite the data even if changes are not required, In this manual, high temperatures are those exceeding 125°C up to 180°C.

• Dimensions

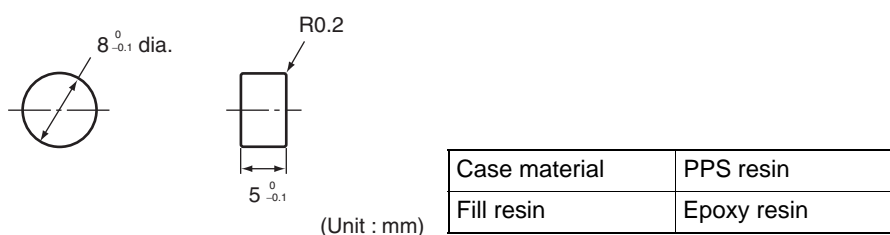

When embedding the V680-D1KP52MT into a metal surface, use the V680-HS51, V680-HS52 Antenna. Transmission will not be possible if the V680-HS63 Antenna is used.



The side with the markings is the communications surface. Mount the Tag with this side facing the Antenna.



The ID code is written in the memory of the Tag and may be affected by data retention characteristics at high temperatures. Take suitable precautions when using the READ ID command for Tags operating at high temperatures.

■ V680-D1KP66T/66MT

• General Specifications

Item	Model	V680-D1KP66T	V680-D1KP66MT
Memory capacity		1,000 bytes (user area)	
Memory type		EEPROM	
Data backup time		10 years after writing (85°C or less), 0.5 years after writing (85°C to 125°C) Total data backup time at high temperatures exceeding 125°C is 10 hours (See note.)	
Memory longevity		100,000 times per block (25°C)	
Ambient operating temperature when communicating		-25 to 85°C (with no icing)	
Ambient operating temperature when not communicating		-40 to 125°C (with no icing)	
Ambient storage temperature		-40 to 125°C (with no icing)	
Ambient operating humidity		35% to 95%	
Degree of protection		IP68 (IEC 60529) In-house standard for antenna oil resistance (former JEM standard equivalent to IP67g)	
Vibration resistance		10 to 2,000 Hz, 1.5-mm double amplitude, acceleration: 150 m/s ² , 10 sweeps each in X, Y, and Z directions for 15 minutes each	
Shock resistance		500 m/s ² , 3 times each in X, Y, and Z directions (Total: 18 times)	
Dimensions		34 × 34 × 3.5 mm	
Materials		Case: PPS resin	
Weight		Approx. 6 g	Approx. 7.5 g
Metal countermeasures		None	Yes

Note: After string data at high temperatures, rewrite the data even if changes are not required, In this manual, high temperatures are those exceeding 125°C up to 180°C.

The V680-D1KP66MT is designed to be mounted directly to metal. The V680-D1KP66T and V680-D1KP66MT markings are shown in the following diagrams.

● V680-D1KP66MT



● V680-D1KP66T

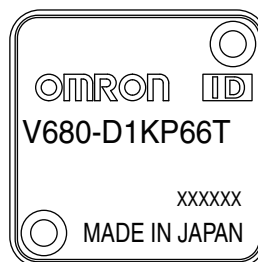

The side with the markings is the communications surface. Mount the Tag with this side facing the Antenna.



The ID code is written in the memory of the Tag and may be affected by data retention characteristics at high temperatures. Take suitable precautions when using the READ ID command for Tags operating at high temperatures.

• Dimensions

V680-D1KP66T/66MT

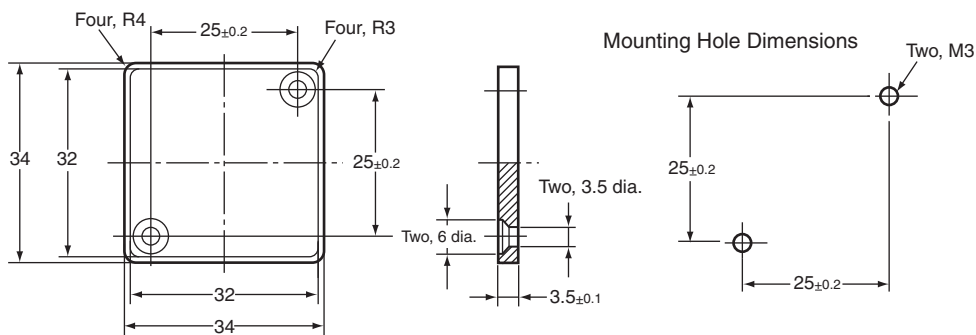

Case material	PPS resin
---------------	-----------

V600-A86 Attachment

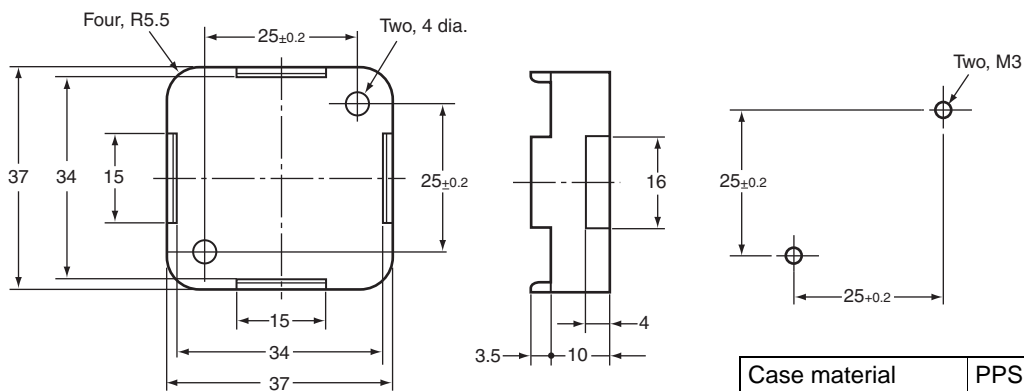

Case material	PPS resin
---------------	-----------

Tag Heat Resistivity

- Storing Tags under high temperatures will adversely affect the performance of the internal parts and the service life of the Tags.
- An LTPD of 10% was determined during the evaluation for Tags that reached the end of their life after testing under the following test conditions.

Heat cycle	-10°C/+150°C, 30 minutes each for 1,000 cycles
	-100°C/+180°C, 30 minutes each for 200 cycles
High temperatures	+150°C, 1,000 hours
	+180°C, 200 hours



LTPD: Lot tolerance percent defective

The lower limit of the malfunction rate for lots to be considered unacceptable during reliability testing.

■ V680-D1KP66T-SP

• General Specifications

Item	Model	V680-D1KP66T-SP
Memory capacity		1,000 bytes (user area)
Memory type		EEPROM
Data backup time		10 years after writing (85°C or less)
Memory longevity		100,000 times per block (25°C)
Ambient operating temperature when communicating		-25 to 70°C (with no icing)
Ambient operating temperature when not communicating		-40 to 110°C (with no icing)
Ambient storage temperature		-40 to 110°C (with no icing)
Ambient operating humidity		35% to 95%
Degree of protection		IP67
Vibration resistance		10 to 2,000 Hz, 1.5-mm double amplitude, acceleration: 150 m/s ² , 10 sweeps each in X, Y, and Z directions for 15 minutes each
Shock resistance		500 m/s ² , 3 times each in X, Y, and Z directions (Total: 18 times)
Dimensions		95 × 36.5 × 6.5 mm (excluding protruding parts)
Materials		External coating: Fluororesin (PFA) Tag body: PPS resin
Weight		Approx. 20 g
Mounting method		Two M5 screws
Metal countermeasures		None

• Dimensions

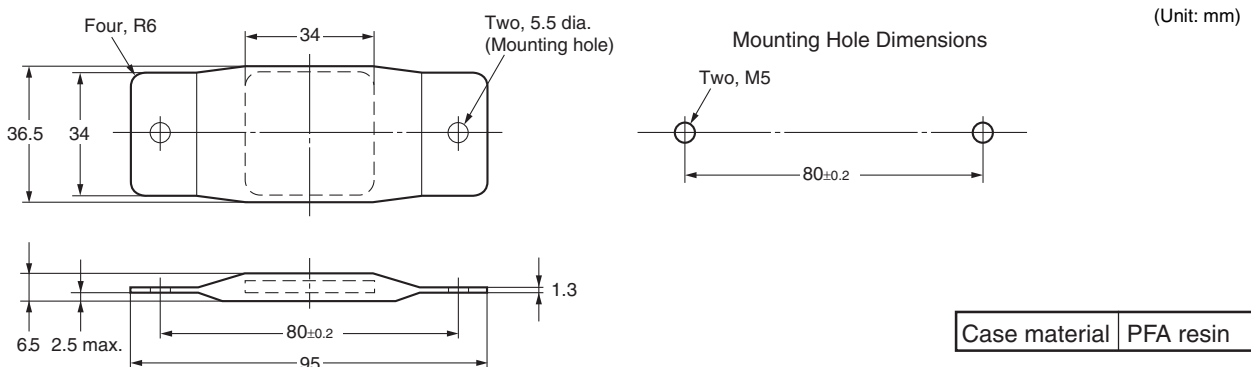

The side with the markings is the communications surface. Mount the Tag with this side facing the Antenna.

Memory Map

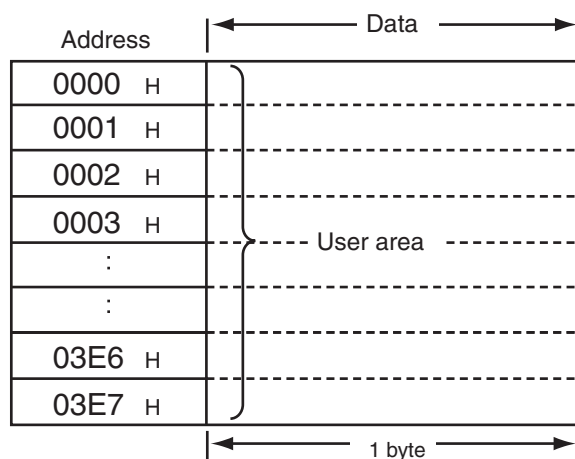

EEPROM is used as memory in the Tags.

The memory capacity available to the user is 1,000 bytes, including 0000H to 0003H (the Write Protection Setting Area).



The access to the memory is executed at every block.
1 block is 8 bytes (8 addresses).

CHECK!

Write Protection Function

The write protection function prevents important data, such as product information, stored in memory in a Tag from being inadvertently overwritten.

After important data has been written to memory, it can be write-protected using the following method.



CHECK!

The write protect function setting can be switched with switches 4 to 7 (Write Protect Function Setting) of the V680-CA5D□□-V2 Controller.

Setting the Write Protection Function

Write protection is set in Tag addresses 0000H to 0003H.

The setting for the most significant bit of address 0000H specifies whether or not write protection is enabled.

Address	Bit	7	6	5	4	3	2	1	0
0000H	YES/ NO	Upper two digits of start address (00 to 7F)							
0001H		Lower two digits of start address (00to FF)							
0002H		Upper two digits of end address (00 to FF)							
0003H		Lower two digits of end address (00 to FF)							

- Write-protect Bit (Most significant bit of address 0000H)**

1: Write-protected (Yes)

0: Not write-protected (No)

- Write Protection Setting Area**

Start address: 0000H to 7FFFH

End address: 0000H to FFFFH

Write Protection Setting Examples

- Settings to write-protect addresses 0008H through 03E7H:

Address	Bit	7	6	5	4	3	2	1	0
0000H		1	0	0	0	0	0	0	0
		8				0			
0001H		0	0	0	0	1	0	0	0
		0				8			
0002H		0	0	0	0	0	0	1	1
		0				3			
0003H		1	1	1	0	0	1	1	1
		E				7			

- Settings to not write-protect any addresses:

Address	Bit	7	6	5	4	3	2	1	0
0000H		0	0	0	0	0	0	0	0
		0				0			
0001H		0	0	0	0	0	0	0	0
		0				0			
0002H		0	0	0	0	0	0	0	0
		0				0			
0003H		0	0	0	0	0	0	0	0
		0				0			



CHECK!

The write protect function is a function of the V680-CA5D□□-V2 Controller. This function is not supported by reader/writer units of other brands.

MEMO

Section 3

Communications Specifications

☒ Communications Distances	36
☒ Communication Time (Reference)	44

Communications Distances

V680-D1KP52MT

■ Communications Distance Specifications (Certified Performance)

Amplifier	Antenna	ID Tag	Communications distance	
V680-HA63A	V680-HS51	V680-D1KP52MT	Read	0.5 to 6.5 mm (Axis offset: ± 2 mm)
			Write	0.5 to 6.0 mm (Axis offset: ± 2 mm)
	V680-HS51	V680-D1KP52MT embedded in metal (steel)	Read	0.5 to 3.5 mm (Axis offset: ± 2 mm)
			Write	0.5 to 3.0 mm (Axis offset: ± 2 mm)
	V680-HS52	V680-D1KP52MT	Read	0 to 9.0 mm (Axis offset: ± 2 mm)
			Write	0 to 8.5 mm (Axis offset: ± 2 mm)
	V680-HS52	V680-D1KP52MT embedded in metal (steel)	Read	0 to 4.5 mm (Axis offset: ± 2 mm)
			Write	0 to 4.0 mm (Axis offset: ± 2 mm)
	V680-HS63	V680-D1KP52MT	Read	0 to 12.0 mm (Axis offset: ± 2 mm)
			Write	0 to 9.5 mm (Axis offset: ± 2 mm)



CHECK!

When embedding the V680-D1KP52MT into a metal surface, use the V680-HS51, V680-HS52 Antenna. Transmission will not be possible if the V680-HS63 Antenna is used.

• Measurement Conditions

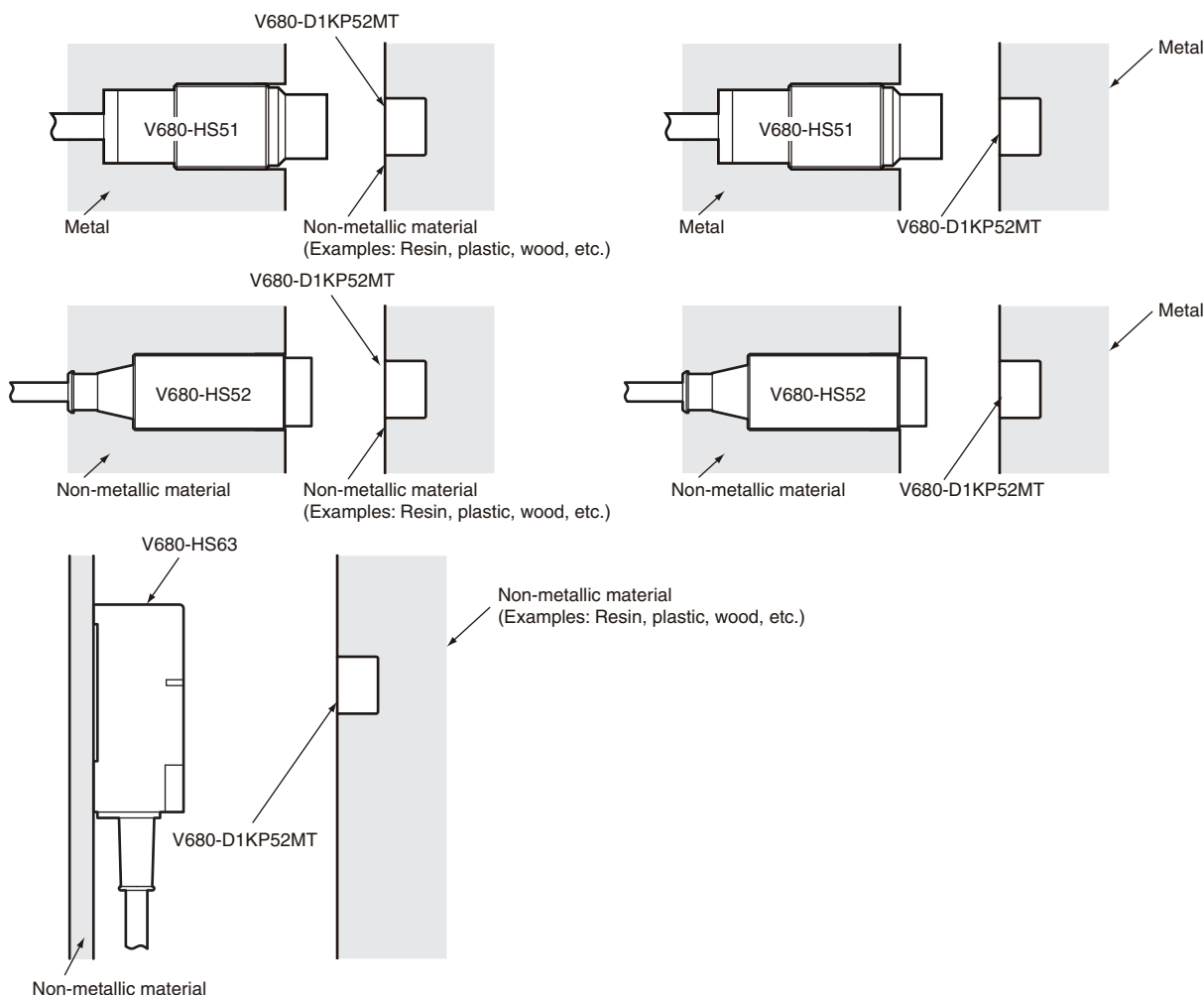

■ Communications Area (Reference)

● V680-HS51 & V680-D1KP52MT

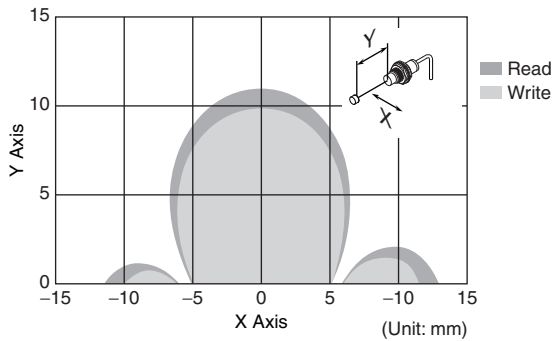

● V680-HS51 & V680-D1KP52MT
Embedded in Metal (Steel)

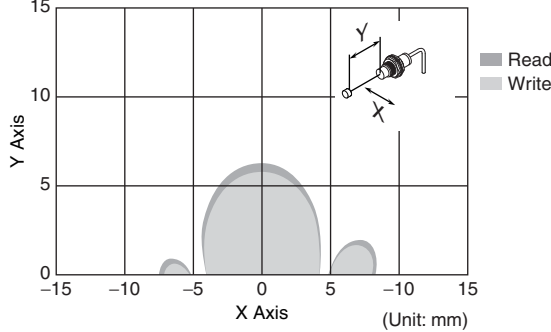

● V680-HS52 & V680-D1KP52MT

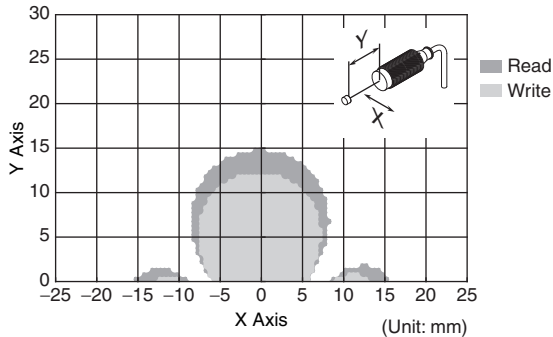

● V680-HS52 & V680-D1KP52MT
Embedded in Metal (Steel)

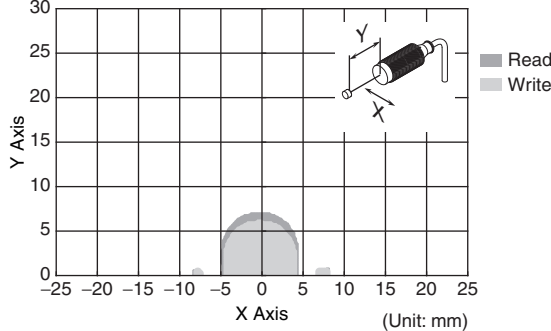

● V680-HS63 & V680-D1KP52MT

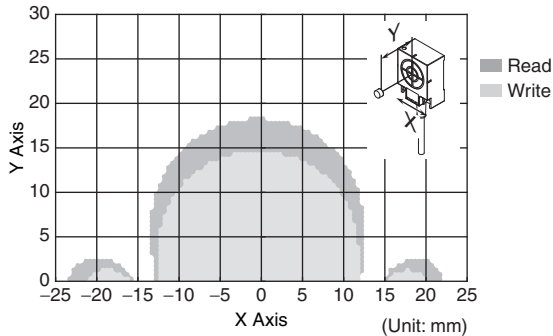

V680-D1KP66T

■ Communications Distance Specifications (Certified Performance)

Amplifier	Antenna	ID Tag	Communications distance	
V680-HA63A	V680-HS52	V680-D1KP66T	Read	0 to 17.0 mm (Axis offset: ± 2 mm)
			Write	0 to 17.0 mm (Axis offset: ± 2 mm)
	V680-HS63	V680-D1KP66T	Read	0 to 30.0 mm (Axis offset: ± 10 mm)
			Write	0 to 25.0 mm (Axis offset: ± 10 mm)
	V680-HS65	V680-D1KP66T	Read	0 to 47.0 mm (Axis offset: ± 10 mm)
			Write	0 to 42.0 mm (Axis offset: ± 10 mm)

• Measurement Conditions

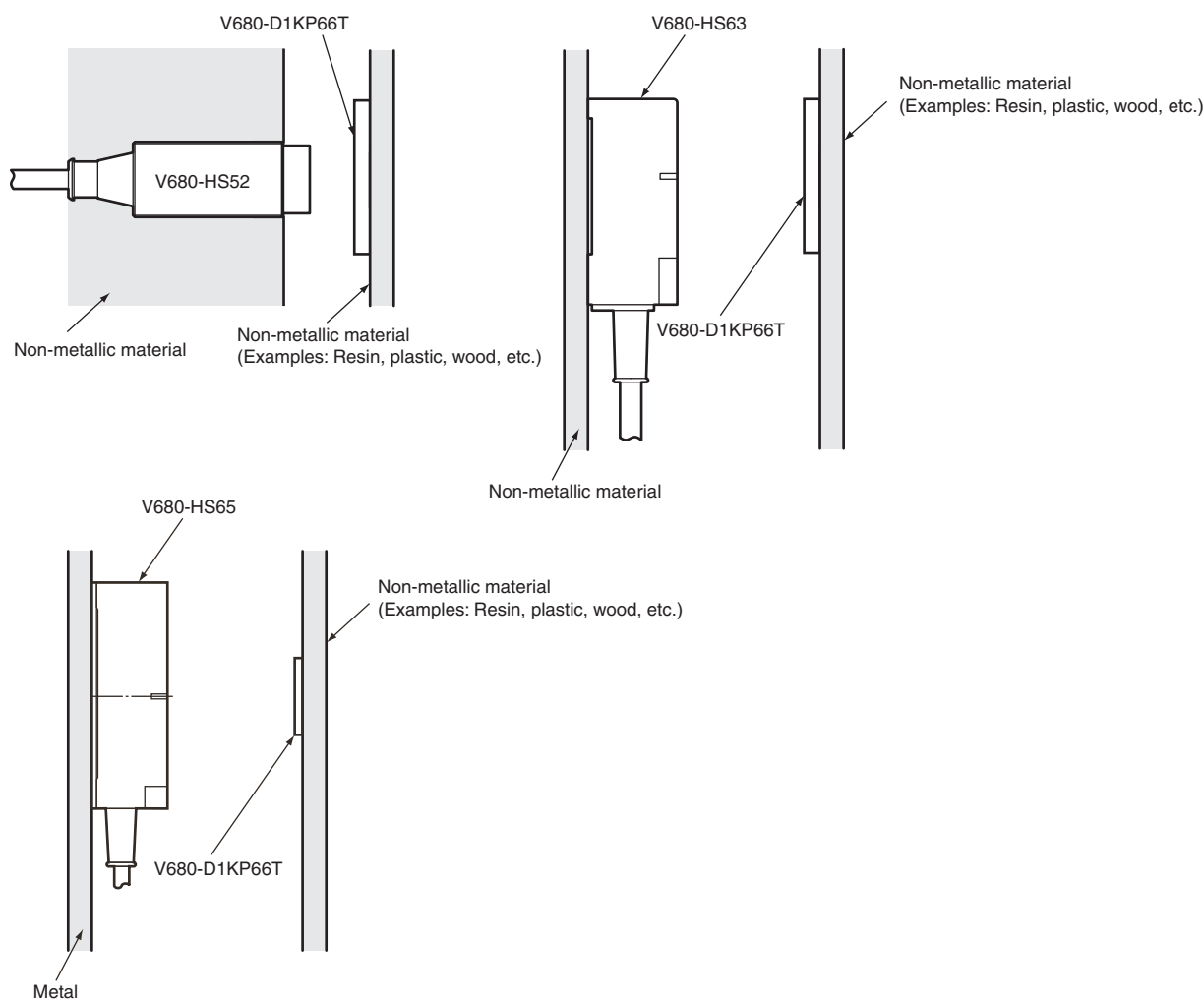

■ Communications Area (Reference)

● V680-HS52 and V680-D1KP66T

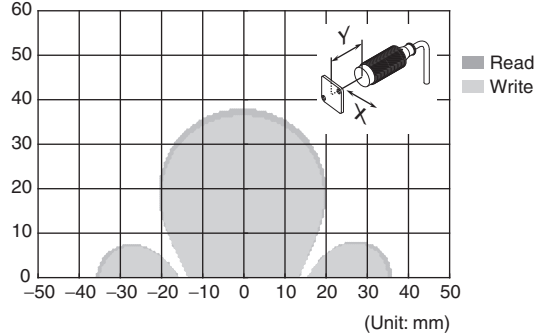

● V680-HS63 and V680-D1KP66T

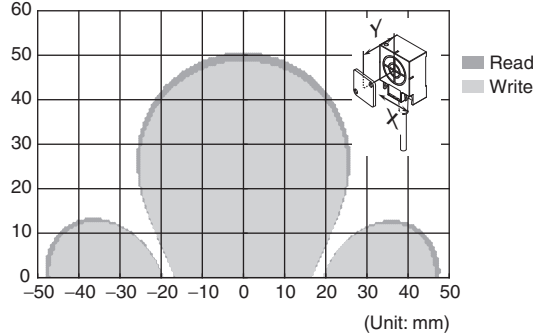

● V680-HS65 and V680-D1KP66T

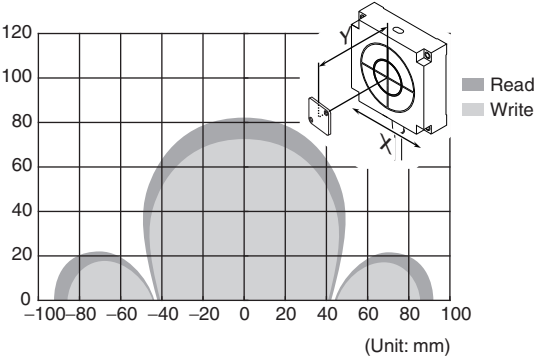

V680-D1KP66MT

■ Communications Distance Specifications (Certified Performance)

Amplifier	Antenna	ID Tag	Communications Distance	
V680-HA63A	V680-HS52	V680-D1KP66MT with metal on back surface (steel)	Read	0 to 16.0 mm (Axis offset: ± 2 mm)
			Write	0 to 14.0 mm (Axis offset: ± 2 mm)
	V680-HS63	V680-D1KP66MT with metal on back surface (steel)	Read	0 to 25.0 mm (Axis offset: ± 10 mm)
			Write	0 to 20.0 mm (Axis offset: ± 10 mm)
	V680-HS65	V680-D1KP66MT with metal on back surface (steel)	Read	0 to 25.0 mm (Axis offset: ± 10 mm)
			Write	0 to 20.0 mm (Axis offset: ± 10 mm)

• Measurement Conditions

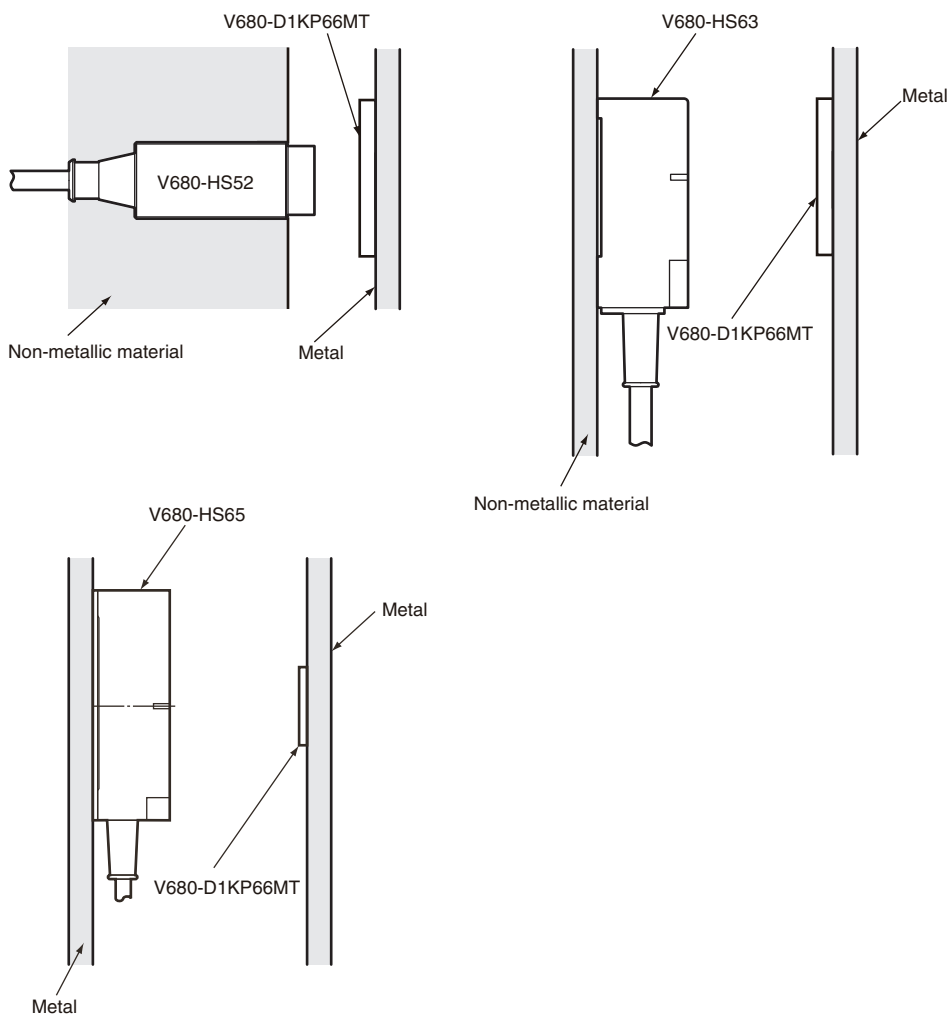

■ Communications Area (Reference)

● V680-HS52 and V680-D1KP66MT with Metal on Back Surface (Steel)

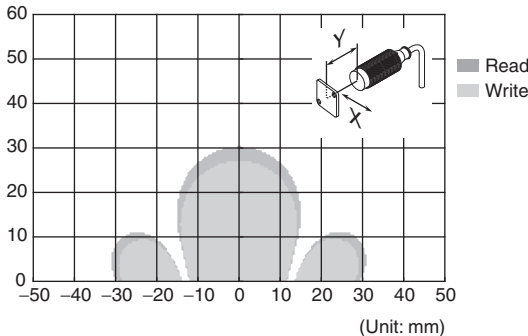

● V680-HS63 and V680-D1KP66MT with Metal on Back Surface (Steel)

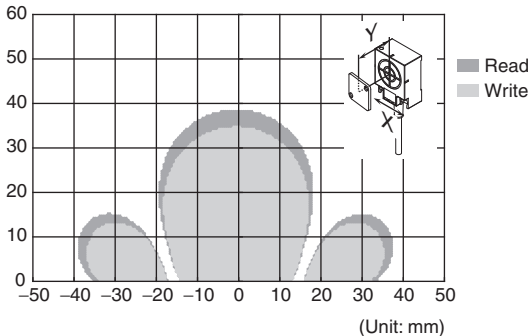

● V680-HS65 and V680-D1KP66MT with Metal on Back Surface (Steel)

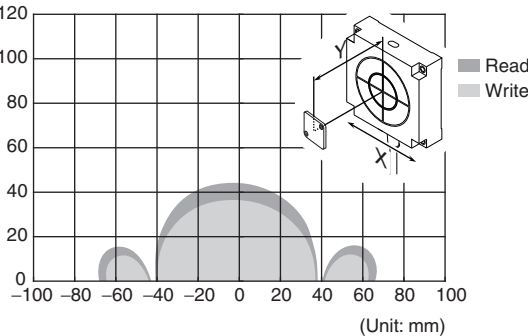

V680-D1KP66T-SP

■ Communications Distance Specifications (Certified Performance)

Amplifier	Antenna	ID Tag	Communications distance	
V680-HA63A	V680-HS52	V680-D1KP66T-SP	Read	0 to 15.0 mm (Axis offset: ± 2 mm)
			Write	0 to 15.0 mm (Axis offset: ± 2 mm)
	V680-HS63	V680-D1KP66T-SP	Read	0 to 25.0 mm (Axis offset: ± 10 mm)
			Write	0 to 20.0 mm (Axis offset: ± 10 mm)
	V680-HS65	V680-D1KP66T-SP	Read	0 to 42.0 mm (Axis offset: ± 10 mm)
			Write	0 to 37.0 mm (Axis offset: ± 10 mm)

• Measurement Conditions

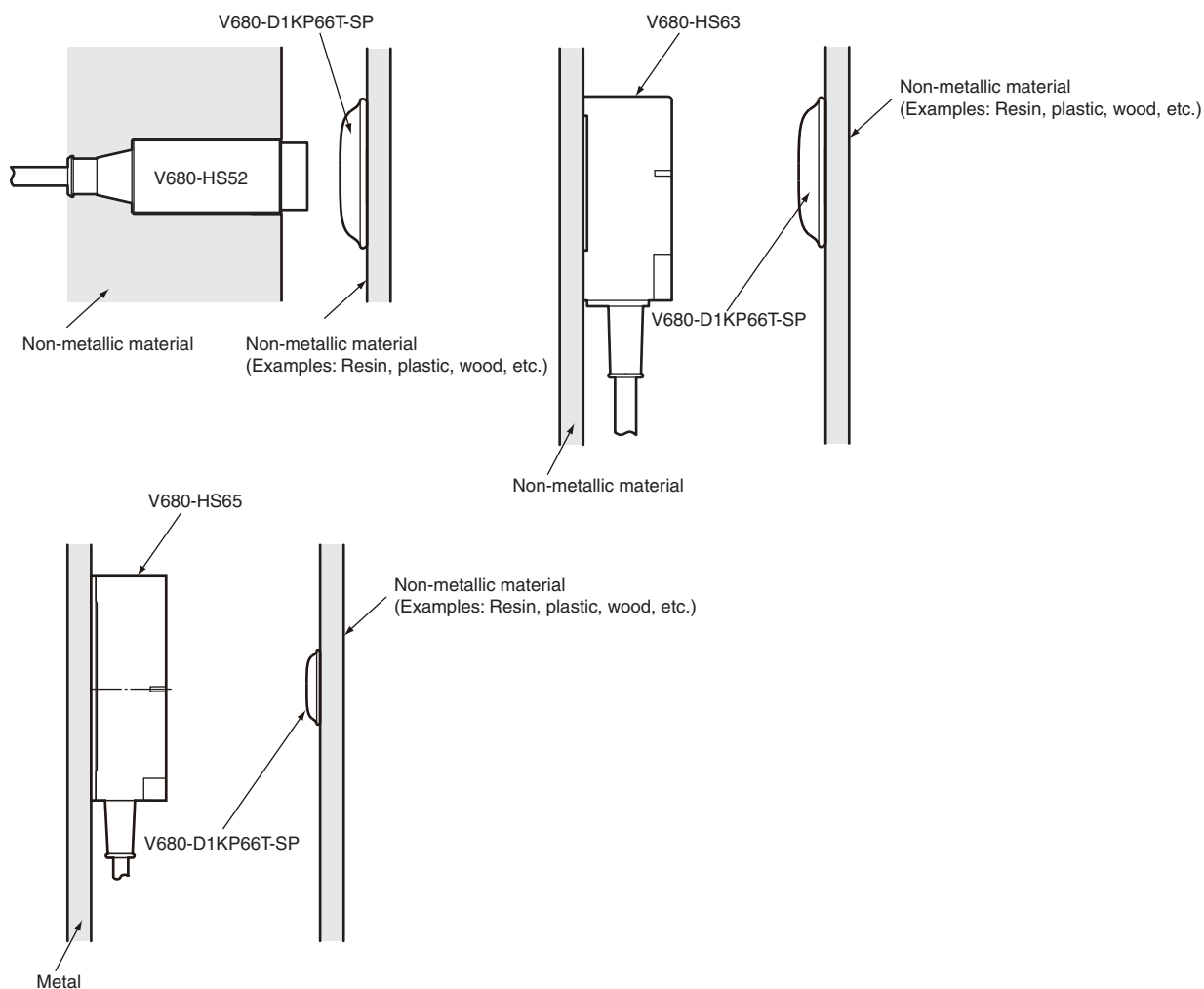

■ Communications Area (Reference)

● V680-HS52 and V680-D1KP66T-SP

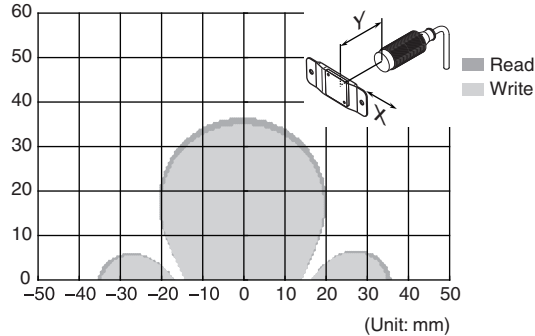

● V680-HS63 and V680-D1KP66T-SP

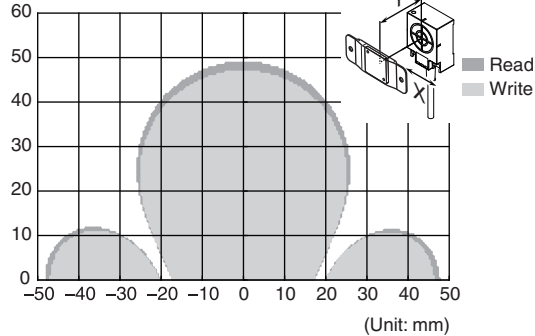

● V680-HS65 and V680-D1KP66T-SP

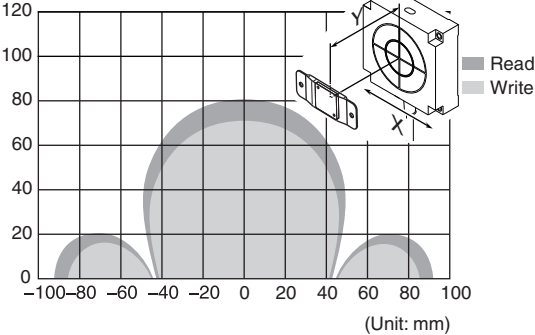

Communication Time (Reference)

Communications Time (Reference)

Communications Time

V680-HA63A:V680-HS□□:V680-D1KP□□

Communications speed setting	Command	Communications time N: No. of bytes processed
Normal mode	Read	$T = 1.3 N + 31$
	Write (with verification)	$T = 2.1 N + 58$
	Write (without verification)	$T = 1.8 N + 56$
High-speed mode (See note.)	Read	$T = 1.0 N + 29$
	Write (with verification)	$T = 1.8 N + 51$
	Write (without verification)	$T = 1.5 N + 47$

Note: When using multi-access or FIFO communications options, normal-mode communications speed will be used regardless of the high-speed mode setting.

Communications speed: Normal mode

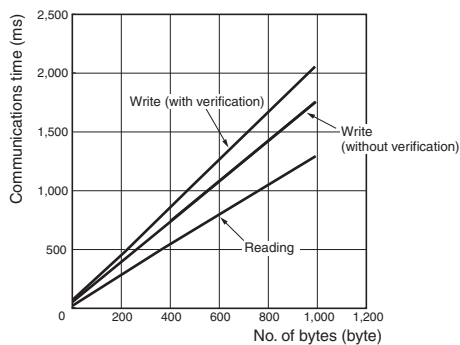

Communications speed: high-speed mode

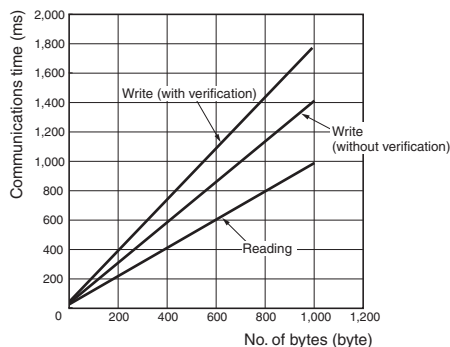

Calculating Tag Speed

When communicating with a moving Tag, specify an AUTO command or POLLING command. The maximum speed for communicating with the Tag can be calculated simply using the following formula.

$$\text{Maximum speed} = \frac{D \text{ (Distance travelled in communications area)}}{T \text{ (Communications time)}}$$

D (Distance travelled in communications area) is calculated from the actual measurement or the communications area between the Antenna and Tag.

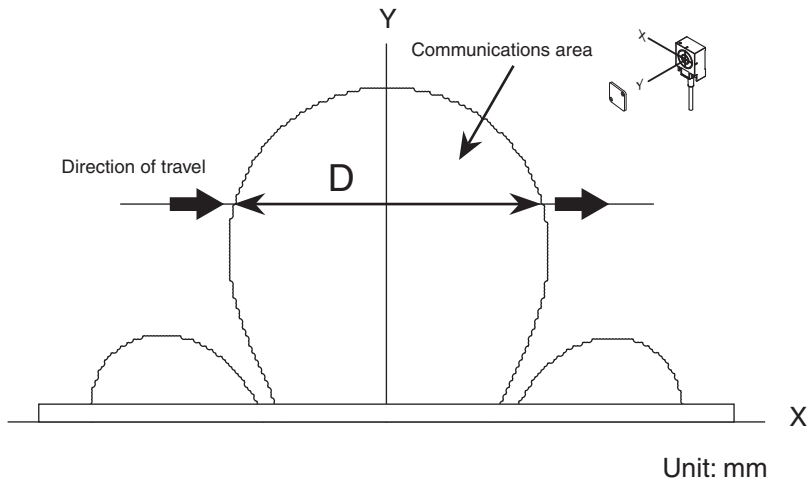

Calculation Example

In this example diagram, the V680-D1KP66T, V680-HA63A, and V680-HS63 are combined and 256 bytes are read.

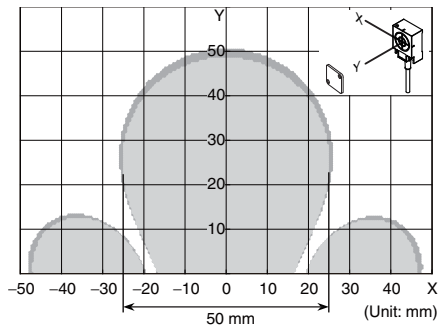

This diagram shows the following:

Distance travelled in communications area (D) = 50 mm when Y (communications distance) = 20 mm

Communications time, $T = 1.3N + 31 = 1.3 \times 256 + 31 = 363.8$ (ms)

Accordingly, the movement speed in this case will be as follows:

$$\frac{\text{Distance travelled in communications area}}{\text{Communications time}} = \frac{50 \text{ (mm)}}{363.8 \text{ (ms)}} = 8.24 \text{ m/min}$$

- Note**
1. The distance travelled in the communications area depends on the read/write distance and the axis offset. Refer to the diagrams in *Communications Area*.
 2. The speed of the Tag is provided as a guideline. Before using the RFID System, run a test to determine the speed under actual operating conditions.
 3. The above values do not take into account the processing of errors in communications with the host device or Tags.

MEMO

Section 4 Installation

☒ Installing Antennas	48
☒ Mounting Amplifiers	54
☒ Installing Tags	56

Installing Antennas

V680-HS51

Install the Antenna using the nuts and toothed washers that are provided on both sides of the mounting material, as shown in the diagram below.

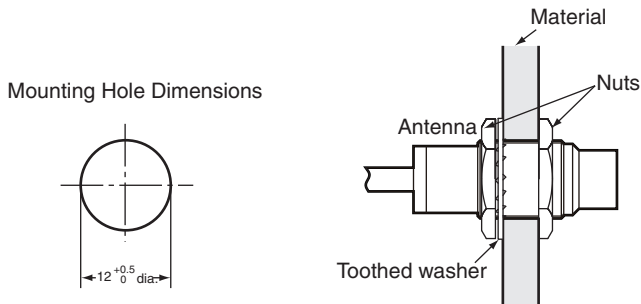

CHECK!

Securely tighten the screws to a maximum torque of 6 N·m.

V680-HS52

Install the Antenna using the nuts and toothed washers that are provided on both sides of the mounting material, as shown in the diagram below.



CHECK!

When the Antenna is mounted to a metal object, the communications distance will be reduced by approximately 10% compared with mounting to a non-metallic object. For details on the effect of metal surrounding the Antenna, refer to *Effect of Surrounding Metals on the Antenna (Reference)* on page 51.



P.51

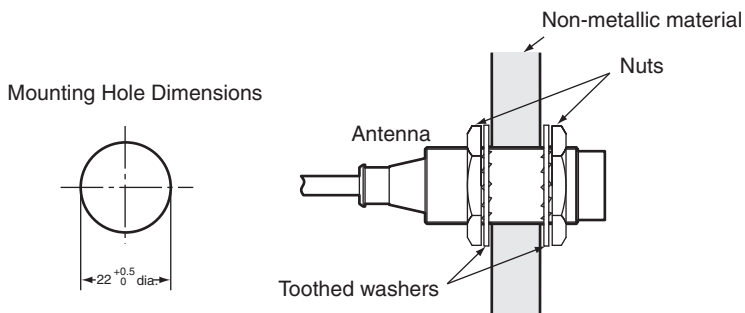

CHECK!

Securely tighten the screws to a maximum torque of 40 N·m.

V680-HS63

■ Installation from the Front

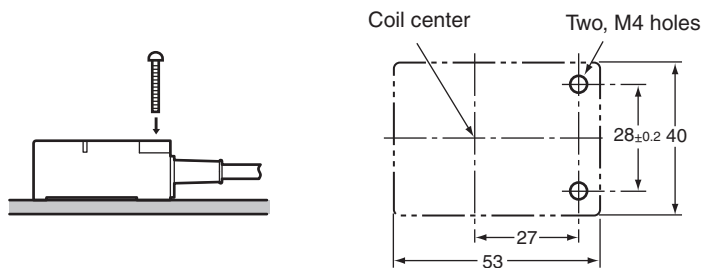

■ Installation from the Back

Insert the nuts that come with the Antenna into sections A.

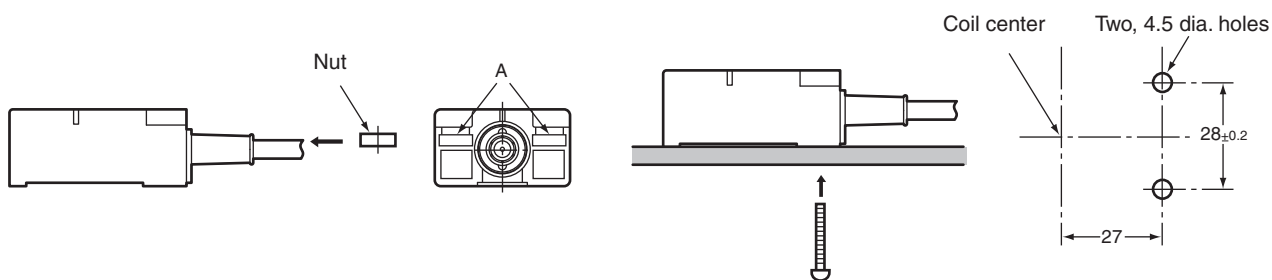

Securely tighten screws to a maximum torque of 1.2 N·m.

V680-HS65

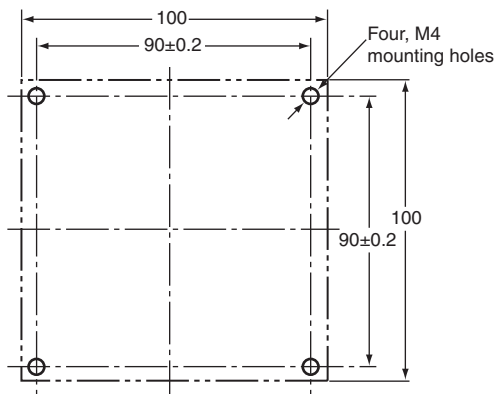

Use M4 screws and spring washers (in four places) for Antenna installation.

Tighten the screws to a torque of 0.7 to 1.2 N·m.

There are no restrictions on the mounting direction or the direction of access to the Tag, but if the Antenna is to be installed near a device such as a conveyance belt, make sure there is no danger of the Antenna being accidentally struck.



Securely tighten screws to a torque of 0.7 to 1.2 N·m.

■ Mounting Bracket Dimensions (Provided Only with the V680-HS65)

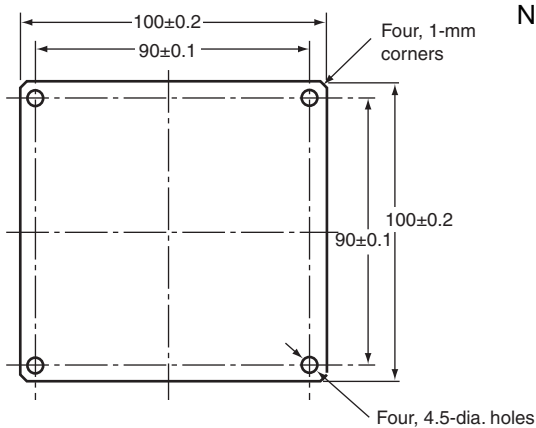

Note: When installing the Antenna, mount it on the enclosed Mounting Bracket. The Mounting Bracket is not necessary, however, if the Antenna is mounted on a metal base that is larger than the Antenna (100 × 100 mm).

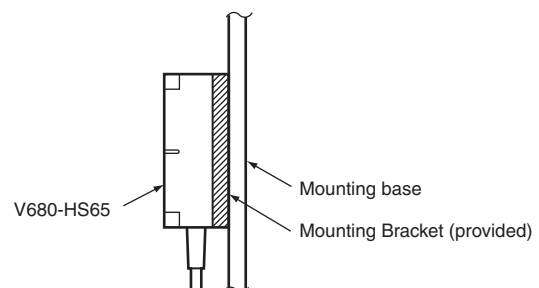

Effect of Surrounding Metals on the Antenna (Reference)

■ V680-HS51

When embedding the Antenna in metal, be sure the metal does not extend beyond the tip of the Antenna.

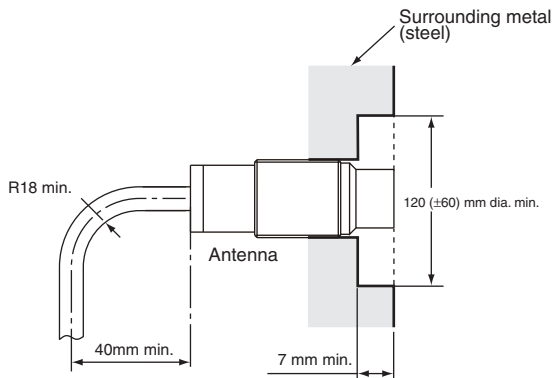

Do not bend the cable into a curve tighter than 18 mm in radius.

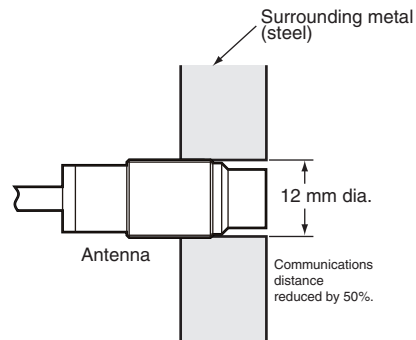

If the metal around the Antenna reaches the coil surface, the communications distance will be reduced significantly compared with mounting to a non-metallic surface.

■ V680-HS52

When embedding the Antenna in metal, be sure the metal does not extend beyond the tip of the Antenna.

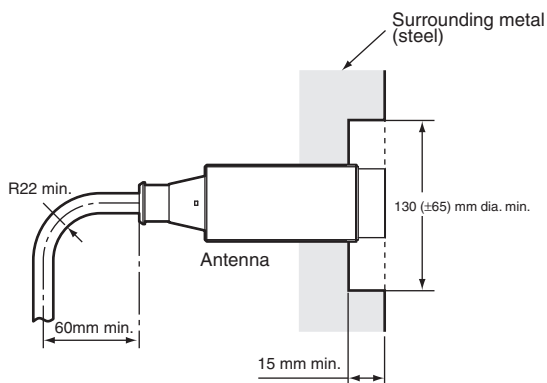

Do not bend the cable into a curve tighter than 22 mm in radius.

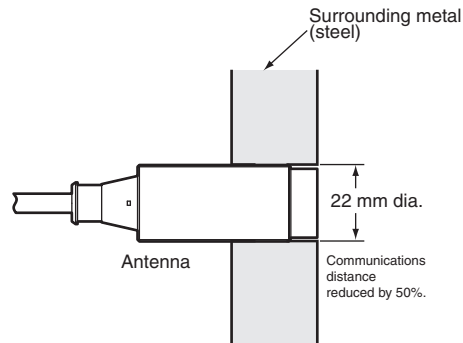

If the metal around the Antenna reaches the coil surface, the communications distance will be reduced significantly compared with mounting to a non-metallic surface.

■ V680-HS63

In addition to surface mounting, it is also possible to embed the V680-HS63 in a metal casing to protect it from being struck by other objects. To prevent malfunctioning, allow a space of at least 30 mm between the Antenna and the sides of the metal casing. If the space is less than 30 mm, the read/write distance will be greatly diminished. In addition, the height of metal casing must not exceed that of the Antenna.

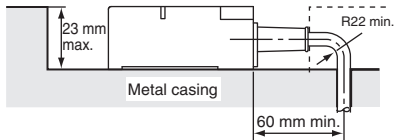

- Note**
1. Do not bend the cable into a curve tighter than 22 mm in radius.
 2. The communications distance will be reduced significantly if the Antenna is installed closer than 30 mm to metal surfaces.

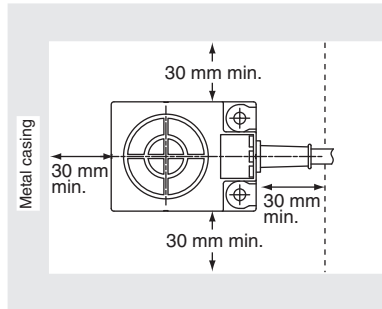

■ V680-HS65

In addition to surface mounting, it is also possible to embed the V680-HS65 in a metal casing to protect it from being struck by other objects. To prevent malfunctioning, allow a space of at least 100 mm between the Antenna and the sides of the metal casing. If the space is less than 100 mm, the read/write distance will be greatly diminished. In addition, the height of metal casing must not exceed that of the Antenna.

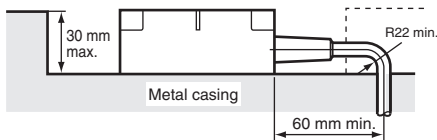

- Note**
1. Do not bend the cable into a curve tighter than 22 mm in radius.
 2. The communications distance will be reduced significantly if the Antenna is installed closer than 100 mm to metal surfaces.

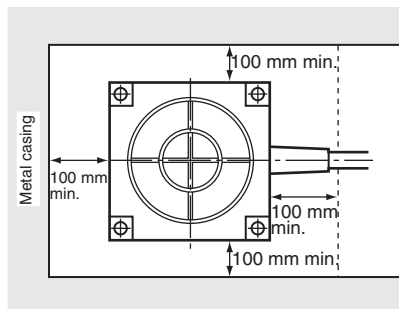

Mutual Interference between Antennas (Reference)

To prevent malfunctioning due to mutual interference when using more than one Antenna, leave sufficient space between them as shown in the following diagrams.

■ V680-HS51

• Installing the Antennas Facing Each Other

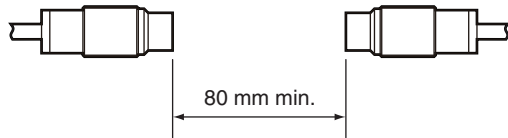

• Installing the Antennas in Parallel

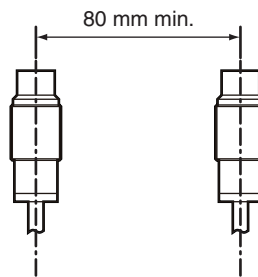

■ V680-HS52

• Installing the Antennas Facing Each Other

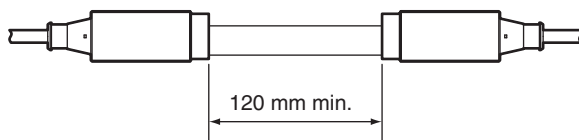

• Installing the Antennas in Parallel

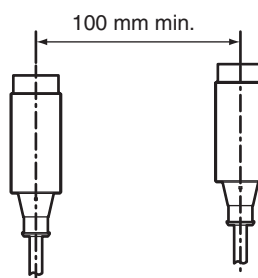

■ V680-HS63

• Installing the Antennas Facing Each Other



• Installing the Antennas in Parallel

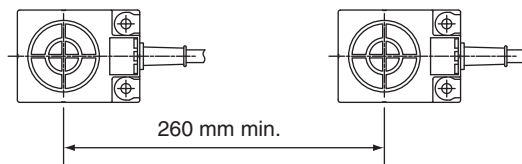

■ V680-HS65

• Installing the Antennas Facing Each Other

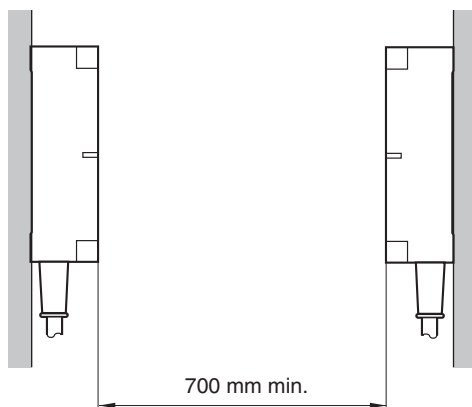

• Installing the Antennas in Parallel

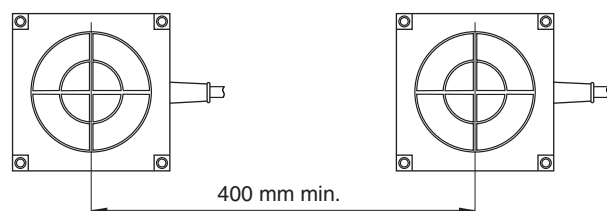

Mounting Amplifiers

V680-HA63A

■ Mounting to DIN Track

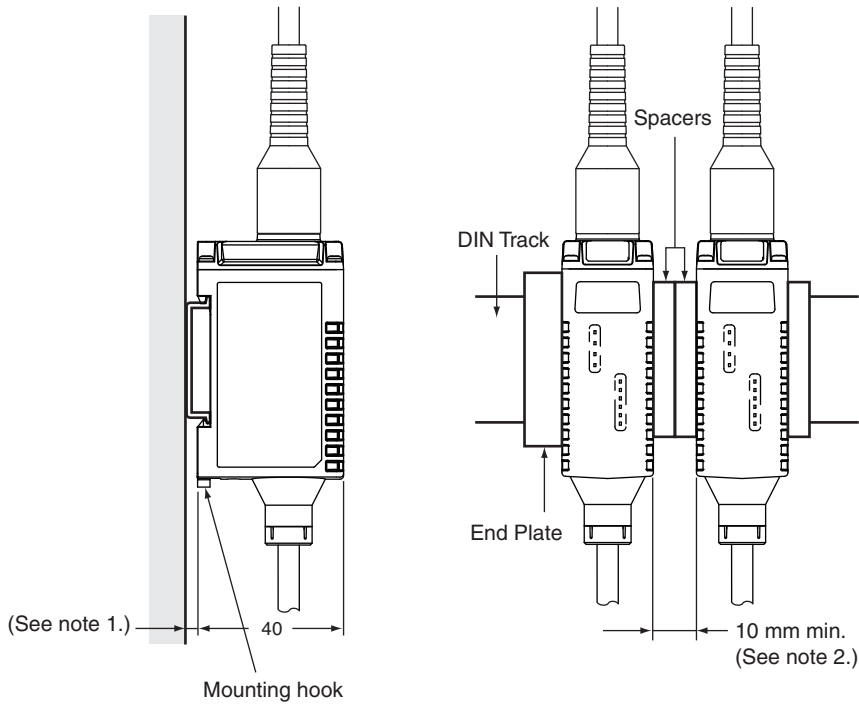

- Note** 1. Consider the height of the DIN Track.
2. Provide a space of at least 10 mm (i.e., at least two spacers) and attach them securely.

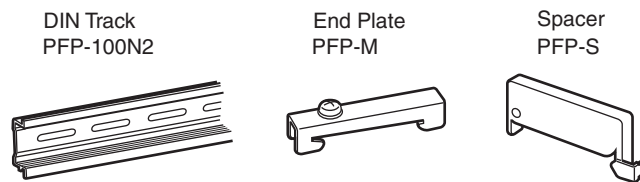
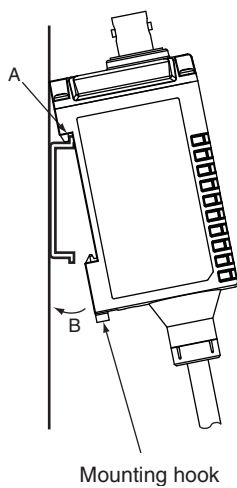

1. When mounting the Amplifier to a DIN Track, first hook section A to the Track and then press in direction B.
2. To remove the Amplifier from the DIN Track, first pull out the mounting hook.

Amplifier Cable Bending Radius

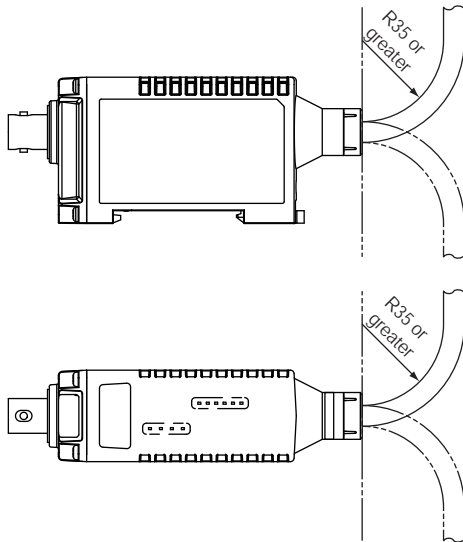

Do not bend the cable past a bending radius of 35 mm.

Attaching/Removing Amplifier and Antenna Connectors

■ Attaching the Connector

1. Hold the Antenna connector, align the key, and insert the connector into the Amplifier connector.
2. Turn the connector clockwise to lock it in place.

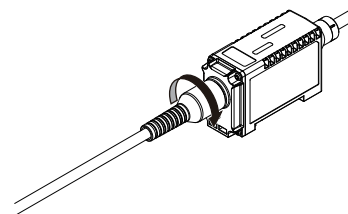
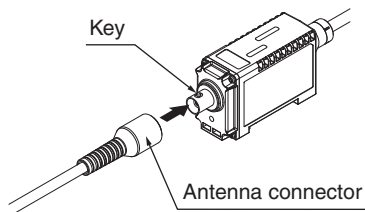

■ Removing the Connector

1. Turn the connector counterclockwise to release the lock.
2. Pull the Antenna connector straight out.

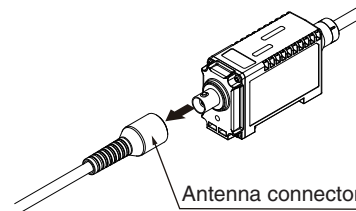
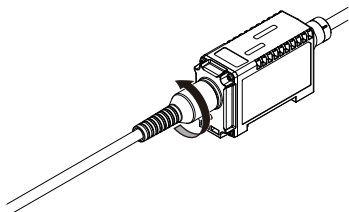

CHECK!

The connector will not come out unless the lock is first released by turning the connector. To remove the cable, release the lock and pull on the connector. Pulling the cable without releasing the lock may break or damage the cable.



CHECK!

Do not pull the Antenna connector over the power of 30 N. The Antenna connector may be broken.

Installing Tags

V680-D1KP52MT

Tag Installation Direction

Mount Tags as shown in the diagram on the right.

The epoxy adhesives listed in the following table are recommended for the given temperature ranges.

Ambient operating temperature	Product name	Manufacturer
-40 to 70°C	Two-part Epoxy-compound Resin: TB2001 (main agent)/ TB2105C (curing agent)	Three Bond Co., Ltd.
	One-part Moisture-curing Elastic Adhesive TB1530	Three Bond Co., Ltd.
-40 to 150°C	One-part Epoxy Resin: TB2285	Three Bond Co., Ltd.
	Two-part Epoxy Resin: TB2087	Three Bond Co., Ltd.

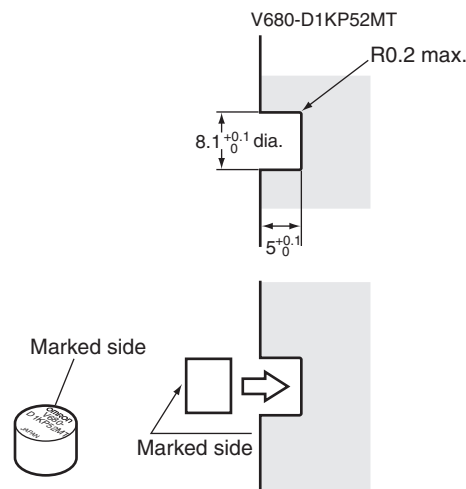

When embedding the V680-D1KP52MT into a metal surface, use the V680-HS52 Antenna. Transmission will not be possible if the V680-HS63 Antenna is used.

Differences in Surrounding Metals

Communications distances are affected by the type of metal in back of or surrounding the Tag, as shown in the following table.

	Steel	SUS	Brass	Aluminum
V680-D1KP52MT	100%	85% to 90%	80% to 85%	80% to 85%

The values for steel are set to 100%

Mutual Interference with Tags (Reference)

Provide the mounting distances indicated below to prevent malfunctions due to mutual interference when using more than one Tag.

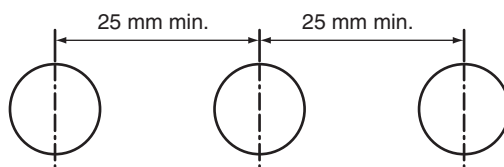

■ Influence of Angle (Reference)

Install Antennas and Tags as close to parallel to each other as possible. Communications are possible even when an Antenna and a Tag are mounted at an angle, but the communications distance will be shortened. The relation between the angle and the communications distance is shown below.

■ Percentage Drop in Communications Distance According to Angle of V680-D1KP52MT

	Tag angle (θ°)				
	0	10	20	30	40
V680-HS51 and V680-D1KP52MT	0%	-1%	-5%	-10%	-15%
V680-HS51 and V680-D1KP52MT (Metal: Steel)	0%	0%	0%	-4%	-28%
V680-HS52 and V680-D1KP52MT	0%	0%	0%	-2%	-6%
V680-HS52 and V680-D1KP52MT (Metal: Steel)	0%	-6%	-13%	-25%	-
V680-HS63 and V680-D1KP52MT	0%	-2%	-5%	-9%	-14%

-: The measurement is not possible because the Tag comes in contact with the Antenna.

• V680-HS51 and V680-D1KP52MT

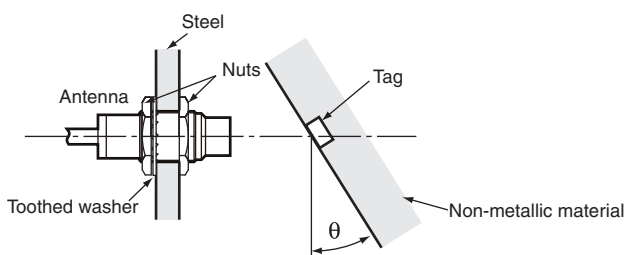

• V680-HS51 and V680-D1KP52MT (Metal: Steel)

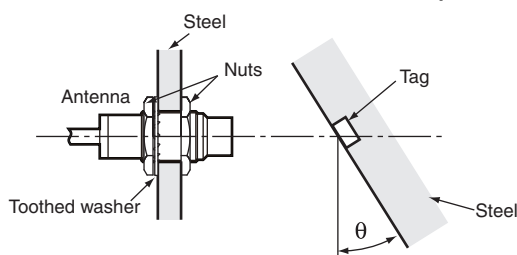

• V680-HS52 and V680-D1KP52MT

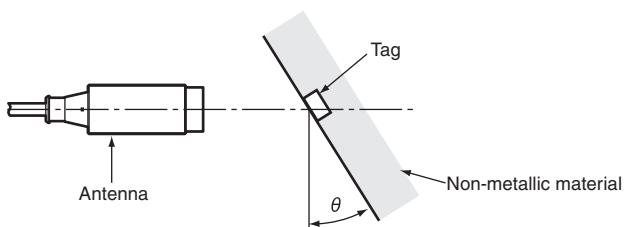

• V680-HS52 and V680-D1KP52MT (Metal: Steel)

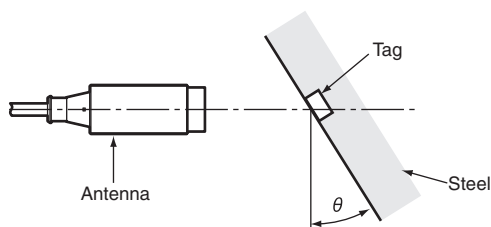

• V680-HS63 and V680-D1KP52MT

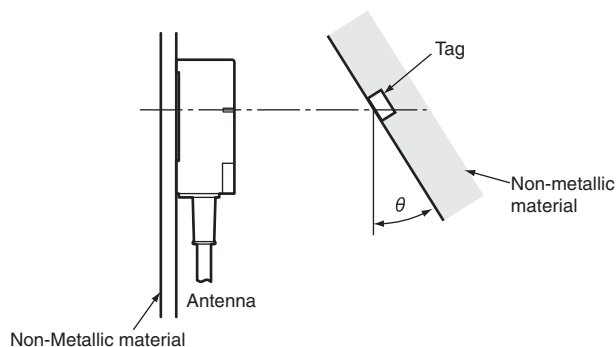

V680-D1KP66T

Tag Installation Direction

Secure the Tag with M3 screws. Tighten the screws to a torque of 0.6 N·m or less.

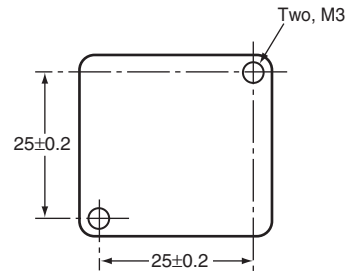

Effect of Metal behind Tags (Reference)

The V680-D1KP66T communications distance is reduced if there is any metal material behind the Tag. If the Tag is to be mounted to metal, then either use a V600-A86 Attachment (sold separately) or insert a non-metal spacer (such as plastic or resin). The relationship between the distance from the Tag to the metal surface and the communications distance is shown below.

The Attachment is 10 mm thick, and more than one Attachment can be stacked.

V600-A86 Attachment Installation

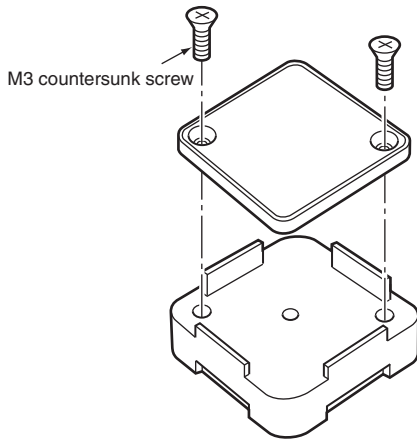

Install so that the mounting holes are aligned.

● V680-HS52 and V680-D1KP66T

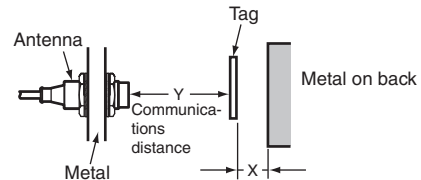
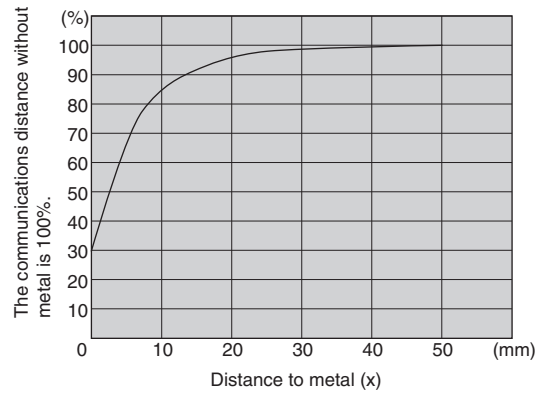

● V680-HS63 and V680-D1KP66T

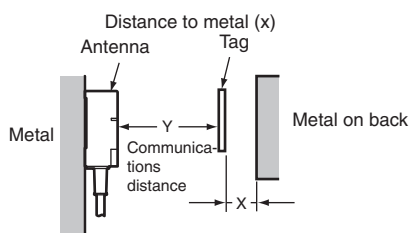
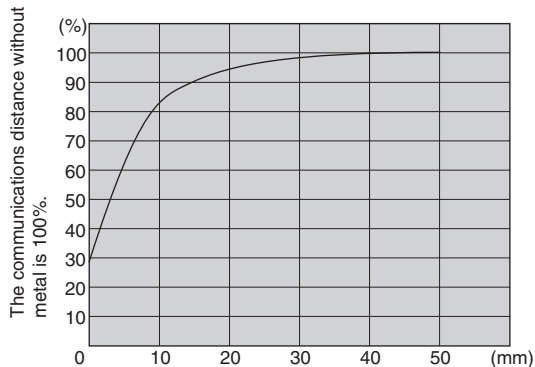

● V680-HS65 and V680-D1KP66T

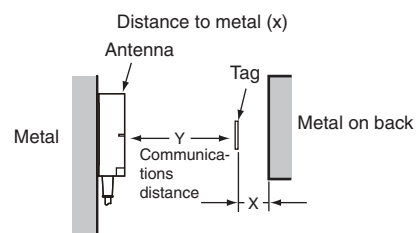
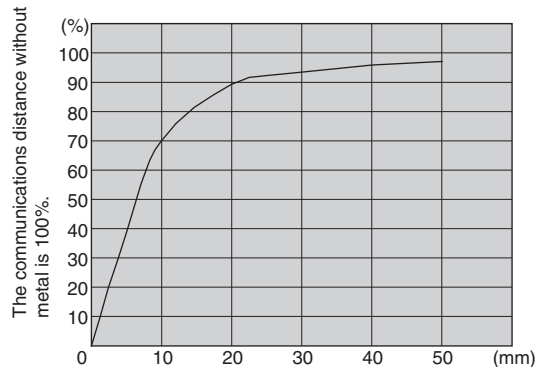

■ Mutual Interference with Tags (Reference)

To prevent malfunctioning due to mutual interference when using more than one Tag, leave sufficient space between them as shown in the following diagram.

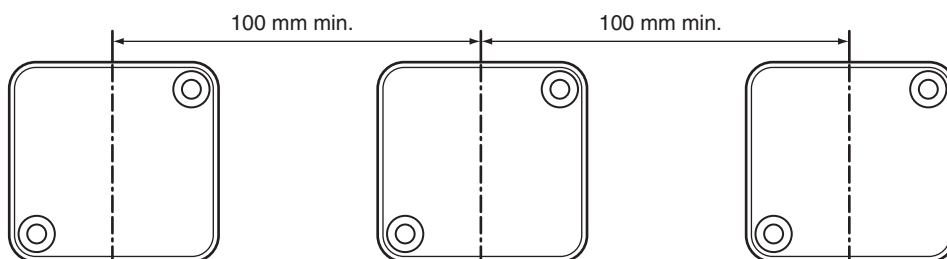

■ Influence of Tag Angle (Reference)

Install Antennas and Tags as close to parallel to each other as possible. Communications are possible even when an Antenna and a Tag are mounted at an angle, but the communications distance will be shortened. The relation between the angle and the communications distance is shown below.

■ Percentage Drop in Communications Distance According to Angle of V680-D1KP66T

	Tag angle (θ°)				
	0	10	20	30	40
V680-HS52 and V680-D1KP66T	0%	-1%	-2%	-4%	-7%
V680-HS63 and V680-D1KP66T	0%	-2%	-3%	-5%	-9%
V680-HS65 and V680-D1KP66T	0%	-1%	-3%	-6%	-11%

• V680-HS52 and V680-D1KP66T

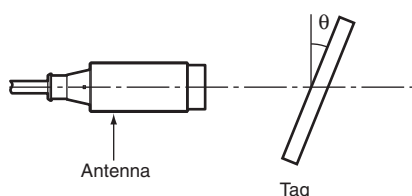

• V680-HS63 and V680-D1KP66T

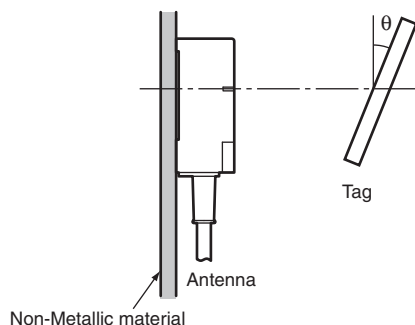

• V680-HS65 and V680-D1KP66T

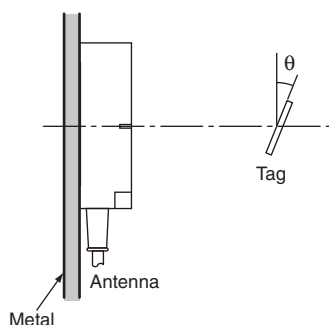

V680-D1KP66MT

Tag Installation Direction

Mount the V680-D1KP66MT to a metal surface, and secure the Tag with M3 screws. Tighten the screws to a torque of 0.6 N·m or less.

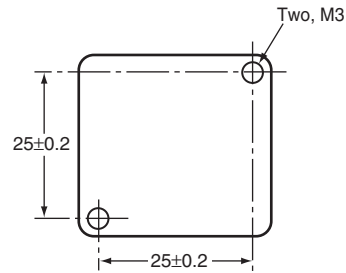

Effect of Surrounding Metals

The V680-D1KP66MT can be surface-mounted or it can be embedded in metal. If it is embedded in metal, the height of the metal casing must not exceed that of the Tag.

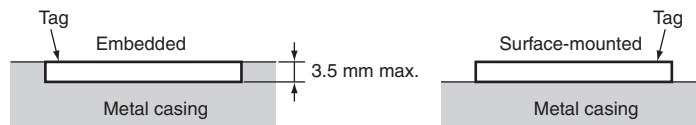

● V680-HS52 and V680-D1KP66MT

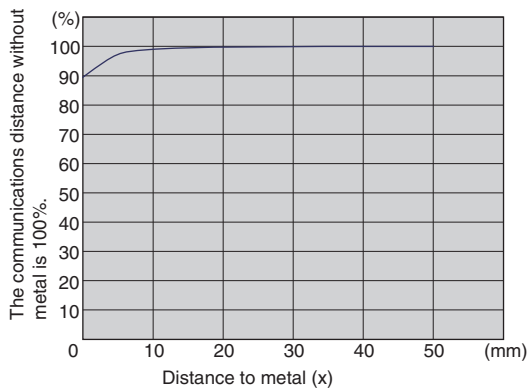

● V680-HS63 and V680-D1KP66MT

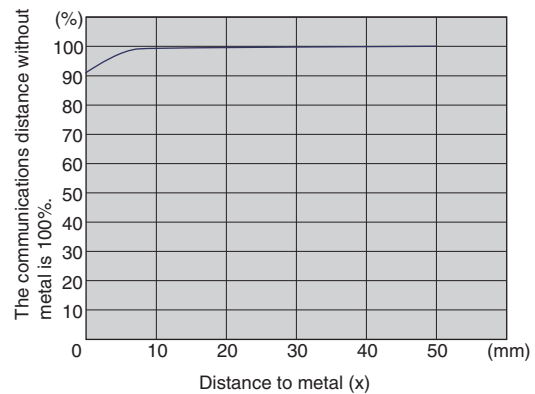

● V680-HS65 and V680-D1KP66MT

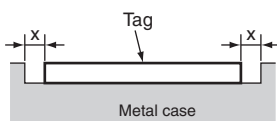
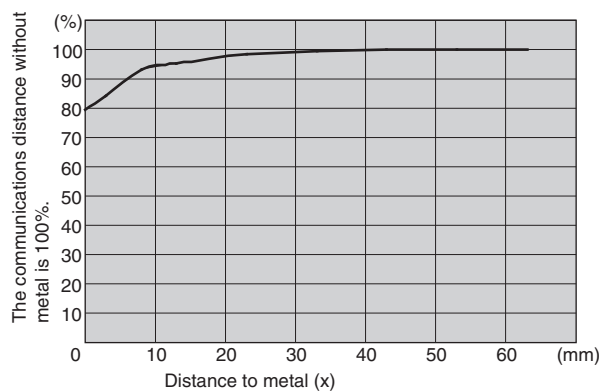

■ Mutual Interference with Tag (Reference)

To prevent malfunctioning due to mutual interference when using more than one Tag, leave sufficient space between them as shown in the following diagram.

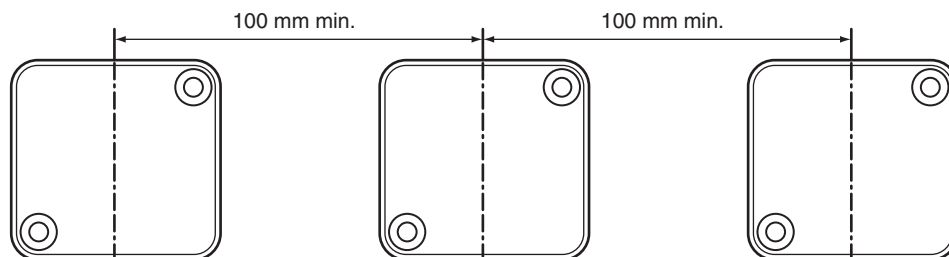

■ Influence of Tag Angle (Reference)

Install Antennas and Tags as close to parallel to each other as possible. Communications are possible even when an Antenna and a Tag are mounted at an angle, but the communications distance will be shortened. The relation between the angle and the communications distance is shown below.

■ Percentage Drop in Communications Distance According to Angle of V680-D1KP66MT

	Tag angle (θ°)				
	0	10	20	30	40
V680-HS52 and V680-D1KP66MT (Metal: Steel)	0%	-1%	-2%	-5%	-9%
V680-HS63 and V680-D1KP66MT (Metal: Steel)	0%	-1%	-4%	-7%	-13%
V680-HS65 and V680-D1KP66MT (Metal: Steel)	0%	-1%	-6%	-15%	-

-: The measurement is no possible because the Tag comes in contact with the Antenna.

• V680-HS52 and V680-D1KP66T (Metal: Steel)

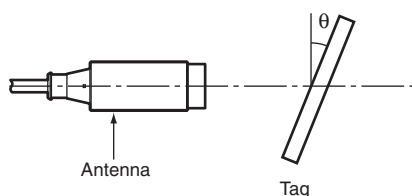

• V680-HS63 and V680-D1KP66T (Metal: Steel)

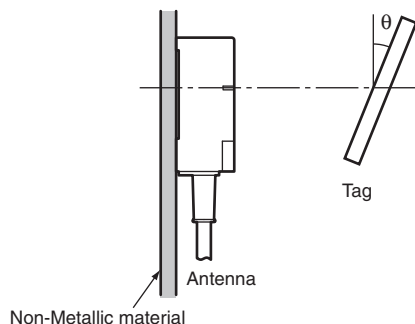

• V680-HS65 and V680-D1KP66T (Metal: Steel)

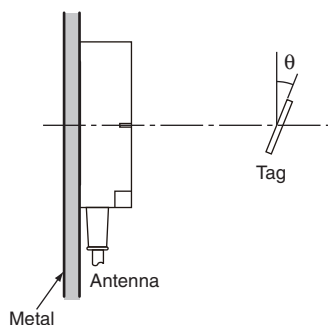

V680-D1KP66T-SP

Tag Installation Direction

Mount the ID Tags with M5 screws and washers. Tightening torque: 1.2 N.m.

There are no restrictions to the mounting direction of the ID Tags or the direction of movement for Antennas.

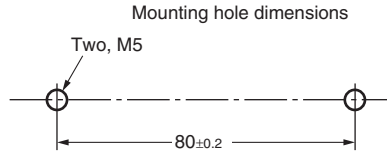
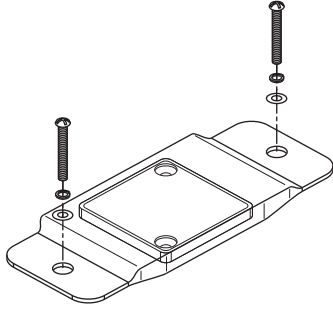

Effect of Metal behind Tags (Reference)

Mounting ID Tags to metal workpieces or palettes will affect the communications capabilities. Place non-metallic parts (e.g., plastic or resin) between the metallic parts by referring to the following relationship between the distance between the ID Tag and the metallic body versus the communications distance.

● V680-HS52 and V680-D1KP66T-SP

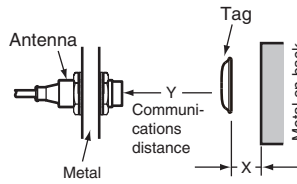
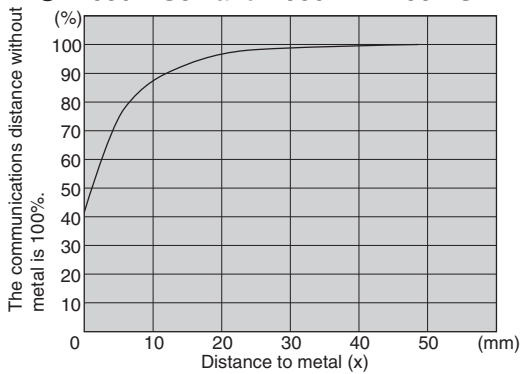

● V680-HS63 and V680-D1KP66T-SP

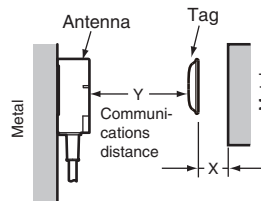
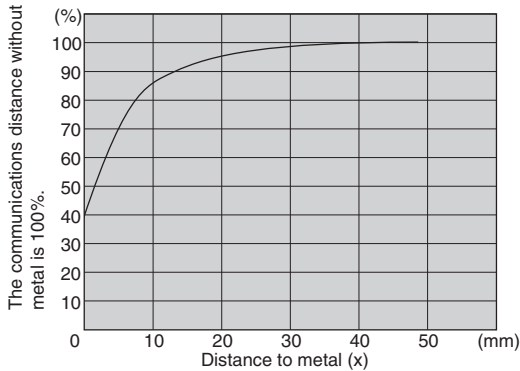

● V680-HS65 and V680-D1KP66T-SP

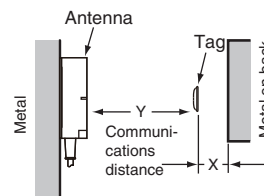
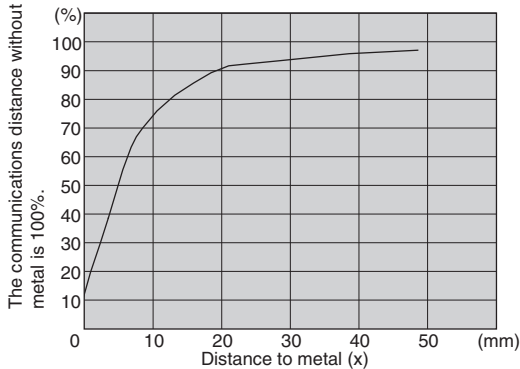

■ Mutual Interference with Tag (Reference)

To prevent malfunctioning due to mutual interference when using more than one Tag, leave sufficient space between them as shown in the following diagram.

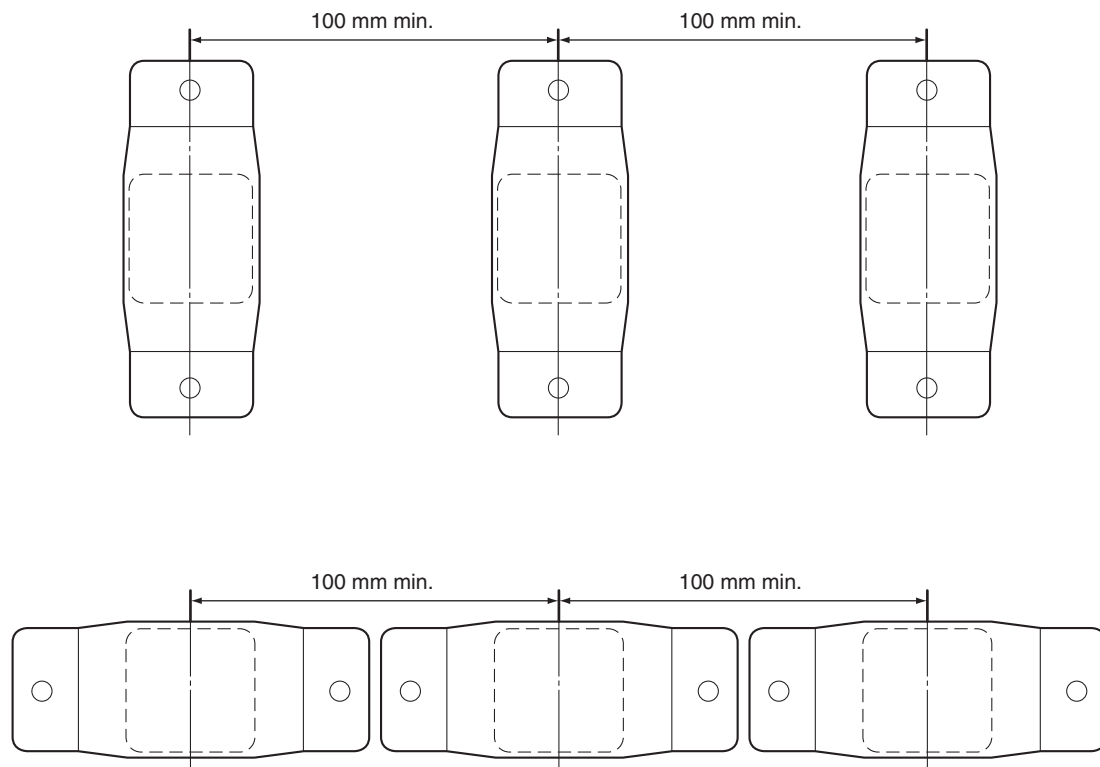

■ Influence of Tag Angle (Reference)

Install Antennas and Tags as close to parallel to each other as possible. Communications are possible even when an Antenna and a Tag are mounted at an angle, but the communications distance will be shortened. The relation between the angle and the communications distance is shown below.

■ Percentage Drop in Communications Distance According to Angle of V680-D1KP66T-SP

	Tag angle (θ°)				
	0	10	20	30	40
V680-HS52 and V680-D1KP66T-SP	0%	-1%	-2%	-4%	-7%
V680-HS63 and V680-D1KP66T-SP	0%	-2%	-3%	-5%	-9%
V680-HS65 and V680-D1KP66T-SP	0%	-1%	-3%	-6%	-11%

• V680-HS52 and V680-D1KP66T-SP

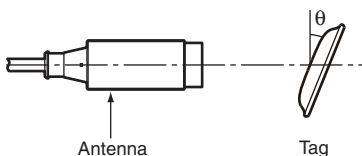

• V680-HS63 and V680-D1KP66T-SP

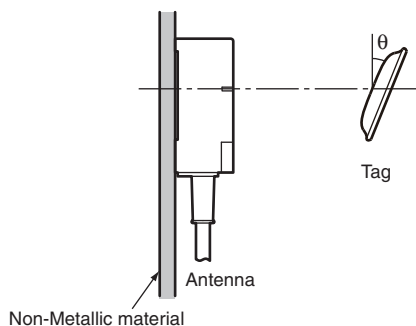

• V680-HS65 and V680-D1KP66T-SP

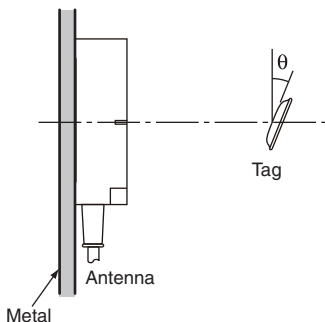

Section 5

Chemical Resistance

☒ Chemical Resistance of the Antennas	66
☒ Chemical Resistance of Tags	67
☒ Degree of Protection	72

Chemical Resistance of the Antennas

Applicable Models

V680-HS51 V680-HS52-W/R V680-HS63-W/R V680-HS65-W/R

ABS resin is used for case material and epoxy resin for filling material. Refer to the following lists and do not use chemicals that affect ABS and epoxy resin.

Chemicals That Cause Deformations, Cracks, Etc.

ABS resin	Epoxy resin
Trichlene, acetone, xylene, toluene, gasoline, creosol, methylene chloride, phenol, cyclohexane, aqua regia, chromic acid, sulfuric acid (90% RT), methyl ethyl ketone, aniline, nitrobenzine, monochlorobenzene, pyridine, nitric acid (60% RT), formic acid (80% RT)	Aqua regia, chromic acid, sulfuric acid (90% RT), nitric acid (60% RT), ammonia solution, acetone, methylene chloride, phenol

Chemicals That May Cause Discoloration, Swelling, Etc.

ABS resin	Epoxy resin
Hydrochloric acid, alcohol, Freon, sodium hydroxide, hydrogen peroxide, benzene, sulfuric acid (10% RT), nitric acid (10% RT), phosphoric acid (85% RT), ammonia solution	Sulfuric acid (10% RT), nitric acid (10% RT), hydrochloric acid (30% RT), acetic acid (50% RT), oxalic acid, calcium hydroxide, benzene, creosol, alcohol, cyclohexane, toluene, xylene, benzene, grease

Chemicals That Do Not Affect ABS Resin or Epoxy Resin

ABS resin	Epoxy resin
Ammonia, kerosine, mineral oil, developer, Yushiroken S50, Chemi-Cool Z, Velocity No. 3, Yushiroken EEE-30Y, petroleum, grease, acetic acid, oxalic acid, calcium hydroxide, phosphoric acid (30% RT), hydrochloric acid (10% RT), potassium hydroxide	Ammonia, hydrochloric acid (10% RT), potassium hydroxide, petroleum, gasoline, Yushiroken S50, Chemi-Cool Z, Velocity No. 3, Yushiroken EEE-30Y

Note: The above results are from tests conducted at room temperature (23°C). Even if the chemicals do not affect the ABS or epoxy resins at room temperature, they may affect the resins at higher or lower temperatures. Check the chemicals carefully in advance.

Chemical Resistance of Tags

Applicable Model

V680-D1KP52MT

PPS resin is used for case material and epoxy resin for filling material. Refer to the following lists and do not use chemicals that affect PPS and epoxy resin.

Tags cannot be used in applications with explosion-proof specifications.

Chemicals That Cause Deformations, Cracks, Etc.

PPS resin	Epoxy resin
Aqua regia	Aqua regia, chromic acid, sulfuric acid (90% RT), nitric acid (60% RT), ammonia solution, acetone, methylene chloride, phenol

Chemicals That May Cause Discoloration, Swelling, Etc.

PPS resin	Epoxy resin
Nitric acid (60% RT)	Sulfuric acid (10% RT), nitric acid (10% RT), hydrochloric acid (30% RT), acetic acid (50% RT), oxalic acid, calcium hydroxide, benzene, creosol, alcohol, cyclohexane, toluene, xylene, benzene, grease

Chemicals that Do Not Affect PPS Resin or Epoxy Resin

PPS resin	Epoxy resin
Hydrochloric acid (37%RT), sulfuric acid (98%RT), nitric acid (40%RT), Hydrogen fluoride solution (40%RT), chromic acid (40%RT), hydrogen peroxide (28%RT), sodium hydroxide solution (60%RT), ammonia solution (28%RT), sodium chloride (10%RT), sodium carbonate (20%RT), sodium hypochlorite, phenol solution (5%RT), glacial acetic acid, acetic acid, oleic acid, Methyl alcohol (95%RT), ethyl alcohol (95%RT), Ethyl acetate, sebacic acid, diethylhexyl, acetone, diethyl ether, n-heptane, 2-2-4 trimethylpentane, benzene, toluene, aniline, mineral oil, gasoline, insulating oil, dichloroethylene, carbon tetrachloride	Ammonia, hydrochloric acid (10% RT), potassium hydroxide, petroleum, gasoline, Yushiroken S50, Chemi-Cool Z, Velocity No. 3, Yushiroken EEE-30Y, methyl ethyl ketone, sodium hydroxide (10%RT)

Note: The above results are from tests conducted at room temperature (23°C). Even if the chemicals do not affect the PPS or epoxy resins at room temperature, they may affect the resins at higher or lower temperatures. Check the chemicals carefully in advance.

Applicable Models

V680-D1KP66T/66MT

Chemical		At room temperature	At 90°C
Hydrochloric acid	37%	A	A
	10%	A	A
Sulfuric acid	98%	A	B
	50%	A	A
	30%	A	A
	3%	A	A
	60%	B	C
	40%	A	B
	10%	A	A
	40%	A	A
Hydrogen fluoride solution	40%	A	A
Chromic acid	40%	A	A
Hydrogen peroxide solution	28%	A	B
	3%	A	A
Sodium hydroxide solution	60%	A	A
	10%	A	A
	1%	A	A
Ammonia solution	28%	A	B
	10%	A	B
Sodium chloride	10%	A	A
Sodium carbonate	20%	A	A
	2%	A	A

Chemical		At room temperature	At 90°C
Sodium hypochlorite		A	A
Phenol solution	5%	A	A
Glacial acetic acid		A	A
Acetic acid		A	A
Oleic acid		A	A
Methyl alcohol	95%	A	A
Ethyl alcohol	95%	A	A
Ethyl acetate		A	A
Sebacic acid diethylhexyl		A	A
Acetone		A	A
Diethyl ether		A	A
n-heptane		A	A
2-2-4 trimethylpentane		A	A
Benzene		A	A
Toluene		A	A
Aniline		A	A
Mineral oil		A	A
Gasoline		A	A
Insulating oil		A	A
Dichloroethylene		A	A
Carbon tetrachloride		A	A

A: Has no adverse effect, B: May cause discoloration, swelling, etc., C: Causes deformation, cracks, etc.



The above table shows the extent of changes in PPS resin exposed to each chemical at room temperature and at 90°C. If actual chemicals, concentrations, and temperatures are different from those shown in the tables, always conduct tests under the actual conditions in which the Tags are to be used.

Applicable Models

V680-D1KP66T-SP

Chemical Resistance of Fluoroplastic PFA (Reference)

PFA: Tetrafluorethylene-Perfluoroalkylvinylether Copolymer

Fluoroplastic PFA does not react with most chemicals except molten alkali metal, hot pressurized fluorine (F₂), and some halogen derivatives. The following tables show the results of tests in which PFA was soaked in or exposed to commonly used organic and inorganic chemicals. In these tests, a compression-molded test piece (1.3 mm thick) was soaked in the chemical at a specified temperature for a week (168 hours) and taken out of the chemical, then the weight change, tensile strength, and elongation of the test piece were immediately measured. If the change in the tensile strength is 15 % or less, the change in the elongation is 10 % or less, and the increase in the weight is less than 0.5 %, the results of the test can be considered normal.

If PFA is exposed to trichloroacetic acid, tri-n-butyl phosphate, perchloroethylene, carbon tetrachloride, and other liquids (which easily make resin surfaces wet) at a high temperature, it tends to increase its weight due to absorption and reduce its tensile strength. Even when PFA absorbs chemicals and solvents, its molecular structure will not change. If, however, PFA is subject to temperature or pressure changes or mechanical damage when it has absorbed chemicals, the chemicals will repeatedly expand and contract inside PFA, causing mechanical problems such as cracks and bulging. In fact, this problem occurs with any kind of plastic.

Inorganic Chemicals

Chemical name	Test temperature (°C)	Resulting characteristics (%)		Weight increase rate (%)
		Tensile strength	Elongation	
concentrated hydrochloric acid	120	98	100	0.0
Concentrated sulfuric acid	120	95	98	0.0
Hydrofluoric acid (60%)	23	99	99	0.0
Fuming sulfuric acid	23	95	96	0.0
Aqua regia	120	99	100	0.0
Chromic acid (50%)	120	93	97	0.0
Concentrated nitric acid	120	95	98	0.0
Fuming nitric acid	23	99	99	0.0
Concentrated ammonia solution	66	98	100	0.0
Caustic soda (50%)	120	93	99	0.4
Hydrogen peroxide solution (30%)	23	93	95	0.0
Bromine	23	99	100	0.5
Chlorine	120	92	100	0.5
Ferrous chloride (25%)	100	93	98	0.0
Zinc chloride (25%)	100	96	100	2.7
Chlorosulfonic acid	151	91	100	2.7
Concentrated phosphoric acid	100	93	100	0.0

▪ Organic Chemicals

Chemical name	Test temperature (°C)	Resulting characteristics (%)		Weight increase rate (%)
		Tensile strength	Elongation	
Glacial acetic acid	118	95	100	0.4
Acetic anhydride	139	91	99	0.3
Trichloroacetic acid	196	90	100	2.2
Isooctane	99	94	100	0.7
Naphtha	100	91	100	0.5
Mineral oil	180	87	95	0.0
Toluene	110	88	100	0.7
o-creosol	191	92	96	0.2
Nitrobenzene	210	90	100	0.3
Benzyl alcohol	205	93	99	0.3
Aniline	185	94	100	0.3
n-butylamine	78	86	97	0.4
Ethylenediamine	117	96	100	0.1
Tetrahydrofuran	66	88	100	0.1
Benzaldehyde	179	90	99	0.5
Cyclohexane	156	92	100	0.4
Methyl ethyl ketone	80	90	100	0.4
Acetophenone	202	90	100	0.6
Dimethylphtalate	200	98	100	0.3
n-butyl acetate	125	93	100	0.5
Tri-n-butyl phosphate	200	91	100	2.0
Methylene chloride	40	94	100	0.8
Perchloroethylene	121	86	100	2.0
Carbon tetrachloride	77	87	100	2.3
Dimethyl formamide	154	96	100	0.2
Dimethyl sulfoxide	189	95	100	0.1
Dioxane	101	92	100	0.6
Reference: <i>Fluoroplastics Handbook</i> , The Nikkan Kogyo Shimbun Ltd. (Takaomi Satogawa)				

■ Substances Extracted from Tag (Reference)

If chemicals penetrate into a Tag through PFA, ions may be extracted from the Tag.

■ Results of Ion-exchange Chromatography

A built-in Tag was soaked in hot water (100°C for 16 hours), and extracted ions were analyzed. The results are shown below.

Extracted Ions (Concentration)

Cl: 0.5 ppm, Na⁺: 10 ppm, NH₄⁺: 11 ppm, K⁺: 1.0 ppm

■ Results of ICP Emission Spectral Analysis

The V680-D1KP66T-SP Tag was soaked in concentrated hydrochloric acid (which can easily penetrate through PFA) at 80°C for 300 hours, then extracted substances were analyzed.

Extracted Substances (Concentration)

Si: 700 ng/ml, S: 1,000 ng/ml, Ca: 30 ng/ml



CHECK!

The chemical resistance and extracted substances presented here should be used for reference only. The rates of change in Tag characteristics and the amounts of substances extracted will vary with temperatures and chemical concentrations. Before using Tags under actual production environment, always conduct tests to check for any problems

Degree of Protection

Ingress protection degrees (IP-□□) are determined by the following tests. Be sure to check the sealing capability under the actual operating environment and conditions before actual use.

IP indicates the ingress protection symbol.

■ IEC (International Electrotechnical Commission) Standards IEC 60529: 1989-11

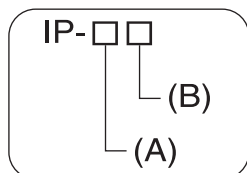









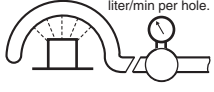

(A) First Digit: Degree of Protection from Solid Materials

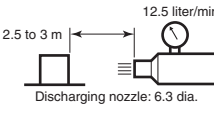
Degree	Degree	Degree
0		No protection
1		Protects against penetration of any solid object such as a hand that is 50 mm or more in diameter.
2		Protects against penetration of any solid object, such as a finger, that is 12.5 mm or more in diameter.
3		Protects against penetration of any solid object, such as a wire, that is 2.5 mm or more in diameter.
4		Protects against penetration of any solid object, such as a wire, that is 1 mm or more in diameter.
5		Protects against penetration of dust of a quantity that may cause malfunction or obstruct the safe operation of the product.
6		Protects against penetration of all dust.

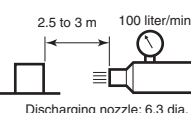
(B) Second Digit: Degree of Protection Against Water

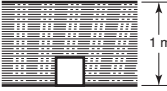
Degree	Protection	Test method (with pure water)
0	No protection Not protected against water.	No test
1	Protection against water drops 	Protects against vertical drops of water towards the product. Water is dropped vertically towards the product from the test machine for 10 min.
2	Protection against water drop 	Protects against drops of water approaching at a maximum angle of 15° to the left, right, back, and front from vertical towards the product. Water is dropped for 2.5 min each (i.e., 10 min in total) towards the product inclined 15° to the left, right, back, and front from the test machine.

Degree	Protection		Test method (with pure water)
3	Protection against sprinkled water 	Protects against sprinkled water approaching at a maximum angle of 60° from vertical towards the product.	Water is sprinkled for 10 min at a maximum angle of 60° to the left and right from vertical from the test machine.  Water rate is 0.07 liter/min per hole.
4	Protection against water spray 	Protects against water spray approaching at any angle towards the product.	Water is sprayed at any angle towards the product for 10 min from the test machine.  Water rate is 0.07 liter/min per hole.
5	Protection against water jet spray 	Protects against water jet spray approaching at any angle towards the product.	Water is jet sprayed at any angle towards the product for 1 min per square meter for at least 3 min in total from the test machine.  12.5 liter/min 2.5 to 3 m Discharging nozzle: 6.3 dia.
6	Protection against high pressure water jet spray 	Protects against high-pressure water jet spray approaching at any angle towards the product.	Water is jet sprayed at any angle towards the product for 1 min per square meter for at least 3 min in total from the test machine.  2.5 to 3 m 100 liter/min Discharging nozzle: 6.3 dia.
7	Protection underwater 	Resists the penetration of water when the product is placed underwater at specified pressure for a specified time.	The product is placed 1 m deep in water (if the product is 850 mm max. in height) for 30 min. 
8 (See Note)	Protection underwater 	Can be used continuously underwater.	The test method is determined by the manufacturer and user.

Note: OMRON Test Method

Usage conditions: 10 m or less under water in natural conditions

- 1.No water ingress after 1 hour under water at 2 atmospheres of pressure.
- 2.Communications performance must be met after 100 repetitions of 30 minutes in 5°C water and 30 minutes in 85°C water.

■ Oil resistance (OMRON in-house standard)

Protection	
Oil-resistant	No adverse affect from oil drops or oil spray approaching from any direction.
Oil-proof	Protects against penetration of oil drops or oil spray approaching from any direction.

Note: This OMRON in-house standard confirms resistance to cutting and other oils. It is equivalent to the former JEM standard.

Revision History

A manual revision code appears as a suffix to the catalog number at the bottom of the front and rear pages.

Cat. No.: Z262-E1-03

↑
Revision code

Revision code	Date	Revised contents
01	May 2007	Original production
02	July 2007	Added item for V680-HS65 Antenna, and the overseas regulations and standards.
02A	September 2007	Added information on metal on back surface of the V680-HS65, corrected Tag specifications, and made other minor corrections.
03	December 2007	Added item for V680-HS51 Antenna, V680-D1KP66T-SP Tag, the overseas regulations and standards, , and made other minor corrections.