

# **Inspur Storage System**

## **AS1100H**

User Manual v1.0

Inspur

## **Dear users of Inspur storage system:**

**Sincerely thank you for selection of Inspur storage system!**

This manual introduces the technical characteristics and system installation, setup and usage of Inspur storage system, and helps you to particularly understand and expediently use this storage system.

Please deliver the package of our product to the waste recycling station for recycling, in favor of pollution prevention and humankind's benefit.

This manual is the property of Inspur.

This User Manual is not to be copied by any group or person in any manner without the consent of Inspur. The Inspur reserves the right of revising this manual momentarily.

Any alteration about the content of this manual will not be noticed. We suggest that the user shall read this manual before using Inspur storage system, so as to avoid any mistake during operation.

Please forgive any insufficiency in details, point out and give directions for us in time. Please contact Inspur, if you have any questions or advice about this manual.

Inspur  
May. 2014

“Inspur ” is a registered trademark of the Inspur Group Co., Ltd.

Other trademarks belong to other corresponding registered companies.

## Statement

Please read the following statement before you use this storage system formally. Only when you have read this statement hereinafter and agreed the following terms, you can formally use this storage system. If you have any questions about the following terms, please contact our supplier or us directly. If you have no questions about these terms and start to use this system, it acquiesces that you have agreed *the following terms*.

1. We must call your attention that you must not alter any other parameters in the main board BIOS of this storage system at any time, except for the parameters which we promote that you can alter.

2. If there are any hardware problems when you use this storage system, or you wish to upgrade the hardware, please feed back the detail hardware configuration of your computer to our Customer Service. Don't disassemble the storage system case or any hardware components in the case by yourself.

3. Memory, CPU, board card, BBU, fan, disk tray and hard disk etc. of this storage system are of special specification; please do not use them with equipment of any other type.

4. When you have any software problems during the application of this storage system, we hope that you firstly contact the corresponding software supplier and then he will contact us in favor of communication so as to solve your problem together, especially the software problems about the database, the installation and running of the network management software or other networking products.

5. Please read quick installation guide in this manual carefully before installing this storage system. Inspur is engaged in constantly improving product function and performance, which may cause part of functions different from description in this manual, but not impact usage, if you have any doubt on usage, please contact our customer service center.

6. We must call your attention that in the application process, you should pay attention to do necessary backup of your file.

7. This is a Grade A product, and this product may induce radio jamming. In this case, users need to adopt feasible measures to the interference.

8. Please carefully read and comply with safety rules in this manual.

9. The copyrights of the markers and names of the software and hardware product referred in this manual are the property of corresponding companies.

In the above statement, "us" indicates Inspur. Inspur holds the right of final explanation about the above statement.

## Safety Rules

1. The power supply equipment in the system may generate high voltage and dangerous electrical energy and thus cause personal injury. Please do not dismount the cover of the host or to dismount and replace any component in the system by yourself, unless otherwise informed by Inspur, only maintenance technicians trained by Inspur have the right to disassemble the cover of the host, dismount and replace the internal components.

2. Please connect the equipment to appropriate power supply, and the power should be supplied by external power supply which is indicated on the rated input label. To prevent your equipment from damages caused by momentary spike or plunge of the voltage, please use relevant voltage stabilizing equipment or uninterruptible power supply equipment.

3. If extended cables are needed, please use the three-core cables matched with correct earthed plug, and check the ratings of the extended cables to make sure that the sum of rated current of all products inserted into the extended cables do not exceed 80% of the limits of the rated currents of the extended cables.

4. Please be sure to use the supplied power supply component, such as power lines, power socket (if supplied with the equipment) etc. For the safety of equipment and the user, do not replace randomly power cables or plugs.

5. To prevent electric shock dangers caused by leakage in the system, please make sure that the power cables of the system and peripheral equipment are correctly connected to the earthed power socket. Please connect the three-core power line plug to the three-core AC power socket that is well earthed and easy to access, be sure to use the earthing pin of power lines and do not use the patch plug or the earthing pin unplugged with cables. In case of the earthing conductors not installed and it is uncertain whether there are appropriate earthing protections, please do not operate or use the equipment. Contact and consult with the electrician.

6. To avoid short circuit of internal components and fire or electric shock hazards, please do not fill any object into the open pores of the system.

7. Please place the system far away from the cooling plate and at the place with heat sources, and be sure not to block the air vents.

8. Be sure not to scatter food or liquid in the system or on other components, and do not use the product in humid and dusty environment.

9. The replacement of batteries with those of another models may cause explosion. When replacement of batteries is required, please consult first the manufacturer and choose batteries of the same or a similar model recommended by the manufacturer. Do not dismount, extrude and pink the batteries or make the external connection point short circuit, and do not expose them in the environment over 60°C. Never throw them into fire or water. Please do not try to open or repair the batteries, and be sure to reasonably deal with the flat batteries and do not put the exhausted batteries, the circuit boards that may include the batteries and other components with other wastes. For relevant battery recovery, please contact the local waste recovery and treatment mechanism.

# Contents

Statement.....	3
Chapter I Installation Preparations.....	8
1.1 Key terminology.....	8
1.2 Necessary parts.....	8
1.3 Hardware overview.....	9
Chapter II Install HBA Card.....	12
2.1 Key terminology.....	12
2.2 Notes for installing HBA cards.....	12
2.3 Install HBA card.....	12
Chapter III Configure Switches.....	13
Chapter IV Quick Installation Guide.....	14
4.1 Cabinet preparation.....	14
4.2 Storage system guide rail suite.....	14
4.3 Install guide rail to cabinet.....	15
4.4 Install the equipment into cabinet.....	17
Chapter V Connect Controller and Host.....	19
5.1 Key terminology.....	19
5.2 Host connection notes.....	19
5.3 Steps to connect host.....	20
5.4 Host channel connection topology.....	20
5.4.1 Direct connection topology.....	20
5.4.2 Switch connection topology.....	21
5.4.3 Mixed connection topology.....	21
5.5 Management method topology.....	22
5.5.1 In-band management.....	22
5.5.2 Out-of-band management.....	23
Chapter VI Connect Extension Cabinet.....	24
6.1 Key terminology.....	24
6.2 Connection notes.....	24
6.2.1 Disk channels.....	24
6.2.2 Extension cabinet connection notes.....	24
6.3 Extension cabinet connection steps.....	25
6.4 Disk array extension illustration.....	25
Chapter VII Connect Power Supply.....	28
7.1 Power line connection notes.....	28
7.2 Power line connection steps.....	28
Chapter VIII System Power-on and Check.....	29
8.1 System power-on steps.....	29

8.2 Disk array indicator description .....	29
8.3 Part repair indicator .....	30
Chapter IX Install Storage Management Software .....	31
9.1 Key terminology .....	31
9.2 Installation introduction .....	31
9.3 Operating system special introduction .....	31
9.4 Installation environment requirement .....	32
9.5 Disk space requirement .....	33
9.6 Software installation steps .....	33
9.7 STRMGR management software module introduction .....	33
9.8 Software module selection reference .....	34
9.9 Install RDAC under Linux .....	34
Chapter X Configure HBA Cards .....	35
10.1 Configure HBA Cards in Windows Server 2003 .....	35
10.2 Configure HBA Cards in Windows Server 2008 .....	35
10.3 Configure HBA cards in Linux .....	35
Chapter XI Start Management Software .....	36
11.1 Management software startup .....	36
11.2 Enterprise Management Window (EMW) and Array Management Window (AMW) .....	36
Chapter XII Add a Storage Array .....	38
Chapter XIII Name the Storage Array .....	39
13.1 Naming notes .....	39
13.2 Naming steps .....	39
Chapter XIV Troubleshooting .....	40
Chapter XV Configure Controllers Manually .....	41
15.1 Configuration notes .....	41
15.2 Configuration steps .....	41
Chapter XVI Set a Password .....	43
16.1 Password setting notes .....	43
16.2 Password setting steps .....	43
Chapter XVII Configure Email and SNMP Alarm .....	44
17.1 Configuration notes .....	44
17.2 Alert notification configuration steps .....	44
17.3 Mail server tab .....	44
17.4 Email tab .....	44
17.5 SNMP tab .....	45
Chapter XVIII Cache Setting .....	46
18.1 Cache setting notes .....	46
18.2 Modify cache setting .....	46

18.3 Modify volume cache setting .....	47
Chapter XIX Add a Host .....	48
19.1 Key terminology .....	48
19.2 Adding host notes .....	48
19.3 Define a host group .....	48
19.4 Storage partition usage notes .....	48
19.5 Adding a host steps .....	50
Chapter XX Configure Storage System .....	51
20.1 Key terminology .....	51
20.2 Capacity allocating notes .....	51
20.3 Volume group, DDP and volume creating notes .....	52
20.4 Host to volume mapping and storage partition notes .....	52
20.5 Hot spare disk usage notes .....	52
20.6 Storage configuration steps .....	52
Hazardous Substances or Elements Name and Content Table – Storage System .....	54

# Chapter I Installation Preparations

This chapter mainly describes preparations for installing AS1100H storage system.

## 1.1 Key terminology

### **Controller main cabinet**

Controller main cabinet contains one or two controllers, power modules and fan modules etc., controller main cabinet provides interfaces for storage disk arrays and the host, and 12 hard disks could be inserted into controller main cabinet.

### **Extension cabinet**

Hard disks could be installed into extension cabinet, not including controller, it contains environment services monitor (ESM), power module and fan module etc. Extension cabinet is usually connected to the back of controller main cabinet, and could be connected to other extension cabinets, so as to meet expansion of disk array volume.

### **SFP**

SFP is a kind of equipment communicating with fiber optical equipment, SFP could be used on HBA cards and controllers.

## 1.2 Necessary parts

Hardware	
Cabinet	Make sure cabinet complies with AS1100H specification, and power supply could provide sufficient power.
Guide rail support and screws	Used for installation of storage AS1100H.
Cables	
Power lines	Power lines installed together with storage could be used to connect an external power supply, if your cabinet is equipped with special power lines, these could be replaced.
Optical fiber lines	Use optical fiber lines to connect storage arrays and the host or optical switches.
Ethernet cables	Used to connect storage arrays to carry out out-of-band management.
Other tools	
Screwdrivers	One slotted screwdriver and one Phillips screwdriver.
Antistatic equipment	To avoid static damages.
Label paper	Used to mark positions.



### 1.3 Hardware overview

Front view of AS1100H (12 hard disks configuration) is as shown in the following Figure 1-1.

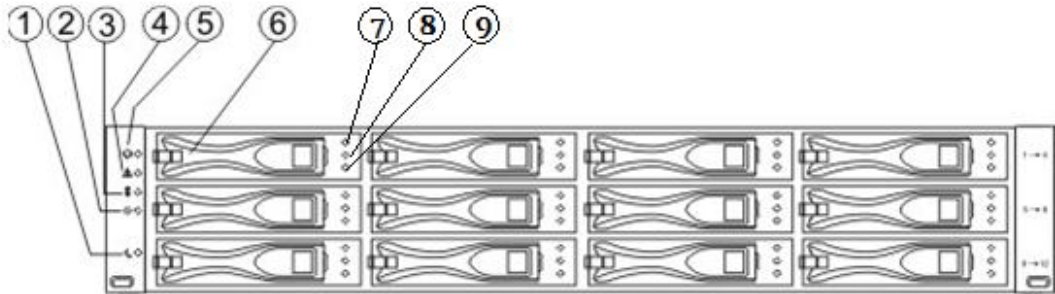

Figure 1-1 Front View of AS1100H

Hard disk sequence, the first row (1-4), the second row (5-8), the third row (9-12).

Number	Name	Number	Name
1	Backup power indicator	6	Disk driver module
2	Power indicator	7	Maintainable
3	Temperature alarm indicator	8	Disk fault indicator
4	Service operation indicator	9	Disk power indicator
5	Position indicator		

Front view of AS1100H (24 hard disks configuration) is as shown in the following Figure 1-2.

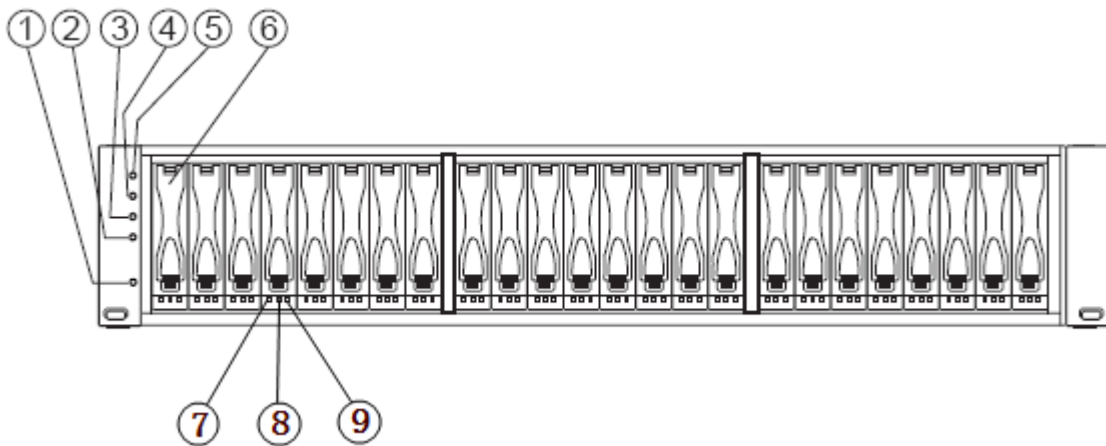

Figure 1-2 Front View of AS1100H

Hard disk sequence, 1 to 24.

Number	Name	Number	Name
1	Backup power indicator	6	Disk drive module

2	Power indicator	7	Maintainable
3	Temperature alarm indicator	8	Disk fault indicator
4	Service operation indicator	9	Disk power indicator
5	Position indicator		

Rear view of AS1100H (configured with SAS HIC card) is as shown in the following Figure 1-3:

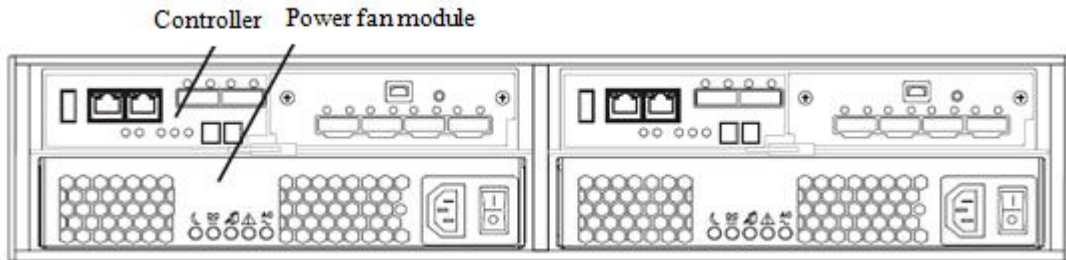
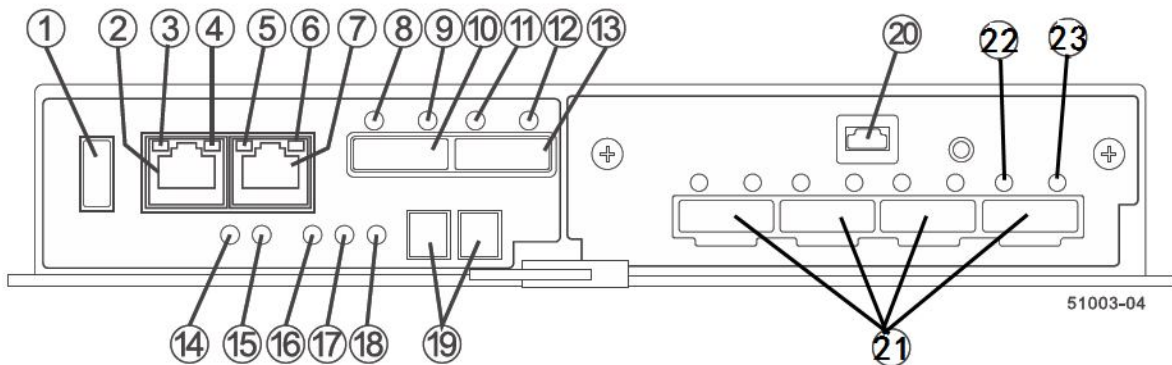

Figure 1-3 Rear View of AS1100H

AS1100H controller (configured with SAS HIC card) is as shown in the following figure:



Number	Name	Number	Name
1	USB interface	13	SAS (SFF-8088) extension interface 2
2	Network interface 1	14	Backup power indicator
3	Network connection fault indicator	15	DC power indicator
4	Network interface connection indicator	16	Power fan module permit maintenance indicator
5	Network connection fault indicator	17	Power fan module alarm indicator
6	Network interface connection indicator	18	AC power indicator
7	Network interface 2	19	DC power indicator seven-segment digital display
8	SAS extension connection fault	20	Serial interface

	indicator		
9	SAS extension connection indicator	21	HIC card host channel interface
10	SAS (SFF-8088) extension interface 1	22	SAS host channel connection fault indicator
11	SAS extension connection fault indicator	23	SAS host channel connection indicator
12	SAS extension connection indicator		

The rear view of AS1100H may be different on host interface types because of different HIC cards.

# Chapter II Install HBA Card

## 2.1 Key terminology

### **HBA card (host bus adapter)**

Host bus adapter, physical card installed on the host, providing data IO transmission between the host and storage controller.

### **Host port of HBA card**

Physical and electrical interface in the host for HBA card to connect storage, most HBA cards have one or two host ports. Each HBA card has a unique WWID number, and host port of each HBA card has a unique WWID number.

## 2.2 Notes for installing HBA cards

Host channel of AS1100H is FC, and FC HBA card needs to be used on the host, while FC switch needs to be used on switch, and the speed shall match either.

In order to provide the maximum hardware redundancy, 2 HBA cards need to be installed on one host, and doubleport HBA card provides 2 host ports, rather than redundancy feature.

In order to achieve the maximum performance, it is better to use 16Gb storage host channel with a 16Gb HBA card, if an 8Gb HBA card is used, data transmission rate will be kept at 8Gb.

When host operating system is VMware, mixed connection will not be supported in one partition.

Windows operating system does not support mixed connection in one partition, when a host uses multiple partitions to connect the same storage array, no repeated lun number shall be used.

Mixed connection from a host to a storage array is not supported by other operating systems.

## 2.3 Install HBA card

1. Make sure the HBA card in use is compatible with storage.
2. Install HBA cards according to documents provided by manufacturer.
3. Restart the host.
4. During self-checking of the host, pay attention to prompt messages about entering HBA card BIOS, enter HBA card BIOS according to these messages.
5. Record the following information: Host name, HBA card on the host, host port WWID on each HBA card.

## Chapter III Configure Switches

This chapter briefly introduces the configuration and use of switches.

1. Make sure the switch in use is compatible with this storage array.
2. Install the switch according to documents provided by switch manufacturer.
3. Visit website of optical switch manufacturer, obtain the latest Firmware and management software, and update optical switch Firmware, you may need to shut down the switch to restart.
4. If a Brocade or Cisco optical switch is used, it is required to use configuration management of the switcher to open IOD (In-Order Delivery) option.
5. According to your needs, you can divide zone of the switch under the direction of engineer.
6. For more instructions, please consult the switch manufacturer.

## Chapter IV Quick Installation Guide

This part mainly introduces quick installation of the equipment, according to the following description, you could complete installation of the equipment in the shortest time, in the safest way.



### Note

---

**Threaten brought by static electricity** – Static electricity is a fatal threaten to electronic equipment, for static electricity may puncture some electronic parts, causing failure of the whole equipment, and bringing along huge losses unconsciously. So, during operation on equipment, make sure to carry out electrostatic protection, which will not be noted in the following sections.

---

### 4.1 Cabinet preparation

**Cabinet leveling:** Cabinet must be placed firmly, adjust four legs at the bottom, make the cabinet be placed on the ground firmly. Meanwhile, dismantle cabinet door and side panel for guide rail installation.

**Cabinet grounding:** In order to avoid electric shock risk, it is required to install an earthing device inside the cabinet. If power line of this equipment is inserted into power socket as part of the cabinet, proper earthing must be provided for the cabinet. If power line of storage system is inserted into power socket on the wall, earthing device inside power socket only provides earthing for this equipment, it is required to provide proper earthing protection for the cabinet as well as other equipment inside it. It is suggested that you shall use the cabinet specially designed for Inspur storage system. If you're using an Inspur storage cabinet, and all parts inside the cabinet are grounded, Please do not change any of earthing connections inside the cabinet.





**Temperature:** If storage equipment is installed inside the cabinet, operating and working temperature of storage system shall not be lower than 5°C, nor higher than 35°C.

**Ventilation:** Cabinet used by storage equipment shall provide sufficient wind flow for front and rear parts of the system, and shall guarantee a 4100Btu heat discharge per hour, while above 1m space shall also be kept in front and rear.

### 4.2 Storage system guide rail suite

Articles contained in guide rail suite for this equipment are as shown in Table 4-1.

Table 4-1 Guide Rail Suite

Illustration	Description
	<p>L type guide rail (one piece on left and right)</p> <ul style="list-style-type: none"> <li>● This guide rail adopts the design of rear-hang, flexible probe and free of nuts, greatly simplifying installation process.</li> <li>● This guide rail applies to installation of 2U, 3U and 4U equipment, and can reach a 65kg bearing.</li> </ul>
	<p>Front position columns (2 for each, 4 in all)</p> <ul style="list-style-type: none"> <li>● Usually attached to the front rail.</li> <li>● Fix the position column on front rail, install it into the angle rail hole, to undertake gravity.</li> </ul>
	<p>Round head screws (M5×6, 2 screws for each, 4 screws in all)</p> <ul style="list-style-type: none"> <li>● Usually 1 screw is attached to front and rear rail respectively.</li> <li>● During usage, fix guide rail onto angle rail, to fix and undertake gravity.</li> </ul>
	<p>Crown screws (M5×16, 1 screws for each, 2 screws in all)</p> <ul style="list-style-type: none"> <li>● Usually attached to the front rail.</li> <li>● During usage, fix screws onto angle rail, to fix and avoid falloff.</li> </ul>

### 4.3 Install guide rail to cabinet

1. Length of front and rear rail could extend freely when pulled, in order to guarantee guide rail bearing, a certain friction is required during extension, otherwise, both front and rear rails will become too loose; on the contrary, if too tight, front and rear rails will not be able to extend, it is required to loosen four turnbuckle screws as shown in Figure 4-1 according to situation.

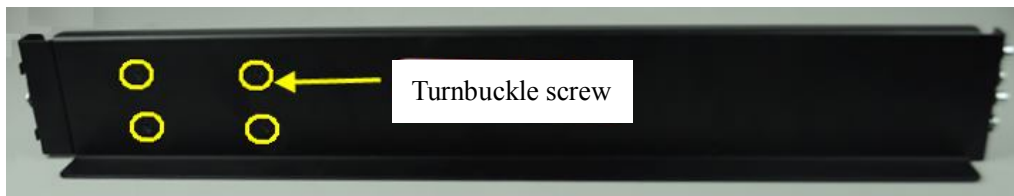

Figure 4-1

2. Extend front and rear guide rails, to make its length equivalent to front and rear distance of cabinet angle rail.

3. Confirm installation position of the equipment, generally, a height scale is marked on cabinet angle rail, and introduction will be given in below taking 32U position installation as an example.

4. On rear guide rail, there're two connectors, align the lower connector with the

second hole above the starting point of 32U scale on angle rail, the upper connector with the second hole above the starting point of 33U scale, insert the connector through the hole, and then press it down, to connect it to angle rail, now L-shaped part of guide rail shall be leveled with the starting point of 32U scale, and rear rail fixing holes shall display in the center of the third hole above the starting point of 32U, as shown in Figure 4-2.

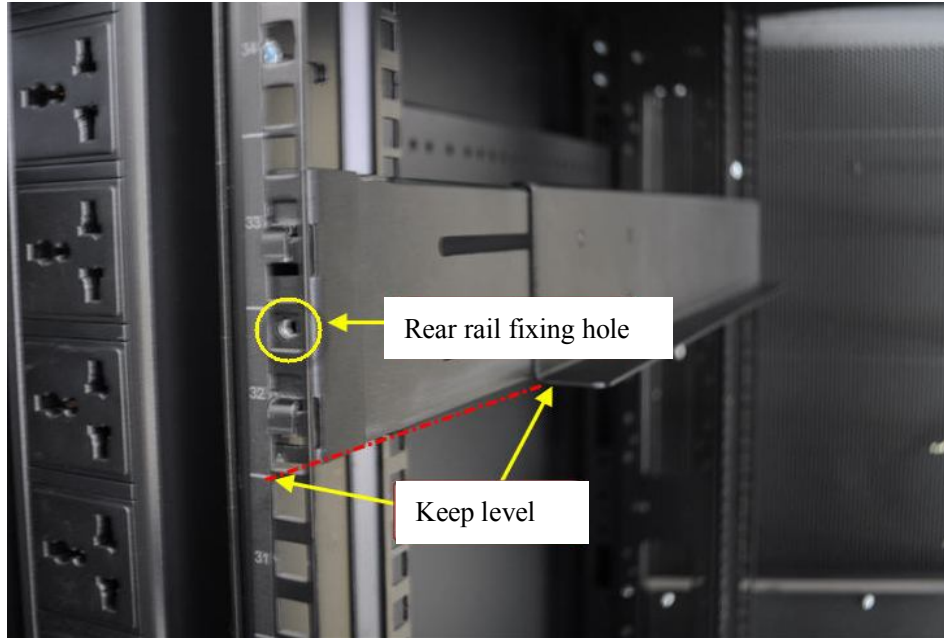

Figure 4-2

5. Adopt guide rail standard configuration of M5×6 round head screws, screw in rear rail fixing holes, to fix guide rail.

6. Adjust fixing positions of two fixing columns of front guide rail as required, so as to leave corresponding positions for front fixing holes of the equipment, place guide rail to a horizontal position, align lower edge with 32U starting point, extend fixing columns into angle rail fixing holes, and fix them with round head M5×6 screws, as shown in Figure 4-3, while fixing positions of round head M5×6 screws are also required to be ascertained according to corresponding positions of front fixing holes of the equipment, so as to avoid.



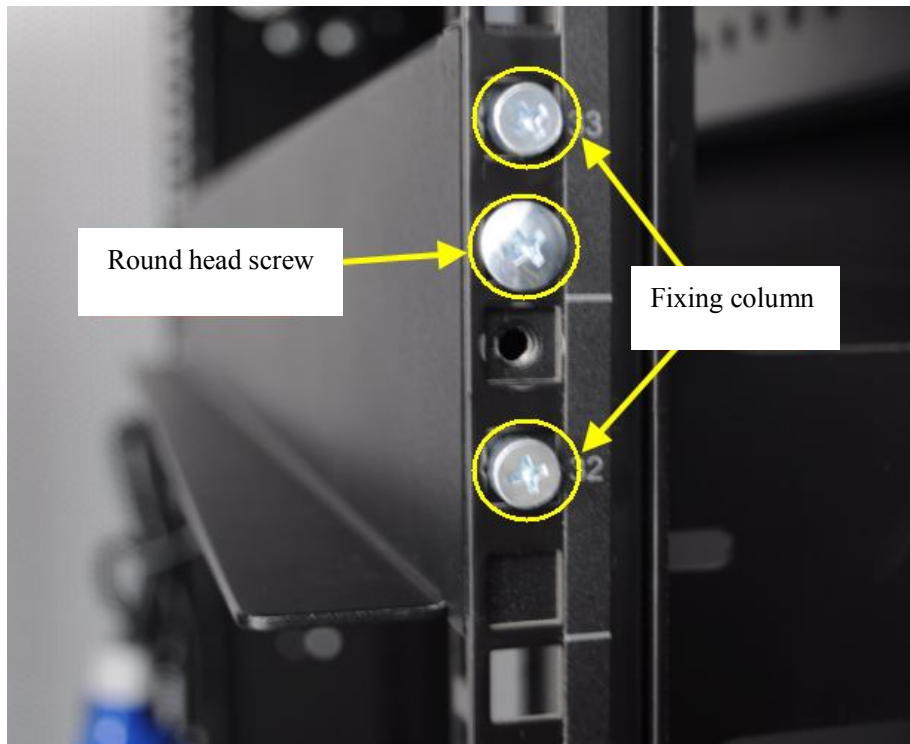

Figure 4-3

7. Fasten four fixing screws between front and rear rails.

8. Install guide rail on the other side of the cabinet, according to the above steps, be noted that guide rails on both sides shall be leveled, that is on the same height.

#### 4.4 Install the equipment into cabinet

**Note:**

- For storage equipment is heavy, in order to guarantee safety, when installing storage equipment into the cabinet, at least 4 persons are needed to move the storage system.
1. Lift the storage equipment, make it close to guide rail, and align lower angles on both sides in front of the storage system, with angles of L-shaped rails on left and right sides.
  2. To keep the storage system leveled, place the front of storage system on L-shaped guide rail (now persons in the front shall support it to guarantee safety), push it into the cabinet steadily, after entering about 1/3, the number of persons could be reduced to two, finally, push the equipment into the cabinet completely, as shown in Figure 4-4.

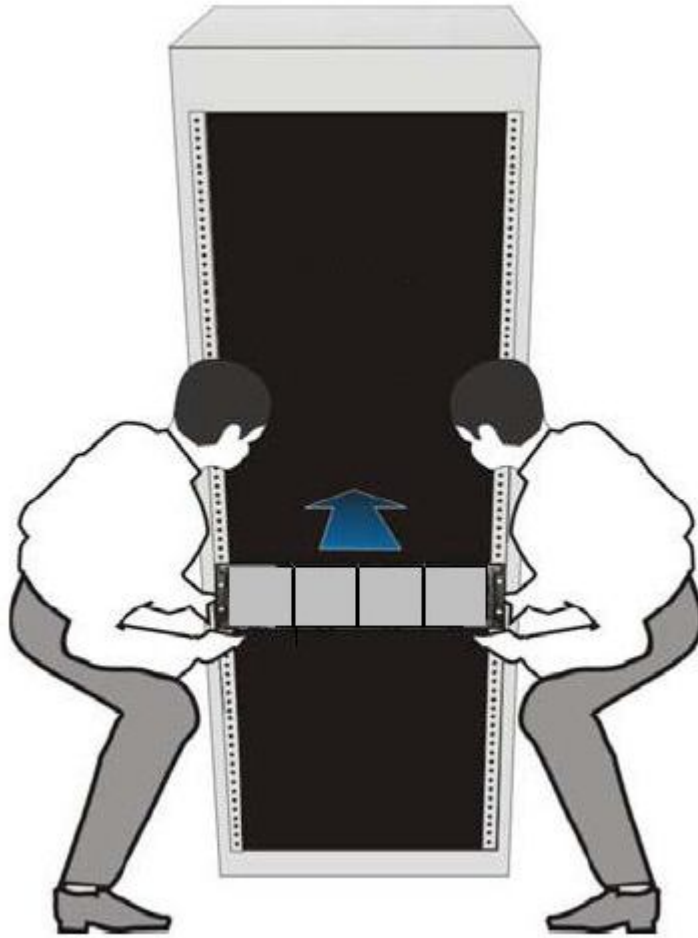

Figure 4-4

3. Adopt M5-16 crown screws, and fix storage system into the cabinet, via fixing holes on ears in front of the chassis.
4. Fix ears on both left and right panels onto both sides in front of the chassis.
5. 24 hard disks configuration: Install hard disks according to the sequence of from left to right as shown in figure 4-5; 12 hard disks configuration: install hard disks from the top row, from left to right, and then the second row, from left to right, and the bottom row, from left to right.



Figure 4-5 24 hard disks configuration hard disk installation

## Chapter V Connect Controller and Host

### 5.1 Key terminology

#### **Access volume**

A special volume, used to manage communication between the host and storage. Access volume is only used for in-band management.

#### **Switch structure and direct connection**

The way of using an optical switch to connect disk array and host is called a switch structure, while direct connection means to connect without switch, server or disk array.

#### **In-band management**

A storage management method, under which management host uses data transmission channel to transfer management commands and information.

#### **Out-of-band management**

Use Ethernet network to connect storage, and manage storage array.

### 5.2 Host connection notes

#### **Host channel**

HIC card of each controller decides the quantity and kinds of host channels. The following Figure 5-1 is the illustration of the 4 SAS host channels of each controller.

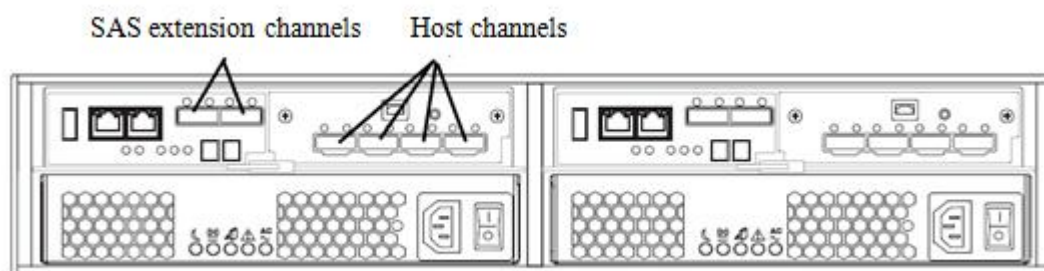

Figure 5-1 Host Channels and Host Interface Card Illustration

#### **Notes:**

1. Do not dismantle or take out any part of SFP on host channel, you may be exposed to laser radiation.
2. Static discharge may damage sensitive components, in order to avoid damaging the equipment, please adopt proper anti-static protective measures while handling any part.

#### **Host interface cards**

AS1100H host channel is realized through host interface cards (HIC), as shown in the above figure 5-1, according to product configuration, HIC card can be FC HIC card, iSCSI HIC card, SAS HIC card and IB HIC card.

FC HIC cards (4 16Gb FC channels), if using an 8Gb FC HBA card to connect a 16Gb FC

HIC card, data transmission rate will be at 8Gb/s.

- iSCSI HIC cards (2 10Gb iSCSI channels);
- SAS HIC cards (4 6Gb SAS SFF-8644 channels);
- IB HIC cards (2 40Gb IB channels).

### 5.3 Steps to connect host

1. If host is FC interface, first confirm there's an SFP module inserted in host channel, and plug off the black plastic plug on SFP.

2. As for FC host channel, insert one end of fiber-optic cable into SFP interface of host channel.

3. Insert the other end of the cable into corresponding host FC HBA card/network card or switch, and guarantee the rate matches with protocol.

4. It is suggested to label both ends of the cable, which is very important for you when disconnect the cable and carry out operation on controller.

Suggested label content includes: Hostname and HBA card ports, controller ID (i.e. controller A), host channel ID (i.e. host channel 1).

Label writing example: i.e. a cable is used to connect No. 1 port in No. 1 HBA card of a host named Jinan with No. 1 host channel of controller A, and label could be abbreviated according to the following: Jinan-HBA1/P1,CtA-Hch1

5. Repeat these steps to connect all host channels to be used.

### 5.4 Host channel connection topology

#### 5.4.1 Direct connection topology

2 hosts are directly connected to a dual-controller disk array.

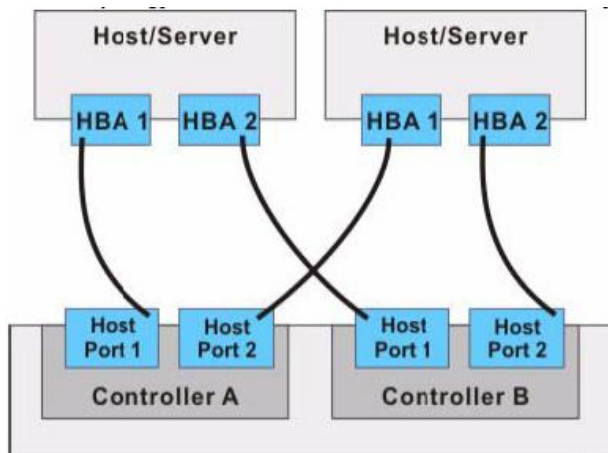

Figure 5-2 Direct Connection Topology

## 5.4.2 Switch connection topology

1 host is connected to dual-controller storage disk array via switch.

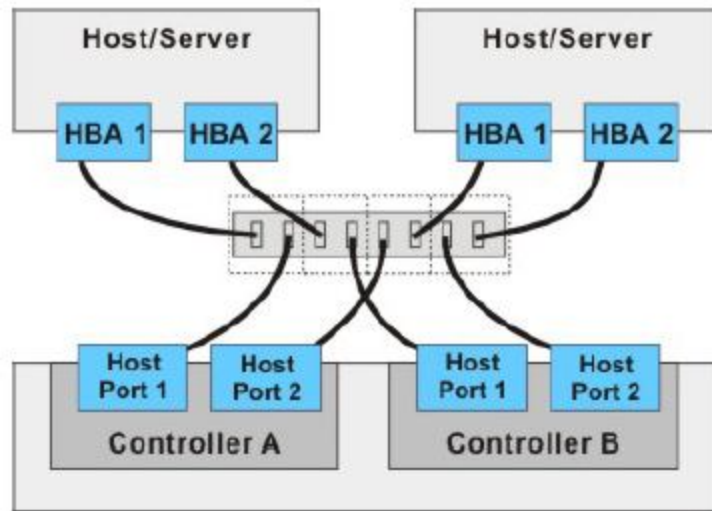

Figure 5-3 Switch Connection Topology

## 5.4.3 Mixed connection topology

3 hosts are connected to a dual-controller storage array via 2 switches.

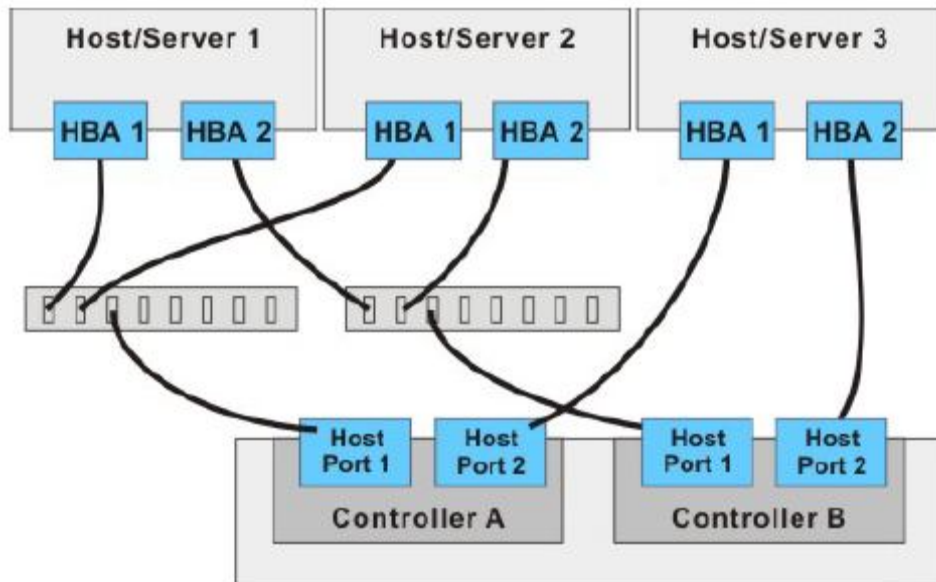

Figure 5-4 Mixed Connection Topology

Note: Host channel with the highest number is reserved for remote volume mirroring, to enable this function, do not use the host channel with the highest number.

## 5.5 Management method topology

### 5.5.1 In-band management

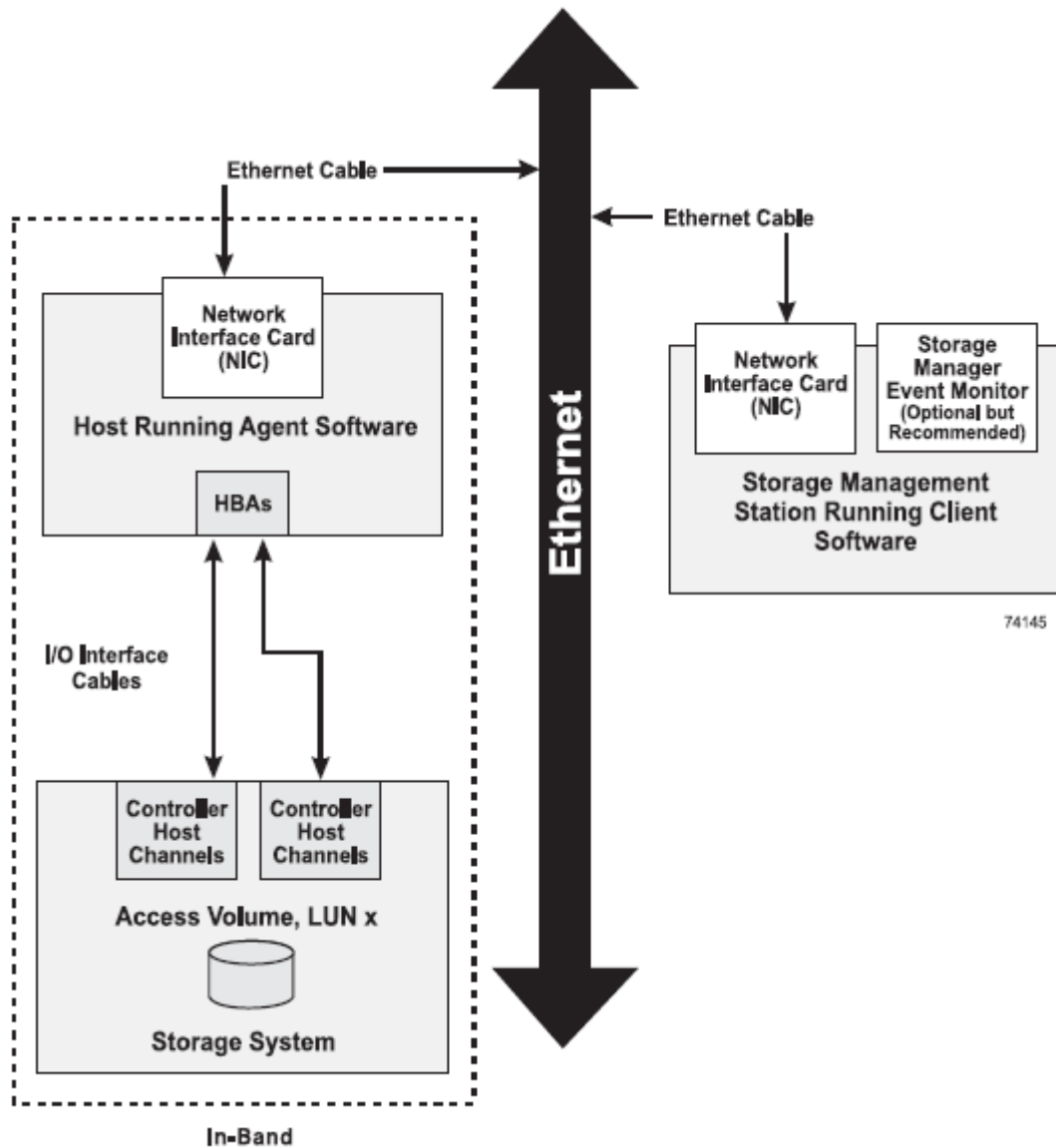

Figure 5-5 In-band Management

In-band management does not need management port of the controller to connect network cable, but needs to install host-agent software, and map access volume to the host, so that the host could communicate with storage via access volume. This method occupies a part of data bandwidth.

## 5.5.2 Out-of-band management

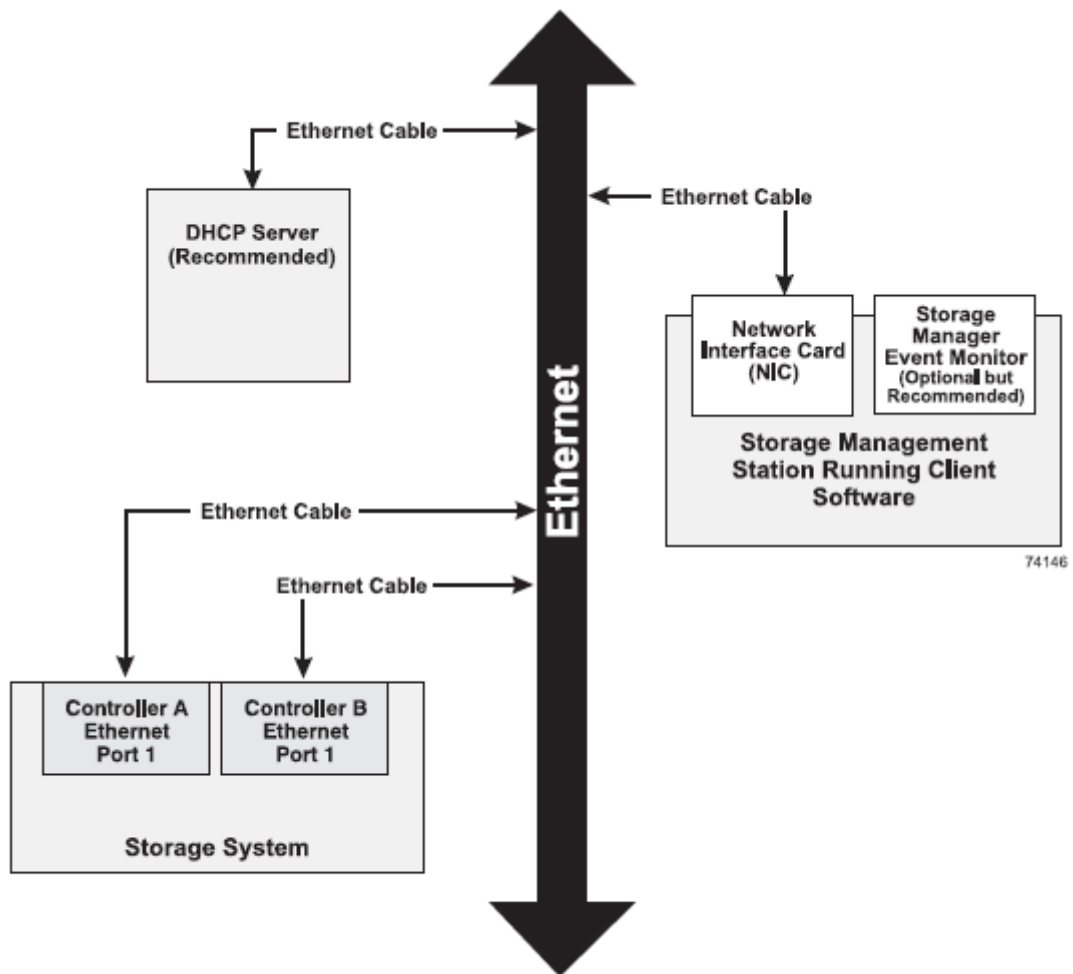

Figure 5-6 Out-of-band Management

Out-of-band management needs not to use access volume, but to connect both controllers to management network, and default IP addresses of two controllers are 192.168.128.101 and 192.168.128.102.

# Chapter VI Connect Extension Cabinet

## 6.1 Key terminology

### Disk channels

Channels used to transmit data between controller and extension cabinet of disk array.

### ESM(environmental services monitor)

Environment services monitor, a module monitoring part status inside extension cabinet, which also plays a role of connection, transmitting data between extension cabinet and disk array controller, and each extension cabinet has two ESM modules.

## 6.2 Connection notes

### 6.2.1 Disk channels

Each controller has 2 SAS(SFF-8644) disk extension channels, as shown in the following Figure 6-1 AS1100H Disk Extension Channel Illustration.

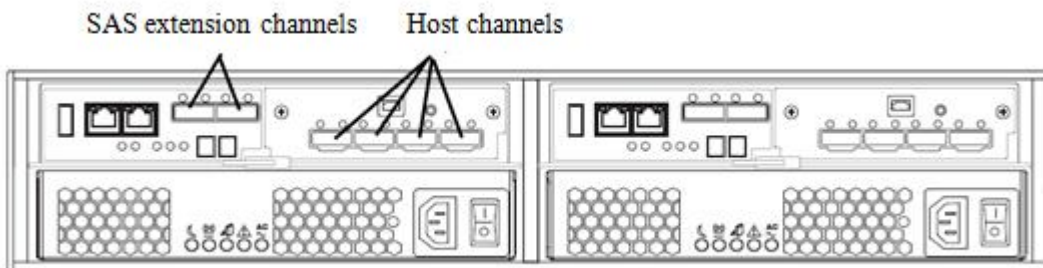

Figure 6-1 AS1100H Disk Extension Channel Illustration

### 6.2.2 Extension cabinet connection notes

Extension cabinet connected to AS1100H (each ESM module) contains two input ports and one output port. The following Figure 6-2 is rear view of 2U extension cabinet. The input port and output port of this extension cabinet are SAS(SFF-8088) port.

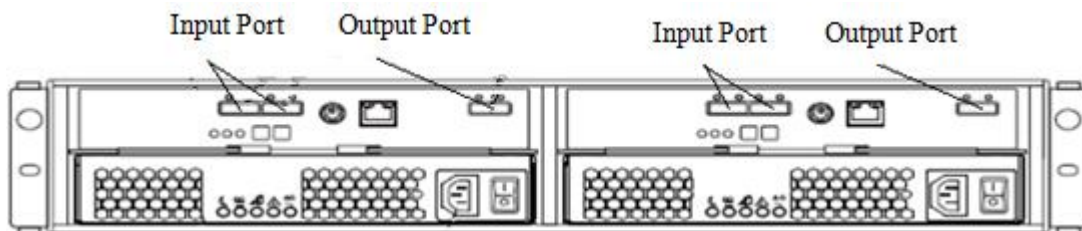

Figure 6-2 Rear View of Extension Cabinet



### 6.3 Extension cabinet connection steps

1. Insert one end of an SAS cable into disk extension channel port of disk array controller, and insert the other end into corresponding ESM disk channel I/O port.

2. To carry out maintenance on controller via disconnecting SAS cable, label is very important, it is suggested to adopt the following method to add a label to both ends of fiber-optic cable: Controller ID (i.e. controller A), disk channel ID and port ID (i.e. drive channel 1, port 4), ESM ID (i.e. ESM A), extension cabinet ID, label abbreviation such as: Connect No. 2 port of No. 1 disk channel of controller A with output port 1B of left ESM (A) in the first extension cabinet of No. 2 port of No. 1 disk channel, and the label is: CtA-Dch1/P2, Dm1-ESM\_A(left), 1B.

3. Repeat the above steps to connect disk channels of each controller in use.

### 6.4 Disk array extension illustration

Connect 1 extension cabinet

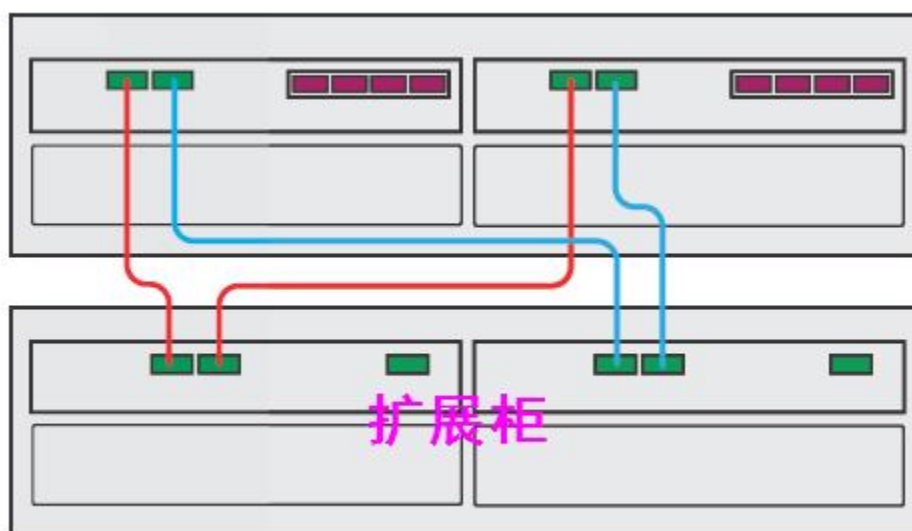
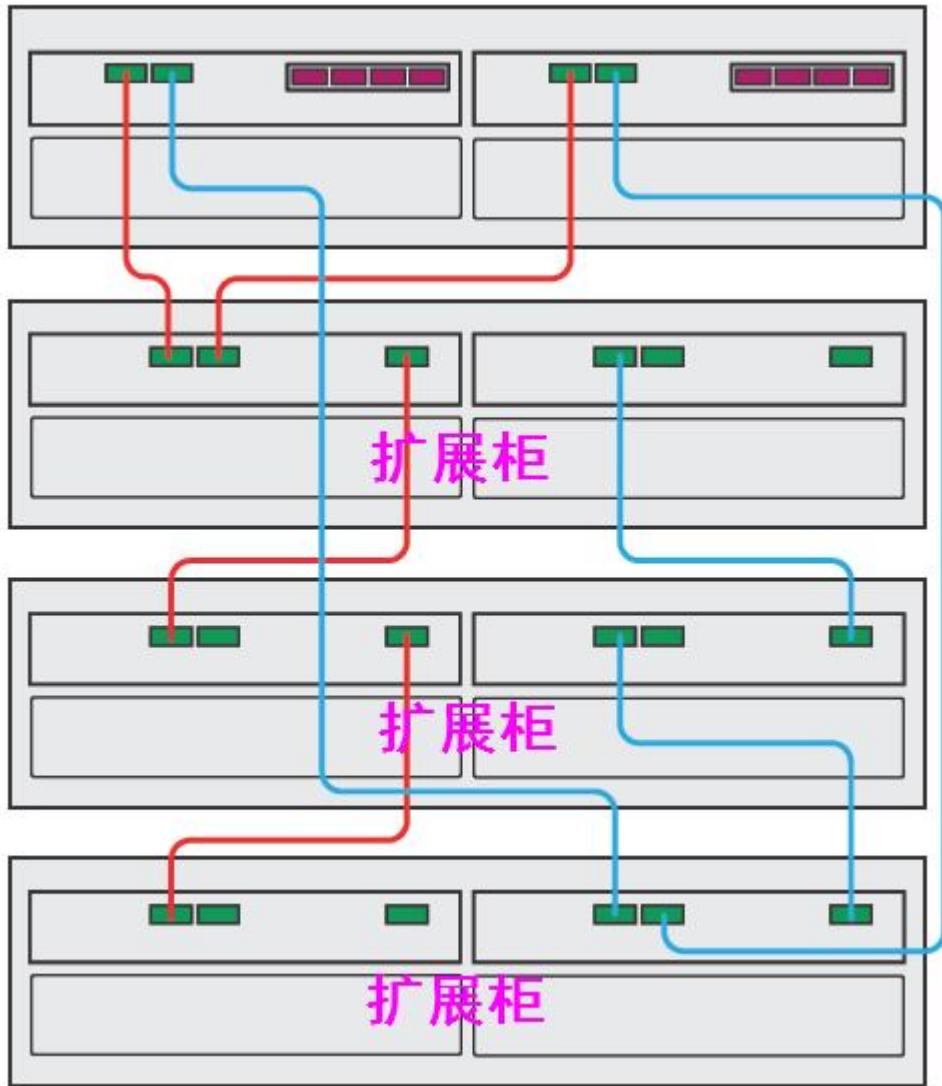

Figure 6-3 Connect 1 Extension Cabinet

Connect 3 extension cabinets



74198-02

Figure 6-4 Connect 3 Extension Cabinets  
Connect multiple extension cabinets

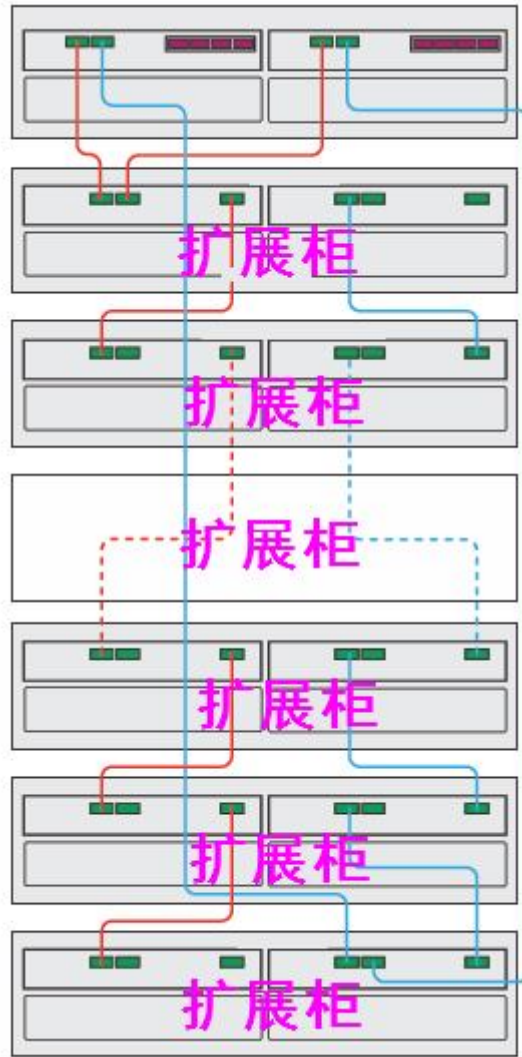

Figure 6-5 Connect Multiple Extension Cabinets

## Chapter VII Connect Power Supply

### 7.1 Power line connection notes

1. For each power supply on disk array, it is recommended to use different power inputs inside the cabinet, and independent two power inputs could guarantee power redundancy.
2. Power line equipped with disk array shall meet standards required by safety regulations of the nation, and could connect sockets or UPS directly.

### 7.2 Power line connection steps

1. Guarantee all power switches on disk array and all power switches of extension cabinet connected to it are turned off.
2. Connect power line from the cabinet to disk array or sockets on extension cabinet power module.
3. Connect main power line of the cabinet to an external power supply.







## Chapter VIII System Power-on and Check

### 8.1 System power-on steps

**Notes:**

1. Before enabling disk array, it is required to connect power supply of all connected extension cabinets, so as to guarantee the controller could recognize all connected extension cabinets.
2. Wait at least 30 seconds to power on the main cabinet after enabling extension cabinet.
3. When storage array (main cabinet or extension cabinet) is connected to power supply, front and rear indicators of storage array will flash intermittently.
4. Turn on all power switches on all extension cabinets connected to disk array.
5. Turn on two power switches of the main cabinet, according to different system configurations, a complete system startup may need several minutes.
6. Check front and rear indicators of the main cabinet and extension cabinet, if there's any yellow indicator, record its position.

### 8.2 Disk array indicator description

Indicator	Signal	Position	Function
Power Supply		Left front panel	Chassis panel On - The module is electrified Off - The module is not electrified
Temperature alarm		Left front panel	On - Temperature over high Off - Temperature normal
Backup power indicator		Left front panel	On - Power backup status Off - Power balanced status
Fault indicator		Left front panel	On - Part fault
Disk array positioning		Left front panel	On - Help to position part or storage array location
Host channel speed		Controller	Host channel speed indicator Left indicator on - 2Gb/s Right indicator on - 4Gb/s Both left and right indicators on - 8Gb/s
Cache activity		Controller	Displays cache activities Flash - Data in cache Off - No data in cache.

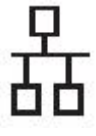
Box symbol/diagnosis display		Controller	Displays box symbol or diagnosis code
Ethernet		Controller	<p>Left indicator symbols connection rate</p> <p>Right indicator symbols connection status</p> <p>Left indicator on - 1000MB/s</p> <p>Left indicator off - 100MB/s or 10MB/s</p> <p>Right indicator on - Connection established</p> <p>Right indicator off - No connection is established</p> <p>Flash activity</p>

#### Diagnosis code and description

L0	Not matched controller type
L1	Internal battery interconnection module lost
L2	Permanent memory error
L3	Permanent hardware error
L4	Permanent data protection error
L5	Automatic code synchronization (ACS) failure
L6	Not supported host interface cards
L7	Subtype symbol not set or not matched
L8	Memory setting error
L9	Connection speed not matched
LB	Host card configuration error
LC	Memory setting error
LD	Memory mixed DIMM
LE	Memory issue
LF	Limited SYMBOL lock
LH	Controller firmware not matched

### 8.3 Part repair indicator

There's a green permitting part repair indicator in each power fan module, controller module and internal battery interconnection module, which instructs operators to dismantle parts in a safe way (dismantling parts before part repair indicator is on may cause data loss).

Part repair indicator may light up or off automatically with situation change, under most circumstances, permitting repair indicator only lights up when a certain part fails and fault indicator is on, if fault indicator is on but permitting repair indicator is off, it may need to repair other parts first, please check storage management software to decide measures to be adopted.

# Chapter IX Install Storage Management Software

## 9.1 Key terminology

### **RDAC (redundant dual active controller multi-path driver)**

In order to configure IO transmission driver of disk array management data of redundancy controller. If a certain part connecting storage array fails, causing communication between the host and controller lost, this driver will relocate all IO paths automatically, and switch to another controller of storage array if necessary.

### **Host**

Connects to storage array, and accesses volume on storage array via host ports on HBA cards.

### **Management workstation**

Runs computer of storage management software, used to add, monitor and manage storage arrays on network.

## 9.2 Installation introduction

This introduction is used to install installation wizard of STRMGR management software, and independent installation software packages of various operating systems are provided in CD.

Storage management software supports windows 2003, 2008 operating systems and Linux operating system.

## 9.3 Operating system special introduction

### **Windows XP, Windows 7 and Windows Vista:**

These 3 operating systems only support STRMGR client, rather than other software packages such as RDAC multipath software, STRMGR installed on these two systems could only be used as a storage management workstation, and does not support VDS, VSS of Microsoft, nor SMI of SINA.

### **Windows server 2003 and Windows server 2008:**

When RDAC driver is not installed, an error message prompts after installation is done, indicating if there're several alarming notices after installation, it is suggested to view installation log to understand detailed situation, and installation log includes win32 abnormal warnings, which is normal, and the installation process is successful.

### **Linux Red Hed 5 Client and SUSE desktop 10:**

Only STRMGR client software package is supported, while other software packages such as RDAC multipath software are not supported, and STRMGR installed on these two systems could only be used as a storage management workstation.

### **Red Hat Enterprise Linux and SUSE Linux Enterprise Server:**

These two operating systems support RDAC multipath software, as well as SteelEye

LifeKeeper, Novell Open Enterprise Server (OES) and Native Red Hat Clustering software.  
(RHLE 4 does not support SteelEye LifeKeeper under IA64 architecture)

## 9.4 Installation environment requirement

<b>Operating system</b>	<b>System Edition</b>	
<b>Windows XP</b>	x86-based system (32-bit and 64-bit) Pentium or greater CPU or equivalent (233 MHz minimum) Professional Service Pack 2 (SP2) or later <b>Note:</b> Only storage management workstation is supported.	
<b>Windows server 2003</b>	x86-based system (IA32, Intel Xeon, and 32-bit or 64-bit AMD Opteron) IA64 Standard Edition, Enterprise Edition, SP 2 SP 1 or x64 Edition (64-bit x86-based system only)	
<b>Windows Vista</b>	x86-based system (32-bit and 64-bit) Pentium or greater CPU or equivalent (800 MHz minimum) Business Edition or higher <b>Note:</b> Only storage management workstation is supported.	
<b>Windows server 2008R2 SP1</b>	x86-based system (IA32, Intel Xeon, and 32-bit or 64-bit AMD Opteron) IA64 Standard (Server Core) Edition, Enterprise (Server Core) Edition, Web Edition	
<b>Windows server 2012</b>	Windows Server 2012 - Standard Windows Server 2012 - Essentials Windows Server 2012 - Foundation Windows Server 2012 - Datacenter	
<b>Linux</b>	Support Client, Agent x86 (32-bit and 64-bit) Linux Red Hat 5.8 Linux Red Hat 6.3 SUSE Linux Enterprise Server 10.4 SUSE Linux Enterprise Server 11.2	Only support graphic management: Linux Red Hat 5 Client Linux Red Hat 6 Client SUSE Linux Enterprise Server 10 Client SUSE Linux Enterprise Server 11 Client
<b>Solaris(FC only)</b>	SPARC-based system x86-based system (Intel Xeon, and 32-bit or 64-bit AMD Opteron) ALUA is supported only in Solaris 11. Solaris 9 (SPARC only) Solaris 10, Solaris 11	
<b>VMware</b>	4.1 u3 5.0 u2 5.1	Conduct out-of-band management only through another supported operating system



## 9.5 Disk space requirement

Operating system	Spare Space	Other Requirements
Windows XP	255MB	(Min. memory is 512MB)
Windows Server 2003	291MB	
Windows Vista	291MB	
Windows Server 2008	291MB	
Linux	390MB	
Solaris	540MB	

## 9.6 Software installation steps

1. Insert SANMAN management software CD into DVD-ROM.
2. Open installation folder.
3. Start installation program,  
Windows – Double click executable files, i.e. AS-SAN-Manager\_11.10\_en\_Windows\_32bit.exe.  
UNIX——Key in a proper command in command prompt to start installation program, i.e. sh  
AS-SAN-Manager\_11.10\_linux\_64bit.bin.
4. Installation wizard appears, install according to wizard.

## 9.7 STRMGR management software module introduction

**Client** – This software contains graphic user interface used to manage storage array, as well as optional monitoring program, used to send an alarm message when a serious problem occurs in storage array.

**Practical program** – This software contains various practical programs, which could be used to enable operating system to recognize volumes created on storage array and view specific operating system device name of each volume.

**Agent** – This software enables management workstation to communicate via data IO path of the host and controller in storage array.

**Fault switch driver** – This software contains multipath driver, used to manage IO data path of controller in storage array. If any problem occurs in path or any controller fails, this driver will redirect IO requests from the host automatically, and send them to another controller in storage array.

**Java access bridge (JAB)** – It contains bridge software, making customer application based on windows technology could access mutually, and operate interactively.

## 9.8 Software module selection reference

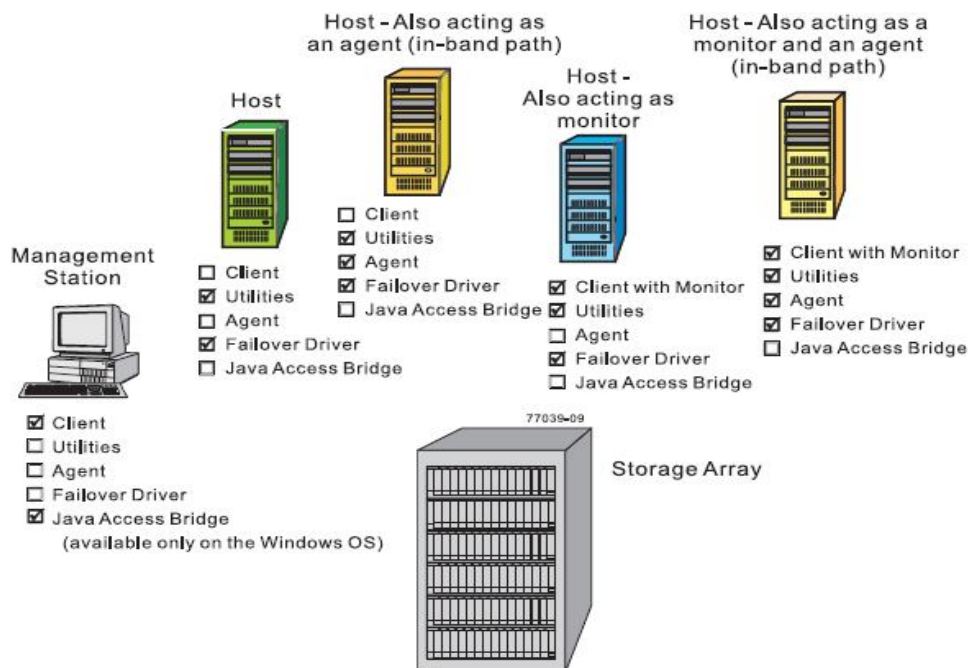

Figure 9-1

## 9.9 Install RDAC under Linux

1. Make sure that HBA card driver has been correctly loaded before installing RDAC, and HBA card shall be a driver of non-fault switch, it is suggested to use the same HBA card in one host, and confirm that HBA cards connected to disk array are within compatible list of AS1100H.

2. Enter STRMGR installation directory, key in the following commands under prompts, then press Enter, to unzip source file. In the following command, <rdac-package-name> is the name of RDAC software package.

```
tar -zxvf <rdac-package-name>.tar.gz
```

3. Switch to directory linuxrdac unzipped from RDAC source file, key in the following commands, then press Enter.

```
cd linuxrdac
```

4. Key in the following command to clean repeated target files under the directory.

```
make clean
```

5. Key in the following command to compile module.

```
make
```

6. Key in the following command to install RDAC.

```
make install
```

7. After executing make install command, modify configuration file of boot-load program, please refer to information output by make install command.

8. Detailed steps and other information please refer to readme.txt under linuxrdac directory.

## Chapter X Configure HBA Cards

This chapter introduces methods and steps to configure HBA cards under several mainstream operating systems, so as to implement connection to the server.

### 10.1 Configure HBA Cards in Windows Server 2003

Steps to configure HBA cards on Windows Server 2003 platform are as follows:

1. Insert HBA cards into the server.
2. Install system patches required by HBA.
3. Install related drivers of HBA cards in Windows Server 2003.
4. Reboot the system.

### 10.2 Configure HBA Cards in Windows Server 2008

Steps to configure HBA cards on Windows Server 2008 platform are as follows:

1. Insert HBA cards into the server.
2. Install related drivers of HBA cards in Windows Server 2008.
3. Reboot the system.

### 10.3 Configure HBA cards in Linux

Steps to configure HBA cards on Linux platform are as follows:

1. Insert HBA cards into the server. The driver is integrated in the system for Redhat5.4 and above version.
2. Reboot the system.

## Chapter XI Start Management Software

### 11.1 Management software startup

1. Start client management software.

Under windows system: Select Start>>Program>> STRMGR Storage Manager Client

Under UNIX operating system: Key in SMclient after command prompt and then press Enter.

2. Software runs and prompts an enterprise management window, select storage system to manage and double click, an array management window displays.

### 11.2 Enterprise Management Window (EMW) and Array Management Window (AMW)

EMW and AMW are two basic windows used for centralized management on storage array. When STRMGR management software is running, enterprise management window (EMW) will display first, which is used for centralized management on storage system in the enterprise, double click disk array in EMW, management software will display AMW user interface.

User Interface	Description
Enterprise Management Window (EMW)	Main window appears when STRMGR management software is started for the first time. User could view all storage arrays in management field. Used to add and delete storage arrays, set alarm notification (email and SNMP) as well as execute other advanced configuration. Provides statuses of all storage arrays. User could configure storage arrays via starting AMW management.
Array Management Window	Provides functions required to configure and maintain individual storage array, as well as fault detection. User could start AMW from EMW to carry out management on individual storage array. Multiple AMWs (each storage array occupies a window) could be displayed synchronously.
Setup Column (EMW and AMW)	Setup column provides quick entries for certain options, which are different according to different windows (EMW or AMW).

Setup page under EMW window, as shown in the following figure.

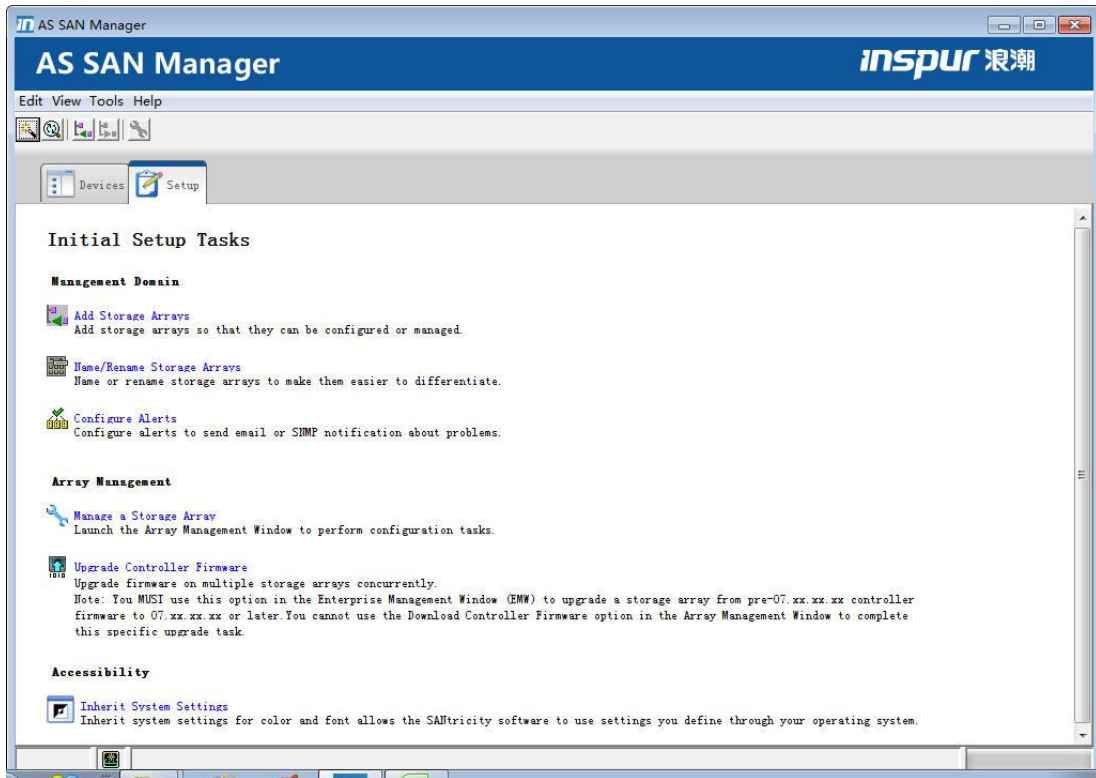

Figure 11-1

Setup page under AMW window, as shown in the following figure.

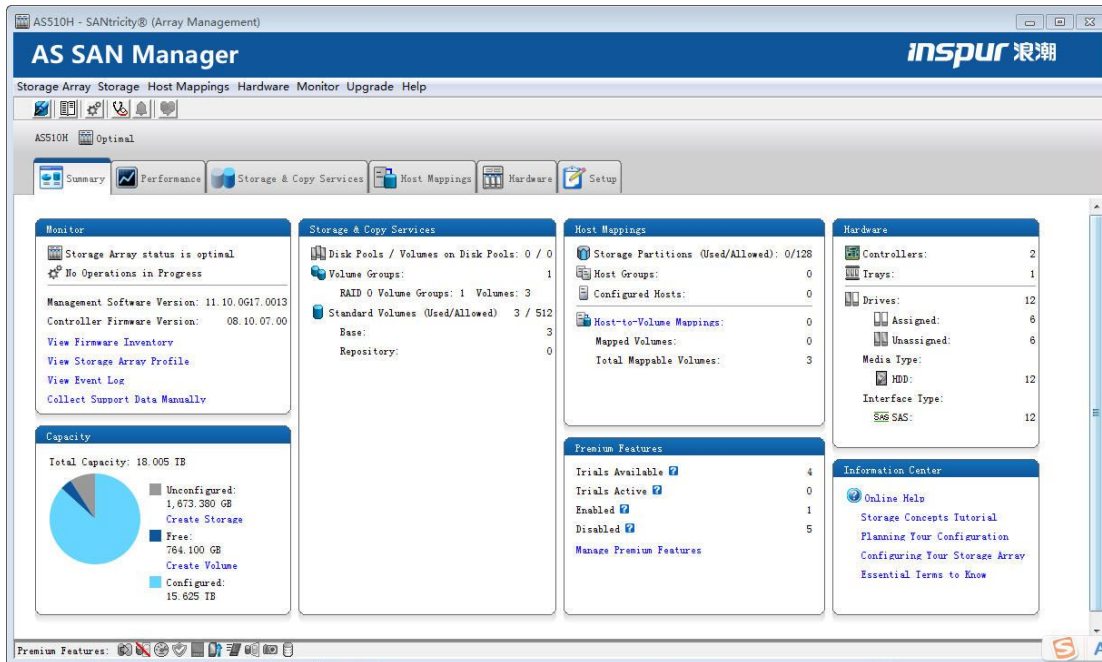

Figure 11-2

## Chapter XII Add a Storage Array

1. Select Tools>>Automatic Discovery from enterprise management window.
2. Click Ok to start auto search, this operation will search all storage arrays in local LAN, which may need several minutes or longer time. If no storage array is found, the reason may be network setting of storage array does not belong to local LAN, in this case, it is required to add a storage array manually.
3. If no storage array is found via auto search, select Add New Storage Array-Manual in enterprise management window, to add a storage array manually, the interface is as shown in the following figure,

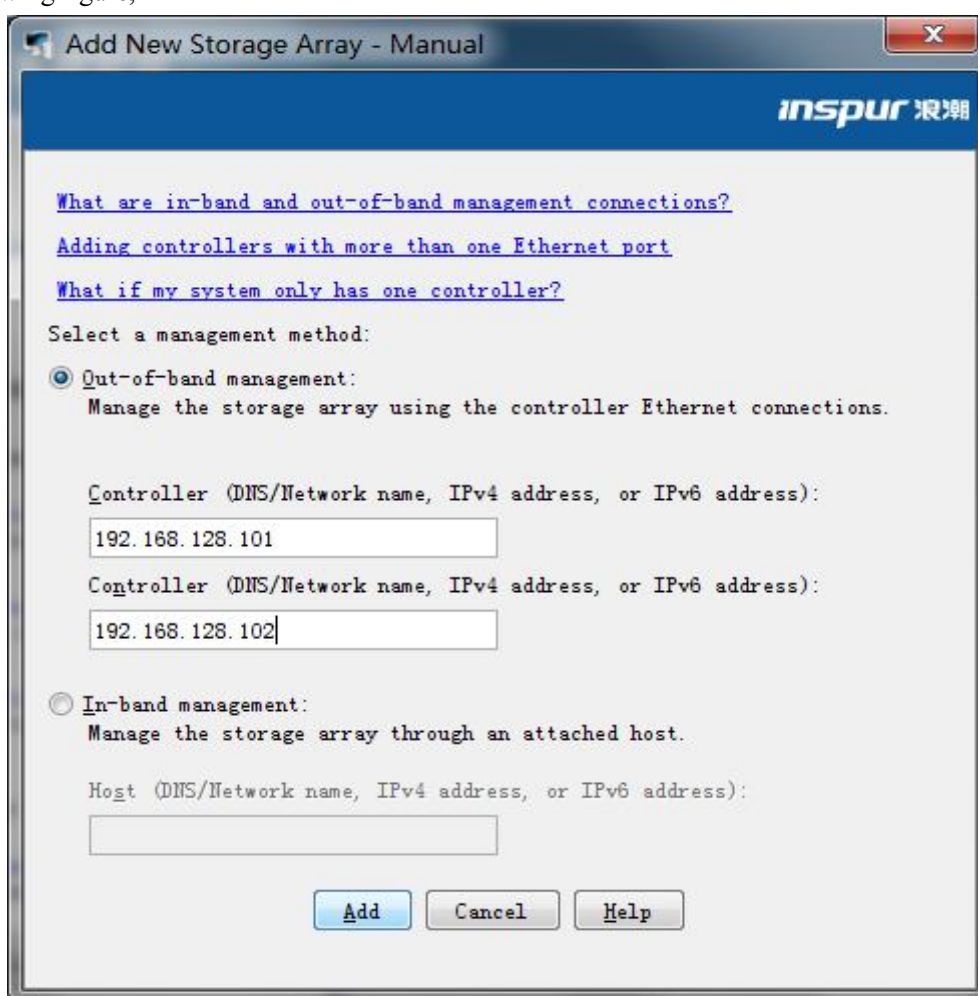

Figure 12-1

4. Select a corresponding management, if it is an out-of-band management, input IP addresses of two controllers (in IPv4 network, default management addresses of controller A and B are 192.168.128.101 and 192.168.128.102), if it is an in-band management, input hostname or ip address of the agent host, click add, the added storage array will display in EMW window.

## Chapter XIII Name the Storage Array

### 13.1 Naming notes

1. Disk array name in storage array software could be composed of letters, digits and special characters “\_”, “-“ or “#”, except these, no other special characters are allowed.

2. When naming a storage array, prefix “Storage Array” will be added before the name automatically.

3. When a storage array is first detected automatically or added manually, the default name of this storage array is “unnamed”.

### 13.2 Naming steps

1. Select an unnamed storage array and click locate, confirm its physical location via positioning indicator;

2. Select Setup interface in enterprise management window, click name/rename storage arrays.

3. Repeat the above steps for each unnamed storage array.

## Chapter XIV Troubleshooting

If there's any yellow indicator noticed during system power-on and checking, there will be a corresponding indication in enterprise management window (EMW) which stores management software.

1. In enterprise management window which stores management software, user could see running status of arrays: Optimal indicates normal running, without any problem, needs attention indicates a problem, which needs attention.
2. Select a storage array with needs attention status, click Ok, to start corresponding array management window (AMW).
3. Click Recover Guru, and solve existing problems according to hints.
4. Click re-check in Recover Guru, and verify whether problems have been solved.



## Chapter XV Configure Controllers Manually

This chapter introduces how to use STRMGR storage management software to configure and change IP addresses of controllers under the condition that there's no DHCP server.

### 15.1 Configuration notes

1. Please refer to content in Chapter V Select Management to decide whether to change controller configuration.
2. Use Ethernet port 1 on each controller for storage management, and reserve Ethernet port 2.
3. Ethernet port 1 and Ethernet port 2 shall be in different subnets.
4. Gateway configuration could only be carried out on one Ethernet port on each controller.

### 15.2 Configuration steps

1. Use in-band management or private network (laptop connects to storage controller via switch or direct connection) to initialize and find storage arrays (default management addresses of controller A and B in IPv4 network are 192.168.128.101 and 192.168.128.102).
2. Open enterprise management window (EMW), double click storage arrays to be configured in Device column, an array management window (AMW) displays.
3. Click Hardware column.
4. Select controller A in array management window (AMW) to highlight, and select controller>>configure>>Management ports , as shown in the following figure,

Ethernet port: Controller A, Port 1

Controller A DNS/Network name: target

Port 1 MAC address: 00:80:e5:1f:a5:84

Speed and duplex mode: Auto-negotiate

Enable IPv4

Enable IPv6

IPv4 Settings | IPv6 Settings

IPv4 Configuration:

Obtain configuration automatically from DHCP server

Specify configuration:

IP address:

0 . 0 . 0 . 0

Subnet mask:

0 . 0 . 0 . 0

Figure 15-1

5. Select controller A, port 1 in dropdown list of Ethernet port, and select auto-negotiate in dropdown list of speed and duplex mode (make sure that the switch in use is also set to auto-negotiate).
6. Select IPv4 or IPv6 according to network type, and set proper network parameters.
7. Select controller B and repeat step 4-6 to set network parameters for controller B.

## Chapter XVI Set a Password

This chapter introduces how to set a password in STRMGR storage management software, as well as other notices.

### 16.1 Password setting notes

1. In order to enhance protection function, please set a long password containing at least 15 letters, digits and characters. Max. password length could reach 30 characters.
2. Password is case sensitive.
3. Only at first attempt to change configuration (i.e. create a volume) or first execute a destructive operation (i.e. delete a volume), a password is required to be entered.
4. No password is required to view operation.
5. To cancel password protection, input the current password, then press enter directly in new password and confirm password textboxes directly without inputting passwords.

### 16.2 Password setting steps

1. Select Setup column in enterprise management window (EMW), click manage a storage array.
2. Select the storage array to set a password, click OK, an array management window (AMW) appears.
3. In setup column in AMW window, click set a storage array password.
4. Input password, and click OK to finish.

## Chapter XVII Configure Email and SNMP Alarm

This chapter introduces how to configure email and SNMP alarm under EMW window in STRMGR storage management software, so as to achieve the goal of remote controlling disk array running status.

### 17.1 Configuration notes

1. The purpose of setting alarm is to send an email or inform management personnel via SNMP, when there's any severe problem in storage arrays.

2. It is required to run event monitor (integrated in management software) on one management workstation to receive alarm messages. This machine shall be an uninterruptedly running computer, event monitor service shall have been installed and started, and event monitor service is called SMmonitor.

### 17.2 Alert notification configuration steps

1. Select Setup column in enterprise management window (EMW), click configure alerts.

2. Select a disk array to configure alerts, click ok.

If select all storage arrays, an alerts dialogue will appear.

If select individual storage array, first select a specific storage array, an alerts dialogue will appear after clicking ok.

3. Select the needed alert information type, and click ok to complete.

### 17.3 Mail server tab

To set email alerts, it is required to set mail server and mail sender address.

Sender contact information is optional information, if required, fill in corresponding information, otherwise, delete this field.

### 17.4 Email tab

Input email address, i.e. xxxx@company.com according to standard format.

Users can select the additional information to send in the information to send list, such as event+profile or event +support (including profile), which can help to know the current condition of storage array and is convenient for fault analysis.

## 17.5 SNMP tab

To set alert notification using SNMP trap, it is required to copy and compile management information library (MIB) files on specific network management workstation. Destination of SNMP trap is IP address or hostname running SNMP server host.

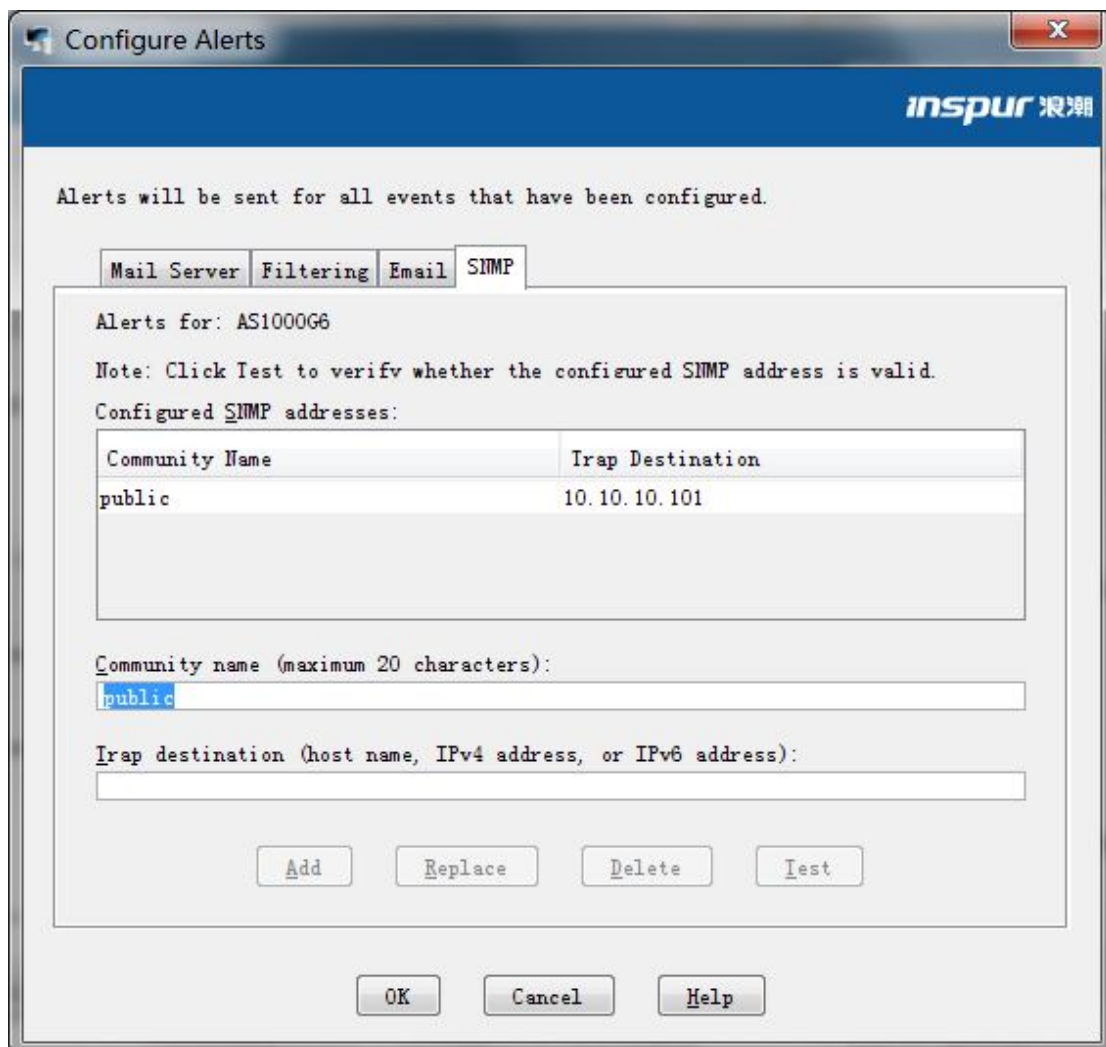

Figure 17-1 SNMP setting

## Chapter XVIII Cache Setting

### 18.1 Cache setting notes

1. During read operation, if the data requested by the host is in the cache, storage will not access hard disk, but send cache data to the host.
2. During write operation, data will be written to cache, and data will then be written to hard disk when cache data reaches a certain percentage.
3. When a controller fails, cache data in this controller will lose.
4. In order to protect data in cache, user could diminish the percentage triggering writing cache to hard disk, but during frequent read-write, this will reduce performance.
5. When cache mirroring function is enabled, if a controller fails, another controller will take over, while this controller will use mirrored cache to continue read-write operation.

### 18.2 Modify cache setting

1. On Setup page in EMW enterprise management window click Manage a Storage Array, a Select Storage Array dialogue appears.
2. Select a storage array to manage, click OK, a corresponding AMW array management window appears.
3. Select Storage Array>>Change>>Cache Settings, a Change Cache Settings dialogue appears.
4. Input a numerical value to trigger cache flush, and a numerical value to cease cache flush.
5. Select the size of cache block, and click OK.

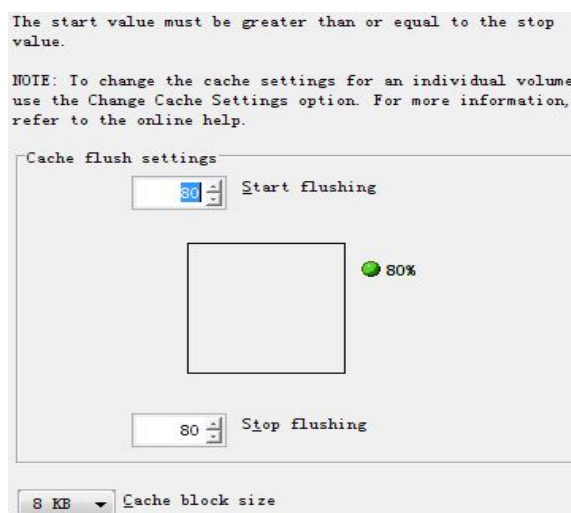

Figure 18-1

## 18.3 Modify volume cache setting

1. On Setup page in EMW enterprise management window click Manage a Storage Array, the Select Storage Array dialogue appears.

2. Select a storage array to manage, click OK, a corresponding AMW array management window appears.

3. Select Storage>>Volume>>Change>>Cache Settings, a Change Cache Settings dialogue appears.

4. To enable read operation to use cache, select Enable read caching.

5. To enable write operation to use cache, select Enable write caching.

6. If selecting Enable write caching, the following 2 selection boxes will appear:

Enable write caching without batteries – When controller battery discharge finishes or incomplete battery charge or there's no battery, data write caching is enabled.

Enable write caching with mirroring – Memories of two redundant controllers are mirrored to each other.

7. Select Dynamic cache read prefetch to enable copying other data during data copy.

8. Click OK.

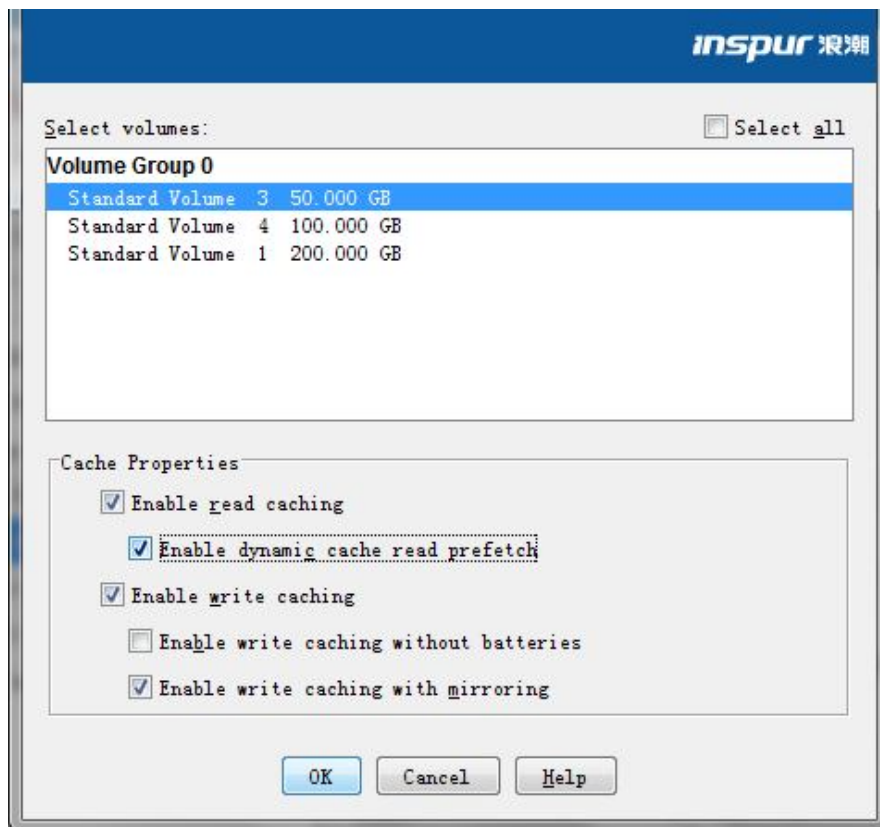

Figure 18-2

## Chapter XIX Add a Host

This chapter introduces usage requirements on storage partitions of STRMGR storage management software, as well as how to define host group and the host.

### 19.1 Key terminology

#### **Host**

A host is connected to a storage array directly or indirectly, accessing volumes on storage array via HBA cards or host ports of network cards.

#### **Host bus adapter (HBA)**

A board card inserted into the host, providing direct data transmission between the host and storage array controller via receive and send ports, and each HBA card could contain one or more ports.

#### **Ports of HBA cards**

Physical connecting points on HBAs in the host, used to connect fiber-optic cables. Connection may be two types: Direct connection, host and storage array connection; switch structure, host and switch connection.

### 19.2 Adding host notes

Host directly or indirectly connected to a storage array is recognized by storage management software via WWN number of HBA cards on it. But management software does not know detailed HBA locations on hosts, so it is required to understand and record relationship between each host and its HBAs before defining a host.

### 19.3 Define a host group

A host group is a set composed of two or more hosts, which share access on specific volumes on storage arrays in storage partitions, while host group is a logical entity created in storage management software, and is only required to be created while using storage partition function.

### 19.4 Storage partition usage notes

Storage partition is a logical entity composed of one or more volumes, which could be accessed by a single host or shared among multiple hosts composing a certain host group. A storage partition could be imagined as a virtual storage array, while storage partition is to separate physical storage arrays into multiple virtual storage arrays, and limit access on certain hosts via storage partitions.



Under the following circumstances, it is no need to create a storage partition:  
Only one host accesses volumes on storage arrays, refer to Figure 19-1.

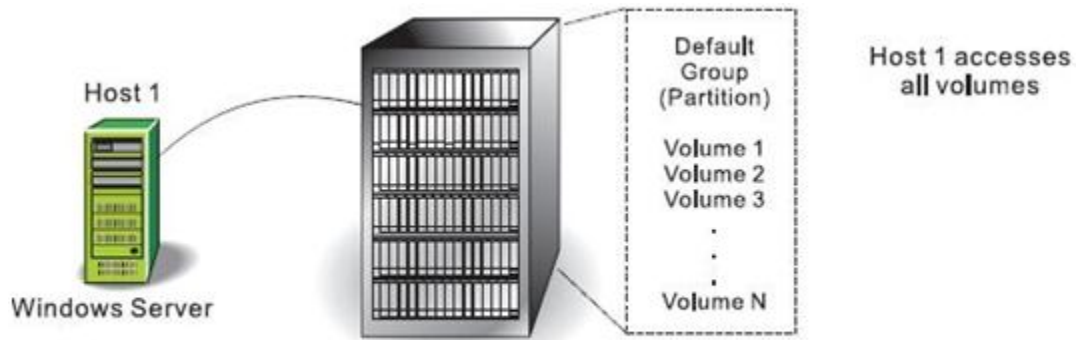

Figure 19-1

All directly or indirectly connected hosts share access on all volumes on storage arrays, note: These hosts must have the same operating system, and there's shared and access control software managing volumes on these hosts. Refer to Figure 19-2.

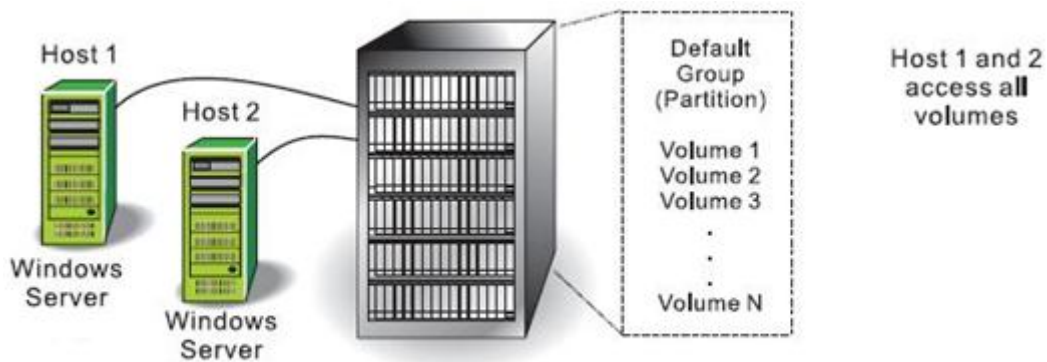

Figure 19-2

Under the following circumstances, it is required to create a storage partition:  
In the hope that some hosts only access certain volumes on storage arrays, refer to Figure 19-3.

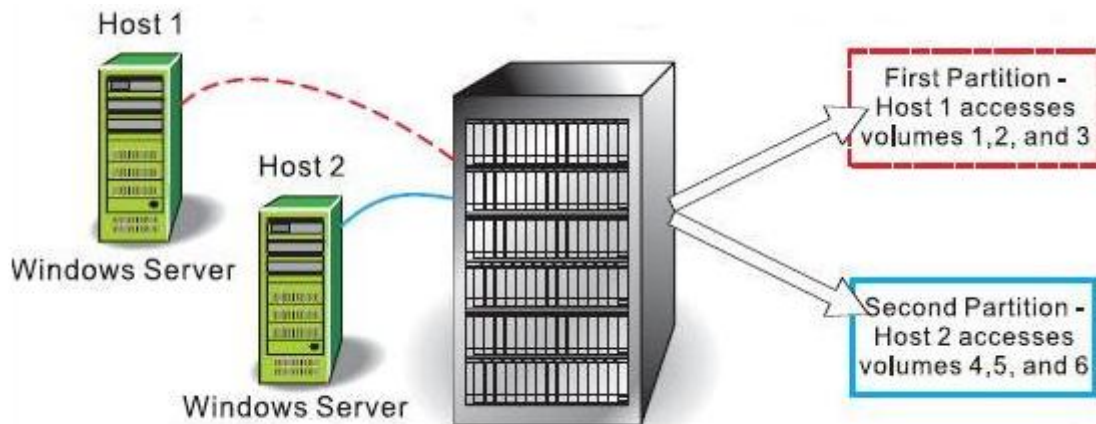

Figure 19-3

Hosts connecting storage arrays have different operating systems, so it is required to create storage partitions for each operating system, refer to Figure 19-4.

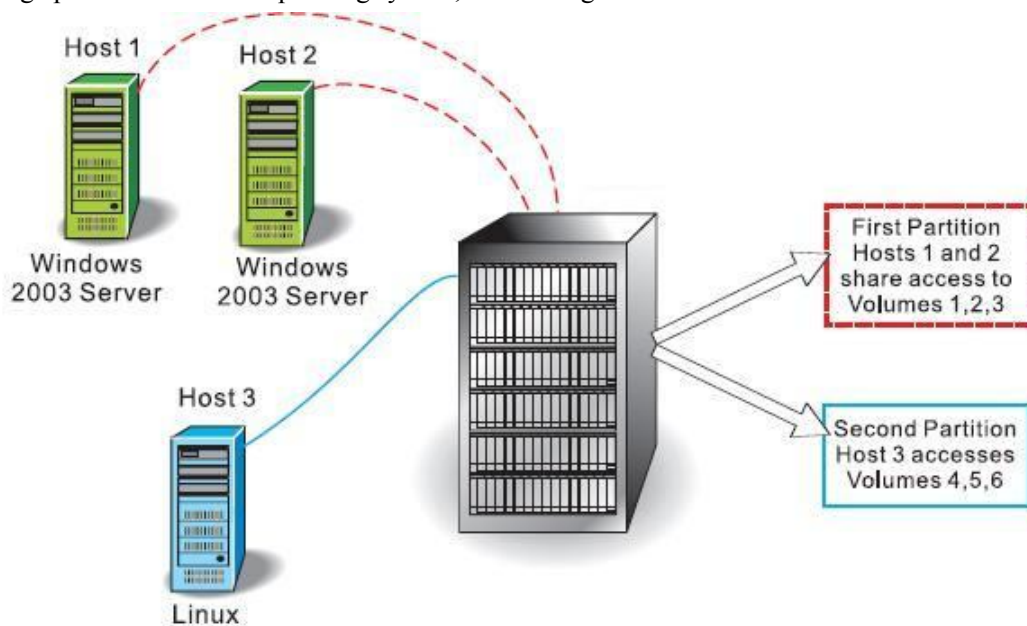

Figure 19-4

## 19.5 Adding a host steps

1. Select setup page in enterprise management window (EMW), click manage a storage array.
2. In the interface displayed, select a storage array to configure, click ok, an array management window AMW appears.
3. In AMW window, select setup page, click manually define hosts.
4. Refer to interface instructions and online help, define a host and correlate to HBA host ports, and define a host group if necessary.

## Chapter XX Configure Storage System

This chapter introduces how to use STRMGR storage management software to carry out configuration on storage system, introduces concepts and steps on creating RAID volume group, LUN and mapping.

### 20.1 Key terminology

#### **Unconfigured capacity**

Capacity on unallocated disk driver in storage arrays to be used for system configuration, and unconfigured capacity could be used to configure unallocated disk driver into a volume group.

#### **Spare capacity**

Remaining capacity on existing volume group, and spare capacity on volume group could be used to create another volume.

#### **Default group**

If storage space is not divided into storage partitions, all volumes will be mapped to default group of the storage.

#### **FDE disk**

Full disk encryption is a kind of encryption hard disk, and all data written into this hard disk will be encrypted.

### 20.2 Capacity allocating notes

1. Unconfigured capacity or spare capacity of exiting volume group could be used to create a volume.

If using unconfigured capacity to create a volume, it is required to create a new volume group first (a group of disk drivers using raid).

If using spare capacity to create a volume, it is only required to appoint parameters of this volume, for volume group has already existed.

2. While configuring volume capacity on storage arrays, please be sure to reserve some unallocated disk drivers, these drivers may be needed for the following reasons:

To create an extra volume group for new capacity;

To be used in hot spare disk protection;

To increase spare capacity in existing volume group to meet capacity needs in future;

To be used in extra storage space required by certain advanced functions (i.e. snapshot volume).

3. If storage arrays contain more than one disk driver (i.e. SAS disk and SSD disk), each disk driver type will have a correlated unconfigured capacity. Drivers of different types could not be mixed in the same volume group.

## 20.3 Volume group and volume creating notes

1. Each volume group could create one or more volumes, in order to handle different data requirements or for maximum capacity limit on single volume, each volume group could create more than one volume.

2. Supported RAID levels are 0, 1, 3, 5, 6 and 10.

Raid 0 does not provide data redundancy;

Raid10 is not an independent raid level, which is only supported while creating a raid1 volume group composed of four or more drivers.

Raid1 could only be configured when there's an even number of disks in volume group.

Raid3 or raid5 could only be configured when there're 3 or more disks in volume group.

Raid6 could only be configured when there're 5 or more disks in volume group.

## 20.4 Host to volume mapping and storage partition notes

1. A logical address is required while creating each volume mapping, which is called logical unit number (LUN), and the host uses this address to access data on volume.

2. When creating a volume manually, there're two mappings for selection;

Default mapping – If no storage partition is to be used, please select this option. Software will specify an LUN for this volume, and hosts in system default partitions will share these volumes.

Post-map – If a storage partition is to be used, please select this option. Please provide the following information according to wizard:

Specify host groups and hosts;

Specify expected host groups or volumes to be accessed by hosts;

Allocate LUN number for each accessing volume;

## 20.5 Hot spare disk usage notes

1. Hot spare disk is redundancy of another level added by storage arrays, and it is suggested to create at least one hot spare disk for each storage volume group.

2. Hot spare disk does not provide protection for RAID 0 volume group, for data on this volume group has no redundancy.

3. Hot spare disk is not used for specific volume group, but for the globe, which means it will be used in any fault driver in storage arrays, and fault drivers shall have the same driver type and capacity with hot spare disk (equal to or less than).

## 20.6 Storage configuration steps

1. Click Manage a Storage Array on the setup page of Enterprise Management Window (EMW), and the window of select storage arrays displays.

2. Select the storage arrays to configure, click ok, system will start related Array Management Window (AMW).

3. On setup page of Array Management Window (AMW), click Configure Storage Array.

4. Select configuration task:

Auto configuration— this method can create volume groups constituted by volumes with same capacity, and appoint proper hot spare disk protection automatically. This method is suitable for the condition that having no special capacity requirements on each volume or hoping to configure volume group, volume or hot spare disk; users can select the appropriate configuration from the suggested configuration list.

Create volume group and volume—this method can create just one volume at a time, but give more control to volume group and volume (i.e. raid level, volume group and volume capacity). If having special capacity requirements on each volume or hoping to have more control when specifying various parameters, please use this method.

Assign hot spare disk—this method can allow management software to assign appropriate hot spare disk automatically (same as the aforementioned auto configuration method), or select the unconfigured driver to create hot spare disk manually.

5. Select the suitable step according to the conditions.

Don't use storage partition function and select auto configuration method, please go to step 6.

Don't use storage partition function and select auto configuration method, confirm whether all volumes have been mapped to the default group, please go to step 8.

Use storage partition function, please go to step 7.

6. Click map volume button on the setup page of AMW, select the default group, and assign LUN for each group, please go to step 8.

7. Click mappings, select suitable host or host group, volume or LUN, select mappings—define, click sanshare storage partitioning, and then operate according to prompts.

8. After creating all volumes and mapping, register these volumes on the host to enable them to be used by the operating system.

According to different operating systems, use different tools to enable volumes (assign drive letter, create mount points and so on), refer to host operating system documentation for more details.

If HP-UX is used, the following command shall be run on each host, to modify overtime value on each block device created on storage arrays to 120: `pvchange -t 120 /dev/dsk/cxtidx` (*which shall be run again if the host is restarted*).

**Hazardous Substances or Elements Name and Content Table –  
Storage System**

Part Name	Hazardous Substances or Elements					
	Pb	Hg	Cd	Cr(VI)	PBB	PBDE
Case	×	○	○	○	○	○
Mainboard	×	○	○	○	○	○
Memory	○	○	○	○	○	○
Hard Disk	○	○	○	○	○	○
Power Supply	×	○	○	○	○	○
System Fan	×	○	○	○	○	○
Cable	○	○	○	○	○	○
Data Cable	×	○	○	○	○	○
Optical Fiber Line	×	○	○	○	○	○
Switch Module	×	○	○	○	○	○
Controller	×	○	○	○	○	○
Central Processor	×	○	○	○	○	○
Rail	○	○	○	○	○	○
Printing	○	○	○	○	○	○
CD	○	○	○	○	○	○
Package	○	○	○	○	○	○
Packing Plastic Bags	○	○	○	○	○	○
Packing Pads	○	○	○	○	○	○

**Instructions:**

1. ○: Indicates content of hazardous substances in all homogenous materials of this part is below limit regulated in Requirements for Concentration Limits for Certain Hazardous Substances in Electronic Information Products.
2. ×: Indicates content of hazardous substances in at least one homogenous material of this part is below limit regulated in Requirements for Concentration Limits for Certain Hazardous Substances in Electronic Information Products. In the table, “×” indicates printed board welding technique limit fails to reach limit requirements.
3. All the above parts are possible configuration parts in product, for actual product configuration please refer to configuration label.