

Terminus Plug-In Products User Manual



JANUS REMOTE
COMMUNICATIONS

Bulletin	JA03-UM
Revision	P16
Date	23 April 2013

TABLE OF CONTENTS

TABLE OF CONTENTS and DISCLAIMER.....	2-3
1 APPLICABILITY TABLE.....	4
2 REFERENCES	4
2.1 Telit Document List	
2.2 Janus Document List	
3 OVERVIEW.....	5
3.1 Introduction.....	5
3.2 Preview	5
4 GSM865CF OVERVIEW.....	6
4.1 GSM Features	6
4.2 GSM Block Diagram	6
5 CDMA864CF OVERVIEW	7
5.1 CDMA Features.....	7
5.2 CDMA Block Diagram.....	7
6 UMTS864CF OVERVIEW.....	8
6.1 UMTS Features	8
6.2 UMTS Block Diagram	8
7 HSPA910CF OVERVIEW	9
7.1 HSPA+ Features.....	9
7.2 HSPA+ Block Diagram.....	9
8 EVDO910CF OVERVIEW	10
8.1 EV-DO Features	10
8.2 EV-DO Block Diagram	10
9 INTERFACES.....	11-23
9.1 Serial Interface	11-12
9.2 Power Supply.....	12
9.3 Audio Interface.....	13
9.4 Plug-In Pin-Out.....	14
9.5 VRTC Details.....	15
9.6 GPIO Details.....	15-18
9.7 Internal Interfaces.....	19
9.8 LED Status Indicators.....	20
9.9 RF Interface.....	21-22
9.10 SIM Card Interface	23
9.11 Header Interface Mounting Options.....	23
9.12 Screw Mounting.....	23

TABLE OF CONTENTS continued

10 GSM865CF TECHNICAL SPECIFICATIONS	24-31
10.1 Electrical Specifications.....	24-26
10.2 GSM Mechanical Specifications.....	27
10.3 MS20 GPS Specifications.....	28
10.4 GSM865CF Getting Started.....	29-31
11 CDMA864CF TECHNICAL SPECIFICATIONS	32-40
11.1 Electrical Specifications.....	32-35
11.2 CDMA Mechanical Specifications.....	36
11.3 Setting Up a Terminal Emulator for use with the CDMA864CF Terminus.....	37-40
12 UMTS864CF TECHNICAL SPECIFICATIONS	41-49
12.1 Electrical Specifications.....	41-44
12.2 UMTS Mechanical Specifications.....	45
12.3 Setting Up a Terminal Emulator for use with the UMTS864CF Terminus.....	46-49
13 HSPA910CF TECHNICAL SPECIFICATIONS	50-58
13.1 Electrical Specifications.....	50-53
13.2 HSPA+ Mechanical Specifications.....	54
13.3 Setting Up a Terminal Emulator for use with the HSPA910CF Terminus.....	55-58
14 EVDO910CF TECHNICAL SPECIFICATIONS	59-65
14.1 Electrical Specifications.....	59-61
14.2 EV-DO Mechanical Specifications.....	62
14.3 Setting Up a Terminal Emulator for use with the EVDO910CF Terminus.....	63-65
15 DESIGN CONSIDERATIONS	66
15.1 GSM, CDMA, UMTS, HSPA+ and EV-DO Minimum Required Module Pin Connects.....	66
15.2 Debug.....	66
APPENDICES	67-68
Approvals.....	67
Safety.....	67
Antenna Care and Replacement.....	67
Abbreviations.....	67
Ordering Information.....	68
Revision History.....	68

DISCLAIMER

The information contained in this document is the proprietary information of Connor-Winfield Corporation and its affiliates (Janus Remote Communication). The contents are confidential and any disclosure to persons other than the officers, employees, agents or subcontractors of the owner or licensee of this document, without the prior written consent of Connor-Winfield, is strictly prohibited. Connor-Winfield makes every effort to ensure the quality of the information it makes available. Notwithstanding the foregoing, Connor-Winfield does not make any warranty as to the information contained herein, and does not accept any liability for any injury, loss or damage of any kind incurred by use of or reliance upon the information. Connor-Winfield disclaims any and all responsibility for the application of the devices characterized in this document, and notes that the application of the device must comply with the safety standards of the applicable country, and where applicable, with the relevant wiring rules. Connor-Winfield reserves the right to make modifications, additions and deletions to this document due to typographical errors, inaccurate information, or improvements to programs and/or equipment at any time and without notice. Such changes will, nevertheless be incorporated into new editions of this application note.

All rights reserved 2012 Connor-Winfield Corporation

1 APPLICABILITY TABLE

Product	Part Number
GSM865CF (with GPS)	v1.1
GSM865CF (without GPS)	v2.0
CDMA864CF (Sprint Certified)	v2.0
CDMA864CF (Verizon Certified)	v3.0
UMTS864CF	v1.0
HSPA910CF	v1.0
EVDO910CF	v3.0

2 REFERENCES

2.1 Telit Document List

GSM865CF V1.1 (AT&T Certified)

Our terminal uses Telit module GE865, Firmware version 10.00.003

Please refer to Telit's website at www.telit.com for the latest information on the GSM GE865 module.

[Telit_GE865_Hardware_User_Guide](#)

[Telit_Modules_Software_User_Guide](#)

[Telit_AT_Commands_Reference_Guide - Issue #9](#)

Please go to www.janus-rc.com to download the AT Command Reference Guide

CDMA864CF V2.00 (Sprint Certified)

Our terminal uses Telit module CC864-DUAL, firmware version 09.01.003 or 09.01.004

Please refer to Telit's website at www.telit.com for the latest information on the CDMA CC864-DUAL module.

[Telit_CC864-DUAL_Hardware_User_Guide](#)

[Telit_CC864-DUAL_Software_User_Guide](#)

[Telit_CC864-DUAL_AT_Commands_Reference_Guide - Issue #2](#)

Available at www.janus-rc.com

CDMA864CF V3.00 (Verizon Certified)

Our terminal uses Telit module CC864-DUAL, firmware version 09.01.023-B021

Please refer to Telit's website at www.telit.com for the latest information on the CDMA CC864-DUAL module.

[Telit_CC864-DUAL_Hardware_User_Guide](#)

[Telit_CC864-DUAL_Software_User_Guide](#)

[Telit_CC864-DUAL_AT_Commands_Reference_Guide - Issue #4](#)

Available at www.janus-rc.com

UMTS864CF

Our terminal uses Telit module UC864-G, firmware version 08.01.127 or 08.01.147

Please refer to Telit's website at www.telit.com for the latest information on the UMTS UC864-G module.

[Telit_UC864_Hardware_User_Guide](#)

[Telit_UC864_Software_User_Guide](#)

[Telit_UC864_AT_Commands_Reference_Guide - Issue #7](#)

Available at www.janus-rc.com

HSPA910CF

Our terminal uses Telit module HE910.

Please refer to Telit's website at www.telit.com for the latest information on the HSPA+ HE910 Module.

[Telit_HE910_Hardware_User_Guide](#)

[Telit_HE910_Software_User_Guide](#)

[Telit_HE910_AT_Commands_Reference_Guide](#)

[Telit_HE910_DVI_App_Note](#)

EVDO910CF

Our terminal uses Telit module DE910.

Please refer to Telit's website at www.telit.com for the latest information on the EV-DO DE910 Module.

[Telit_DE910_Hardware_User_Guide](#)

[Telit_DE910_Software_User_Guide](#)

[Telit_DE910_AT_Commands_Reference_Guide](#)

[Telit_HE910_DVI_App_Note](#)

2.2 Janus Document List

Please refer to the NavSync's website, www.navsync.com, for the latest information on the MS20.

MS20 Documentation

3 OVERVIEW

3.1 Introduction

The User Manual for the Plug-In Terminus devices is intended to illustrate how users can integrate and implement the features of each communication version of the device. The common factors are explained in detail, as well as special considerations and diagrams for each module. The module differences are highlighted in this manual for design considerations for future model placement.

3.2 Preview

The Terminus GSM865CF, CDMA864CF, UMTS864CF, HSPA910CF and EVDO910CF are self-contained, multi-band, globally capable, M2M communication devices designed to provide a comprehensive solution to application problems for our M2M customers. They utilize the proven technology of Telit's GE865, UC864-G, CC864-DUAL, HE910 and DE910 modules, respectively, for their core communications engines. NavSync's MS20 module adds the flexibility of GPS to the GSM865CF only.

3.2.1 Functional Description

Plug-In Module Differences

GPS Functionality

- CDMA864CF has an internal GPS solution available via Telit AT command interface
- UMTS864CF has an internal GPS solution available via Telit AT command interface
- GSM865CF has an optional stand alone NavSync MS20 12 channel GPS receiver that is not accessible via Telit AT command port.
- HSPA910CF has an internal GPS solution available via Telit AT command interface
- EVDO910CF has an internal GPS solution available via Telit AT command interface

Physical Dimensions

- Length and width of devices are equal
- Heights of different devices will vary

Cellular

- GSM/GPRS
- EV-DO/CDMA/1xRTT (Sprint and Verizon certified versions)
- HSPA/UMTS/EDGE/GPRS/GSM

AT commands may vary between different cellular technologies.

USB

- EVDO, CDMA, & UMTS (FS USB Device Interface)
- HSPA+ (HS USB Device Interface)
- GSM (not available)

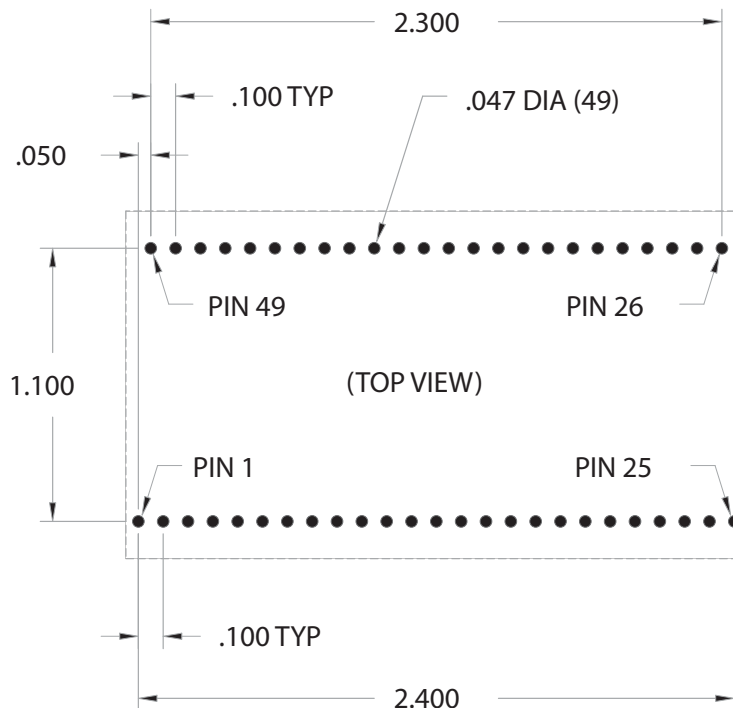

4 GSM OVERVIEW

4.1 GSM Features

- Quad-band EGSM 850 / 900 / 1800 / 1900 MHz
- GSM/GPRS protocol stack 3GPP Release 4 compliant
- Control via AT commands according to 3GPP 27.005, 27.007 and Telit custom
- Control via remote AT commands
- Serial port multiplexer 3GPP 27.010
- SIM application toolkit 3GPP TS 51.014
- SIM access profile
- TCP/IP stack access via AT commands
- Over-the-Air firmware management
- Voice and SMS (MO / MT)
- Output power
 - Class 4 (2W) @ 850 / 900 MHz
 - Class 1 (1W) @ 1800 / 1900 MHz
- Sensitivity:
 - -107 dBm (typ.) @ 850 / 900 MHz
 - -106 dBm (typ.) @ 1800 / 1900 MHz
- DARP/SAIC support
- Dimensions: 2.5 x 1.4 x 0.365"
- Operational temperature range (without GPS): -40°C to 80°C
- Operational temperature range (GPS configured): -30°C to 65°C
- Internal LDO regulator
 - Input voltage range: 4.75 to 5.25Vdc (5.0Vdc nominal)
 - Supply disable via terminal input pin
- SIM Card
 - Standard locking SIM card socket
 - Or, optional SIM on a chip
- GSM and GPS available via Murata GSC miniature RF connector
- GPS
 - Stand alone GPS available at terminal pin interface
 - Dedicated GPS antenna connection with active antenna support

4.2 GSM Block Diagram

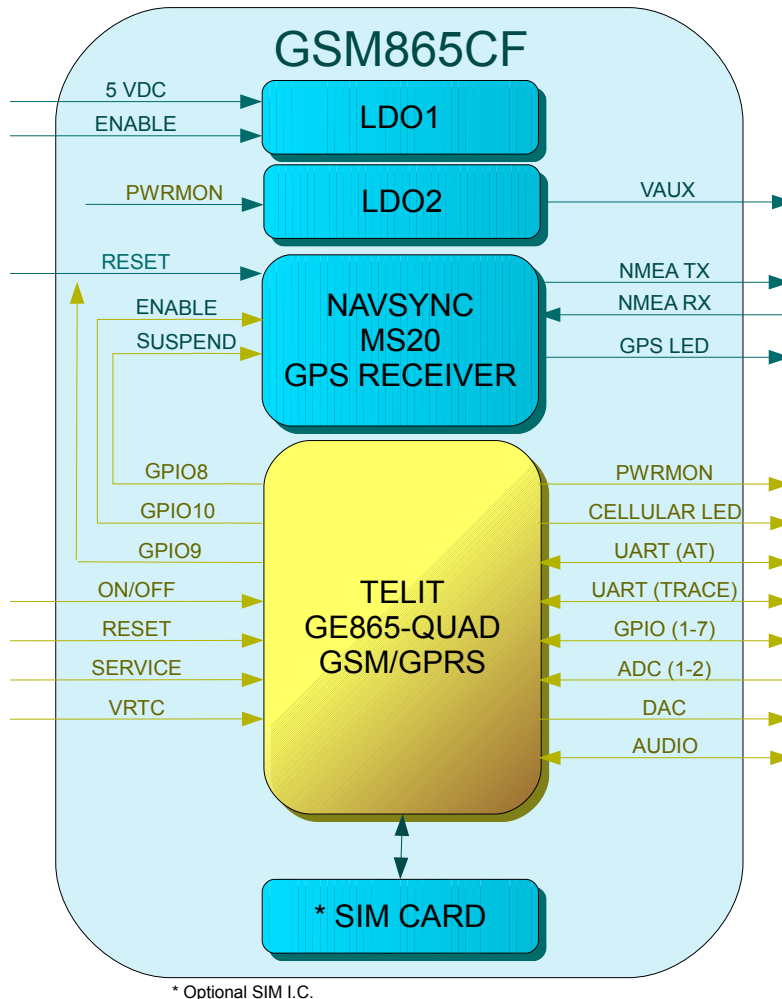

Figure 1 GSM Block Diagram

5 CDMA OVERVIEW

5.1 CDMA Features

- Dual-band CDMA 800 / 1900 MHz
 - Air interface IS-95A/B and CDMA 2000
 - 1xRTT data up to 153.6Kbps (full duplex)
 - TCP/IP stack access via AT commands
 - Over-the-Air firmware management
 - Voice and SMS (MO / MT)
 - Full voice support includes supplementary services
 - Output power
 - 24.3 dBm (270mW)
 - Sensitivity:
 - -108 dBm (typ.) @ 800 MHz
 - -108 dBm (typ.) @ 1900 MHz
 - Operational temperature range: -30°C to 80°C
 - Dimensions: 2.5 x 1.4 x 0.415"
- Internal LDO regulator
 - Input Voltage range: 4.75 to 5.25Vdc (5.0Vdc Nominal)
 - Supply disable via terminal input pin
 - GSM and GPS available via Murata GSC miniature RF connector
 - GPS
 - Stand alone GPS available at AT command interface
 - GpsOne® (user and control plane)
 - NMEA data
 - GPS fix on demand
 - Dedicated GPS antenna connection with active antenna support

5.2 CDMA Block Diagram

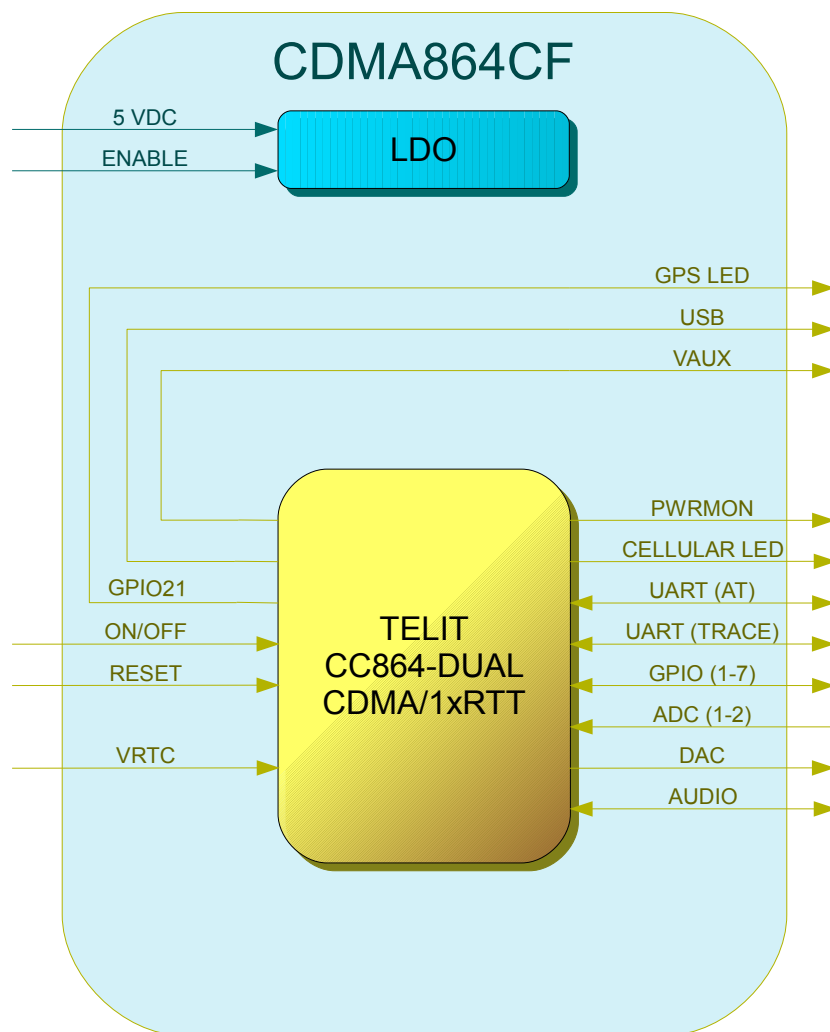

Figure 2 CDMA Block Diagram

6 UMTS OVERVIEW

6.1 UMTS Features

- HSDPA 7.2 Mbps
- Tri-band UMTS / HSDPA / (WCDMA / FDD) 850/1900/2100 MHz
- Quad-band EGSM 850 / 900 / 1800 / 1900 MHz
- GPRS/EDGE CLASS 12
- TCP/IP stack access via AT commands
- Over-the-Air firmware management
- Voice and SMS (MO / MT)
- Output power
 - Class 4 (2W, 33 dBm) @ GSM 850 / 900
 - Class 1 (1W, 30 dBm) @ GSM 1800 / 1900
 - Class 3 (0.25W, 24 dBm) @ UMTS
 - Class E2 (0.5W, 27 dBm) @ EDGE 850 / 900
 - Class E2 (0.4W, 26 dBm) @ EDGE 1800 / 1900
- Dimensions: 2.5 x 1.4 x 0.420"
- Operational temperature range: -30°C to 80°C
- Internal LDO regulator
 - Input voltage range: 4.75 to 5.25Vdc (5.0Vdc Nominal)
 - Supply disable via terminal input pin
- SIM Card
 - Standard locking SIM card socket
 - Or, optional SIM on a chip
- GSM and GPS available via Murata GSC miniature RF connector
- GPS
 - Stand alone GPS available at AT command interface
 - NMEA data
 - Dedicated GPS antenna connection with active antenna support

6.2 UMTS Block Diagram

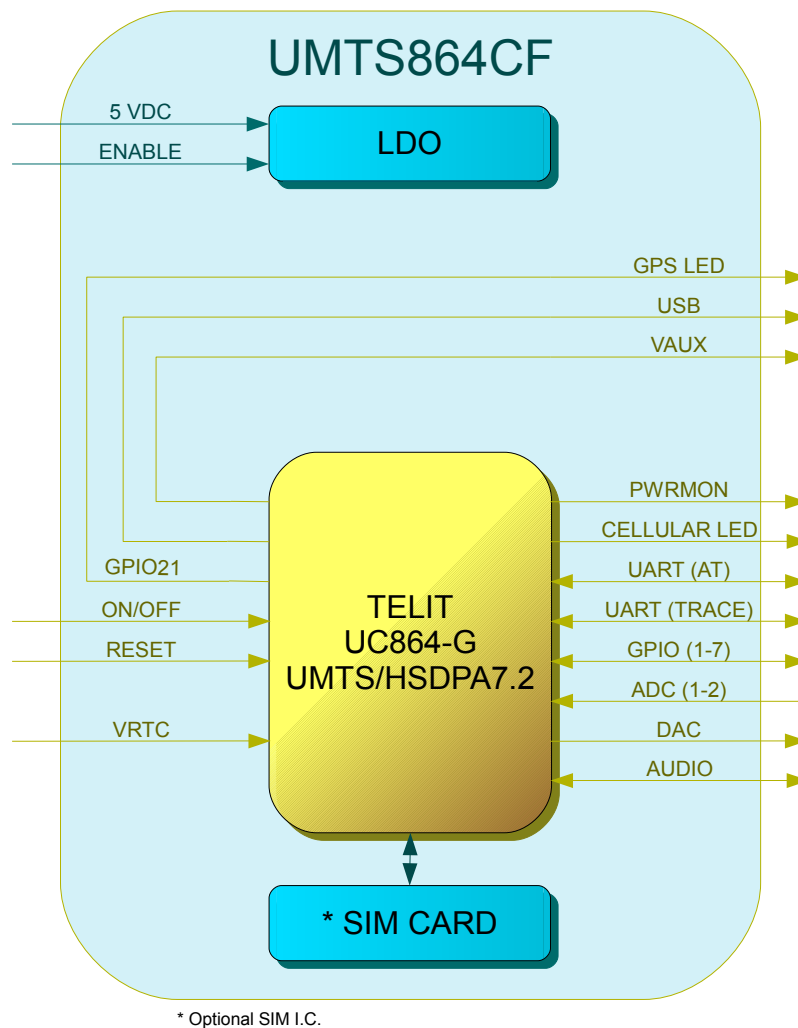

Figure 3 UMTS Block Diagram

7 HSPA+ OVERVIEW

7.1 HSPA+ Features

- Penta-Band HSPA+
 - GSM Quad Band 850, 900, 1800, 1900 MHz
 - UMTS/HSPA+ Penta Band 850, 900, 1700, 1900, 2100 MHz
- EGPRS / WCDMA / HSDPA / HSUPA Protocol Stack 3GPP Release 7
- Control via AT commands according to 3GPP TS27.005, 27.007 and Telit customized AT commands
- Serial port multiplexer 3GPP T27.010
- SIM application Tool Kits 3GPP TS 51.014
- SIM access profile
- UDP / TCP / FTP / SMTP Stack
- Voice and SMS
- Output power
 - Class 4 (2W, 33 dBm) @ GSM 850 / 900
 - Class 1 (1W, 30 dBm) @ GSM 1800 / 1900
 - Class 3 (0.25W, 24 dBm) @ UMTS
 - Class E2 (0.5W, 27 dBm) @ EDGE 850 / 900
 - Class E2 (0.4W, 26 dBm) @ EDGE 1800 / 1900
- Sensitivity
 - -109.5 dBm @ 850/1900 MHz
 - -109 dBm @ 900 Mhz
 - -110 dBm @1800 Mhz
 - -111 dBm @ WCDMA B1/B4/B5
 - -110 dBm @ WCDMA B2/B8
- Coding scheme 1 to 4 (GPRS) & Modulation Coding scheme 1 to 9 (EDGE)
- EDGE Class 33, MS Class B
- Data
 - HSPA: DL: Up to 21.0Mbps, UL: Up to 5.76Mbps
 - WCDMA: DL: Up to 384kbps, UL: Up to 384kbps
 - EDGE: DL: Up to 296kbps, UL: Up to 236.8kbps
 - GPRS: DL: Up to 107kbps, UL: Up to 85.6kbps
 - Asynchronous non transparent CSD up to 9.6 kbps
- DARP I
- Dimensions: TBD
- Operational Temperature Range: -30°C to 85°C
- Internal Switching Regulator:
 - Input Voltage Range: 3.0 to 5.25Vdc (5Vdc nominal)
 - Supply disable via terminal input pin
- SIM Card
 - Standard locking SIM card socket
 - Optional SIM chip
- GSM, GSM RX Diversity, and GPS available via Murata GSC miniature RF connector

7.2 HSPA+ Block Diagram

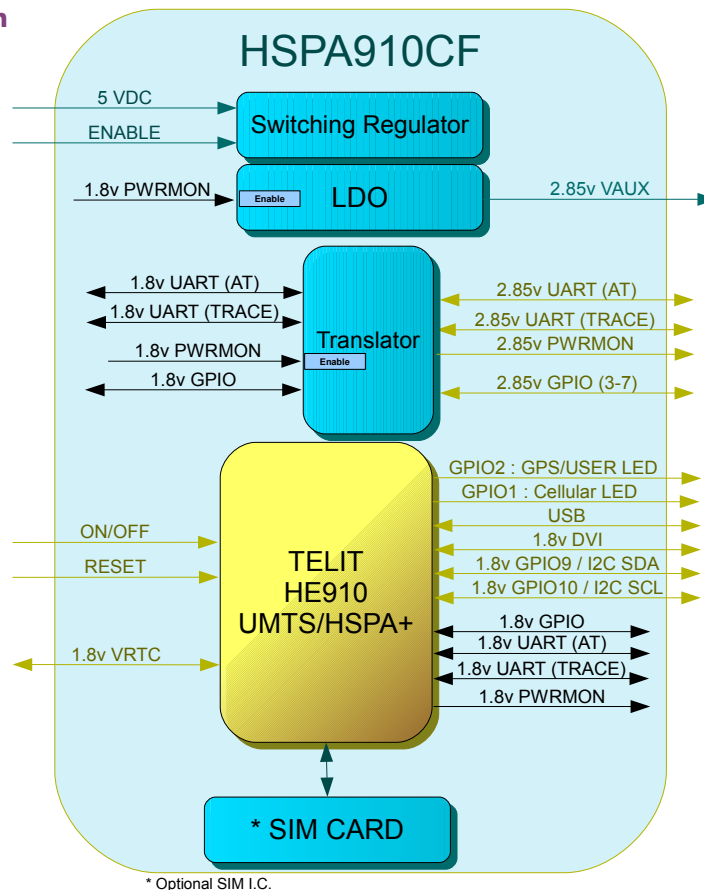

Figure 4 HSPA910CF Block Diagram

8 EV-DO OVERVIEW

8.1 EV-DO Features

- Dual Band EV-DO Rev. A 800/1900 MHz
- Control via AT commands according to 3GPP TS27.005, 27.007 and Telit customized AT commands
- Serial port multiplexer 3GPP T27.010
- UDP / TCP / FTP / SMTP Stack
- SMS access
- Full voice via PCM
- OTA provisioning, device management, and firmware upgrades
- Standalone GPS, gpsOne, and Glonass
 - Sensitivity: $\leq -161\text{dBm}$
- Output power
 - $\leq 24.4\text{dBm}$ @ CDMA1x
 - $\leq 24\text{dBm}$ @ EV-DO 1x
- Sensitivity
 - $\leq -108\text{dBm}$ @ CDMA 1x
 - $\leq -109\text{dBm}$ @ EV-DO 1x
- Data
 - DL: Up to 3.1Mbps, UL: Up to 1.8Mbps
- Operational Temperature Range: -30°C to 85°C
- Internal Switching Regulator:
 - Input Voltage Range: 4.75 to 5.25Vdc (5V nominal)
 - Supply disable via terminal pin
- Cell, Cell RX Diversity, and GPS available via Murata GSC miniature RF connector

8.2 EV-DO Block Diagram

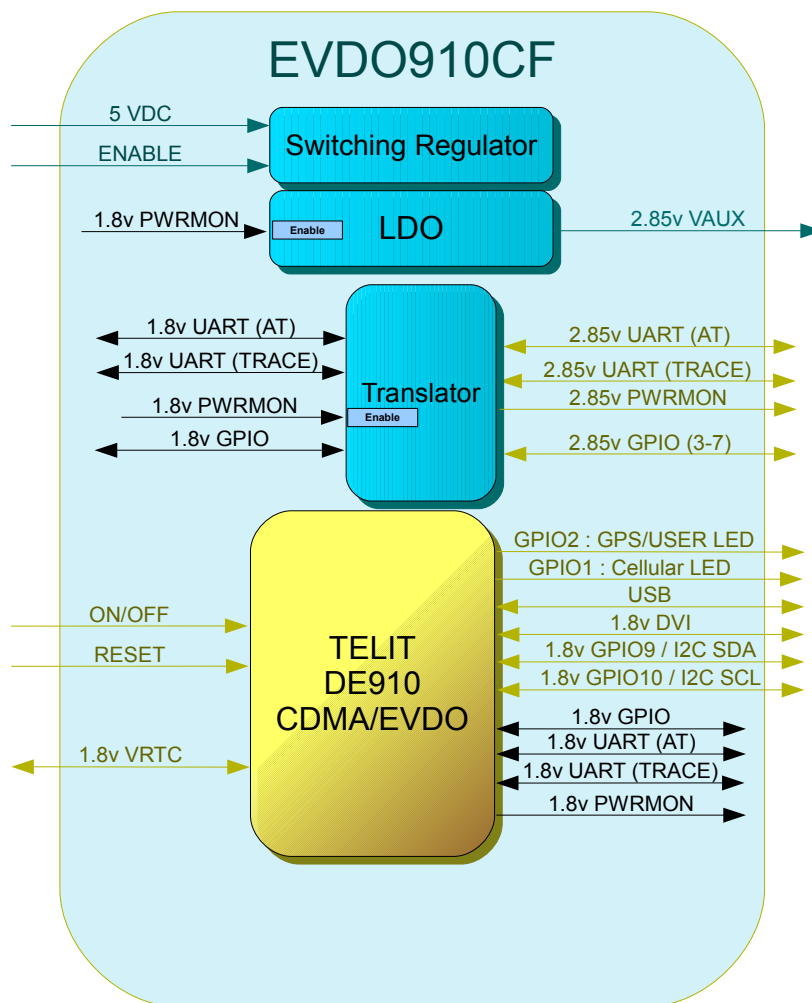

Figure 5 EVDO910CF Block Diagram

9 INTERFACES

9.1 Serial Interface

9.1.1 UART Serial Port

The serial interface is a CMOS level UART. Default Communications settings for this port are as follows:

- Baud Rate: 115.2 kbps
- Bits: 8
- Stop Bits: 1
- Parity: None
- Hardware Handshaking: Yes

When not using the baud rate default, the GSM865CF supports autobaud while the CDMA864CF, UMTS864CF, HSPA910CF and EVDO910CF do not. Please refer to the individual modem's Getting Started section for details.

Note: If you are not using Hardware Handshaking, please note that RTS must be connected to GROUND for proper communications where flow control is unused.

9.1.1.1 UART Level Translation

The electrical limits for the UART are listed in the individual modem sections. Please be aware of these limits, as operating outside of them may damage the unit. If the limits must be exceeded, level translation can be used.

An example of basic translation for RXD/TXD only is found below.

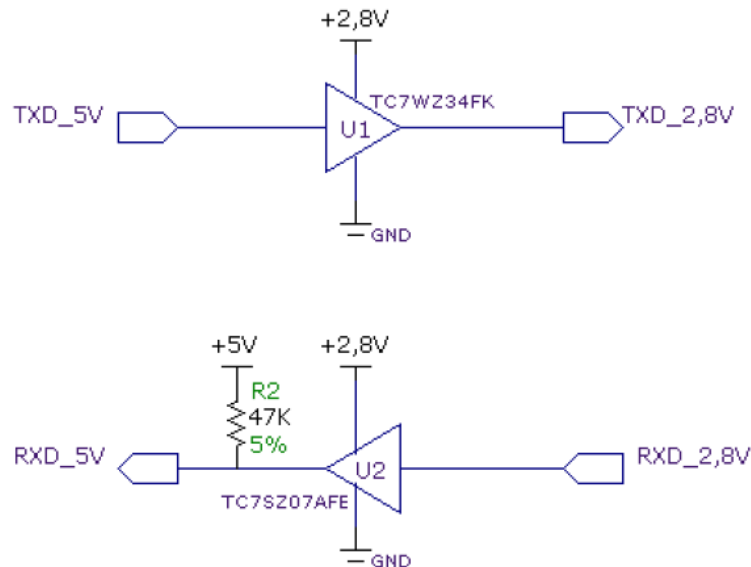

Figure 6 UART Level Translation Example

Although an external source for the level translation can be used, VAUX can be used as the reference instead. However, since the CDMA864CF and UMTS864CF require AT commands to control VAUX, PWRMON may be used as an enable to the external reference. Do not use PWRMON directly as the reference.

9.1.2 USB Port

UMTS864CF, CDMA864CF, HSPA910CF & EVDO910CF include an integrated universal serial bus (USB) transceiver, compliant with USB 2.0 specifications. The UMTS/CDMA864CF are USB full speed devices (12Mb/s), while the HSPA910CF and EVDO910CF are a high speed device (480Mb/s). High data rates for the USB enabled modems are only available over the USB interface. In order for proper power-up of the UMTS864CF, CDMA864CF, HSPA910CF and the EVDO910CF, the USB_VBUS line MUST be disconnected until the unit is otherwise fully powered and on. If the USB_VBUS line is attached and powered before the main power is brought up and the module turned on, power sequencing issues may occur.

Note: You must implement the USB interface in order to locally update radio firmware for CDMA and UMTS applications. The GSM865CF does not have USB port available.

9 Interfaces continued

9.1.2 USB Port continued

9.1.2.1 USB Connection Diagram

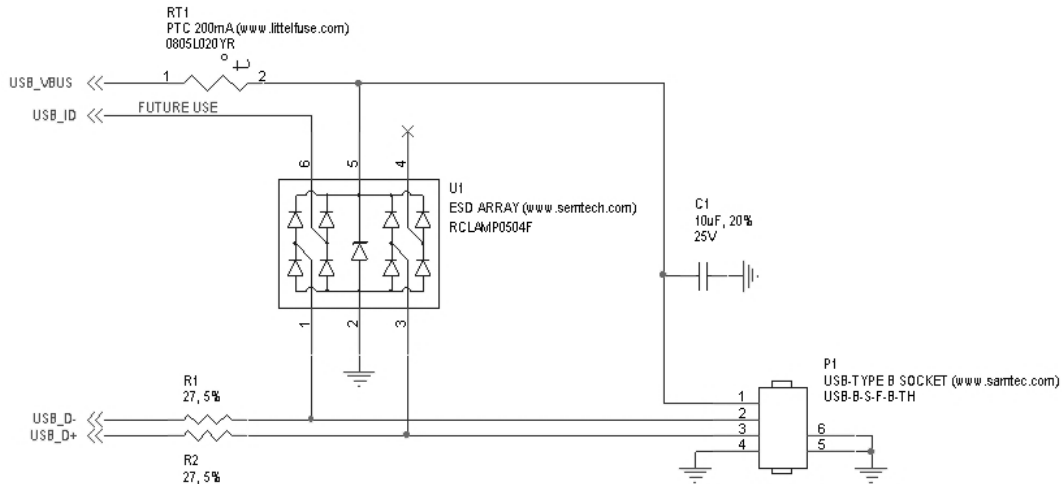

Figure 7 USB Connection Diagram

9.2 Power Supply

The module's power supply accepts input voltages from 4.75Vdc to 5.25Vdc and requires a nominal current sourcing capacity of 5W (maximum 10W).

Power Supply

A good understanding of the load transients is required in order to meet the power requirements of a cellular radio. Power supply design, thermal management and layout are outside the scope of this document. Please refer to power supply manufacturers for product documentation and design application notes.

Cellular Load Transients

Cellular radios use a mix of modulation schemes including, but not limited to, TDMA and CDMA. In GSM/GPRS systems the transmission and reception of data is achieved via Time Division Multiple Access (TDMA). TDMA transmission is made up of RF bursts that cause 2A current pulses at the supply input of the cellular radio. These current pulses occur at a frequency of 216 Hz and can persist for 1.2 to 2.4ms.

Plug-In Module Regulator (GSM865CF, CDMA864CF, & UMTS864CF)

These Terminus Plug-In modules are designed with a linear dropout (LDO) regulator to power the cellular radio. The LDO requires an input voltage of 4.75 to 5.25Vdc to maintain regulation and specified junction temperature limits. 4Vdc is supplied to the supply inputs of the cellular radio. The LDO has an efficiency of > 80%, and can source enough current to guarantee proper operation of the cellular radio.

Note: The LDO input is capable of withstanding 16Vdc. This is outside the recommended operating voltage of the plug-in modules but is helpful to know when designing input transient circuitry.

Plug-In Module Regulator (HSPA910CF, EVDO910CF, CDMA910CF)

This Terminus Plug-In module is designed with a switching regulator to power the cellular radio. The regulator can receive an input voltage of 3.7 to 5.25VDC to maintain regulation, but can also accept down to 3.3VDC, in which regulation is bypassed. This is useful for battery operated applications. Note that input voltage below 4.75VDC are outside of rated specifications and thus not supported..

Note: The regulator input is capable of withstanding 6VDC Maximum. This is outside the recommended operating voltage of the Plug-In modules but but is helpful to know when designing input transient circuitry.

Plug-In Module Input Supply Requirements

Please refer to the power supply specification for the specific plug-in module you are designing into your circuit. The current values are given in average units due to the pulsed nature of the transmission scheme. It is recommended that your supply source the full peak current value of the transmission pulse in order to maintain proper cellular operation. The use of bulk output capacitors on your supply allows for a less powerful supply. If you are designing your PCB to accept all of the plug-in modules it is necessary to choose the highest consumption power supply requirement and design for it.

9 Interfaces continued

9.3 Audio Interface

9.3.1 GSM865CF, CDMA964CF and UMTS864CF

To ensure proper operation of the audio interface in the CDMA864CF, please make sure that AT#CAP=0 is issued if not already set. It is recommended for best noise rejection that both the input and output of the audio interface are implemented with differential connection.

Note: UMTS864CF module allows for data only.

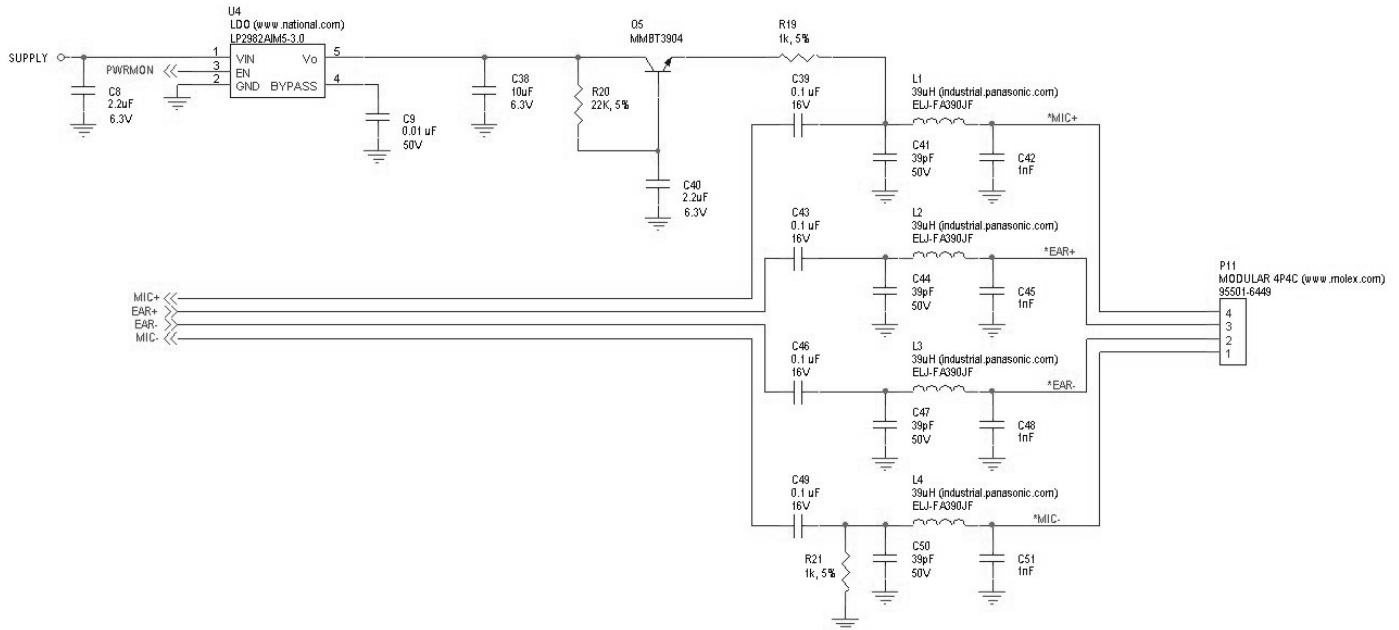

Figure 8 Analog Audio Circuit Diagram

9.3.2 HSPA910CF and EVDO910CF

The HSPA910CF and EVDO910CF modules use a DVI audio interface which will not work with the analog audio interface of the other Terminus Plug-In modems. The HSPA910CF supports both I2S and PCM while the EVDO910CF only supports PCM, both support master and slave modes, requiring a codec to convert the interface to the user's need. Below is a block diagram based on I2S and the MAX9867 codec with GPIO 9 and 10 being used for I2C control of the codec.

Please refer to the Telit HE910 and DE910 DVI Application Note for full information and example schematics utilizing the MAX9867 Audio codec.

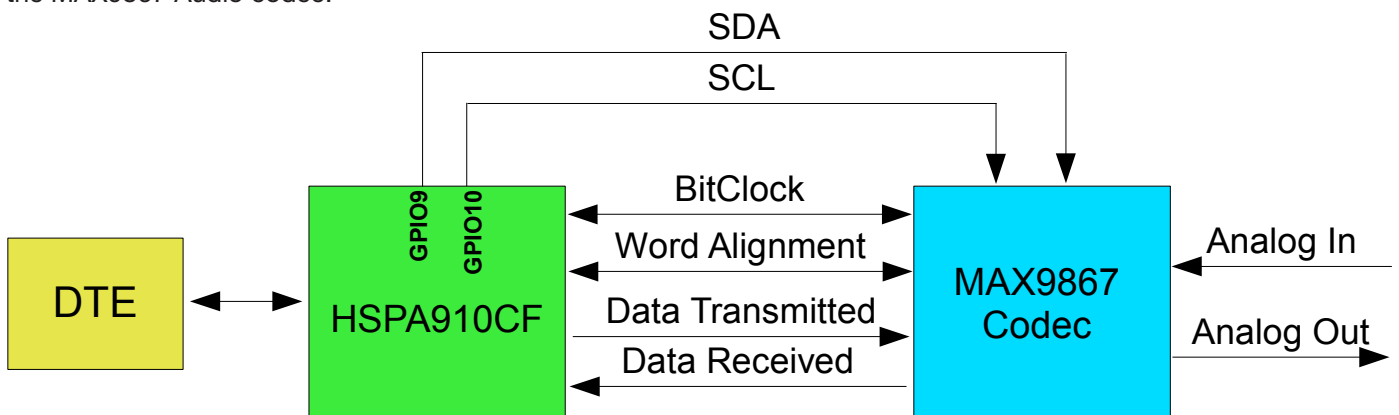

Figure 9 DVI Block Diagram

9 Interfaces continued

9.4 Plug-In Pin-Out

PIN		DESCRIPTION	STANDARD I/O SIGNAL	POWER- ON STATE	PULL TYPE	TERMINAL	NOTE
PIN	NAME						
1	SUPPLY	Positive Supply Input	Power	N/A	N/A	ALL	
2	SUPPLY	Positive Supply Input	Power	N/A	N/A	ALL	
3	ENABLE SUPPLY	Enable/Disable Supply	Input	N/A	PULL-UP to Vin: 681k	ALL	1
4	RXD	UART - Transmit Line	Output	N/A	N/A	ALL	6
5	DSR	UART - Data Set Ready	Output	N/A	N/A	ALL	6
6	CTS	UART - Clear to Send	Output	N/A	N/A	ALL	6
7	RING	UART - Ring Indicator	Output	N/A	N/A	ALL	6
8	DCD	UART - Data Carrier Detect	Output	N/A	N/A	ALL	6
9	TXD	UART - Receive Line	Input	N/A	N/A	ALL	6
10	DTR	UART - Data Terminal Ready	Input	N/A	N/A	ALL	6
11	RTS	UART - Request to Send	Input	N/A	N/A	ALL	5
12	GROUND	Supply Reference	Power	N/A	N/A	ALL	
13	TRACE_TX	Debug UART - Transmit Line	Output	N/A	N/A	ALL	6
14	TRACE_RX	Debug UART - Receive Line	Input	N/A	N/A	ALL	6
15	USER/GPS LED	USER LED/GPS Status	Output	N/A	N/A	ALL	6
16	CELLULAR LED	Cellular Status	Output	N/A	N/A	ALL	6
17	SERVICE	Enable Firmware Load	Input	N/A	N/A	GSM865CF	6
18	PWRMON	Power Monitor Output	Output	N/A	PULL-DOWN:1M	ALL	6
19	ON_OFF	Toggle Cellular Radio On Off State	Input	N/A	PULL-UP to VTRC: 47k	ALL	1
20	RESET	Reset Cellular Radio	Input	N/A	PULL-UP: 47k	ALL	1
21	MIC+ /DVI WAO	Positive Analog Audio Input/DVI Word Alignment	Analog Input/WCLK	N/A	N/A	MOST	8
22	MIC- /DVI RX	Negative Analog Audio Input/DVI Received Data	Analog Input/SDIN	N/A	N/A	MOST	8
23	EAR+ /DVI TX	Positive Analog Audio Output/DVI Transmitted Data	Analog Output/SDOUT	N/A	N/A	MOST	8
24	EAR- / DVI CLK	Negative Analog Audio Output/DVI Data Clock	Analog Output/BCLK	N/A	N/A	MOST	8
25	GROUND	Supply Reference	Power	N/A	N/A	ALL	
26	GROUND	Supply Reference	Power	N/A	N/A	ALL	
27	USB_D-	USB Differential Data (-)	CMOS Bi-Direction	N/A	N/A	MOST	9
28	USB_D+	USB Differential Data (+)	CMOS Bi-Direction	N/A	N/A	MOST	9
29	USB_VBUS	USB Supply	Power	N/A	N/A	MOST	9
30	USB_ID	Future Use	Analog Input	N/A	N/A	NONE	2,3
31	I2C_SDA	I2C Data	CMOS Bi-Direction	INPUT	N/A	HSPA910CF	
32	I2C_SCL	I2C Clock	CMOS Bi-Direction	INPUT	N/A	HSPA910CF	
33	GPS_RX	GPS NMEA UART - Receive Line	CMOS Input	N/A	N/A	GSM865CF	6
34	GPS_TX	GPS NMEA UART - Transmit Line	CMOS Output	N/A	N/A	GSM865CF	6
35	GPS_RESET	GPS Reset	Input	HIGH-Z	PULL-HIGH: 47k	GSM865CF	1
36	GPIO_7	General Purpose I/O	Bi-Direction	INPUT	N/A	ALL	6
37	GPIO_6	General Purpose I/O	Bi-Direction	INPUT	N/A	ALL	6
38	GPIO_5	General Purpose I/O	Bi-Direction	INPUT	N/A	ALL	6
39	GROUND	Supply Reference	Power	N/A	N/A	ALL	
40	GPIO_4	General Purpose I/O	Bi-Direction	INPUT	N/A	ALL	6
41	GPIO_3	General Purpose I/O	Bi-Direction	INPUT	N/A	ALL	6
42	GPIO_2	General Purpose I/O	Bi-Direction	INPUT	N/A	MOST	7
43	GPIO_1	General Purpose I/O	Bi-Direction	INPUT	N/A	MOST	7
44	DAC	Digital to Analog Converter	Analog Output	N/A	N/A	MOST	7
45	ADC2	Analog to Digital Converter	Analog Input	N/A	N/A	MOST	7
46	ADC1	Analog to Digital Converter	Analog Input	N/A	N/A	MOST	7
47	VRTC	Cellular Radio External RTC Supply	Power	N/A	N/A	ALL	
48	VAUX	Reference Voltage	Analog Output	N/A	N/A	ALL	
49	GROUND	Supply Reference	Power	N/A	N/A	ALL	

Notes:

1. It is required that this input be controlled by an Open Collector/Drain Output. Do not use an external pull-up resistor; a pull-up is included internal to the module.
2. Not currently implemented
3. USB On The Go: Analog input used to sense whether a peripheral device is connected and determine the peripheral type; a host or a peripheral.
4. DAC output must be integrated (for example, with a low pass filter) in order to obtain an analog voltage.
5. RTS must be connected to GROUND if flow control is not used.
6. Refer to individual modules for standard I/O levels.
7. Excludes the HSPA910CF.
8. The HSPA910CF and EVDO910CF uses DVI signals; it does not have analog audio.
9. Excludes the GSM865CF.

9 Interfaces continued

9.5 VRTC Details

The VRTC pin brings out the real time clock supply, which is separate from the rest of the part. This allows only the RTC to be ON when all other parts of the device are OFF. A backup capacitor can be added to this pin to increase RTC autonomy while powering the device from a battery. The CDMA910CF cannot take advantage of the VRTC functionality.

No devices should be powered from this pin.

Equations:

$$C = 3600 * [(Btime * IRTC)/(VRTC - VRTCmin)]$$

$$Btime = [C * (VRTC - VRTCmin)/(IRTC * 3600)]$$

Where:

VRTC – The Starting voltage of the capacitor (Volt)

VRTCmin – The minimum voltage acceptable for the RTC circuit. (Volt)

IRTC (Ampere) – The current consumption of the RTC circuitry when VBATT = 0

Btime - Backup Time (Hours)

C = Capacitor value (Farads)

Values for the GSM865CF/CDMA864CF/UMTS864CF

VRTC = 2.05v Nominal

VRTC minimum input voltage to function = 1.1v

IRTC = 10uA nominal

Values for the HSPA910CF

VRTC = 1.8v Nominal

VRTC minimum input voltage to function = 1.1v

IRTC = 2uA nominal

Values for the EVDO910CF

VRTC = 3.1v Nominal

VRTC minimum input voltage to function = 2.0v

IRTC = 1.1uA nominal

Values for the CDMA910CF

VRTC = N/A

VRTC minimum input voltage to function = N/A

IRTC = N/A

For Example, using the HSPA910CF numbers:

Btime = 96 hours (4 days)

C = 1.0F

9.6 GPIO Details

Terminus GPIO are configurable as input, output, and special function. Configuration is controlled by the customer specific application via AT commands sent on the UART/USB interface. The following table describes GPIO configuration options.

Please note that these alternate functions are not supported by the HSPA910CF, EVDO910CF, and CDMA910CF.

GPIO	Configuration	Alternate Function	ON_OFF State
1	Input / Output		pull-up
2	Input / Output	Jamming detect output	pull-up
3	Input / Output		pull-down
4	Input / Output	RF transmission control	pull-down
5	Input / Output	RFTX monitor output	pull-down
6	Input / Output	Alarm output	pull-up
7	Input / Output	Buzzer output	pull-down

9 Interfaces continued

9.6 GPIO Details continued

9.6.1 Using a GPIO Pad as INPUT

The GPIO pads, when used as inputs, can be connected to a digital output of another device and report its status, provided this device has interface levels compatible with the Voltage levels of the GPIO of the module.

9.6.2 Using a GPIO Pad as OUTPUT

The GPIO pads, when used as outputs, can drive CMOS digital devices or compatible hardware. When set as outputs, the pads have a push-pull output.

9.6.3 Using the Alarm Output GPIO6

When configured as alarm output, the GPIO6 pad is controlled by the module, rising when the alarm starts and falling after the issue of a dedicated AT command. This output can be used to power up the module controlling micro-controller or application at the alarm time. This enables you to program a timely system wake-up to achieve periodic actions and completely turn off the application or module during sleep periods to reduce the sleep consumption. In battery-powered devices, this feature will greatly improve the autonomy of the device.

Note: During RESET the line is set to HIGH logic level

9.6.4 Using the Buzzer Output GPIO7

When the GPIO7 pad is configured as buzzer output, it is controlled by the module and will drive the buzzer driver with appropriate square waves. This allows your application to easily implement the buzzer features when needed, such as call incoming or SMS incoming.

A sample interface scheme is included below to demonstrate how to interface a buzzer to the GPIO7:

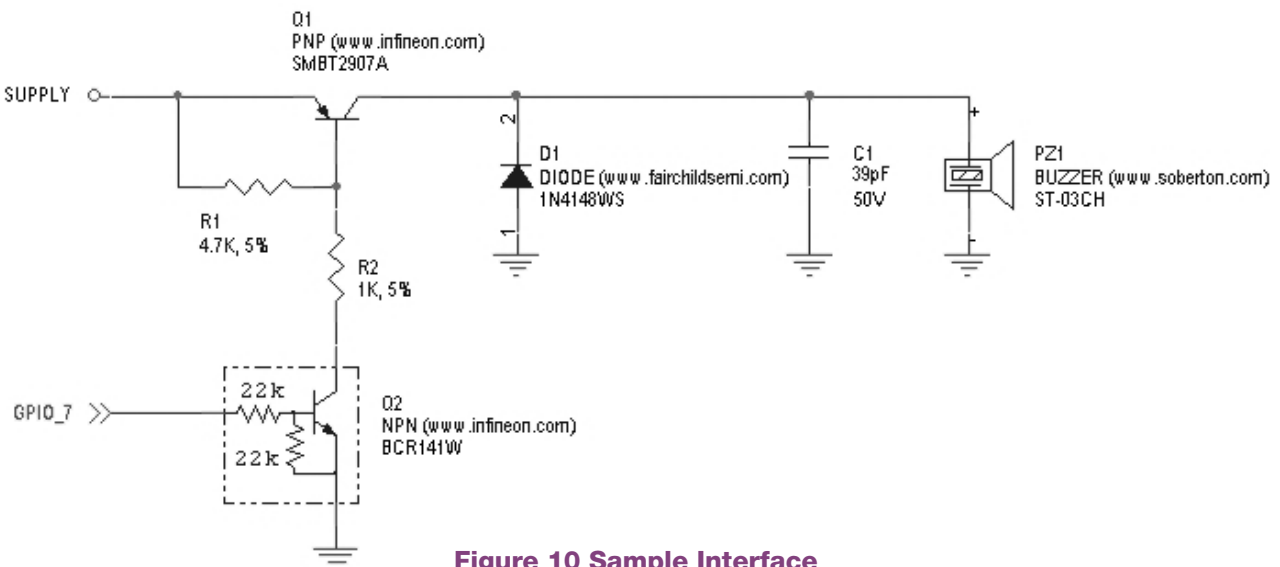

Figure 10 Sample Interface

NOTE: To correctly drive a buzzer, a driver must be provided. Its characteristics depend on the buzzer and are available from your buzzer vendor.

9.6.5 Analog to Digital Converter

ADC	Description
1	Analog to digital converter input
2	Analog to digital converter input

9.6.6 I2C

The I2C interface is an alternate function of the modem's GPIO, for the HSPA910CF, EVDO910CF, and CDMA910CF those two signals are designated for GPIO 9 (SDA) and GPIO 10 (SCL) and are 1.8V logic level to match the DVI interface for easy usage with a codec. The signals are not pulled up on the Plug-In module and must be pulled up externally as they may also be used as spare GPIO.

Please reference the Telit AT Command Guide for details on the I2C commands.

9 Interfaces continued

9.6 GPIO Details continued

9.6.7 ENABLE Pin

Input Logic State	Description
High-Z	Active state
0	Shutdown

Notes:

1. It is required that this input be controlled by an open collector/drain output. Do not use an external pull-up resistor, a pull-up to VIN is included internal to the Terminus.
2. The ENABLE pin is offered as a means to turn off the on-board regulator for when a full power cycle is needed or an ultra low power state is required. The ENABLE pin is not intended to be used as a means of turning the Terminus off. Use the ON/OFF pin to turn the Terminus on or off.
3. Shut down state must be held for 10ms before returning to active state.
4. The regulator is operational 2mS after active state is entered.

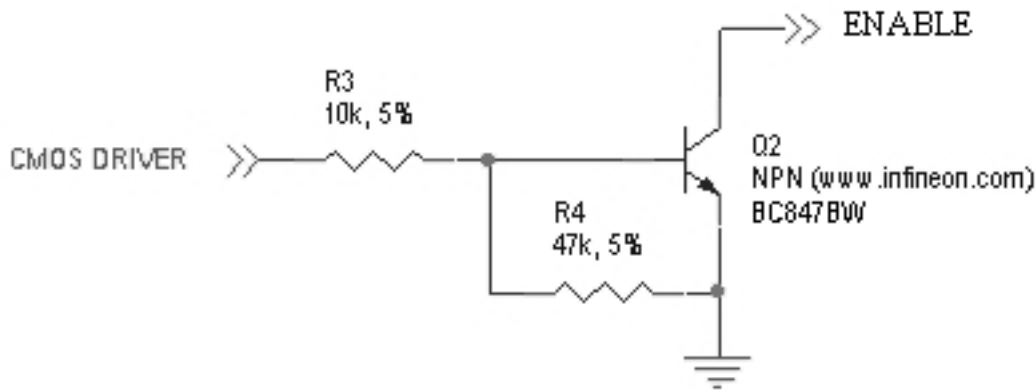

Figure 11 Enable Pin

9.6.8 RESET Pin

Input Logic State	Description
High-Z	Active state
0	Reset state

Notes:

1. It is required that this input be controlled by an open collector/drain output. Do not use an external pull-up resistor, a pull-up is included internal to the Terminus.
2. The RESET pin is offered as a means to reset the Terminus when and if the Terminus becomes unresponsive. The RESET pin is not intended to be used as a means of turning the Terminus off. Use the ON/OFF pin to turn the Terminus on or off.
3. RESET state must be held for at least 200ms before returning to active state.

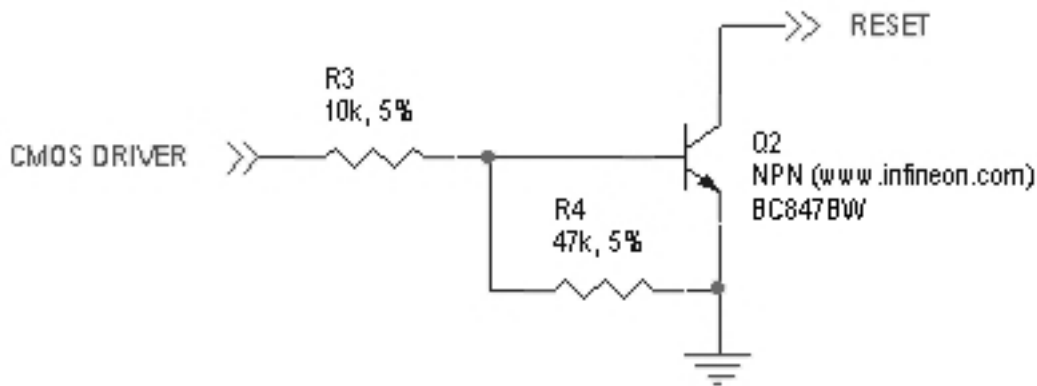

Figure 12 Reset Pin Diagram

9 Interfaces continued

9.6 GPIO Details continued

9.6.9 ON/OFF Pin

Input Logic State	Description
High-Z	Terminus turned ON or OFF after input returns to this state.
0	Toggle Terminus ON or OFF

Notes:

1. It is required that this input be controlled by an open collector/drain output. Do not use an external pull-up resistor, a pull-up is included internal to the Terminus.
2. The ON/OFF pin is offered as a means to power-on and power-down the Terminus. When the Terminus powers-down it informs the cell tower that it is powering down and will not be communicating with the tower any more. This is considered a controlled power-down.
3. After toggling the power state of the Terminus, wait until PWRMON indicates chosen state before toggling the power state again.
4. To turn ON the plug-in module, the ON_OFF input must be tied low for at least 3 second then released.
5. To turn OFF the plug-in module, the ON_OFF input must be tied low for at least 2 seconds then released.
6. Optionally the Terminus may be powered-down with the use of AT commands.
7. It is required to stop driving terminal inputs high when turning ON the Plug-In module by floating or bringing them low. If this is not done, power sequencing issues may occur.

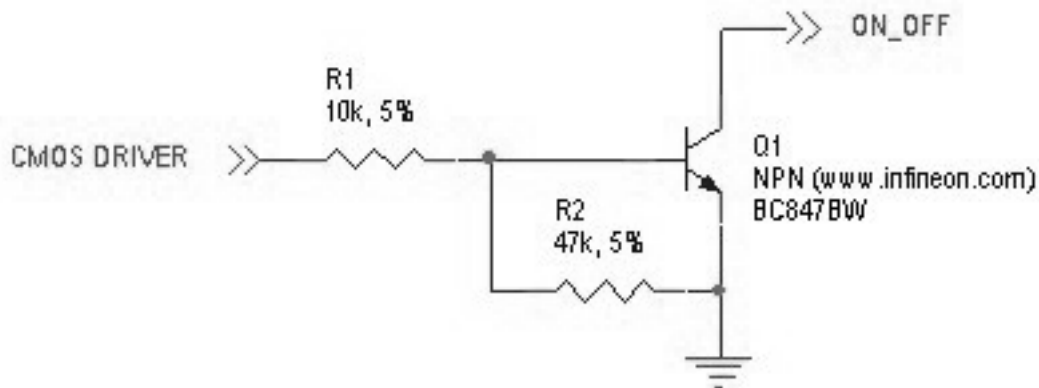

Figure 13 On / Off Pin Diagram

9.6.10 PWRMON Pin

Output Logic State	Description
0	Terminus powered-down
1	Terminus powered-on

Notes:

1. Used in conjunction with ON/OFF pin to control power-on and power-down state.
2. During a power down, it is required to stop driving terminal inputs high by floating or bringing them low. If this is not done, the PWRMON output will not transition low. On the GSM865CF and HSPA910CF, this will cause the VAUX output to remain active.

9.6.11 VAUX

A regulated power supply output that is provided in order to supply small devices from the module itself.

Note:

1. In the case of the GSM865CF, HSPA910CF, EVDO910CF, and CDMA910CF, VAUX will be ON when PWRMON is HIGH, and OFF when PWRMON is LOW. In the case of the CDMA864CF and UMTS864CF, VAUX is controlled via AT commands.

9.6.12 SERVICE

This service pin can be used to upgrade the module from ASC1 (TRACE RX, TRACE TX). The pin shall be tied low to enable the feature only in case of a Reflashing activity.

Note: Control this input in an open collector configuration only.

9 Interfaces continued

9.7 Internal Interfaces

The following section describes all signals that are exposed internally for control of the Terminus.

9.7.1 GPS Reset (GSM865CF)

When using a GPS enabled Terminus GSM865CF terminal, GPIO 9 is internally connected to the RESET input of the MS20 GPS module. This allows the application to reset the GPS receiver to a power-on state. The terminal pin GPS RESET can also reset the MS20, but must be controlled via an open-drain output. The MS20 has an internal pull-up resistor thus GPS RESET must not implement an external pull-up resistor.

Input Logic State	Description
0	GPS module in reset state
1	GPS module in run state

9.7.2 GPS Suspend (GSM865CF)

When using a GPS enabled Terminus GSM865CF terminal, GPIO 8 is internally connected to the SUSPEND input of the MS20 GPS module. This allows the application to set the GPS receiver into a suspended mode of operation to reduce current draw when the GPS receiver is not needed.

Input Logic State	Description
0	GPS module in suspended state
1	GPS module in run state

9.7.3 GPS Enable (GSM865CF)

When using a GPS enabled Terminus GSM865CF terminal, GPIO 10 is internally connected to the LDO_EN input of the MS20 GPS module. This allows the application to set the GPS receiver into the lowest possible current draw when the GPS receiver is not needed.

Input Logic State	Description
0	GPS module is disabled
1	GPS module in run state

9.7.4 GPS LED (GSM865CF)

When using a GPS enabled Terminus GSM865CF terminal, the MS20 GPS receiver controls the GPS_LED output. See Figure 10 for recommended connection of LED.

9.7.5 GPS LED (CDMA864CF & UMTS864CF)

The CDMA864CF & UMTS864CF terminals come equipped with GPS functionality that is built into the cellular radios. However, the cellular radios have no GPS status output for driving an LED. Instead, these modules have GPIO21 connected to the GPS LED pin of the Terminus. The user application can use this to control an LED or act as an additional GPIO. See Figure 10 for recommended connection of an LED.

9.7.6 GPS LED (HSPA910CF, EVDO910CF, & CDMA910CF)

The HSPA910CF, EVDO910CF, & CDMA910CF terminals comes equipped with GPS functionality that is built into the cellular radios. The cellular radios have no GPS output for driving an LED. This module has GPIO2 connected to the GPS LED pin of the Terminus terminal. The user application can use this to control an LED or act as an additional GPIO. See Figure 10 for recommended connection of LED.

9 Interfaces continued

9.8 LED Status Indicators

The LED Status outputs are used to drive external LEDs and their status is defined below. See Figure 10 for recommended connection of LED. For the HSPA910CF, EVDO910CF, and CDMA910CF, the Cellular LED Status is an alternate function of GPIO1. Please see the AT command reference for how to access alternate functions of the GPIO to allow this feature.

9.8.1 Cellular LED Status (GSM865CF, CDMA864CF, UMTS864CF, EVDO910CF, CDMA910CF)

LED Status	Device Status
Permanently Off	Cellular radio is off
Fast Blinking (0.5 sec on / 0.5 sec off)	Net search/ not registered/turning off
Slow Blinking (0.3 sec on / 2.7 sec off)	Registered, full service
Permanently On	A call is active

9.8.2 Cellular LED Status (HSPA910CF)

LED Status	Device Status
Permanently Off	Cellular radio is off
Permanently On	On/Searching
Slow Blinking (0.3 sec on / 2.7 sec off)	Registered
Fast Blinking (0.5 sec on / 0.5 sec off)	Shutting down

9.8.3 GPS (GSM865CF)

LED Status	Device Status
Permanently Off	No power to unit, GPS not installed
Fast Blinking (1.0 sec on / 1.0 sec off)	No fix, searching
Slow Blinking (1.0 sec on / 4.0 sec off)	Location fix

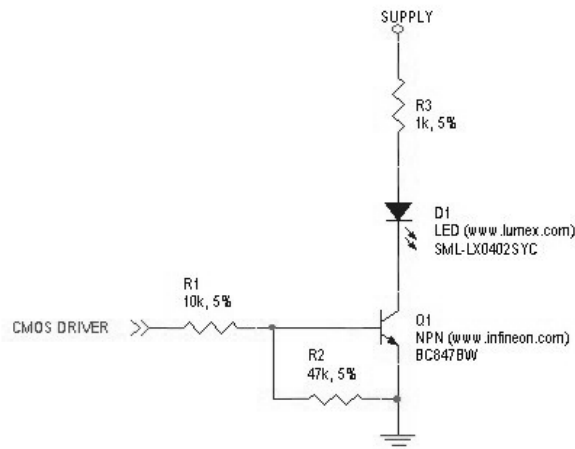

Figure 14 LED Indicators Diagram

9 Interfaces continued

9.9 RF Interface

There are 3 possible RF interfaces on the Terminus Plug-in Modules. The non-GPS GSM865CF has only the cellular antenna jack. The GSM865CF (GPS Enabled), UMTS864CF, and CDMA864CF have both cellular and GPS antenna interfaces. The HSPA910CF (GPS Enabled) has the cellular, RX diversity, and GPS antenna jacks. The specifications and requirements for these are as follows:

Note: You must access the Cellular/Div/GPS connections via the SMT GSC connections if they do not include a GSC to SMA connector. These signals are NOT electrically connected elsewhere on the board.

9.9.1 Cellular Antenna

9.9.1.1 GSM865CF Antenna Interface:

Type: Murata GSC - MALE (Murata Part #MM9329-2700RA1)

Pin	Description
Center Pin	RF signal
Outer Conductor	Signal ground

9.9.1.2 Certified GSM Antenna

TBD

9.9.1.3 CDMA864CF Antenna Interface

This module includes coax GSC to SMA (F) bulkhead connector that is mounted to the plug-in module.

Type: GSC to SMA (F), 200mm Cable (Janus Part #MC-0168)

Pin	Description
Center Pin	RF signal
Outer Conductor	Signal ground

9.9.1.4 Certified CDMA Antenna

(Janus Part number ANT-0073-G)

Frequency:	824-894 MHz, 1850-1990 MHz
Gain:	3 dBi
VSWR:	2:1 max
Impedance:	50 Ω nominal
Power:	5W max
Operating Temperature:	-40°C to 85°C
Length:	6.75" with 90° angle; 7.75" when straight

9.9.1.5 UMTS864CF Antenna Interface

This module includes coax GSC to SMA (F) bulkhead connector that is mounted to the plug-in module.

Type: GSC to SMA (F), 200mm Cable (Janus Part #MC-0168)

Pin	Description
Center Pin	RF signal
Outer Conductor	Signal ground

9.9.1.6 Certified UMTS Antenna

TBD

9 Interfaces continued

9.9 RF Interface continued

9.9.1.7 HSPA910CF Antenna Interface

Type: Murata GSC - MALE (Murata Part #MM9329-2700RA1)

Pin	Description
Center Pin	RF signal
Outer Conductor	Signal ground

9.9.1.8 Certified HSPA+ Antenna

TBD

9.9.1.9 EVDO910CF Antenna Interface

Type: Murata GSC - MALE (Murata Part #MM9329-2700RA1)

Pin	Description
Center Pin	RF signal
Outer Conductor	Signal ground

9.9.1.9 Certified EV-DO Antenna

TBD

9.9.1.10 Cellular Antenna Installation Guidelines

- Install the antenna in a place covered by the cellular provider of your choice.
- The antenna must be installed to provide a separation distance of at least 20 cm from all persons and must not be co-located or operated in conjunction with any other antenna or transmitter.
- Antenna must not be installed inside metal cases
- Antenna must be installed also according to antenna manufacturer instructions.
-

9.9.2 GPS Antenna Specifications:

9.9.2.1 GPS Antenna Interface

Type: Murata GSC - MALE (Murata Part #MM9329-2700RA1)

Pin	Description
Center Pin	RF Signal, Supplies voltage to power active antenna
Outer Conductor	Signal ground

9.9.2.2 GPS Antenna Installation Guidelines:

- Install the antenna with a clear sky view.
- Antenna must not be installed inside metal cases
- Antenna must be installed also according to antenna manufacturer instructions.

9 Interfaces continued

9.10 SIM Card Interface

GSM865CF, UMTS864CF and HSPA910CF

The SIM Card Interface allows the Terminus to accept the subscriber card provided by the cellular telephone provider.

It can accommodate a 1.8V or 3.0V SIM card and complies with the Phase 2 GSM 11.14 standard. Optional SIM IC. Consult factory representative.

9.11 Header Interface Mounting Options

The Plug-In Modules' header pin length has been chosen to allow for direct solder mount to a PCB of standard thickness. If the user wishes to socket the Plug-In Module, they may do so as well by using the below part numbers for reference:

Samtec 25 pin header: TSM-125-04-L-SV-A

Samtec 24 pin header: TSM-124-04-L-SV-A

Mating Samtec 25 pin connector: SLW-125-01-G-S

Mating Samtec 24 pin connector: SLW-124-01-G-S

Please note there are no Samtec SMT single row mating connectors. The only mating connector available is the above listed THT version.

9.12 Screw Mounting

The xxxx910CF family allows for the use of a #4 machine screw to help keep a socketed module in place where environmental variables may cause problems otherwise. If the user wishes to have a stand-off underneath the module to help alleviate possible stress from mounting hardware, below are the Janus part numbers and associated drawings for an available solution.

4-40 Hex Female Stand-off: MC-0356-G

4-40 3/16" Pan Head Phillips Machine Screw: MC-0357-G

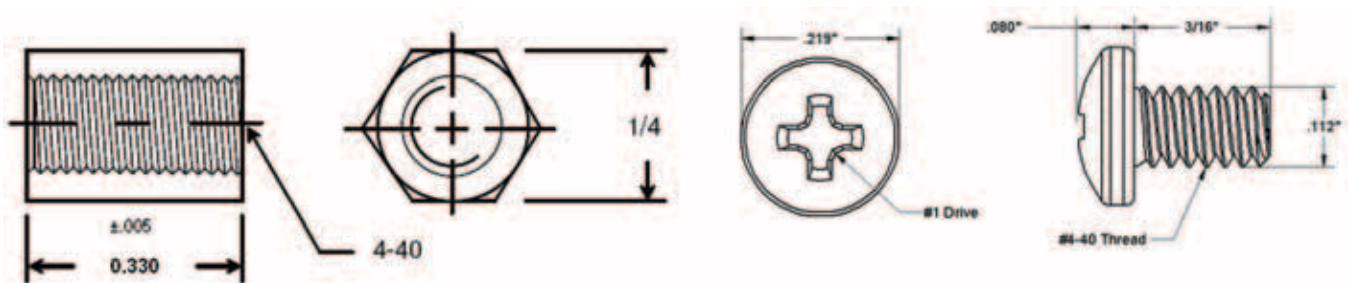

Figure 15 Screw Diagram

10 GSM865CF TECHNICAL SPECIFICATIONS

10.1 Electrical Specifications

10.1.1 Absolute Maximum Ratings

Parameter	Min	Typ	Max	Unit	Note
VIN (DIGITAL INPUTS 2.8V CMOS)	-0.3	-	3.1	Volt	
VIN (DIGITAL INPUTS 1.8V CMOS)	-0.3	-	2.1	Volt	
VIN (ANALOG INPUT)	-0.3	-	3.0	Volt	
Storage Temperature	-40	-	85	°C	
Supply (+) referenced to Supply(-)	0	-	16	Volt	

Operation of the device at these or any other conditions beyond those listed under Recommended Operating Conditions is not implied. Exposure to Absolute Maximum Rating conditions for extended periods of time may affect device reliability.

10.1.2 Recommended Operating Conditions

Parameter	Min	Typ	Max	Unit	Note
Temperature without GPS	-40	-	80	°C	
Temperature with GPS	-30	-	65	°C	
Supply (+) referenced to Supply (-)	4.75	-	5.25	Volt	
VAUX Output	-	2.8	-	Volt	
VAUX Current	-	-	100	mA	

10.1.3 Power Supply

Mode	Average (mA)	Mode Description
POWERED DOWN		
Terminal Disabled	≤ 0.015 *	Terminal disabled (ENABLE SUPPLY = 0)
Cellular Radio Off	1.4 *	Cellular module powered but switched off via ON_OFF pin (PWRMON=0)
IDLE MODE		
AT+CFUN=1	25 *	Normal mode: full functionality of the module
AT+CFUN=4	24 *	Disabled TX and RX; module is not registered on the network
AT+CFUN=0 or =5	5.3 *	Power saving; module registered on the network and can receive voice call or SMS.
GSD TX and RX mode		
GSM900 CSD PL5	313.0	GSM voice call
DCS1800 PL0	214.0	
GPRS (class 10) 1TX		
GSM900 PL5	271.0	GPRS sending data mode
DCS1800 PL0	181.0	
GPRS (class 10) 2TX		
GSM900 PL5	486	GPRS sending data mode
DCS1800 PL0	316	
MS20 GPS Power		
During acquisition (fully active)	TBD	
While tracking (fully active)	TBD	

* Advanced Data

10 GSM865CF TECHNICAL SPECIFICATIONS continued

10.1 Electrical Specification continued

10.1.4 I/O Levels

10.1.4.1 Standard Interface Levels

Parameter	Min	Typ	Max	Unit	Note
Input Voltage High - Vih	2.1	-	3.0	Volt	
Input Voltage Low - Vil	0	-	0.5	Volt	
Output Voltage High - Voh	2.2	-	3.0	Volt	
Output Voltage Low - Vol	0	-	0.35	Volt	
Typical Current Source/Sink capability = 1mA/1uA					

10.1.4.2 Cellular LED Output Levels

Parameter	Min	Typ	Max	Unit	Note
Output Voltage High - Voh	1.65	-	2.0	Volt	
Output Voltage Low - Vol	0	-	0.35	Volt	
Typical Current Source = 1mA					

10.1.4.3 Reset Pin Input Levels

Parameter	Min	Typ	Max	Unit	Note
Input Voltage High - Vih	1.8	-	2.1	Volt	
Input Voltage Low - Vil	0	-	0.2	Volt	

It is required that this input be controlled by an Open Collector/Drain Output. Do not use an external pull-up resistor, a pull-up is included internal to the Terminus.

10.1.4.4 ADC Levels - ADC1 & ADC2

Parameter	Min	Typ	Max	Unit	Note
Voltage Range	0	-	2.0	Volt	
AD Conversion	-	-	11	Bits	
Resolution	-	-	< 1	mV	

10.1.4.5 DAC Levels - DAC

Parameter	Min	Typ	Max	Unit	Note
Output Voltage Range	0	-	2.6	Volt	
DAC Conversion	-	-	10	Bits	
Step Range	0	-	1023	mV	

Notes

1. DAC output must be integrated (for example with a low band pass filter) in order to obtain an analog voltage. The precision is 1023 steps. If we consider that the maximum voltage as 2.6V, the integrated voltage could be calculated with the following formula: $\text{Integrated output voltage} = (2.6 \times \text{step})/1023$
2. See Figure 11 for recommended low pass filter

10.1.4.6 GPS Interface Levels (NavSync MS20)

Parameter	Min	Typ	Max	Unit
Input Voltage High - Vih	2.5	-	-	Volt
Input Voltage Low - Vil	-	0.8	1.0	Volt
Output Voltage High - Voh	2.9	-	-	Volt
Output Voltage Low - Vol	-	-	0.1	Volt

Typical Current Source/Sink Capability = 4mA/1uA

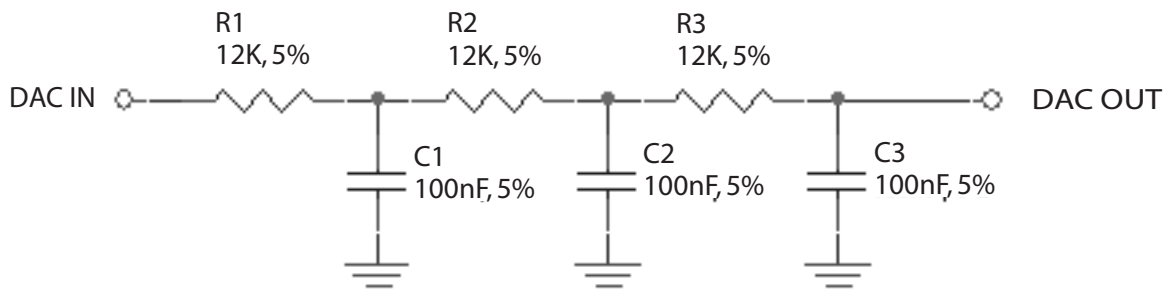

Figure 16 Required DAC Filter

10 GSM865CF TECHNICAL SPECIFICATIONS continued

10.1 Electrical Specification continued

10.1.5 GSM Cellular Antenna Interfaces

10.1.5.1 Antenna Specifications:

Frequency Range	GSM850: TX: 824.2 - 850.0Mhz GSM900 Primary: TX: 890.2 - 914.8Mhz GSM900 Extended: TX: 880.2 - 889.8Mhz PCS1900: TX: 1850.2 - 1909.8Mhz	RX: 869.2 - 895.0Mhz RX: 935.2 - 959.8Mhz RX: 925.2 - 934.8Mhz RX: 1930.2 - 1989.8Mhz
Bandwidth	70MHz in GSM850, 80 MHz in GSM900, 170 MHz in DCS, 140 MHz in PCS band	
Gain	1.4 dBi @ 900 MHz, 3dBi @ 1800 MHz, 1.4 dBi @ 850 MHz, 3dBi @ 1900 MHz	
Impedance	50 Ω	
Input Power	>2 W peak power	
VSWR absolute max	$\leq 10:1$	
VSWR recommended	$\leq 2:1$	

10.1.6 GSM GPS Antenna Interfaces

10.1.6.1 Antenna Specifications

Input Voltage Range	2.9V $\pm 5\%$
Frequency Range	1575.42 ± 3 MHz
Gain	Depends on cable type and length
Impedance	50 Ω
VSWR	$\leq 1.5:1$
Current Consumption	30 mA (MAX), 20 mA TYP

Note: GSM865CF GPS antenna interface only available by option, otherwise not populated

10.1.7 Input / Output Lines

Input Lines (MIC + & MIC-)

Parameter	GSM865CF
Line Coupling	AC (*)
Line Type	Balanced
Coupling Capacitor	≥ 100 nF
Differential Input Impedance	50 k Ω
Differential Input Voltage	$\leq 1,03$ Vpp @ HSMicG = 0 dB
Volume Steps	7
Volume Level Step	6 dB/Step

*Warning: The line coupling definition "AC" means that the signals from the microphone must be connected to the input lines of the module through capacitors, not less than 100 nF. By not respecting this constraint, the input stage may be damaged.

Output Lines (EAR+ & EAR-)

Parameter	GSM865CF
Line Coupling	DC
Output Load Impedance	≥ 14 Ω
Differential Output Impedance	4 Ω
Signal Bandwidth	150-4000 Hz @ -3 dB
Differential Output Voltage (max)	1.31 Vrms (open circuit)
Volume Steps	10
Volume Level Step	2 dB/Step

10 GSM865CF TECHNICAL SPECIFICATIONS continued

10.3 MS20 GPS Specifications

10.3.1 Features:

- High sensitivity of -159 dBm in tracking & -144 dBm in acquisition
- Assisted/Autonomous operation
- 12 channels
- SBAS (WASS/EGNOS/MSAS)

10.3.2 Specifications:

Specifications	Description	Notes	
GPS Channels	12 tracking (48 acquisition)		
Frequency	1575.42 MHz – L1 C/A Code		
TTF Cold Start	34 seconds	1,7	
TTF Warm Start	32 seconds	1,7	
TTF Hot Start	1.5 seconds	1,7	
Re-Acquisition Time	<1 second	2	
Acquisition Sensitivity (fix not available)	TTF (Hot) with all signals at -138 dBm: 30 s	3	
Acquisition Sensitivity (dBm)	-144 dBm	4	
Tracking Sensitivity (dBm)	-159 dBm	5	
Acquisition Sensitivity SBAS Satellites (dBm)	TBD	6	
Tracking Sensitivity SBAS Satellites (dBm)	TBD	6	
Static Accuracy (without SBAS)	50% confidence (CEP)	1.7 m	7
	95% confidence	2.9 m	
Static Accuracy (with SBAS)	50% confidence (CEP)	1.2 m	8
	95% confidence	2.4 m	
Maximum Horizontal Speed	515 m/s (1000 Knots)	9	
Maximum Altitude	18 Km (60000 feet)	9	
Maximum Acceleration, Jerk	4 g, 7 g/s		

Notes:

1. These are RMS values
2. Maximum sensitivity -147 dBm
3. Simulator test, all signals at specified power level
4. Estimated
5. Simulator test, continuous fix with all signals at specified power level
6. Simulator test with signal at specified power level
7. Open-sky, 24 hrs statistic, active antenna (signal range between 30 and 49 dB/Hz)
8. Open sky, 24 hrs statistic, active antenna (WAAS signal used)
9. Limited by International Traffic in Arms Regulation (ITAR)

10 GSM865CF TECHNICAL SPECIFICATIONS continued

10.4 GSM865CF Getting Started

10.4.1 Setting Up A Terminal Emulator For Use With The GSM865CF Terminus

10.4.1.1 Set Up

To interface with the module, connect the serial interface to a PC and use a terminal emulation program such as Microsoft® Hyperterminal. Set the interface parameters as follows:

- Baud Rate: 115.2 kbps
- Bits: 8
- Stop Bits: 1
- Parity: None
- Hardware Handshaking: Yes

10.4.1.2 Set The Terminal to Auto-Bauding

- Enter AT<cr> from terminal and wait for OK
- Enter AT+IPR=0<cr> and wait for OK
- Terminus is now set for auto data rate detection

10.4.1.3 Verify Your Terminal and Firmware Version

- Enter AT+CGMM and wait for the response
The response will be the Telit module's model number without a command echo.
- Enter AT+CGMR and wait for the response
The response will be the Telit module's current firmware without a command echo.

Please confirm your model and firmware with the one listed in section 2.1

10.4.2 Powering ON/OFF

10.4.2.1 Turn the module ON through the following method:

- Pull ON/OFF signal (Pin 19) to ground for three (3) seconds, then release.

The Terminus module is fully operational after 4 seconds. Logging onto a network may take longer than this and is outside the control of the Terminus.

10.4.2.2 There are two ways to switch OFF the module as described below.

- Use the appropriate AT command (AT#SHDN)
- Pull ON/OFF signal (Pin 19) to ground for two (2) seconds, then release.

10 GSM865CF TECHNICAL SPECIFICATIONS continued

10.4 GSM865CF Getting Started continued

10.4.3 Setting up Service – Network Settings

10.4.3.1 Set Up

The network settings for the Terminus will vary depending on the cellular carrier you are using. Below are two of the North American cases for these settings.

For T-mobile® & MNVO (Raco®, Sensor Logic®, Nexaira® Jasper Wireless®) Enter:

- AT#SELINT=2 //use of most recent AT command set
- AT#STIA=2,10 or AT#STIA=1 // enable SAT – SIM Application Tool-Kit
- AT#BND=3 // default bands to 850/1900
- AT#AUTOBND=1 // enable Quad band system selection
- AT#PLMNMODE=1 // enable EONS (enhanced operator naming scheme)
- AT&P0 // save profile
- AT&W0 // save setting
- AT#ENS=0

For AT&T/Cingular® & MNVO (Kore®, Aeris®, nPhase®) Enter:

- AT#SELINT=2 //use of most recent AT command set
- AT#ENS=1 // AT&T/Cingular configuration (SAT, BND, AUTONBND, PLMNMODE, plus Cingular® specific ENS requirements)

If Terminus is being used in a different country or with a different carrier please refer to Telit AT command reference document regarding the use of the AT#BND command to set the proper frequency band.

Important: After entering either of the sets of settings above power the Terminus OFF and then ON. It is now ready for use.

10.4.3.2 Check Network Status (assuming you have a valid SIM card installed)

Enter AT+CREG? <cr> And wait for response.

Response will be +CREG:0,1 or +CREG: 0,5 meaning the device is registered to the home network or roaming, respectively. If response is different than this please refer to the Telit AT command reference document for more information.

10.4.3.3 Check Signal Quality

Enter AT+CSQ<cr> And wait for response +CSQ:<rss>,<ber>

<rss> Signal Strength
99 Not known or not detectable
0-31 dBm = (rss * 2) –113

Example: A result of 31 indicates -51dBm or greater.

An rssi value of >=10 in typical applications is fine and you will usually see about 12-20 in normal to good signal, but note that worst case it can be lower, still register and perform normal functions.

10.4.4 Making a Voice Call

10.4.4.1 Set Up

Voice call mode allows you to use a telephone handset to communicate with a properly equipped subscriber unit.

- Set the call mode to voice
Enter AT+FCLASS=8<cr> and wait for response OK
- Set the audio path of the Terminus
Enter AT#CAP=0
- Dial the phone number
Enter ATD <8885551234>; <cr>
- To disconnect the call enter ATH<cr>

10 GSM865CF TECHNICAL SPECIFICATIONS continued

10.4 GSM865CF Getting Started continued

10.4.5 Sending an SMS

10.4.5.1 Set Up

SMS (Select Message Service) mode allows you to send a text message (max 160 characters) to a SMS capable subscriber unit.

- Set the SMS mode to text. This must be entered every power cycle.
AT+CMGF=1<cr>
- To enter the receiving subscriber unit phone number and message enter:
AT+CMGS="8885551234"
Wait for response">" then enter message text
Enter "ctrl z" <cr> to end the message

10.4.6 Making a GPRS Data Call

10.4.6.1 Set Up

GPRS is a data service that uses Packet Data Protocol (PDP).

- Set up the PDP context parameters
Enter AT+CGDCONT=1, "IP", "APN", "0.0.0.0",0,0<cr>
Where APN is specific to the service provider being used.
- Set the minimum Quality of Service profile
Enter AT+CGQMIN=1,0,0,0,0
- Set up the desired Quality of Service profile
Enter AT+CGQREQ=1,0,0,3,0,0
- Activate the PDP context
Enter AT#SGACT=1,1,"v", "p"
Where v is your user ID and p is your password.
If these are not set replace with "", ""
- Open the socket connection
Enter AT#SD=1,0,IPP,IPA,0,0,0
Look for response "CONNECT". This opens a remote connection via socket
IPP = the remote host port of the server you are trying to connect to. (0 to 65535)
IPA = the IP address of the server you are trying to connect to in the format:
"xxx.xxx.xxx.xxx"
'Port'= the remote host port to contact provided by carrier (0 to 65535)
- At this point a data session is active and data can be sent from the Terminus to the remote device and visa versa.
- To exit the data session and return to command mode, send the characters"+++" and wait for the OK response
- Enter AT#SH=1 to close the socket

10.4.7 Making a GPS Data Call

10.4.7.1 Set Up

In order to access the GPS on the GSM865CF, the NavSync GPS port must be used. After connecting to that port, open a terminal window with the following parameters:

- Baud Rate: 9600 bps
- Bits: 8
- Stop Bits: 1
- Parity: None
- Hardware Handshaking: No

Simply open the port and an NMEA data stream will begin to appear. The specific commands to adjust this stream to the application are in the MS20 User Guide. Available in the evaluation kit CD or online at <http://www.janus-rc.com/gsm865cf.html>

10.4.8 Further Instructions

On utilizing different commands for other applications than those described here, please refer to these reference documents, listed in section 2.1

- Telit AT Commands Reference Guide
- Telit GC864 Software User Guide
- Telit Easy GPRS User Guide

11 CDMA864CF TECHNICAL SPECIFICATIONS

11.1 Electrical Specifications

11.1.1 Absolute Maximum Ratings

Parameter	Min	Typ	Max	Unit	Note
VIN (DIGITAL INPUTS 2.6V CMOS)	-0.3	-	3.0	Volt	
VIN (DIGITAL INPUTS 1.8V CMOS)	-0.3	-	2.1	Volt	
VIN (ANALOG INPUT)	-0.3	-	3.0	Volt	
Storage Temperature	-40	-	85	°C	
Supply (+) referenced to Supply (-)	0	-	16	Volt	

Operation of the device at these or any other conditions beyond those listed under Recommended Operating Conditions is not implied. Exposure to Absolute Maximum Rating conditions for extended periods of time may affect device reliability.

11.1.2 Recommended Operating Conditions

Parameter	Min	Typ	Max	Unit	Note
Temperature	-30	-	80	°C	
Supply (+) referenced to Supply (-)	4.75	-	5.25	Volt	
VAUX Output	-	2.65	-	Volt	
VAUX Current	-	-	100	mA	

11.1.3 Power Supply

Mode	Average (mA)	Mode Description
POWERED DOWN		
Terminal Disabled	< 15µA	Terminal disabled (ENABLE SUPPLY = 0)
Cellular Radio Off	1.4mA	Cellular module powered but switched off via ON_OFF pin (PWRMON=0)
Cellular	513	Transmission at max level (23 - 24Bm)
PCS	595	Transmission at max level (23 - 24 dBm)
Cellular	134	Transmission at min level (-50 dBm)
PCS	144	Transmission at min level (-50 dBm)
GPS ON		
Idle (AT+CFUN=1)	94	Normal mode: full functionality of the module
Sleep (AT+CFUN=4)	93	Disabled TX and RX; module is not registered on the network
Low Power (AT+CFUN=0 or 5)	N/A (Note 1)	Power saving: module registered on the network and can receive voice call or SMS
GPS OFF		
Idle (AT+CFUN=1)	46	Normal mode: full functionality of this module
Sleep (AT+CFUN=4)	45	Disabled TX and RX; module is not registered on the network
Low Power (AT+CFUN=0 or 5)	5	Power saving: module registered on the network and can receive voice call or SMS

Notes: The average current consumption during transmissions depends on the power level at which the device is requested to transmit by the network. Data taken with USB disconnected. The thermal design for the application and its power supply needs to take the following parameters into account.

Note 1: Low power mode is not usable with GPS ON (AT\$GPSP=1)

11 CDMA864CF TECHNICAL SPECIFICATIONS continued

11.1 Electrical Specifications continued

11.1.4 I/O Levels

11.1.4.1 Standard Interface Levels

Parameter	Min	Typ	Max	Unit	Note
Input Voltage High - Vih	1.69	-	2.9	Volt	
Input Voltage Low - Vil	-0.3	-	0.91	Volt	
Output Voltage High - Voh	2.15	-	2.6	Volt	
Output Voltage Low - Vol	0	-	0.45	Volt	
Typical Current Source/Sink capability = 1mA/1uA					

11.1.4.2 Cellular LED Output Levels

Parameter	Min	Typ	Max	Unit	Note
Output Voltage High - Voh	1.35	-	1.8	Volt	
Output Voltage Low - Vol	0	-	0.45	Volt	
Typical Current Source = 1mA					

11.1.4.3 Reset Pin Input Levels

Parameter	Min	Typ	Max	Unit
Input Voltage High - Vih	2.0	-	2.6	Volt
Input Voltage Low - Vil	0	-	0.2	Volt

It is required that this input be controlled by an Open Collector/Drain Output. Do not use an external pull-up resistor, a pull-up is included internal to the Terminus.

11.1.4.4 ADC Levels - ADC1 & ADC2

Parameter	Min	Typ	Max	Unit
Input Voltage Range	0	-	2.5	Volt
AD Conversion	-	-	8	Bits

11.1.4.5 DAC Levels - DAC

Parameter	Min	Typ	Max	Unit
Output Voltage Range	0	-	2.6	Volt
DAC Conversion	-	-	8	Bits
Step Range	0	-	255	Steps

Notes

1. DAC output must be integrated (for example with a low band pass filter) in order to obtain an analog voltage. The precision is 1023 steps. If we consider that the maximum voltage as 2.6V, the integrated voltage could be calculated with the following formula: Integrated output voltage = (2.6 x step)/1023
2. See Figure 11 for recommended low pass filter

11 CDMA864CF TECHNICAL SPECIFICATIONS continued

11.1 Electrical Specifications continued

11.1.5 CDMA Cellular Antenna

11.1.5.1 Antenna Specifications

Parameter	Descriptions
Frequency Range (CDMA)	TX: 824MHz – 849 MHz RX: 869MHz – 894 MHz
Frequency Range (PCS)	TX 1850MHz – 1910 MHz RX: 1930MHz – 1990MHz
Impedance	50 Ω
Recommended VSWR	< 2
Radiation Pattern	Omni-Directional
Polarization	Vertical

11.1.6 CDMA GPS Antenna Interfaces

11.1.6.1 Antenna Specifications

Parameter	Description
Input Voltage Range	4.0Vdc \pm 0.4Vdc
Frequency Range	1575.42 \pm 3 MHz
Gain	=< 16dB overall at the connector (Antenna and LNA included).
Impedance	50 Ω
VSWR	\leq 1.5:1
Current Consumption	30mA (MAX), 20 mA TYP

11.1.7 Input / Output Lines

Input Lines (MIC + & MIC-)

Parameter	CDMA864CF
Line Coupling	AC (*)
Line Type	Balanced
Coupling Capacitor	\geq 100 nF
Differential Input Impedance	20 k Ω
Differential Input Voltage	\leq 1,03 Vpp @ HSMicG = 0 dB
Volume Steps	7
Volume Level Step	TBD

**Warning: The line coupling definition "AC" means that the signals from the microphone must be connected to the input lines of the module through capacitors, not less than 100 nF. By not respecting this constraint, the input stage may be damaged.*

Output Lines (EAR+ & EAR-)

Parameter	CDMA864CF
Line Coupling	TBD
Output Load Impedance	TBD
Differential Output Impedance	TBD
Signal Bandwidth	TBD
Differential Output Voltage (max)	TBD
Volume Steps	TBD
Volume Level Step	TBD

11 CDMA864CF TECHNICAL SPECIFICATIONS continued

11.1 Electrical Specifications continued

11.1.8 USB Transceiver Specifications

Parameter	Comments	Min	Typ	Max	Unit
VBUS					
Supply voltage		4.4	5.0	5.6	Volt
Supply current				25	mA
Input levels for low-/full speed					
Input sensitivity (differential)	ID+ -D-I, Vin = 0.8 to 2.5 V	0.2	-	-	Volt
Common-mode range (diff)	Includes VDI	0.8	-	2.5	Volt
Receiver threshold	Single-ended	0.8	-	2.0	Volt
Receiver hysteresis	Single-ended	-	200	-	mV
Output Levels for low speed and full speed					
Logic low	RL= 1.5k to 3.6V	-	-	0.3	Volt
Logic high	RL = 15k to GND, IO = 1 mA	2.8	-	3.6	Volt
Output signal crossover voltage		1.30	-	2.00	Volt
Terminations					
High-Z state output impedance	0V < VDD < 3.6V; measured at D+ and D- pins to GND	300	-	-	kΩ
Transceiver output impedance	Active high or active low	6	-	18	Ω
Series output resistance	D+, D-	28	33	44	Ω
Internal pull-up resistor	VTRM to D+, VTRM to D-	1.425	1.500	1.575	kΩ
Internal pull-down resistor	D+ to GND, D- to GND	14.3	15.0	24.8	kΩ
Transceiver input capacitance	D+ and D- pins to GND	-	-	20	pF
Driver characteristics – full speed					
Transition time					
Rise time (tR)	CL = 50 to 125 pF	4	-	20	ns
Fall time (tF)	CL = 50 to 125 pF	4	-	20	ns
Rise/fall time matching		90	-	111	%
Series output resistance	D+, D-	28	33	44	Ω
Driver characteristics – low speed					
Transition time					
Rise time (tR)	CL = 50 to 600 pF	75	-	300	ns
Fall time (tF)	CL = 50 to 600 pF	75	-	300	ns
Rise/fall time matching		80	-	125	%
ID detection					
ID pin pull-up resistance		108	140	182	kΩ
A-device detection threshold	tdelay < 1 μs, V _{hys} = 50 mV	-	0.15* VTRM	-	Volt
B-device detection threshold	tdelay < 1 μs, V _{hys} = 50 mV	-	0.85* VTRM	-	Volt

11 CDMA864CF TECHNICAL SPECIFICATIONS continued

11.2 Mechanical Specifications

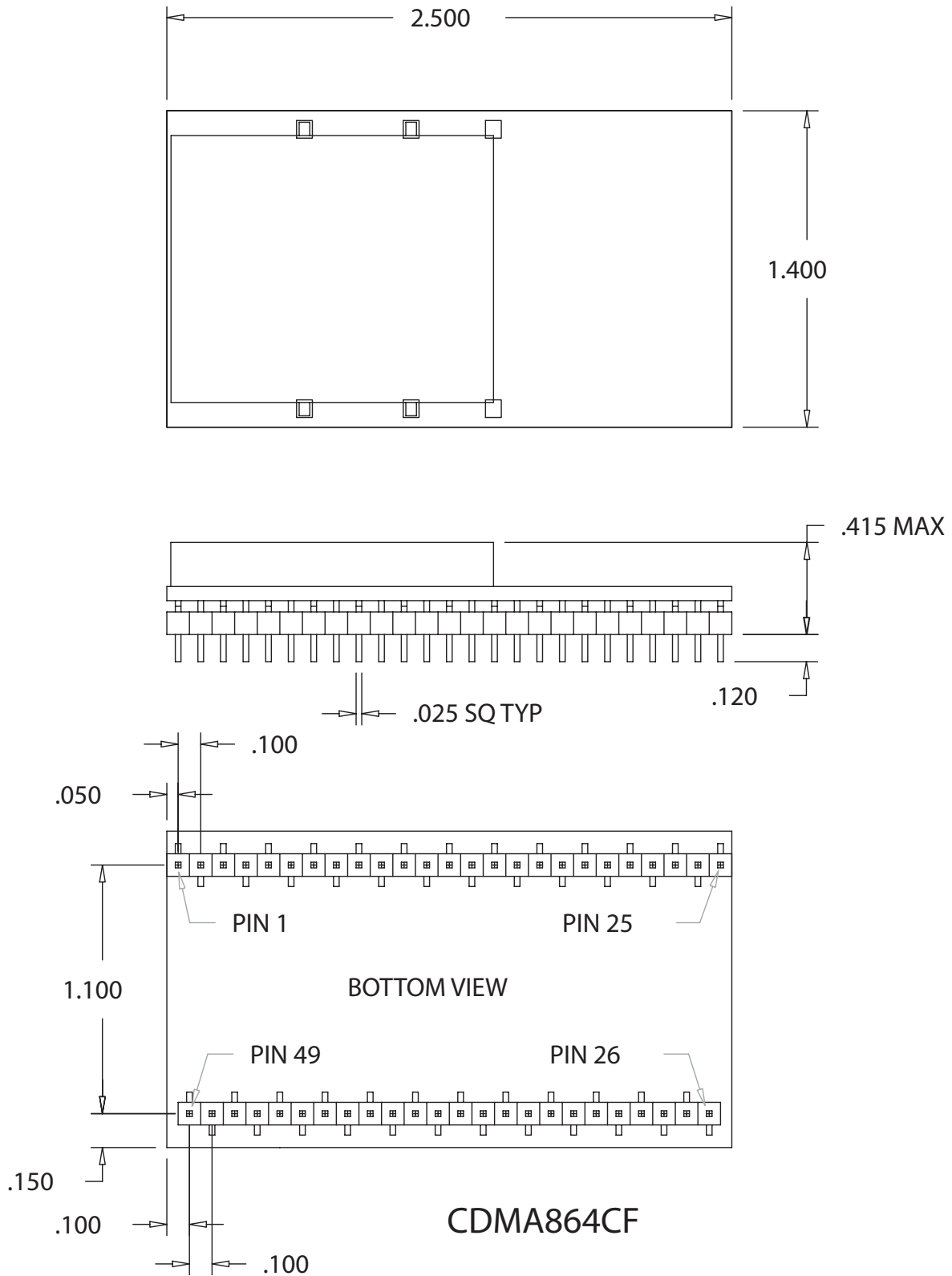

Figure 18 CDMA864CF Mechanical Dimensions

11 CDMA864CF TECHNICAL SPECIFICATIONS continued

11.3 Setting Up a Terminal Emulator For Use With The CDMA864CF Terminus

11.3.1 Set Up

To interface with the module, connect the serial interface to a PC and use a terminal emulation program such as Microsoft® Hyperterminal. Set the interface parameters as follows:

- Baud Rate: 115.2 kbps
- Bits: 8
- Stop Bits: 1
- Parity: None
- Hardware Handshaking: Yes
-

11.3.1.1 Test the Emulator Set Up

- Enter AT<cr> from terminal and wait for OK

Note that Autobaud is not supported on the CDMA864CF Terminus. If you are utilizing the serial interface and you wish to change the baud rate on the module, you must use AT+IPR. You must also change the rate in the host UART (i.e. HyperTerminal) to match the new baud rate. If these do not match you will not be able to send AT commands to the module through the serial port. The Terminus is by default set to 115.2 kbps.

11.3.1.2 Verify Your Terminal and Firmware version

- Enter AT+CGMM and wait for the response
- The response will be the Telit module's model number without a command echo.
- Enter AT+CGMR and wait for the response
- The response will be the Telit module's current firmware without a command echo.

Please confirm your model and firmware with the one listed in section 2.1

11.3.2 Powering ON/OFF

11.3.2.1 Turn The Terminal ON Through The Following Method:

- Pull ON/OFF signal (Pin 19) to ground for two (2) seconds, then release.

The Terminus module is fully operational after 4 seconds. Logging onto a network may take longer than this and is outside the control of the Terminus.

11.3.2.2 There Are Two Ways to Switch OFF the Terminal as Described Below.

- Use the appropriate AT command (AT#SHDN)
- Pull ON/OFF signal (Pin 19) to ground for two (2) seconds, then release.

11 CDMA864CF TECHNICAL SPECIFICATIONS continued

11.3 CDMA864CF GETTING STARTED continued

11.3.3 Setting Up Service

11.3.3.1 Provisioning the Plug-In Terminus

To provision the unit, you will need to contact Sprint, Verizon, Aeris, or an MVNO to set up a service contract.

Please see Janus Application Note Note 111: Provisioning Guide for Terminus M2M Devices

Contact information

Contact: Dave Jahr, Janus Remote Communications
djahr@janus-rc.com
630-499-2121

A terminal not provisioned will have the following characteristics.

11.3.4 Making a Voice Call

11.3.4.1 Set Up

Voice call mode allows you to use a telephone handset to communicate with a properly equipped subscriber unit.

- Set the call mode to voice
Enter `AT+FCLASS=0<cr>` and wait for response OK
- Set the audio path of the Terminus
Enter `AT#CAP=0`
- Dial the phone number
Enter `ATD <8885551234>; <cr>`
- To disconnect the call enter `ATH<cr>`

11.3.5 Sending an SMS

11.3.5.1 Set Up

SMS (Select Message Service) mode allows you to send a text message (max 160 characters) to a SMS capable subscriber unit.

- Set the SMS mode to text. This must be entered every power cycle.
`AT+CMGF=1<cr>`
- Set the text mode parameters. This is recommended as it will allow functionality of SMS on all networks.
`AT+CSMP="callback_address",4098,0,2`
The callback_address is the number of the provisioned module (MDN).
- If you wish to save your CSMP settings for easy entry in the future use the following commands:
`AT+CSAS`
To retrieve the saved settings, enter `AT+CRES`
- To enter the receiving subscriber unit phone number and message enter:
`AT+CMGS="8885551234"`
Wait for response ">" then enter message text
Enter "ctrl z" `<cr>` to end the message

11 CDMA864CF TECHNICAL SPECIFICATIONS continued

11.3 CDMA864CF GETTING STARTED continued

11.3.6 Establishing a Socket Connection (internet connectivity)

1. Enable Mobile IP

Issue AT command: AT\$QCMIP?

Expected Response: \$QCMIP:2

If response not expected issue AT command: AT\$QCMIP=2

2. Check if Context is active

Issue AT command: AT#SGACT?

Response of #SGACT=1,0 indicates context is not active.

Issue AT command: AT#SGACT=1,1

Note: If you activate context when already active you will receive an ERROR response.

3. Connect to GOOGLE http server via a TCP/IP Socket Connection

Issue AT command: AT#SD=1,0,80,www.google.com

Expected Response: CONNECT

A response of CONNECT indicates you are connected to Google's web site and the Terminal's serial port is in DATA mode.

Any data sent via the AT command serial port is sent to Google's server. Any data sent via Google's server is received on the terminal's AT command serial port.

4. Exiting Data Mode

Issue the following escape sequence via the AT command port: +++

Expected Response: OK

5. Close Open Socket Connection

Issue AT command: AT#SH=1

Expected Response: OK

11 CDMA864CF TECHNICAL SPECIFICATIONS continued

11.3 CDMA864CF GETTING STARTED continued

11.3.7 GPS

The GPS data can be acquired over the AT Command port with the following methods.

General commands for both methods 1 and 2:

Select Antenna Path:

Send command AT AT\$GPSPATH=1<CR>

Define Antenna Type:

Send command AT\$TPSAT=1<cr>

Method 1:

Send command AT\$GPSP=1<cr>

Send command AT\$GPSACP<cr>

\$GPSACP can retrieve GPS data at any point when \$GPSP=1

Method 2:

Configure Unsolicited NMEA Data:

Send command to enable NMEA stream

AT\$GPSNMUN=<enable><gga><gsa><gsv><rmc><vtg><cr>

Select parameter "1" to enable or "0" to disable for your NMEA stream requirements

EXAMPLE: AT\$GPSNMUN=3,1,1,1,1,1

Start NMEA Stream:

Send command AT\$GPSP=1<cr>

End NMEA Stream:

Send command AT\$GPSP=0<cr>

11.3.8 Further Instructions

On utilizing different commands for other applications than those described here, please refer to these reference documents, listed in section 2.1

- Telit CC864 AT Commands Reference Guide
- Telit CC864 Software User Guide

Please see Janus Application Note Note 111: Provisioning Guide for Terminus M2M Devices

12 UMTS864CF TECHNICAL SPECIFICATIONS

12.1 Electrical Specification

12.1.1 Absolute Maximum Ratings

Parameter	Min	Typ	Max	Unit	Note
VIN (DIGITAL INPUTS 2.6V CMOS)	-0.3	-	3.0	Volt	
VIN (DIGITAL INPUTS 1.8V CMOS)	-0.3	-	2.1	Volt	
VIN (ANALOG INPUT)	-0.3	-	3.0	Volt	
Storage Temperature	-40	-	85	°C	
Supply (+) referenced to Supply (-)	0	-	16	Volt	

Operation of the device at these or any other conditions beyond those listed under Recommended Operating Conditions is not implied. Exposure to Absolute Maximum Rating conditions for extended periods of time may affect device reliability.

12.1.2 Recommended Operating Conditions

Parameter	Min	Typ	Max	Unit	Note
Temperature	-30	-	80	°C	
Supply (+) referenced to Supply (-)	4.75	-	5.25	Volt	
VAUX Output	-	2.65	-	Volt	
VAUX Current	-	-	100	mA	

12.1.3 Power Supply

Mode	Average (mA)	Mode Description
POWERED DOWN		
Terminal Disabled	≤ 15µA	Terminal disabled (ENABLE SUPPLY = 0)
Cellular Radio Off	1.4	Cellular module powered but switched off via ON_OFF pin (PWRMON=0)
IDLE MODE		
IDLE mode with GPS OFF		
AT+CFUN=1	WCDMA 26 GSM 23	Standby mode; no call in progress: GPS OFF Normal mode: full functionality of the module
AT+CFUN=4	WCDMA 20 GSM 20	Disabled TX and RX; module is not registered on the network
AT+CFUN=0	WCDMA 5 GSM 5	Power saving; CFUN=0 module registered on the network and can receive voice call or an SMS; but it is not possible to send AT commands; module wakes up with an unsolicited code (call or SMS) or rising RTS line.
AT+CFUN=5	WCDMA 5 GSM 5	CFN=5 full functionality with power saving; Module registered on the network can receive incoming call sand SMS
WCDMA TX and RX mode with GPS OFF		
WCDMA Voice	708	WCDMA voice channel
WCDMA data	697	WCDMA data channel
HSDPA	749	HSDPA data channel (HSDPA for UC864-E/G only)
GSM TX and RX mode with GPS OFF		
GSM Voice	328	GSM voice channel
GPRS Class 12	810	GPRS data channel
EDGE Class 12	574	EDGE data channel
UC864-G only		
IDLE mode with GPS ON full power mode*		
AT+CFUN=1	WCDMA 135 GSM 120	Standby mode; no call in progress: GPS ON
AT+CFUN=4	WCDMA 115 GSM 115	Disabled TX and RX; module is not registered on the network
WCDMA TX and RX mode with GPS ON full power mode*		
WCDMA Voice	785	WCDMA voice channel
WCDMA	775	WCDMA data channel
HSDPA	825	HSDPA data channel
GSM TX and RX mode with GPS ON full power mode*		
GSM Voice	410	GSM voice channel
GPRS Class 12	880	GPRS data channel
EDGE Class 12	650	EDGE data channel

* except external active GPS antenna

12 UMTS864CF TECHNICAL SPECIFICATIONS continued

12.1 Electrical Specification continued

12.1.4 I/O Levels

12.1.4.1 Standard Interface Levels

Parameter	Min	Typ	Max	Unit	Note
Input Voltage High - Vih	2.0	-	2.9	Volt	
Input Voltage Low - Vil	-0.3	-	0.6	Volt	
Output Voltage High - Voh	2.2	-	2.6	Volt	
Output Voltage Low - Vol	0	-	0.35	Volt	

Typical Current Source = 1mA

12.1.4.2 Cellular LED Output Levels

Parameter	Min	Typ	Max	Unit	Note
Output Voltage High - Voh	1.4	-	1.8	Volt	
Output Voltage Low - Vol	0	-	0.35	Volt	

Typical Current Source = 1mA

12.1.4.3 Reset Pin Input Levels

Parameter	Min	Typ	Max	Unit	Note
Input Voltage High - Vih	2.0	-	2.6	Volt	
Input Voltage Low - Vil	0	-	0.2	Volt	

It is required that this input be controlled by an Open Collector/Drain Output. Do not use an external pull-up resistor, a pull-up is included internal to the Terminus.

12.1.4.4 ADC Levels - ADC1 & ADC2

Parameter	Min	Typ	Max	Unit	Note
Input Voltage Range	0	-	2	Volt	
AD Conversion	-	-	8	Bits	
Resolution	-	-	< 10.2	mV	

12.1.4.5 DAC Levels - DAC

Parameter	Min	Typ	Max	Unit	Note
Output Voltage Range	0	-	2.6	Volt	
DAC Conversion	-	-	10	Bits	
Step range	0	-	1023	Steps	

Notes

1. DAC output must be integrated (for example with a low band pass filter) in order to obtain an analog voltage. The precision is 1023 steps. If we consider that the maximum voltage as 2.6V, the integrated voltage could be calculated with the following formula: $\text{Integrated output voltage} = (2.6 \times \text{step})/1023$
2. See Figure 11 for recommended low pass filter

12 UMTS864CF TECHNICAL SPECIFICATIONS continued

12.1 Electrical Specification continued

12.1.5 UMTS Cellular Antenna Specifications:

12.1.5.1 Antenna Specifications

Parameter	Description
Frequency Range	Depending on frequency bands provided by the network operator, the customer should use the most suitable antenna for those frequencies.
Bandwidth	70MHz in GSM850 80 MHz in GSM900 170 MHz in DCS & 140 MHz PCS 70 MHz in WCDMA850 140 MHz in WCDMA1900 250 MHz in WCDMA2100 band
Gain	Gain < 3dBi
Impedance	50Ω
Input Power	>33 dBm (2W) peak power in GSM >24 dBm Average power in WCDMA
VSWR Absolute Max	≤ 10:1
VSWR Recommended	≤ 2:1

12.1.6 UMTS GPS Antenna Specifications:

12.1.6.1 Antenna Specifications

Parameter	Description
Input Voltage Range	3.0Vdc ±0.3Vdc
Frequency Range	1575.42± 2 MHz
Gain	=< 15dB overall at the connector (Antenna and LNA included)
Impedance	50 ohm
VSWR	≤ 1.5:1
Current Consumption	30mA (MAX), 20 mA TYP

12.1.7 Input / Output Lines

Input Lines (MIC + & MIC-)

Parameter	UMT864CF
Line Coupling	AC (*)
Line Type	Balanced
Coupling Capacitor	≥ 100 nF
Differential Input Impedance	20 k Ω
Differential Input Voltage	≤ 1290mVrms @ HSMicG=0dB
Volume Steps	7
Volume Level Step	6 dB/Step

**Warning: The line coupling definition "AC" means that the signals from the microphone must be connected to the input lines of the module through capacitors, not less than 100 nF. By not respecting this constraint, the input stage may be damaged.*

Output Lines (EAR+ & EAR-)

Parameter	UMT864CF
Line Coupling	DC
Output Load Impedance	≤ 26 Ω
Differential Output Impedance	≤ 01 @ 1.02 kHz
Signal Bandwidth	150-4000 Hz @ -3dB
Differential Output Voltage (max)	1.06 Vrms/32
Volume Steps	10
Volume Level Step	2 dB/Step

12 UMTS864CF TECHNICAL SPECIFICATIONS continued

12.1 Electrical Specification continued

12.1.8 USB Transceiver Specifications

Parameter	Comments	Min	Typ	Max	Unit
USB_VBUS					
Supply voltage		4.5	5.0	5.25	Volt
Supply current				25	mA
Input levels for low-/full speed					
Receiver threshold (single-end)		0.8	-	2.0	Volt
Differential input sensitivity	ID+ - D-I, Vin = 0.8V to 2.5V	0.2	-	-	Volt
Differential common-mode range	Includes VDI	0.8	-	2.5	Volt
Output levels for low-/full speed					
Low	RL = 1.5 kΩ to 3.6 V	-	-	0.3	Volt
High	RL – 15 kΩ to GND	2.8	-	3.6	Volt
Output signal crossover voltage		1.3	-	2.0	Volt
Terminations					
Internal pull-up resistor	VTRM to D+, VTRM to D-	1.425	1.5	1.575	kΩ
Internal pull-down resistor	D= to GND, D- to GND	14.3	15	24.8	kΩ
High-Z state output impedance	0 V < VDD < 3.6 V; measured at D+ and D- pins to GND	300	-	-	kΩ
Termination voltage	An internal supply voltage, VTRM	3.0	3.3	3.6	Volt
Driver characteristics – full speed					
Transition time:					
Rise time	CL = 50 to 125 pF	4	-	20	ns
Fall time	CL – 50 to 125 pF	4	-	20	ns
Rise/fall time matching		90	-	111	%
Series output resistance	D+, D-	28	33	44	Ω
Driver characteristics – low speed					
Transition time:					
Rise time	CL = 50 to 600 pF	75	-	300	ns
Fall time	CL – 50 to 600 F	75	-	30	ns
Rise/fall time matching		80	-	125	%
USB_ID (for future use only)					
ID pin pull-up resistance		108	140	182	kΩ
A-device detection threshold	t _{delay} < 1 μs, V _{phys} = 50 mV	-	0.15* VTRM	-	Volt
B-device detection threshold	t _{delay} < 1 μs, V _{phys} = 50 mV		0.8* VTRM	-	Volt

12 UMTS864CF TECHNICAL SPECIFICATIONS continued

12.2 Mechanical Specification

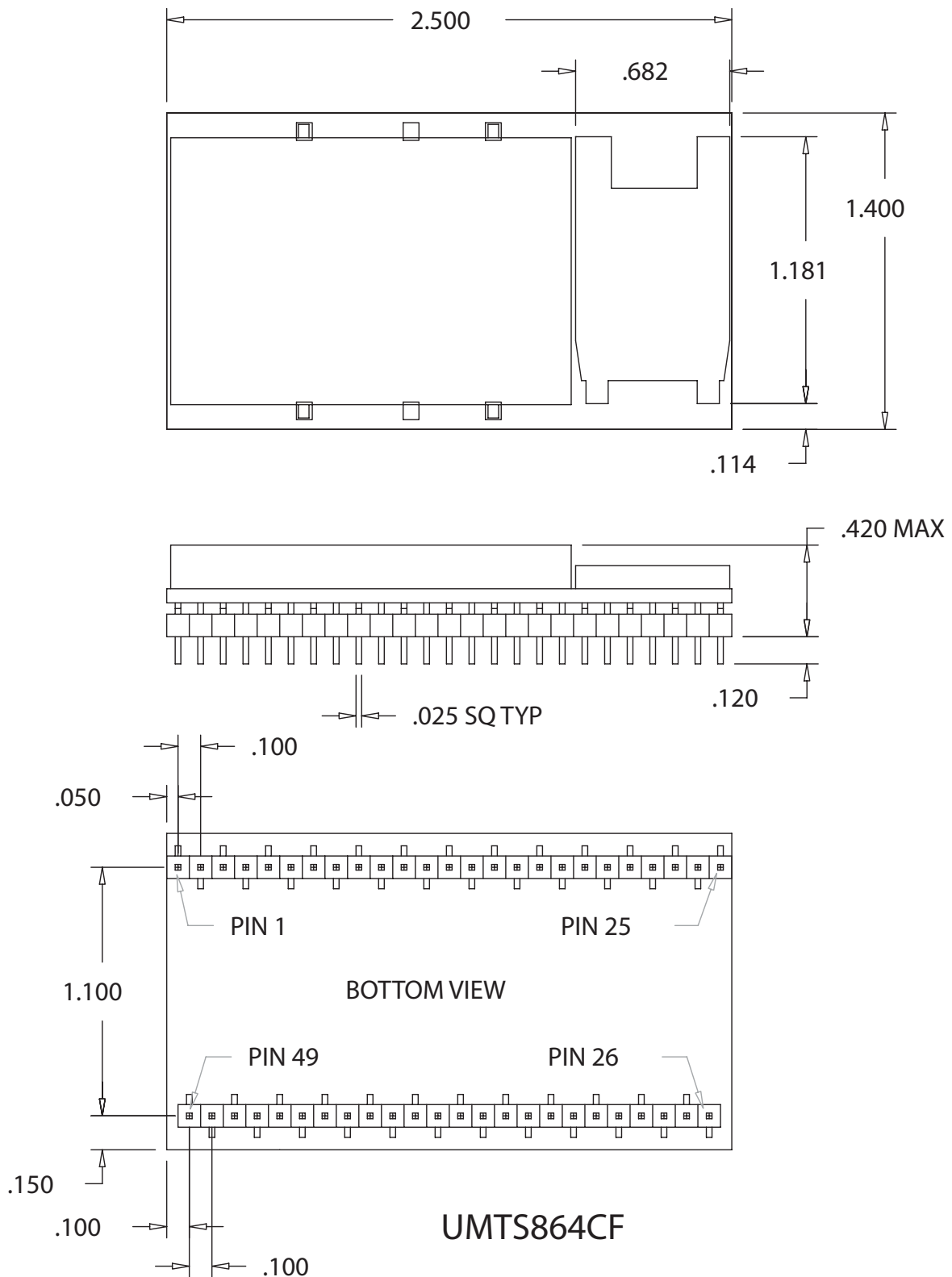

Figure 19 UMTS864CF Mechanical Dimensions

12 UMTS864CF TECHNICAL SPECIFICATIONS continued

12.3 Setting Up a Terminal Emulator for Use With the UMTS864CF Terminus

12.3.1 Set Up

To interface with the module, connect the serial interface to a PC and use a terminal emulation program such as Microsoft® Hyperterminal. Set the interface parameters as follows:

- Baud Rate: 115.2 kbps
- Bits: 8
- Stop Bits: 1
- Parity: None
- Hardware Handshaking: Yes

12.3.1.1 Test the Emulator Set Up

- Enter AT<cr> from terminal and wait for OK

Note that Autobaud is not supported on the UMTS864CF Terminus. If you are utilizing the serial interface and you wish to change the baud rate on the module, you must use AT+IPR. You must also change the rate in the host UART (i.e. HyperTerminal) to match the new baud rate. If these do not match you will not be able to send AT commands to the module through the serial port. The Terminus is by default set to 115.2 kbps.

12.3.1.2 Verify Your Terminal and Firmware Version

- Enter AT+CGMM and wait for the response
The response will be the Telit module's model number without a command echo.
- Enter AT+CGMR and wait for the response
The response will be the Telit module's current firmware without a command echo.

Please confirm your model and firmware with the one listed in section 2.1

12.3.2 Powering ON/OFF

12.3.2.1 Turn the module ON through the following method:

- Pull ON/OFF signal (Pin 19) to ground for two (2) seconds, then release.

The Terminus module is fully operational after 4 seconds. Logging onto a network may take longer than this and is outside the control of the Terminus.

12.3.2.2 There are two ways to switch OFF the module as described below.

- Use the appropriate AT command (AT#SHDN)
- Pull ON/OFF signal (Pin 19) to ground for two (2) seconds, then release.

12.3 UMTS864CF GETTING STARTED continued

12.3 Setting Up a Terminal Emulator for Use With the UMTS864CF Terminus continued

12.3.3 Setting Up Service – Network Settings

11.3.3.1 Set Up

The network settings for the Terminus will vary depending on the cellular carrier you are using. Below are two of the North American Cases for these settings.

For T-mobile® & MNVO (Raco®, Sensor Logic®, Nexaira® Jasper Wireless®) enter:

- AT#SELINT=2 //use of most recent AT command set
- AT#STIA=2,10 or AT#STIA=1 // enable SAT – SIM Application Tool-Kit
- AT#BND=3 // default bands to 850/1900
- AT#AUTOBND=1 // enable Quad band system selection
- AT#PLMNMODE=1 // enable EONS (enhanced operator naming scheme)
- AT&P0 // save profile
- AT&W0 // save setting
- AT#ENS=0

For AT&T/Cingular® & MNVO (Kore®, Aeris®, nPhase®) enter:

- AT#SELINT=2 //use of most recent AT command set
- AT#ENS=1 // AT&T/Cingular configuration (SAT, BND, AUTONBND, PLMNMODE, plus Cingular® specific ENS requirements)

If Terminus is being used in a different country or with a different carrier please refer to Telit AT command reference document regarding the use of the AT#BND command to set the proper frequency band).

Important: After entering either of the sets of settings above power the Terminus OFF and then ON. It is now ready for use.

12.3.3.2 Check Network Status (assuming you have a valid SIM card installed)

Enter AT+CREG? <cr> And wait for response.

Response will be +CREG:0,1 or +CREG: 0,5 meaning the device is registered to the home network or roaming, respectively. If response is different than this, please refer to the Telit AT command reference document for more information.

12.3.3.3 Check Signal Quality

Enter AT+CSQ<cr> And wait for response +CSQ:<rss>,<ber>

<rss>	Signal Strength
99	Not known or not detectable
0-31	dBm = (rss * 2) –113

Example: A result of 31 indicates -51dBm or greater.

An rssi value of >=10 in typical applications is fine and you will usually see about 12-20 in normal to good signal, but note that worst case it can be lower, still register and perform normal functions.

12.3.4 Making a Voice Call

12.3.4.1 Set Up

Voice call mode allows you to use a telephone handset to communicate with a properly equipped subscriber unit.

- Set the call mode to voice
Enter AT+FCLASS=8<cr> and wait for response OK
- Set the audio path of the Terminus
Enter AT#CAP=0
- Dial the phone number
Enter ATD <8885551234>; <cr>
- To disconnect the call enter ATH<cr>

Note that the current AT&T approval for the UMTS864CF does not allow voice calls.

12.3 UMTS864CF GETTING STARTED continued

12.3 Setting Up a Terminal Emulator for Use With the UMTS864CF Terminus continued

12.3.5 Sending an SMS

12.3.5.1 Set Up

SMS (Select Message Service) mode allows you to send a text message (max 160 characters) to a SMS capable subscriber unit.

- Set the SMS mode to text. This must be entered every power cycle.
AT+CMGF=1<cr>
- To enter the receiving subscriber unit phone number and message enter:
AT+CMGS="8885551234"
Wait for response">" then enter message text
Enter "ctrl z" <cr> to end the message

12.3.6 Making a GPRS Data Call

12.3.6.1 Set Up

GPRS is a data service that uses Packet Data Protocol (PDP).

- Set up the PDP context parameters
Enter AT+CGDCONT=1, "IP", "APN", "0.0.0.0",0,0<cr>
Where APN is specific to the service provider being used.
- Set the minimum Quality of Service profile
Enter AT+CGQMIN=1,0,0,0,0
- Set up the desired Quality of Service profile
Enter AT+CGQREQ=1,0,0,3,0,0
- Activate the PDP context
Enter AT#SGACT=1,1,"v", "p"
Where v is your user ID and p is your password.
If these are not set replace with "", ""
- Open the socket connection
Enter AT#SD=1,0,IPP,IPA,0,0,0
Look for response "CONNECT". This opens a remote connection via socket
IPP = the remote host port of the server you are trying to connect to (0 to 65535).
IPA = the IP address of the server you are trying to connect to in the format:
"xxx.xxx.xxx.xxx"
- At this point a data session is active and data can be sent from the Terminus to the remote device and visa versa.
- To exit the data session and return to command mode, send the characters"+++" and wait for the OK response
- Enter AT#SH=1 to close the socket

12.3 UMTS864CF GETTING STARTED continued

12.3 Setting Up a Terminal Emulator for Use With the UMTS864CF Terminus continued

12.3.7 GPS

The GPS data can be acquired over the AT Command port with the following methods.

General commands for both methods 1 and 2:

Define Antenna Type:

Send command AT\$GPSAT=1<cr>

Method 1:

Send command AT\$GPSP=1<cr>

Send command AT\$GPSACP<cr>

\$GPSACP can retrieve GPS data at any point when \$GPSP=1

Method 2:

Configure Unsolicited NMEA Data:

Send command to enable NMEA stream

AT\$GPSNMUN=<enable><gga><gll><gsa><gsv><rmc><vtg><cr>

Select parameter "1" to enable or "0" to disable for your NMEA stream requirements

EXAMPLE: AT\$GPSNMUN=1,1,1,1,1,1,1

Start NMEA Stream:

Send command AT\$GPSP=1<cr>

End NMEA Stream:

Send command AT\$GPSP=0<cr>

12.3.8 Further Instructions

On utilizing different commands for other applications than those described here, please refer to these reference documents, listed in section 2.1

- Telit UC864 AT Commands Reference Guide
- Telit UC864 Software User Guide

13 HSPA910CF TECHNICAL SPECIFICATIONS

13.1 Electrical Specification

13.1.1 Absolute Maximum Ratings

Parameter	Min	Typ	Max	Unit	Note
VIN (DIGITAL INPUTS 2.85V CMOS)	-0.5	-	3.35	Volt	
VIN (DIGITAL INPUTS 1.8V CMOS)	-0.3	-	3.1	Volt	
Storage Temperature	-40	-	85	°C	
Supply (+) referenced to Supply (-)	0	-	6	Volt	

Operation of the device at these or any other conditions beyond those listed under Recommended Operating Conditions is not implied. Exposure to Absolute Maximum Rating conditions for extended periods of time may affect device reliability.

13.1.2 Recommended Operating Conditions

Parameter	Min	Typ	Max	Unit	Note
Temperature	-30	-	80	°C	
Supply (+) referenced to Supply (-)	4.75	5.0	5.25	Volt	
VAUX Output	-	2.85	-	Volt	
VAUX Current	-	-	100	mA	

13.1.3 Power Supply

Mode	Average (mA)	Mode Description
POWERED DOWN		
Terminal Disabled	≤ 15µA	Terminal disabled (ENABLE SUPPLY = 0)
Cellular Radio Off	0.4	Cellular module powered but switched off via ON_OFF pin (PWRMON=0)
IDLE MODE		
Mode	Average (mA)	Mode Description
GPS OFF		
AT+CFUN=1	WCDMA 13.8 GSM 13.9	Idle, no call in progress. Full functionality of the module
AT+CFUN=4	WCDMA 14.4 GSM 14.4	Disabled TX and RX; module is not registered on the network
AT+CFUN=5	WCDMA 3.4 GSM 3.3	CFUN=5 full functionality with power saving; Module registered on the network can receive incoming call sand SMS
AT+CFUN=7	WCDMA 10.0 GSM 9.2	CFUN=5 full functionality with power saving; Module registered on the network can receive incoming call sand SMS
WCDMA/HSDPA		GPS OFF in HSPA910CF
WCDMA Voice	TBD	voice channel
WCDMA data	130.2	data channel
GSM		
GSM Voice	TBD	GSM voice channel
GPRS Class 12	129.3	GPRS data channel
GPS ON		
AT+CFUN=1	WCDMA 35.5 GSM 37.2	Idle, no call in progress. Full functionality of the module
AT+CFUN=4	WCDMA 36.8 GSM 37.6	Disabled TX and RX; module is not registered on the network
AT+CFUN=5	WCDMA 28.9 GSM 30.0	Disabled TX and RX; module is not registered on the network
AT+CFUN=7	WCDMA 33.8 GSM 34.3	Disabled TX and RX; module is not registered on the network
WCDMA/HSDPA		
WCDMA Voice	TBD	WCDMA voice channel
WCDMA Data	156	WCDMA data channel
GSM		
GSM Voice	TBD	GSM voice channel
GPRS/EDGE Class 12	152	GPRS data channel

* except external active GPS antenna.

* Data taken with USB disconnected.

13 HSPA910CF TECHNICAL SPECIFICATIONS continued

13.1 Electrical Specification continued

13.1.4 I/O Levels

13.1.4.1 1.8v Standard Interface Levels (DVI, I2C, GPS LED)

Parameter	Min	Typ	Max	Unit	Note
Input Voltage High - Vih	1.5	-	1.9	Volt	
Input Voltage Low - Vil	0	-	0.35	Volt	
Output Voltage High - Voh	1.6	-	1.9	Volt	
Output Voltage Low - Vol	0	-	0.2	Volt	

Typical Current Source/Sink = 100uA/1uA

13.1.4.2 2.85v Standard Interface Levels (UART, GPIO)

Parameter	Min	Typ	Max	Unit	Note
Input Voltage High - Vih	1.85	-	2.85	Volt	
Input Voltage Low - Vil	0	-	0.99	Volt	
Output Voltage High - Voh	2.45	-	2.85	Volt	
Output Voltage Low - Vol	0	-	0.4	Volt	

Typical Current Source = 100uA/1uA

13.1.4.3 Cellular LED Output Levels

Parameter	Min	Typ	Max	Unit	Note
Output Voltage High - Voh	1.6	-	1.9	Volt	
Output Voltage Low - Vol	0	-	0.2	Volt	

Typical Current Source = 100uA

13.1.4.4 ADC Input Levels

Parameter	Min	Typ	Max	Unit	Note
Input Voltage Range	0	-	1.2	Volt	
AD Conversion	-	-	10	Bits	
Input Resistance	1M	-	-	Ohm	
Input Capacitance	-	1	-	pF	

13.1.4.5 Reset Pin Input Levels

Parameter	Min	Typ	Max	Unit	Note
Input Voltage High - Vih	1.5	-	1.9	Volt	
Input Voltage Low - Vil	0	-	0.35	Volt	

It is required that this input be controlled by an Open Collector/Drain Output. Do not use an external pull-up resistor, a pull-up is included internal to the Terminus.

13 HSPA910CF TECHNICAL SPECIFICATIONS continued

13.1 Electrical Specification continued

13.1.5 HSPA+ Cellular Antenna Specifications:

13.1.5.1 Antenna Specifications

Parameter	Description
Frequency Range	Depending on frequency bands provided by the network operator, the customer should use the most suitable antenna for those frequencies.
Bandwidth	70MHz in GSM850 80 MHz in GSM900 170 MHz in DCS & 140 MHz PCS 70 MHz in WCDMA850 80 MHz in WCDMA900 460 MHz in WCDMA1700 140 MHz in WCDMA1900 250 MHz in WCDMA2100
Gain	Gain < 3dBi
Impedance	50Ω
Input Power	>33 dBm (2W) peak power in GSM >24 dBm Average power in WCDMA
VSWR Absolute Max	≤ 5:1
VSWR Recommended	≤ 2:1

13.1.6 HSPA910CF GPS Antenna Specifications:

13.1.6.1 Antenna Specifications

Parameter	Description
Input Voltage Range	2.85V
Frequency Range	1575.42± 2 MHz
Gain	=< 15dB overall at the connector (Antenna and LNA included).
Impedance	50 ohm
VSWR	TBD
Current Consumption	30mA Max, 20mA Typ.

13 HSPA910CF TECHNICAL SPECIFICATIONS continued

13.1 Electrical Specification continued

13.1.7 USB Transceiver Specifications

Parameter	Comments	Min	Typ	Max	Unit
USB_VBUS					
Supply voltage		4.5	5.0	5.25	Volt
Supply current				25	mA
Input levels for low-/full speed					
Receiver threshold (single-end)		0.8	-	2.0	Volt
Differential input sensitivity	ID+ - D-I, Vin = 0.8V to 2.5V	0.2	-	-	Volt
Differential common-mode range	Includes VDI	0.8	-	2.5	Volt
Output levels for low-/full speed					
Low	RL = 1.5 kΩ to 3.6 V	-	-	0.3	Volt
High	RL – 15 kΩ to GND	2.8	-	3.6	Volt
Output signal crossover voltage		1.3	-	2.0	Volt
Terminations					
Internal pull-up resistor	VTRM to D+, VTRM to D-	1.425	1.5	1.575	kΩ
Internal pull-down resistor	D= to GND, D- to GND	14.3	15	24.8	kΩ
High-Z state output impedance	0 V < VDD < 3.6 V; measured at D+ and D- pins to GND	300	-	-	kΩ
Termination voltage	An internal supply voltage, VTRM	3.0	3.3	3.6	Volt
Driver characteristics – full speed					
Transition time:					
Rise time	CL = 50 to 125 pF	4	-	20	ns
Fall time	CL – 50 to 125 pF	4	-	20	ns
Rise/fall time matching		90	-	111	%
Series output resistance	D+, D-	28	33	44	Ω
Driver characteristics – low speed					
Transition time:					
Rise time	CL = 50 to 600 pF	75	-	300	ns
Fall time	CL – 50 to 600 F	75	-	30	ns
Rise/fall time matching		80	-	125	%

13 HSPA910CF TECHNICAL SPECIFICATIONS continued

13.2 Mechanical Specification

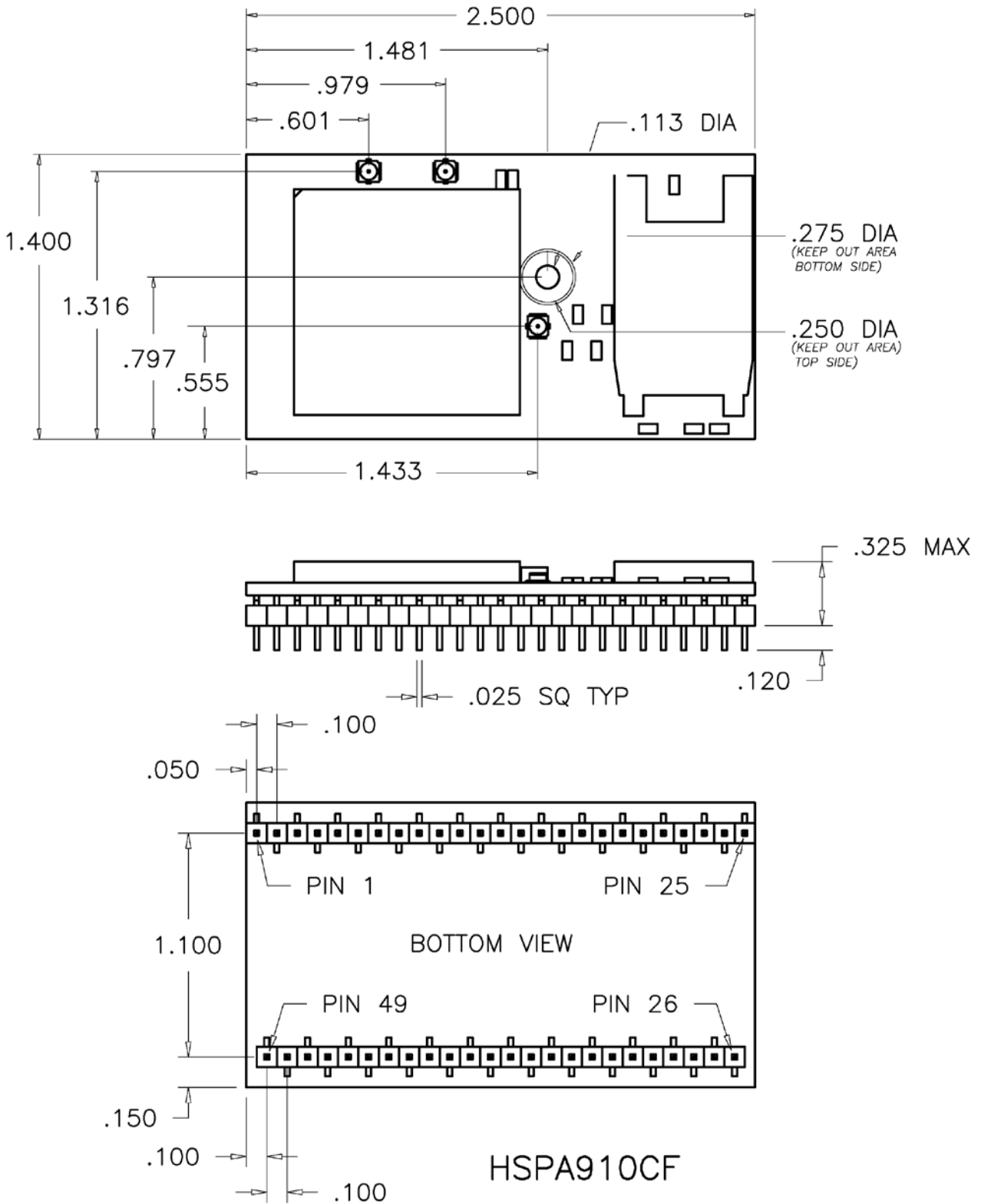

Figure 20 HSPA910CF Mechanical Dimensions

13 HSPA910CF TECHNICAL SPECIFICATIONS continued

13.3 Setting Up a Terminal Emulator for Use With the HSPA910CF Terminus

13.3.1 Set Up

To interface with the module, connect the serial interface to a PC and use a terminal emulation program such as Microsoft® Hyperterminal. Set the interface parameters as follows:

- Baud Rate: 115.2 kbps
- Bits: 8
- Stop Bits: 1
- Parity: None
- Hardware Handshaking: Yes

13.3.1.1 Test the Emulator Set Up

- Enter AT<cr> from terminal and wait for OK

Note that Autobaud is not supported on the HSPA910CF Terminus. If you are utilizing the serial interface and you wish to change the baud rate on the module, you must use AT+IPR. You must also change the rate in the host UART (i.e. HyperTerminal) to match the new baud rate. If these do not match you will not be able to send AT commands to the module through the serial port. The Terminus is by default set to 115.2 kbps.

13.3.1.2 Verify Your Terminal and Firmware Version

- Enter AT+CGMM and wait for the response
The response will be the Telit module's model number without a command echo.
- Enter AT+CGMR and wait for the response
The response will be the Telit module's current firmware without a command echo.

Please confirm your model and firmware with the one listed in section 2.1

13.3.2 Powering ON/OFF

13.3.2.1 Turn the module ON through the following method:

- Pull ON/OFF signal (Pin 19) to ground for three (3) seconds, then release.

The Terminus module is fully operational after 4 seconds. Logging onto a network may take longer than this and is outside the control of the Terminus.

13.3.2.2 There are two ways to switch OFF the module as described below.

- Use the appropriate AT command (AT#SHDN)
- Pull ON/OFF signal (Pin 19) to ground for three (3) seconds, then release.

13.3 HSPA910CF GETTING STARTED continued

13.3 Setting Up a Terminal Emulator for Use With the HSPA910CF Terminus continued

13.3.3 Setting Up Service – Network Settings

13.3.3.1 Set Up

The network settings for the Terminus will vary depending on the cellular carrier you are using. Below are two of the North American Cases for these settings.

For T-mobile® & MNVO (Raco®, Sensor Logic®, Nexaira® Jasper Wireless®) enter:

- AT#SELINT=2 //use of most recent AT command set
- AT#STIA=2,10 or AT#STIA=1 // enable SAT – SIM Application Tool-Kit
- AT#BND=3,3 // default bands to 850/1900/2100
- AT#AUTOBND=1 // enable Quad band system selection
- AT&P0 // save profile
- AT&W0 // save setting
- AT#ENS=0

For AT&T/Cingular® & MNVO (Kore®, Aeris®, nPhase®) enter:

- AT#SELINT=2 //use of most recent AT command set
- AT#ENS=1 // AT&T/Cingular configuration (SAT, BND, AUTONBND, PLMNMODE, plus Cingular® specific ENS requirements)

If Terminus is being used in a different country or with a different carrier please refer to Telit AT command reference document regarding the use of the AT#BND command to set the proper frequency band).

Important: After entering either of the sets of settings above power the Terminus OFF and then ON. It is now ready for use.

13.3.3.2 Check Network Status (assuming you have a valid SIM card installed)

Enter AT+CREG? <cr> And wait for response.

Response will be +CREG:0,1 or +CREG: 0,5 meaning the device is registered to the home network or roaming, respectively. If response is different than this, please refer to the Telit AT command reference document for more information.

13.3.3.3 Check Signal Quality

Enter AT+CSQ<cr> And wait for response +CSQ:<rss>,<ber>

<rss> Signal Strength
99 Not known or not detectable
0-31 dBm = (rss * 2) –113

Example: A result of 31 indicates -51dBm or greater.

An rssi value of >=10 in typical applications is fine and you will usually see about 12-20 in normal to good signal, but note that worst case it can be lower, still register and perform normal functions.

13.3.4 Making a Voice Call

13.3.4.1 Set Up

Voice call mode allows you to use a telephone handset to communicate with a properly equipped subscriber unit.

- Set the call mode to voice
Enter AT+FCLASS=8<cr> and wait for response OK
- Dial the phone number
Enter ATD <8885551234>; <cr>
- To disconnect the call enter ATH<cr>

13.3 HSPA910CF GETTING STARTED continued

13.3 Setting Up a Terminal Emulator for Use With the HSPA910CF Terminus continued

13.3.5 Sending an SMS

13.3.5.1 Set Up

SMS (Select Message Service) mode allows you to send a text message (max 160 characters) to a SMS capable subscriber unit.

- Set the SMS mode to text. This must be entered every power cycle.
AT+CMGF=1<cr>
- To enter the receiving subscriber unit phone number and message enter:
AT+CMGS="8885551234"
Wait for response">" then enter message text
Enter "ctrl z" <cr> to end the message

13.3.6 Making a GPRS Data Call

13.3.6.1 Set Up

GPRS is a data service that uses Packet Data Protocol (PDP).

- Set up the PDP context parameters
Enter AT+CGDCONT=1, "IP", "APN", "0.0.0.0",0,0<cr>
Where APN is specific to the service provider being used.
- Activate the PDP context
Enter AT#SGACT=1,1,"v", "p"
Where v is your user ID and p is your password.
If these are not set replace with "", ""
- Open the socket connection
Enter AT#SD=1,0,IPP,IPA,0,0,0
Look for response "CONNECT". This opens a remote connection via socket
IPP = the remote host port of the server you are trying to connect to. (0 to 65535)
IPA = the IP address of the server you are trying to connect to in the format:
"xxx.xxx.xxx.xxx"
- At this point a data session is active and data can be sent from the Terminus to the remote device and visa versa.
- To exit the data session and return to command mode, send the characters"+++" and wait for the OK response
- Enter AT#SH=1 to close the socket

13.3 HSPA910CF GETTING STARTED continued

13.3 Setting Up a Terminal Emulator for Use With the HSPA910CF Terminus continued

13.3.7 GPS

The GPS data can be acquired over the AT Command port with the following methods.

Method 1:

Send command `AT$GPSP=1<cr>`
Send command `AT$GPSACP<cr>`
`$GPSACP` can retrieve GPS data at any point when `$GPSP=1`

Method 2:

Configure Unsolicited NMEA Data:
Send command to enable NMEA stream
`AT$GPSNMUN=<enable><gga><gll><gsa><gsv><rmc><vtg><cr>`
Select parameter "1" to enable or "0" to disable for your NMEA stream requirements

EXAMPLE: `AT$GPSNMUN=1,1,1,1,1,1,1`
Send command `AT$GPSP=1<cr>`
End NMEA Stream:
Send command `AT$GPSP=0<cr>`

13.3.8 Further Instructions

On utilizing different commands for other applications than those described here, please refer to these reference documents, listed in section 2.1

- Telit HE910 AT Commands Reference Guide
- Telit HE910 Software User Guide

14 EVDO910CF TECHNICAL SPECIFICATIONS

14.1 Electrical Specification

14.1.1 Absolute Maximum Ratings

Parameter	Min	Typ	Max	Unit	Note
VIN (DIGITAL INPUTS 2.85V CMOS)	-0.5	-	3.35	Volt	
VIN (DIGITAL INPUTS 1.8V CMOS)	-0.3	-	3.1	Volt	
Storage Temperature	-40	-	85	°C	
Supply (+) referenced to Supply (-)	0	-	6	Volt	

Operation of the device at these or any other conditions beyond those listed under Recommended Operating Conditions is not implied. Exposure to Absolute Maximum Rating conditions for extended periods of time may affect device reliability.

14.1.2 Recommended Operating Conditions

Parameter	Min	Typ	Max	Unit	Note
Temperature	-30	-	80	°C	
Supply (+) referenced to Supply (-)	4.75	5.0	5.25	Volt	
VAUX Output	-	2.85	-	Volt	
VAUX Current	-	-	100	mA	

14.1.3 Power Supply

Mode	Average (mA)	Mode Description
POWERED DOWN		
Terminal Disabled	≤ 15µA	Terminal disabled (ENABLE SUPPLY = 0)
Cellular Radio Off	0.4	Cellular module powered but switched off via ON_OFF pin (PWRMON=0)
IDLE MODE		
Mode	Average (mA)	Mode Description
GPS OFF		
AT+CFUN=1	13	Idle, no call in progress. Full functionality of the module
AT+CFUN=4	20	Disabled TX and RX; module is not registered on the network
AT+CFUN=5	3	CFUN=5 full functionality with power saving; Module registered on the network can receive incoming call sand SMS
AT+CFUN=7	TBD	CFUN=5 full functionality with power saving; Module registered on the network can receive incoming call sand SMS
EV-DO		
Voice	TBD	Voice channel
Data	570	Data channel
CDMA		
Voice	TBD	Voice channel
Data	590	Data channel
GPS ON		
AT+CFUN=1	60	Idle, no call in progress. Full functionality of the module
AT+CFUN=4	75	Disabled TX and RX; module is not registered on the network
AT+CFUN=5	57	Disabled TX and RX; module is not registered on the network
AT+CFUN=7	TBD	Disabled TX and RX; module is not registered on the network
EV-DO		
Voice	TBD	Voice channel
Data	640	Data channel
CDMA		
Voice	TBD	Voice channel
Data	640	Data channel

* except external active GPS antenna.

* Data taken with USB disconnected.

14 EVDO910CF TECHNICAL SPECIFICATIONS continued

14.1 Electrical Specification continued

14.1.4 I/O Levels

14.1.4.1 1.8v Standard Interface Levels (DVI, I2C, GPS LED)

Parameter	Min	Typ	Max	Unit	Note
Input Voltage High - Vih	1.5	-	1.9	Volt	
Input Voltage Low - Vil	0	-	0.35	Volt	
Output Voltage High - Voh	1.6	-	1.9	Volt	
Output Voltage Low - Vol	0	-	0.2	Volt	

Typical Current Source/Sink = 100uA/1uA

14.1.4.2 2.85v Standard Interface Levels (UART, GPIO)

Parameter	Min	Typ	Max	Unit	Note
Input Voltage High - Vih	1.85	-	2.85	Volt	
Input Voltage Low - Vil	0	-	0.99	Volt	
Output Voltage High - Voh	2.45	-	2.85	Volt	
Output Voltage Low - Vol	0	-	0.4	Volt	

Typical Current Source = 100uA/1uA

14.1.4.3 Cellular LED Output Levels

Parameter	Min	Typ	Max	Unit	Note
Output Voltage High - Voh	1.6	-	1.9	Volt	
Output Voltage Low - Vol	0	-	0.2	Volt	

Typical Current Source = 100uA

14.1.4.4 ADC Input Levels

Parameter	Min	Typ	Max	Unit	Note
Input Voltage Range	0	-	1.2	Volt	
AD Conversion	-	-	10	Bits	
Input Resistance	1M	-	-	Ohm	
Input Capacitance	-	1	-	pF	

14.1.4.5 Reset Pin Input Levels

Parameter	Min	Typ	Max	Unit	Note
Input Voltage High - Vih	1.5	-	1.9	Volt	
Input Voltage Low - Vil	0	-	0.35	Volt	

It is required that this input be controlled by an Open Collector/Drain Output. Do not use an external pull-up resistor, a pull-up is included internal to the Terminus.

14 EVDO910CF TECHNICAL SPECIFICATIONS continued

14.1 Electrical Specification continued

14.1.5 EV-DO Cellular Antenna Specifications:

14.1.5.1 Antenna Specifications

Parameter	Description
Frequency Range	Depending on frequency bands provided by the network operator, the customer should use the most suitable antenna for those frequencies.
Bandwidth	70MHz in CDMA BC0 140 MHz in CDMA BC1
Gain	Gain < 5dBi
Impedance	50Ω
Input Power	> 24.4 dBm in CDMA
VSWR Absolute Max	≤ 5:1
VSWR Recommended	≤ 2:1

14.1.6 EVDO910CF GPS Antenna Specifications:

12.1.6.1 Antenna Specifications

Parameter	Description
Input Voltage Range	2.85V
Frequency Range	1575.42± 2 MHz
Gain	=< 17dB at the connector
Impedance	50 ohm
VSWR	TBD
Current Consumption	30mA Max, 20mA Typ.

14.1.7 USB Transceiver Specifications

Parameter	Comments	Min	Typ	Max	Unit
USB_VBUS					
Supply voltage		4.5	5.0	5.25	Volt
Supply current				25	mA
Input levels for low-/full speed					
Receiver threshold (single-end)		0.8	-	2.0	Volt
Differential input sensitivity	ID+ - D-I, Vin = 0.8V to 2.5V	0.2	-	-	Volt
Differential common-mode range	Includes VDI	0.8	-	2.5	Volt
Output levels for low-/full speed					
Low	RL = 1.5 kΩ to 3.6 V	-	-	0.3	Volt
High	RL – 15 kΩ to GND	2.8	-	3.6	Volt
Output signal crossover voltage		1.3	-	2.0	Volt
Terminations					
Internal pull-up resistor	VTRM to D+, VTRM to D-	1.425	1.5	1.575	kΩ
Internal pull-down resistor	D= to GND, D- to GND	14.3	15	24.8	kΩ
High-Z state output impedance	0 V < VDD < 3.6 V; measured at D+ and D- pins to GND	300	-	-	kΩ
Termination voltage	An internal supply voltage, VTRM	3.0	3.3	3.6	Volt
Driver characteristics – full speed					
Transition time:					
Rise time	CL = 50 to 125 pF	4	-	20	ns
Fall time	CL – 50 to 125 pF	4	-	20	ns
Rise/fall time matching		90	-	111	%
Series output resistance	D+, D-	28	33	44	Ω
Driver characteristics – low speed					
Transition time:					
Rise time	CL = 50 to 600 pF	75	-	300	ns
Fall time	CL – 50 to 600 F	75	-	30	ns
Rise/fall time matching		80	-	125	%

14 EVDO910CF TECHNICAL SPECIFICATIONS continued

14.2 Mechanical Specification

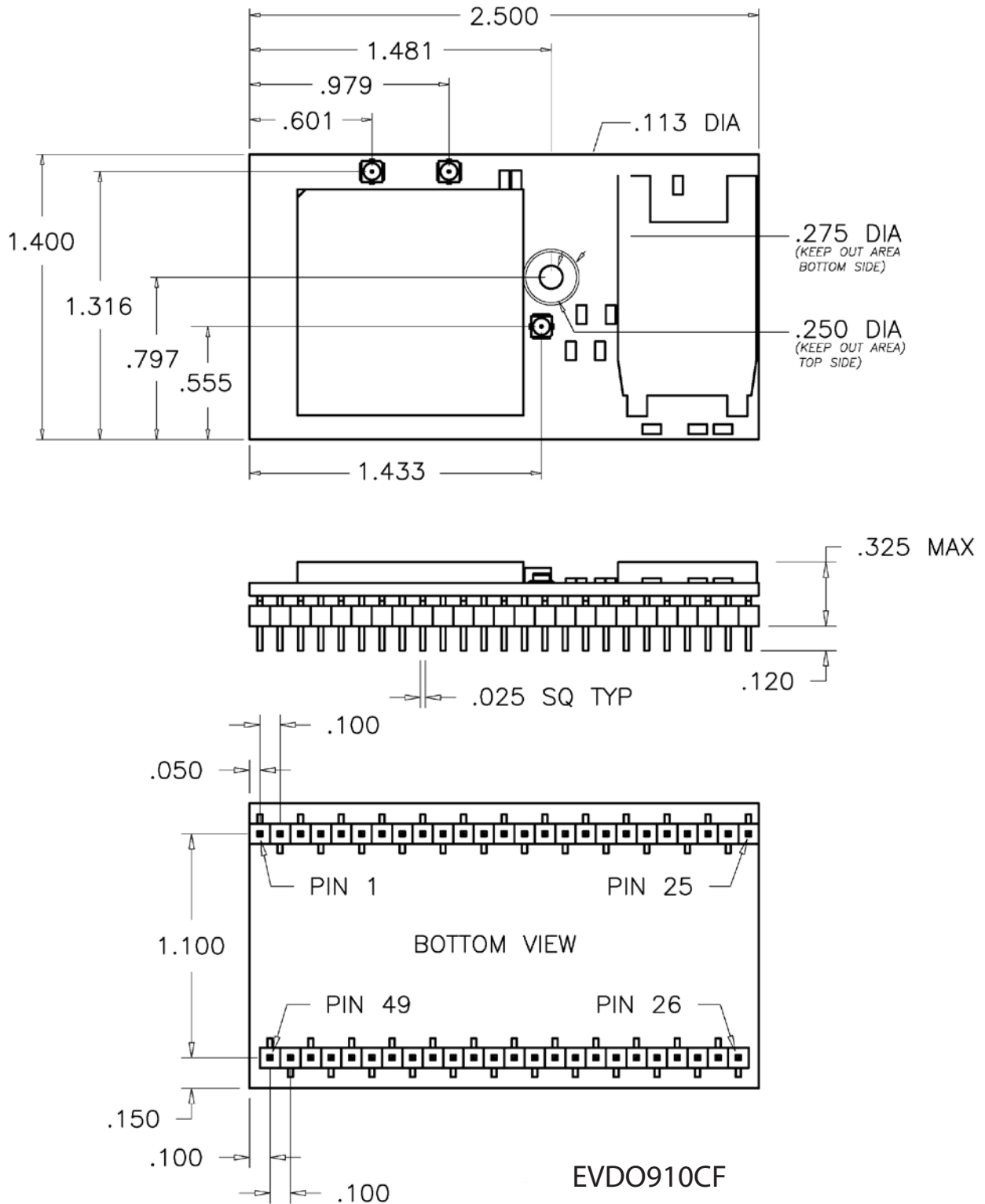

Figure 21 EVDO910CF Mechanical Dimensions

14 EVDO910CF TECHNICAL SPECIFICATIONS continued

14.3 Setting Up a Terminal Emulator for Use With the EVDO910CF Terminus

14.3.1 Set Up

To interface with the module, connect the serial interface to a PC and use a terminal emulation program such as Microsoft® Hyperterminal. Set the interface parameters as follows:

- Baud Rate: 115.2 kbps
- Bits: 8
- Stop Bits: 1
- Parity: None
- Hardware Handshaking: Yes

14.3.1.1 Test the Emulator Set Up

- Enter AT<cr> from terminal and wait for OK

Note that Autobaud is not supported on the EVDO910CF Terminus. If you are utilizing the serial interface and you wish to change the baud rate on the module, you must use AT+IPR. You must also change the rate in the host UART (i.e. HyperTerminal) to match the new baud rate. If these do not match you will not be able to send AT commands to the module through the serial port. The Terminus is by default set to 115.2 kbps.

14.3.1.2 Verify Your Terminal and Firmware Version

- Enter AT+CGMM and wait for the response
The response will be the Telit module's model number without a command echo.
- Enter AT+CGMR and wait for the response
The response will be the Telit module's current firmware without a command echo.

Please confirm your model and firmware with the one listed in section 2.1

14.3.2 Powering ON/OFF

14.3.2.1 Turn the module ON through the following method:

- Pull ON/OFF signal (Pin 19) to ground for three (3) seconds, then release.

The Terminus module is fully operational after 4 seconds. Logging onto a network may take longer than this and is outside the control of the Terminus.

14.3.2.2 There are two ways to switch OFF the module as described below.

- Use the appropriate AT command (AT#SHDN)
- Pull ON/OFF signal (Pin 19) to ground for three (3) seconds, then release.

14.3 EVDO910CF GETTING STARTED continued

14.3 Setting Up a Terminal Emulator for Use With the EVDO910CF Terminus continued

14.3.3 Setting Up Service

14.3.3.1 Provisioning the Plug-In Terminus

To provision the unit, you will need to contact Sprint, Verizon, Aeris, or an MVNO to set up a service contract.

Please see Janus Application Note Note 111: Provisioning Guide for Terminus M2M Devices

Contact: Dave Jahr, Janus Remote Communications
djahr@janus-rc.com
630-499-2121

14.3.4 Making a Voice Call

14.3.4.1 Set Up

Voice call mode allows you to use a telephone handset to communicate with a properly equipped subscriber unit.

- Set the call mode to voice
Enter AT+FCLASS=8<cr> and wait for response OK
- Dial the phone number
Enter ATD <8885551234>; <cr>
- To disconnect the call enter ATH<cr>

14.3.5 Sending an SMS

14.3.5.1 Set Up

SMS (Select Message Service) mode allows you to send a text message (max 160 characters) to a SMS capable subscriber unit.

- Set the SMS mode to text. This must be entered every power cycle.
AT+CMGF=1<cr>
- To enter the receiving subscriber unit phone number and message enter:
AT+CMGS="8885551234"
Wait for response">" then enter message text
Enter "ctrl z" <cr> to end the message

14.3 EVDO910CF GETTING STARTED continued

14.3 Setting Up a Terminal Emulator for Use With the EVDO910CF Terminus continued

14.3.6 Making a GPRS Data Call

14.3.6.1 Set Up

GPRS is a data service that uses Packet Data Protocol (PDP).

- Set up the PDP context parameters
Enter `AT+CGDCONT=1,"IP","APN","0.0.0.0",0,0<cr>`
Where APN is specific to the service provider being used.
- Activate the PDP context
Enter `AT#SGACT=1,1,"v","p"`
Where v is your user ID and p is your password.
If these are not set replace with ""
- Open the socket connection
Enter `AT#SD=1,0,IPP,IPA,0,0,0`
Look for response "CONNECT". This opens a remote connection via socket
IPP = the remote host port of the server you are trying to connect to. (0 to 65535)
IPA = the IP address of the server you are trying to connect to in the format:
"xxx.xxx.xxx.xxx"
- At this point a data session is active and data can be sent from the Terminus to the remote device and visa versa.
- To exit the data session and return to command mode, send the characters "+++" and wait for the OK response
- Enter `AT#SH=1` to close the socket

14.3.7 GPS

The GPS data can be acquired over the AT Command port with the following methods.

Method 1:

Send command `AT$GPSP=1<cr>`
Send command `AT$GPSACP<cr>`
`$GPSACP` can retrieve GPS data at any point when `$GPSP=1`

Method 2:

Enable the GPS:
Send command `AT$GPSP=<c>`

Configure Unsolicited NMEA Data:
Send command to enable NMEA stream
`AT$GPSNMUN=<enable><gga><gll><gsa><gsv><rmc><vtg><cr>`

Select parameter "1" to enable or "0" to disable for your NMEA stream requirements

EXAMPLE: `AT$GPSNMUN=3,1,1,1,1,1,1`

Note that for the EVDO910CF, enable MUST be 3 if using the UART. The UART will then become a dedicated NMEA stream, in order to stop the stream '+++' must be entered which will return the port to command mode.

End NMEA Stream:
Send command '+++'

Disable the GPS::
Send command `AT$GPSP=0<cr>`

14.3.8 Further Instructions

On utilizing different commands for other applications than those described here, please refer to these reference documents, listed in section 2.1

- Telit DE910 AT Commands Reference Guide
- Telit DE910 Software User Guide

Please see Janus Application Note Note 111: Provisioning Guide for Terminus M2M Devices

15 DESIGN CONSIDERATIONS

15.1 GSM, CDMA, UMTS & HSPA+ Minimum Required Module Pin Connects

GSM Pin Functions

Pin	Signal	Function	Note
1	VBATT	Main power supply	
2	VBATT	Main power supply	
12	GND	Ground	
25	GND	Ground	
26	GND	Ground	
39	GND	Ground	
49	GND	Ground	
19	ON/OFF	Input command for switching power ON or OFF (toggle command)	
9	TXD	Serial data input (TXD) from DTE	
20	RESET	Reset input	
4	RXD	Serial data output to DTE	
11	RTS	Input for request to send signal (RTS) from DTE	2
13	TXD_AUX		
14	RXD_AUX		
17	SERVICE		

CDMA, UMTS, HSPA+, and EV-DO Pin Functions

Pin	Signal	Function	Note
1	VBATT	Main power supply	
2	VBATT	Main power supply	
12	GND	Ground	
25	GND	Ground	
26	GND	Ground	
39	GND	Ground	
49	GND	Ground	
9	TXD	Serial data input (TXD) from DTE	
4	RXD	Serial data output to DTE	
11	RTS	Input for request to send signal (RTS) from DTE	2
19	ON/OFF	Input command for switching power ON or OFF (toggle command)	
20	RESET	Reset input	

Note:

1. If the application uses USB as the main interface to the module, this is sufficient to capture any debug or trace data, provided the application can export the diagnostic port externally.
2. RTS must be connected to ground if flow control is not used.
3. USB interface required for local firmware upgrade of Telit radio.

15.2 Debug:

Debug of the GSM865CF, CDMA864CF, UMTS864CF, HSPA910CF and EVDO910CF in production

To test and debug the mounting of the module, we strongly recommend test pads on the host PCB. This will allow verification of the connection between the module itself and the application and to test the performance of the module connecting it with an external computer.

Depending on the customer application, these pads include, but are not limited to the following signals:

- TXD
- RXD
- ON/OFF
- RESET
- GND
- VBATT
- TX_TRACE
- RX_TRACE
- PWRMON
- USB D+
- USB D-
- USB V_BUS
- USB_ID

APPENDICES

Approvals

AT&T Certification – GSM865CF (4/11)
PTCRB Certification – GSM865CF (2/11)
Sprint - CDMA864CF (7/10)
FCC Certified
CE Certified

Safety Recommendations (for Information only)

Antenna Care and Replacement

Do not use the Terminus with a damaged antenna.

Buy the antenna from an approved suppliers list. Using unauthorized antennas, modifications, or attachments could damage the Terminus and may violate local RF emission regulations or invalidate type approval.

Abbreviations

3GPP	3rd Generation Partnership Project	ITAR	International Traffic In Arm Regulation
AC	Alternating Current	LED	Light Emitting Diode
ADC	Analog To Digital Converter	M2M	Machine To Machine
BER	Bit Error Rate	PBCCH	Packet Broadcast Control Channel
CD	Carrier Detect	PDU	Protocol Data Unit
CDMA	Code Division Multiple Access	RF	Radio Frequency
CSD	Circuit Switched Data	RI	Ring Indicator
CTS	Clear To Send	RSSI	Received Signal Strength Indication
DB	Decibel	RTS	Request To Send
DBFS	Decibels Full Scale	RxD	Received Data
DC	Direct Current	SMS	Short Message Service
DCE	Data Communications Equipment	TTFF	Time To First Fix
DSR	Data Set Ready	TxD	Transmitted Data
DTMF	Dual-tone multi-frequency	UICC	Universal Integrated Circuit Card
DTR	DTE Ready	UMTS	Universal Mobile Telecommunications System
FDN	Fixed Dialing Number	USIM	Universal Subscriber Identity Module
GPIO	General Purpose Input Output	USSD	Unstructured Supplementary Service Data
GPRS	General Packet Radio Service	VSWR	Voltage Standing Wave Ratio
GSM	Global System Mobile	WAAS	Wide Area Augmentation System

Terminus Plug-In Products User Manual



Ordering Information

Ordering Information	Description
GSM865CF v1.1	Terminus GSM Plug-In Module - GPS enabled
GSM865CF v2.00	Terminus GSM Plug-In Module - without GPS
CDMA864CF v2.00	Terminus CDMA Plug-In Module - Sprint Certified
CDMA864CF v3.00	Terminus CDMA Plug-In Module - Verizon Certified
UMTS864CF v1.00	Terminus UMTS Plug-In Module
HSPA910CF v1.00	Terminus HSPA+ Plug-In Modem - GPS Enabled
EVDO910CF v1.00	Terminus EV-DO Plug-In Modem

Revision History

Revision	Revision Date	Note
A00	12/10/09	Advanced Plug-In User Manual
A01	03/31/10	Interfaces Power Supply Update
A02	05/24/10	I/O Level Specifications Chart Updates
P00	05/27/10	Release for publication
P01	03/17/11	Part Number Change, Getting Started Sec, Antenna Info
P02	05/02/11	GSM865CF Version Updated; V1.1
P03	05/26/11	Updated Getting Started Sections
P04	08/30/11	Addition of 8.6.9 Section and new GSM865CF Block Diagram
P05	09/15/11	Update to Section 10.1.3 Power Supply
P06	09/30/11	Update to Section 11.1.1 Absolute maximum Ratings
P07	10/05/11	Revisions to Section 10.3 Getting Started
P08	12/09/11	Revisions to Section 8 Interfaces and 11.3.1 Set-up
P09	01/17/12	General Revisions and New Section 12 - HSPA910CF
P10	02/23/12	Drawings HSPA910CF 12.2 and Screw Mounting diagram; information for section 8.12; Revisions to sections 7.1/ 8.1.2 / 8.2 / 8.4/ 8.6/ 8.9
P11	04/12/12	Certifications Updated for FCC and CE
P12	05/17/12	HSPA910CF Power Specs Revisions
P13	08/16/12	Additional HSPA910CF Spec Revisions
P14	11/15/12	Additional EVDO910CF Spec Revisions
P15	03/18/13	Equations added to 9.5 and Section added to 9.6 - Enable Pin
P16	04/23/13	HSPA+ Sensitivity Updates and Provisioning Updates



Division of The Connor-Winfield Corporation
2111 Comprehensive Drive • Aurora, Illinois 60505
630.499.2121 • Fax: 630.851.5040

www.janus-rc.com

Janus Remote Communications Europe

Bay 143
Shannon Industrial Estate
Shannon, Co. Clare, Ireland
Phone: +353 61 475 666