

***/ Marley 1500 Series Bearing Assembly /***

---

***User Manual 98-1383A***

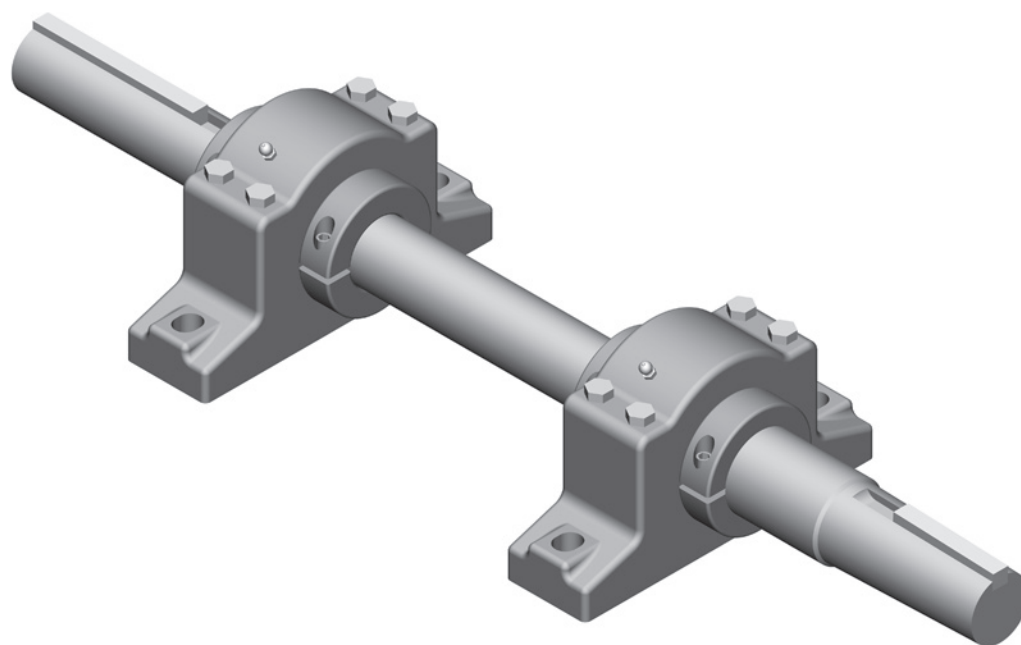

## Components

---

- 1 Shaft
- 2 Fan Key
- 3 Sheave key
- 4 Bearing (2 required)

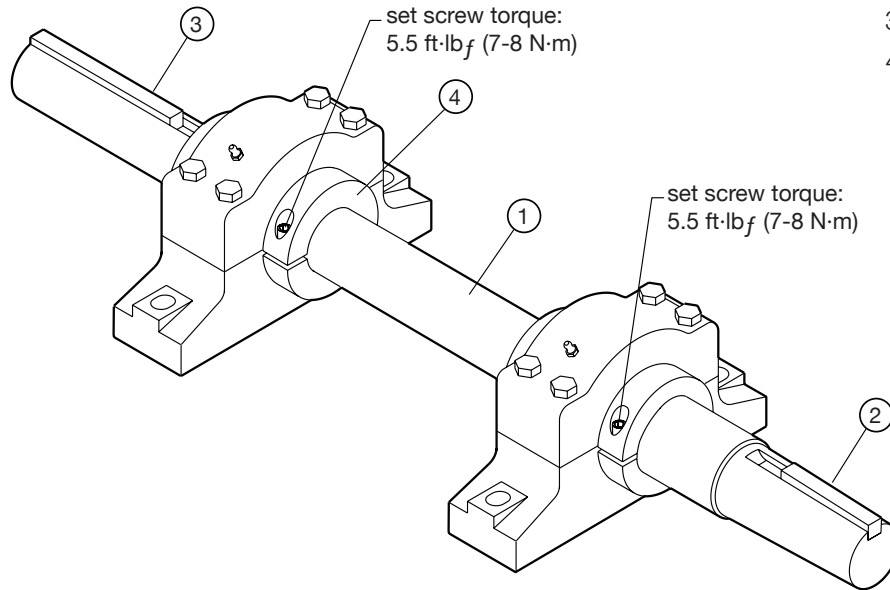

**Installation:** Installation should only be performed by a qualified technician. Lockout and disable any system drivers. Coat the shaft(s) with a lubricant or anti-seize compound. Follow the instructions supplied with your replacement kit or the tower User Manual. Contact your Marley sales representative should you need more information for your application.

**Maintenance:** Lubricate the bearings with Chevron SRI-2 grease. Grease initially and subsequently every 3 to 6 months. Consult your Marley sales representative for alternate lubricants.

**Bearing Replacement:** Bearings should only be replaced by a qualified technician. Replace a bearing by removing its mounting bolts and loosening the bearing locking collar set screws. Slide the bearing off the shaft and install the new bearing oriented the same as the bearing removed. Tighten the bearing mounting bolts. Fit the new bearing locking collars square and snug against the bearing shoulder. Tighten the locking collar set screws as specified.

**SPX**<sup>®</sup>

COOLING TECHNOLOGIES

7401 WEST 129 STREET | OVERLAND PARK, KANSAS 66213 UNITED STATES | 913 664 7400 | [spxcooling@spx.com](mailto:spxcooling@spx.com) | [spxcooling.com](http://spxcooling.com)

In the interest of technological progress, all products are subject to design and/or material change without notice.  
©2010 SPX Cooling Technologies, Inc. | Printed in USA

Manual 98-1383A