



Self-Weighing Truck and Trailer Scales™



QuickLoad On-Board Scale

Installation Guide

for Trucks and Tractors

PN: 901-0123-000 R6

TABLE OF CONTENTS

I. SCALE OVERVIEW.....	4
1. QuickLoad Tractor Scale Overview.....	5
2. Installation Overview for QuickLoad Scale System	7
A. Overview for Electronic Components Installation	7
B. Overview for Air Pressure Sensor(s) Installation	7
C. Overview for Deflection Sensor(s) Installation	8
II. QUICKLOAD PARTS PER VEHICLE TYPE	9
III. TOOLS REQUIRED (CUSTOMER SUPPLIED).....	11
1. Tools for Air Pressure Sensor(s) installation	11
2. Tools for Deflection Sensor Installation.....	11
IV. INSTALLING THE QUICKLOAD SCALE.....	12
1. Installing the QuickLoad Display.....	12
A. Preparing the QuickLoad Display for Installation.....	12
B. Mounting the QuickLoad Display.....	12
2. Connecting the QuickLoad Wiring Harness	13
A. Connecting the QuickLoad to Power	13
B. Connecting the QuickLoad to Sensors and Alarms ...	14
B. Secure Cables and Reassemble the Dash	14
3. QuickLoad Connection Diagrams	15
V. INSTALLING AIR SUSPENSION SENSOR(S)	19
1. Air Line Installation for each leveling valve.....	19
A. Route Air Line from Air Suspension	19
B. Routing Air line for Dedicated Tractor / Trailer Scale	20
2. Installing Sensor(s).....	23
A. Installing Air Pressure Sensor (s).....	23
B. Installing Scales with a Steer Axle Deflection Sensor	25
C. Parts and Sensor Configuration Tables	26

- 3. Setting the QuickLoad’s Sensor Configuration 31
 - A. Front Panel Buttons..... 31
 - B. Entering the Sensor Configuration 32
- VI. FOR FURTHER INFORMATION.....33**
- LIMITED WARRANTY34**

I. SCALE OVERVIEW

The Air-Weigh® QuickLoad Scale™ for trucks and tractors with AP (Air Pressure) drive suspension includes a dashboard-mounted a QuickLoad display, power harness, sensor cable(s), and sensor(s) with mounting hardware.

This **Installation Guide** (p/n: 901-0123-000) gives instructions for scale installations on vehicles having air or spring drive suspensions, possibly in combination with air or spring steer suspensions. It also includes dedicated tractor and trailer configurations. See **Table 7. Kit Configuration Sensor Assignment** for more detail on the various vehicle configurations.

Follow Air-Weigh’s installation procedures exactly for the most accurate weighing.

The **User Guide** (p/n: 901-0124-000), included also with the scale, provides the complete scale calibration and operation procedures. These procedures include, among others, the steps for setting up the scale for your specific sensor configuration.

Table 1. Specifications

QuickLoad Scale	<ul style="list-style-type: none">• Diameter: 2.43 inches (61.7 mm)• Height: 3.10 inches (78.7 mm)• Weight: 4.7 oz. (133 g)• Operating Temperature Range: -4° to 158°F (-20° to 70°C)• Input voltage: 9.5V DC to 32V DC• Alarm Output Circuit Limit: 1.0 amps
Weigh Reading Accuracy	<ul style="list-style-type: none">• Axle with Air Sensor: ±300 lbs (140 kgs) per axle group• Axle with Deflection Sensor: ±2% maximum axle group weight

1. QuickLoad Tractor Scale Overview

The QuickLoad scale converts tractor and trailer suspension loads to an accurate on-ground weight by comparing empty and loaded axle group weights with empty and loaded sensor output. Once calibrated, the scale displays accurate weights for any air suspension load.

The scale displays the actual on-ground weight of each axle group to within 300 pounds (140 kilograms) for air suspensions, or $\pm 2\%$ of maximum axle group weight for spring suspensions. An axle group is defined by the Height Control Valve(s) (HCV), or leveling valve(s), on the air suspension, or as the set of axles supporting a spring suspension. For instance, a tandem drive axle suspension typically has only one HCV. The two drive axles make up a single group and the displayed weight will be for the total tandem weight.

The QuickLoad scale can display up to four axle groups on one tractor/trailer combination. Once the QuickLoad is calibrated for weight, it is not necessary to recalibrate unless the suspension characteristics change.

NOTE

Following installation, you must calibrate the scale before you can use it to determine axle group and vehicle weight. For instructions on calibration, please consult p/n 901-0124-000, QuickLoad Calibration and Operations Manual.

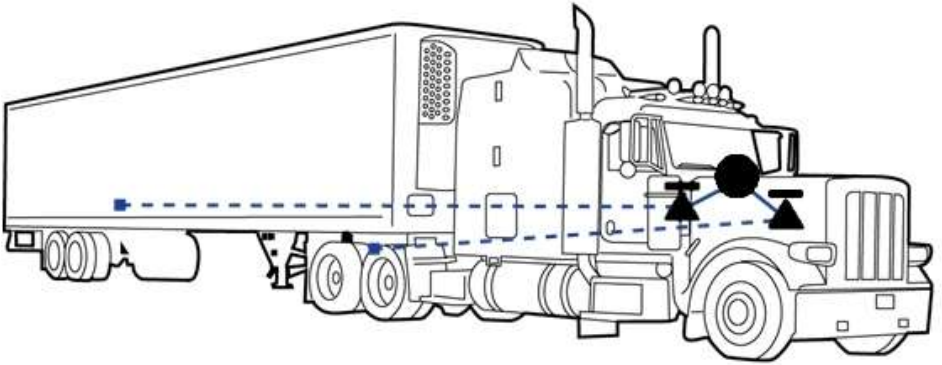

Figure 1. Air Pressure Drive Sensor Hookup

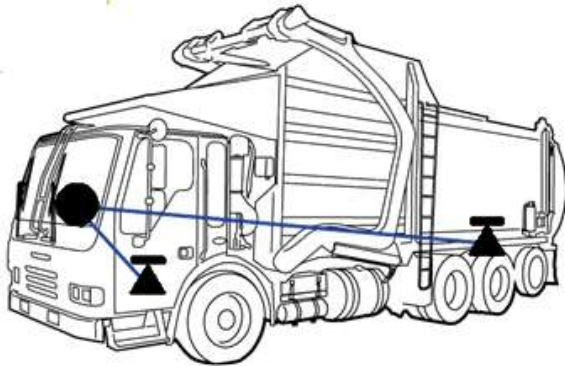

Figure 2. Deflection Sensor Drive Sensor Hookup

-  QuickLoad Scale
-  Sensor
-  Sensor Wiring
-  Air Line

Legend:

2. Installation Overview for QuickLoad Scale System

This guide will give all necessary details of the following steps for installing the QuickLoad Scale System.



CAUTION

Air lines and cables to the sensor, and any other Air-Weigh wiring, must be separated by a minimum of 12 inches, or properly shielded, from exhaust piping.

NOTE

Ensure that each sensor's electrical cable is connected to the correct QuickLoad port. For a list of the correct port for each sensor, see Table 7, page 22.

A. Overview for Electronic Components Installation

- Cut hole in dash for display; mount QuickLoad to dash.
- OR –
- Mount QuickLoad in pod on top of dash, using the optional pod mounting kit, P/N: 1225.

B. Overview for Air Pressure Sensor(s) Installation

- For air suspension scales with air bag(s) on the drive suspension, install air pressure sensor(s) under dash.
- Route air line(s) from drive suspension to sensor(s) installed under dash.
- For scales which calculate the weight at the steer axle from the drive axle suspension (configurations 5800, 5801, 5841, 5845, 5851, 5855, 5860), no steer axle sensor is needed.

- For scales where the steer axle weight is intentionally not displayed (configurations 5803, 5809, 5810, 5816, 5840, 5844, 5850, 5854), no steer axle sensor is needed.
- For scales with a steer axle with air suspension (configurations 5805, 5806, 5815, 5821, 5826, 5827, 5838, 5842, 5847, 5852, 5856), route air line(s) from steer axle suspension to sensor(s) installed under dash.
- For scales which determine the weight at the lift axle (configurations 5833 – 5836, 5838, 5839 and 5864), refer to p/n 901-0117-000, **Application Note, LoadMaxx, Installing and Calibrating the Lift Axle**, for lift axle sensor installation instructions.
- For Dedicated Tractor/Trailer Scales (configurations 5840 – 5857 except 5849), route trailer suspension air line(s) to sensor(s) installed under dash.

C. Overview for Deflection Sensor(s) Installation

- For scales that include steer axle deflection sensors (configurations 5807, 5808, 5814, 5817, 5820, 5822, 5823, 5825, 5828, 5829, 5831, 5833, 5834, 5835, 5836, 5839, 5843, 5846, 5853, 5857 and 5864), refer to p/n 901-0059-000, **Steer Axle Deflection Sensor Kit Installation Guide**, for installation instructions.
- For scales that include dual drive axle deflection sensors on Hendrickson™ HaulMaxx or HN 462/463 suspensions (configurations 5810, 5814, 5818, 5824, 5829 or 5833), refer to p/n 901-0092-000, **Drive Axle Dual Deflection Sensor Installation Guide**.
- For scales that include a single drive axle deflection sensor (configurations 5807, 5708, 5817, 5833 – 5836, 5839, 5843, 5853), contact Air-Weigh.

II. QUICKLOAD PARTS PER VEHICLE TYPE

The most popular QuickLoad parts are shown in Table 2, below. See Table 6 for a comprehensive listing of all QuickLoad parts.

The Air Line and Disconnect kits in Table 2 are optional. They are needed only if the vehicle does not already have those air lines and disconnects, bringing air pressure from the air suspension to behind the dash, already in place.

Table 2: QuickLoad Part Numbers

Part Number	Description
1350	QuickLoad Display Kit which includes the display, mounting hardware, power cable, and user manual.
1360	QuickLoad Air Sensor Kit which includes a single air pressure sensor, push-in fittings, and a 3' cable.
1361	QuickLoad Air Sensor Kit which includes dual air pressure sensors, push-in fittings, two 3' cables and a Y Cable. For 3-sensor and 4-sensor systems only.
1380	QuickLoad Alarm Kit.
1390	Deflection Sensor Kit which includes 15' sensor cable, mounting brackets, and installation manual.
010-0023-000	Air Line Kit (optional)
010-0028-002	Trailer Disconnect Kit (optional)
010-0029-002	Two Trailer Disconnect Kit (optional)

QuickLoad parts per vehicle type, for the most popular software configurations, are shown in Table 3, following. See Table 7 for a comprehensive listing of QuickLoad parts for all vehicle types.

All configurations require P/N 1350, QuickLoad Display Kit, which is not otherwise shown in the following table.

Table 3: QuickLoad Parts for the Most Popular Vehicle Configurations

Vehicle Description	Drive Suspension	Steer	Trailer Suspension	Parts Needed	Software Config
Tractor	Air-Ride Single HCV	Leaf Spring, Calculated to 1%	Not Included	1 ea. 1360	5800
Tractor	Air-Ride Dual HCV	Leaf Spring, Calculated to 1%	Not Included	2 ea. 1360	5801
Truck	Air-Ride Single HCV	Leaf Spring, Not Displayed	Not Included	1 ea. 1360	5803
Tractor	Air-Ride Single HCV	Air-Ride Single HCV	Not Included	2 ea. 1360	5805
Truck	Air-Ride Single HCV	Leaf Spring, Deflection Sensor	Not Included	1 ea. 1360 1 ea. 1390	5807
Dedicated Tractor Trailer	Air-Ride Single HCV	Leaf Spring, Not Displayed	Air-Ride Single HCV	2 ea. 1360	5850
Dedicated Tractor Trailer	Air-Ride Single HCV	Leaf Spring, Calculated to 1%	Air-Ride Single HCV	2 ea. 1360	5851

III. TOOLS REQUIRED (CUSTOMER SUPPLIED)

1. Tools for Air Pressure Sensor(s) installation

- Screwdrivers – flathead and/or Philips
- Assorted wrenches
- Drill
- 2 1/8" hole saw
- Optional 3/4" hole saw for running air line to dash
- Safety glasses
- Wire cutter
- Crimper
- Teflon™ pipe thread tape

2. Tools for Deflection Sensor Installation

- Sander with 40-grit medium
- Chalk or permanent marker
- Flat blade screwdriver
- 9/16-inch combination wrench
- Torque wrench, 20 – 80 ft-lb
- 9/16-inch deep well socket with 3/8-inch socket handle
- 1/2-inch to 3/8-inch socket adapter

Optional:

- Deflection Sensor Field Test Set

The Deflection Sensor Install Field Test Set, p/n 1000, can measure raw deflection sensor readings without the sensor's connection to the QuickLoad Scale.

NOTE

For installation of the steer axle deflection sensor, refer to p/n 901-0059-000, **Steer Axle Deflection Sensor Kit Installation Guide**, which is included in kits 1390 and 1391.

NOTE

For installation of the Hendrickson Walking Beam drive axle deflection sensors, refer to p/n 901-0092-000, Steer Axle Deflection Sensor Kit Installation Guide, which is included in kit 1392.

IV. *INSTALLING THE QUICKLOAD SCALE*

The installation of an Air-Weigh QuickLoad Scale on a vehicle includes mounting two major classes of components:

- Electronics components: QuickLoad display and power interface cable
- Sensor(s) and sensor cable(s)

1. Installing the QuickLoad Display

A. Preparing the QuickLoad Display for Installation

Numbers called out in refer to Figure 3 unless otherwise stated.

1. Select a location for the display (1) on the dash panel (5) with at least 3-inch clearance behind the dash panel for the unit and its connections. A higher dash position provides better visibility.
2. Cut a 2 $\frac{1}{8}$ -inch hole (2) in the dash at that location.
3. Remove the hex nuts (4) from the studs (6) on the back of the display (1) to release the mounting bracket (3).

B. Mounting the QuickLoad Display

1. Position the display (1) in the hole (2) so that it appears level on the dash, as shown in **Figure 3**.
2. Reinstall the mounting bracket (3) on the back of the display and secure with two nuts (4) on the display studs (6). Tighten the nuts and secure the display to the dash using 6 ft-lbs. of torque. **Do not over tighten the mounting bracket nuts.**

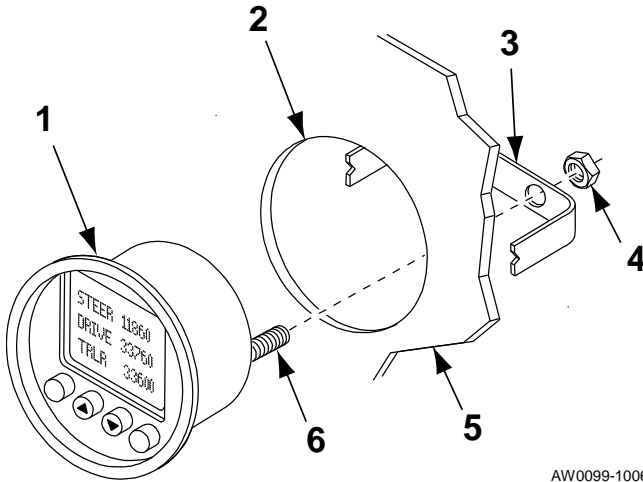

AW0099-1006

Figure 3. Installing the Display

2. Connecting the QuickLoad Wiring Harness

A. Connecting the QuickLoad to Power

The QuickLoad power wiring harness, p/n 012-0600-008, connects the QuickLoad scale to the vehicle's power and ground circuits. Consult Table 4.

Table 4. Wiring Harness Hookup

Power and Ground Table	
White wire	Vehicle chassis ground
Blue/Black wire with in-line fuse	12VDC or 24VDC ignition hot power

1. Connect the **white** wire to chassis **ground**.
2. Connect **blue/black** wire with **inline fuse** to the positive (+) or "hot" side of the 12 VDC or 24 VDC ignition power source. **DO NOT connect directly to battery.**

B. Connecting the QuickLoad to Sensors and Alarms

1. Connect the 4-pin sensor cable(s) to the QuickLoad Sensor Inputs A, B, or C/D, as indicated in the Sensor Connection figures, pages 15-17.
2. To connect an external alarm using the QuickLoad Alarm Kit (p/n 1380), consult the QuickLoad Alarm Kit Manual, included in the Alarm Kit.
 - a) Connect the 4-pin sensor cable with alarm lead to the QuickLoad Sensor Input specified in the Sensor Connection figures, pages 15-17.
 - b) Connect the sensor cable alarm lead to the end of the alarm cable.
 - c) Connect the alarm (or alarm light) power wire to a 12V/ 24V ignition hot source.
3. Turn on key for system self-test. If system does not successfully complete the self-test, see Troubleshooting Section at the end of this manual.

B. Secure Cables and Reassemble the Dash

1. Coil excess wires and harnesses and secure using nylon cable ties.
2. Tie wires and sensor assemblies to other secured harnesses, to prevent damage due to vibration.
3. Reassemble the dash assembly. Ensure all connections are tight.
4. Turn the ignition key **ON** and perform a final system check.

3. QuickLoad Connection Diagrams

Please reference **Table 7. Kit Configuration Sensor Assignment**, for the sensor configuration required for your installation. The following figures give a view of the connectors on the back face of the QuickLoad Scale. They show where the ports for the different configurations mentioned in Table 7 are located.

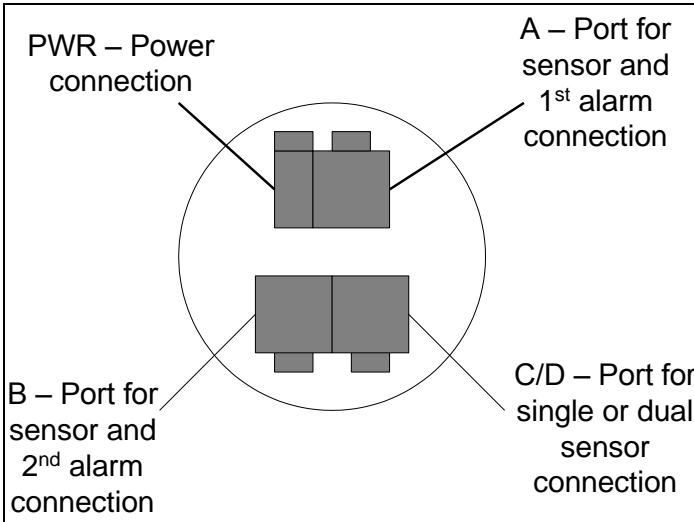

Figure 4. QuickLoad sensor and alarm ports

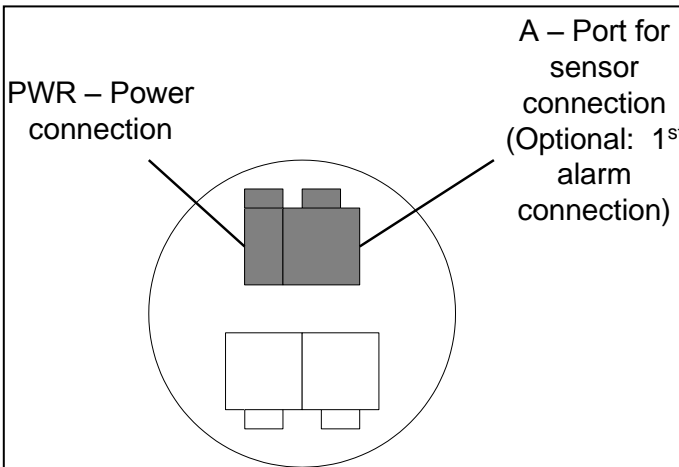

Figure 5. Connections for single sensor system

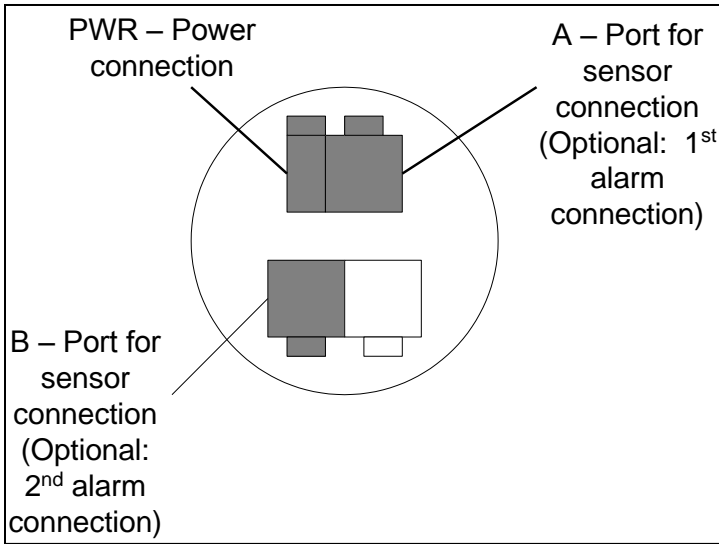

Figure 6. Connections for a two sensor system

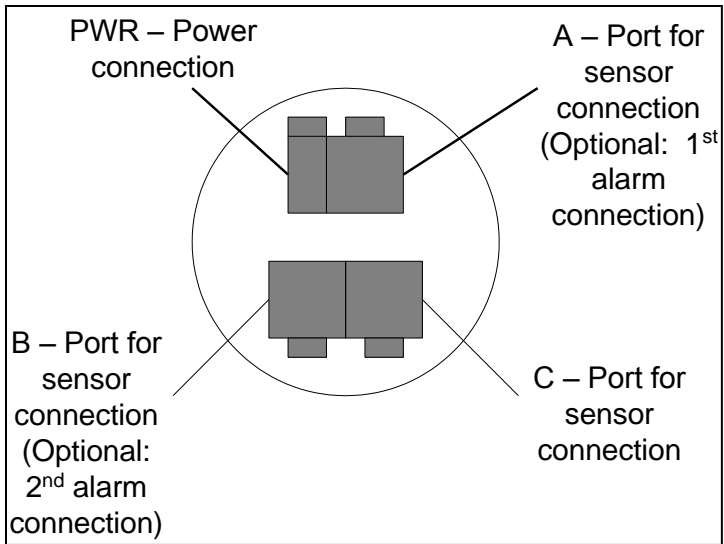

Figure 7. Connections for most three sensor systems (excludes 5821 and 5828)

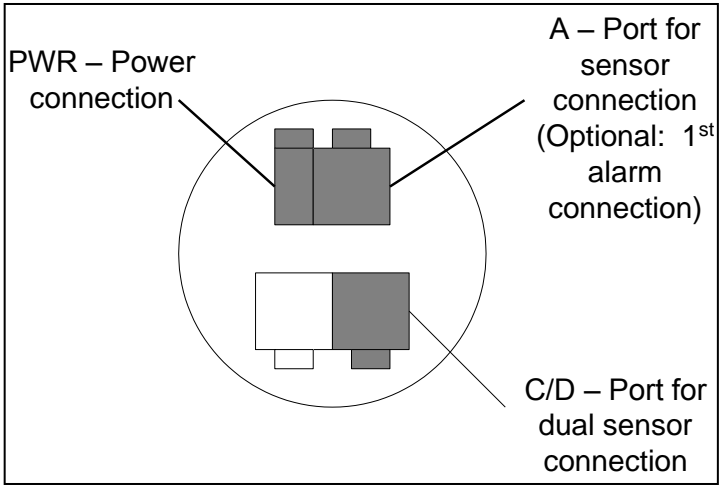

Figure 8. Connections for configurations 5821 and 5828

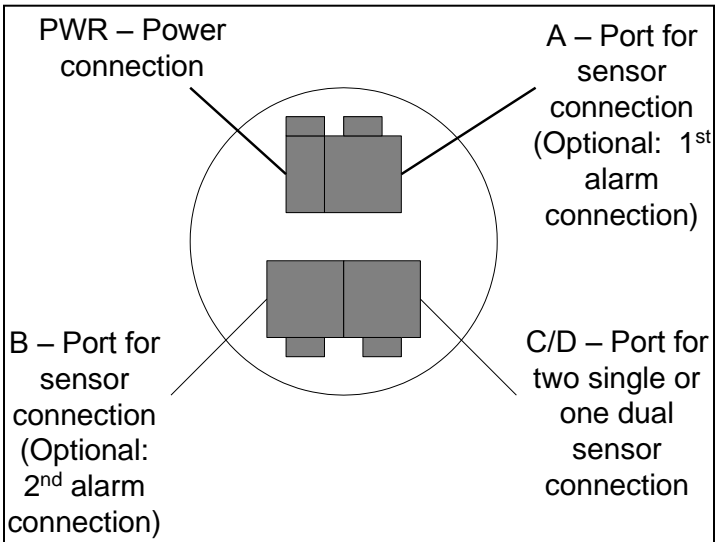

Figure 9. Connections for four sensor system

NOTE

The scale will only display accurate weights after it has been completely calibrated to a certified platform scale, by entering empty and loaded axle weights into the Air-Weigh Scale. *Enter empty weights only when the vehicle is empty! Enter loaded weights only when the vehicle is loaded!*

See QuickLoad Calibration and Operations Manual, p/n 901-0124-000, for complete instructions.

V. INSTALLING AIR SUSPENSION SENSOR(S)

1. Air Line Installation for each leveling valve

A. Route Air Line from Air Suspension

Follow the same instructions for air line and sensor installation for both drive and steer air suspensions. The parts in this section's instructions are listed in **Table 5**.

If an Air Suspension Gauge for the suspension already exists in dash, skip to **V.2, Installing Sensor(s)**. Otherwise, continue with this procedure.

1. Route a ¼-inch air line from the airbag suspension to the dash.

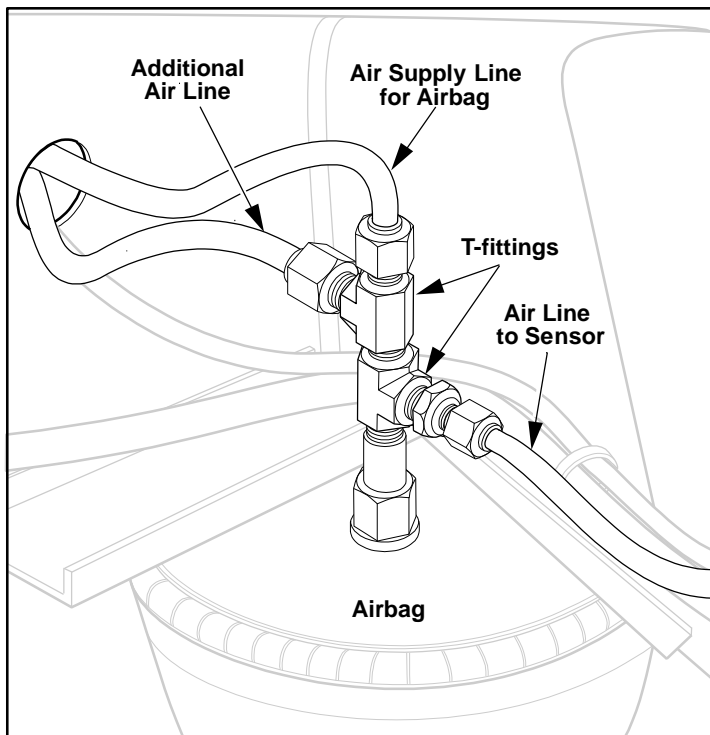

Figure 10. Airbag and Air Line Connections

2. Use a ¼-inch straight street-T at the top of a convenient drive axle suspension air bag to access

air pressure. If you choose to connect in the middle of an existing air line between two air bags, thoroughly remove any paint on the air line and wipe clean before cutting the air line.

3. Route the air line along with other air lines and cables into the dash. Loosely connect the air line to the other air lines and cable with cable ties to prevent it from being damaged.

NOTE

Avoid connecting on the air bag's supply line.

B. Routing Air line for Dedicated Tractor / Trailer Scale

The parts in this section's instructions are listed in Table 5. If Trailer Suspension gauge already exists in dash, skip to V.2, Installing Sensor(s).

Table 5. Air Line and Disconnect Kit BOMs

Bill of Materials for Suspension Air Line Kit, p/n 010-0023-000		
PART NUMBER	DESCRIPTION	QTY
145-4552-001	NYLON TIE, 7", T-50, NYLON, BLK	25
150-4081-000	¼ NPT STREET TEE, DOT, BRASS	1
150-4083-000	DOT COMPRESSION, ¼ NPT, MALE, BRASS	1
380-0046-000	40' X ¼" SAE J844 DOT TUBING	1
BOM for Trailer-Direct Disconnect Kit, p/n 010-0028-002		
145-4552-001	NYLON TIE, 7", T-50, NYLON, BLK	25
150-4081-000	¼ NPT STREET TEE, DOT, BRASS	1
150-4083-000	DOT COMPRESSION, ¼ NPT, MALE, BRASS	3

150-4091-000	FITTING, BRASS, QUICK COUPLER, MALE	1
150-4092-000	FITTING, BRASS, ADAPTER PLUG,FEMALE	1
152-0001-000	BULKHEAD FITTING, 1/4" NPT	2
380-0050-000	100' X 1/4" SAE J844 DOT TUBING	1
380-0053-000	AIR HOSE, COILED, 1/4" NPT X 2, 25'	1
901-0052-000	INSERT, AW5800, TRAILER-DIRECT	1
BOM for Two-Trailer-Direct Disconnect Kit, p/n 010-0029-002		
145-4552-001	NYLON TIE, 7", T-50, NYLON, BLK	50
150-4081-000	1/4 NPT STREET TEE, DOT, BRASS	2
150-4083-000	DOT COMPRESSION, 1/4 NPT, MALE,BRASS	8
150-4091-000	FITTING, BRASS, QUICK COUPLER, MALE	3
150-4092-000	FITTING, BRASS, ADAPTER PLUG,FEMALE	3
152-0001-000	BULKHEAD FITTING, 1/4" NPT	6
380-0046-000	40' X 1/4" SAE J844 DOT TUBING	1
380-0050-000	100' X 1/4" SAE J844 DOT TUBING	2
380-0053-000	AIR HOSE, COILED, 1/4" NPT X 2, 25'	3
901-0065-000	INSERT, AW5800, TWO-TRAILERS-DIRECT	1

1. Remove existing air line connection from one trailer air bag.
2. Install street-T (p/n: 150-4081-000) into air bag.
3. Install fitting (p/n: 150-4083-000) into side of street-T and connect to air line (p/n: 380-0050-000).
4. Reinstall original air line and fitting connector to top of street-T.

5. Run air line (p/n: 380-0050-000) to front of trailer. Secure with cable ties.
6. Drill hole for trailer bulkhead fitting at a point near where existing airlines attach to trailer.
7. Install bulkhead fitting (p/n: 152-0001-000).
8. Cut air line to length and connect to rear side of bulkhead fitting. Use remaining air line in step 13.
9. Attach female quick-disconnect coupling (p/n: 150-4092-000) to face of bulkhead fitting.

NOTE

Female coupling MUST be connected to trailer air line to keep air in suspension system.

10. Connect end of coiled air line (p/n: 380-0053-000) with male quick disconnect coupling to female quick disconnect coupling (p/n: 150-4092-000). See **Figure 11**.

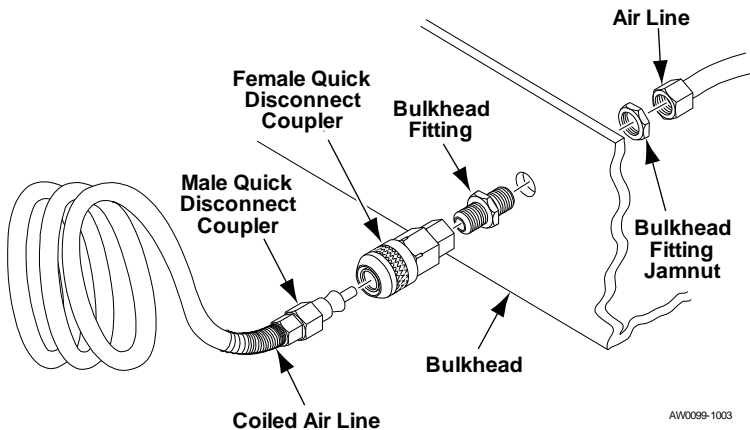

Figure 11. Installing Bulkhead Connector

11. Attach quick disconnect fitting (p/n: 150-4091-000) to one end of coiled air hose and couple to quick

disconnect fitting (p/n: 150-4092-000) on front bulkhead of trailer. See **Figure 11**.

12. Drill hole in tractor bulkhead near where existing air lines attach to the tractor and install bulkhead fitting (p/n: 152-0001-000).
13. Connect the other end of the coiled air line (p/n: 380-0053-000) to the face of the bulkhead fitting.
14. Install brass fitting (p/n: 150-4083-000) into rear of bulkhead fitting. Run air line (380-0050-000) from brass fitting to under dash, close to QuickLoad mounting location. Secure with wire ties.
15. Connect open end of air line, near QuickLoad, to push-on fitting on end of Air Pressure Sensor.
16. Connect electrical cable from opposite end of air pressure sensor to appropriate port on QuickLoad. See **Table 7. Kit Configuration Sensor Assignment** to determine the appropriate port for the sensor connector.

2. Installing Sensor(s)



Avoid dropping the sensors. Dropping can cause the sensors to fail immediately or shorten their lifespan.

A. Installing Air Pressure Sensor (s)

There are two methods of installing the sensor connections to the suspension air line(s) under the dash. See **Figure 12. Connecting the Air Pressure Sensor**

1. Insert a T-fitting into an existing suspension air gauge.
2. Terminate the air line into the nickel plated brass fitting supplied by Air-Weigh.

The Air-Weigh kit includes fittings for terminating air lines of either of two diameters, 1/4-inch and 5/32-inch. The customer will need to purchase additional fittings to insert a T-fitting into an existing air line. Air-Weigh only supplies the connectors needed for a terminated connection.

1. Connect sensor to fitting and tighten. Using a torque wrench, set torque to approximately 25 ft-lbs.
2. Push end of air line into fitting and ensure connection is firmly secured.

NOTE

While the air line can be removed from the fitting by retracting the O-ring while gently pulling the air line out, repeated removal and replacement will weaken the seal.

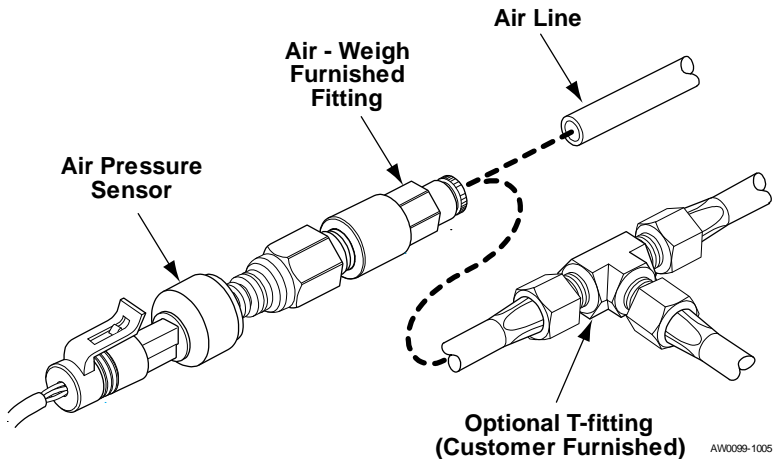

Figure 12. Connecting the Air Pressure Sensor

NOTE

Female coupling **MUST** be connected to trailer air line to keep air in the air bag suspension system.

B. Installing Scales with a Steer Axle Deflection Sensor

NOTE

When installing kits with configurations 5807, 5808, 5843, 5846, 5853, 5857 or 5878, which include steer axle deflection sensors, refer to p/n 901-0059-000, Steer Axle Deflection Sensor Kit Installation Guide, for installation instructions.

NOTE

For installation of the Hendrickson Walking Beam drive axle deflection sensor, refer to p/n 901-0092-000, Steer Axle Deflection Sensor Kit Installation Guide, which is included in kit 1392.

NOTE

For installation of the Volvo T-Ride drive axle deflection sensor, refer to p/n 901-0125-000, Installation Guide for Vocational Vehicles with Volvo T-Ride Suspensions, which is included in kit 1397.

C. Parts and Sensor Configuration Tables

All configurations require P/N 1350, QuickLoad Display Kit, which is not otherwise shown in the following table.

Table 6. QuickLoad Parts for Each Vehicle Configuration

Vehicle Description	Drive Suspension	Steer	Trailer Suspension	Parts Needed	Software Config
Tractor	Single HCV	Calculated	Not Included	1 ea. 1360	5800
Tractor	Dual HCV	Calculated	Not Included	2 ea. 1360	5801
Truck	Single HCV	Hide steer	Not Included	1 ea. 1360	5803
Tractor	Single HCV	Single HCV	Not Included	2 ea. 1360	5805
Tractor	Dual HCV	Single HCV	Not Included	3 ea. 1360	5806
Truck	Single HCV	Def Sensor	Not Applicable	1 ea. 1360 1 ea. 1390	5807
Truck	Dual HCV	Def Sensor	Not Applicable	2 ea. 1360 1 ea. 1390	5808 or 5878
Tractor	Dual Def Sensor	Hide	Not Included	1 ea. 1392	5810
Tractor	Dual Def Sensor	Def Sensor	Not Applicable	1 ea. 1390 1 ea. 1392	5814
Tractor	Dual HCV	Dual HCV	Not Included	2 ea. 1360 1 ea. 1361	5815
Tractor	Dual HCV	Dual HCV	Not Included	2 ea. 1360 1 ea. 1361	5815
Tractor	Dual HCV	Hide steer	Not included	2 ea. 1360	5816
Truck	Def Sensor	Def Sensor	Not included	1 ea. 1390 1 ea. 1397	5817
Truck	Dual HCV	Dual Def Sensor	Not Included	2 ea. 1360 1 ea. 1390 1 ea. 1393	5825
Truck	Single HCV	Dual Def Sensor	Not Applicable	1 ea. 1360 1 ea. 1390 1 ea. 1393	5828
Truck with lift axle air sensor	Dual Def Sensor	Def Sensor	Not applicable	1 ea. 1360 1 ea. 1390 1 ea. 1392	5833
Truck with lift axle air sensor	Def Sensor	Def Sensor	Not Applicable	1 ea. 1360 1 ea. 1390 1 ea. 1397	5834
Truck with lift axle air sensor	Single HCV	Def Sensor	Not Applicable	2 ea. 1360 1 ea. 1390	5835
Truck with lift axle air sensor	Dual HCV	Def Sensor	Not Applicable	1 ea 1360 1 ea 1361 1 ea 1390	5836

Vehicle Description	Drive Suspension	Steer	Trailer Suspension	Parts Needed	Software Config
Truck with lift axle air sensor	Single HCV	Single HCV	Not Applicable	3 ea. 1360	5838
Truck with two lift axle air sensor	Def Sensor	Def Sensor	Not Applicable	2 ea. 1360 1 ea. 1390 1 ea. 1397	5839
Two Trailer Direct	Single HCV	Hide Steer	Two; each with single HCV	3 ea. 1360	5840
Two Trailer Direct	Single HCV	Calculated	Two; each with single HCV	3 ea. 1360	5841
Two Trailer Direct	Single HCV	Single HCV	Two; each with single HCV	2 ea. 1360 1 ea. 1361	5842
Two Trailer Direct	Single HCV	Deflection Sensor	Two; each with single HCV	1 ea. 1360 1 ea. 1361 1 ea. 1390	5843
Two Trailer Direct	Dual HCV	Hide Steer	Two; each with single HCV	2 ea. 1360 1 ea. 1361	5844
Two Trailer Direct	Dual HCV	Calculated	Two; each with single HCV	2 ea. 1360 1 ea. 1361	5845
Dedicated Tractor Trailer	Single HCV	Hide Steer	Single HCV	2 ea. 1360	5850
Dedicated Tractor Trailer	Single HCV	Calculated	Single HCV	2 ea. 1360	5851
Dedicated Tractor Trailer	Single HCV	Single HCV	Single HCV	3 ea. 1360	5852
Dedicated Tractor Trailer	Single HCV	Deflection Sensor	Single HCV	2 ea. 1360 1 ea. 1390	5853
Dedicated Tractor Trailer	Dual HCV	Hide Steer	Single HCV	3 ea. 1360	5854
Dedicated Tractor Trailer	Dual HCV	Calculated	Single HCV	3 ea. 1360	5855
Dedicated Tractor Trailer	Dual HCV	Single HCV	Single HCV	2 ea. 1360 1 ea. 1361	5856
Dedicated Tractor Trailer	Dual HCV	Calculated	Dual HCV on Trailer	2 ea. 1360 1 ea. 1361	5860
Truck with two lift axle air sensor	Single HCV	Def Sensor	Not Applicable	3 ea. 1360 1 ea. 1390	5864

Table 7. Kit Configuration Sensor Assignment

Number See Kit Part Number for Model Number	Sensor Installed on this Suspension HCV = Height Control Valve	Sensor Type AP = Air Pressure Sensor DS = Deflection Sensor LC = Load Cell	QuickLoad Sensor Cable Input Jack
5800	Drive	AP	Sensor A
5801	Drive, Dual HCV's	AP, AP	Sensor A & B
5803	Drive, Hide Steer	AP	Sensor A
5805	Drive	AP	Sensor A
	Steer	AP	Sensor B
5806	Drive, Dual HCV's	AP, AP	Sensor A & B
	Steer	AP	Sensor C
5807	Drive	AP	Sensor A
	Steer	DS	Sensor B
5808	Drive, Dual HCV's	AP, AP	Sensor A & B
	Steer	DS	Sensor C
5810	Drive, Dual Defl'n Sensors	DS, DS	Sensor A & B
5814	Drive, Dual Defl'n Sensors	DS, DS	Sensor A & B
	Steer	DS	Sensor C
5815	Drive, Dual HCV's	AP, AP	Sensor A & B
	Steer, Dual HCV's	AP, AP	Sensor C & D
5816	Drive, Dual HCV's, Hide Steer	AP, AP	Sensor A & B
5817	Drive	DS	Sensor A
	Steer	DS	Sensor B
5818	Drive, Dual Defl'n Sensors	DS, DS	Sensor A & B
	Steer, Dual HCV's	AP, AP	Sensor C & D
5820	Drive, Load Cell	LC	Sensor A
	<not used>	N/A	Sensor B
	Steer, Dual DS's	DS, DS	Sensor C & D
5821	Drive	AP	Sensor A
	<not used>	N/A	Sensor B
	Steer, Dual HCV's	AP, AP	Sensor C & D
5822 DRIV1/DRIV2	Drive	AP	Sensor A
	Steer	DS	Sensor B
5823 DRIV1/DRIV2	Drive, Dual HCV's	AP, AP	Sensor A & B
	Steer	DS	Sensor C
5824	Drive, Dual DS's	DS, DS	Sensor A & B
	Steer	AP	Sensor C
5825	Drive, Dual HCV's	AP, AP	Sensor A & B
	Steer, Dual DS's	DS, DS	Sensor C & D
5826	Drive	AP	Sensor A
	Steer	AP	Sensor B
5827	Drive, Dual HCV's	AP, AP	Sensor A & B
	Steer	AP	Sensor C

Number See Kit Part Number for Model Number	Sensor Installed on this Suspension HCV = Height Control Valve	Sensor Type AP = Air Pressure Sensor DS = Deflection Sensor LC = Load Cell	QuickLoad Sensor Cable Input Jack
5828	Drive	AP	Sensor A
	<not used>	N/A	Sensor B
	Steer, Dual Defl'n Sensors	DS, DS	Sensor C & D
5829	Drive, Dual DS's	DS, DS	Sensor A & B
	Steer, Dual DS's	DS, DS	Sensor C & D
5830 Trk Payload	Drive	AP	Sensor A
	Steer	HY	Sensor B
Trailer Direct 5831	Drive	LC	Sensor A
	Steer	DS	Sensor B
	Trailer, Front	AP	Sensor C
	Trailer, Rear	AP	Sensor D
Trailer Direct 5832	Drive	DS	Sensor A
	Trailer	AP	Sensor B
5833	Drive, Dual Defl'n Sensors	DS, DS	Sensor A & B
	Steer	DS	Sensor C
	Lift	AP	Sensor D
5834	Drive	DS	Sensor A
	Steer	DS	Sensor B
	Lift	AP	Sensor C
5835	Drive	AP	Sensor A
	Steer	DS	Sensor B
	Lift	AP	Sensor C
5836	Drive, Dual HCV's	AP, AP	Sensor A & B
	Steer	DS	Sensor C
	Lift	AP	Sensor D
5837	Drive – Front	DS	Sensor A
	Drive – Rear	DS	Sensor B
	Steer – Front	DS	Sensor C
	Steer – Rear	DS	Sensor D
5838	Drive	AP	Sensor A
	Steer	AP	Sensor B
	Lift	AP	Sensor C
5839	Drive	DS	Sensor A
	Steer	DS	Sensor B
	Pusher Lift	AP	Sensor C
	Tag Lift	AP	Sensor D
Trailer Direct 5840	Drive, Hide Steer	AP	Sensor A
	Trailer, Trailer – B-Train	AP, AP	Sensor B & C
Trailer Direct 5841	Drive	AP	Sensor A
	Trailer, Trailer – B-Train	AP, AP	Sensor B & C
Trailer Direct 5842	Drive	AP	Sensor A
	Steer	AP	Sensor B
	Trailer, Trailer – B-Train	AP, AP	Sensor C & D

Number See Kit Part Number for Model Number	Sensor Installed on this Suspension HCV = Height Control Valve	Sensor Type AP = Air Pressure Sensor DS = Deflection Sensor LC = Load Cell	QuickLoad Sensor Cable Input Jack
Trailer Direct 5843	Drive	AP	Sensor A
	Steer	DS	Sensor B
	Trailer, Trailer – B-Train	AP, AP	Sensor C & D
Trailer Direct 5844	Drive, Dual HCV's	AP, AP	Sensor A & B
	Trailer, Trailer – B-Train	AP, AP	Sensor C & D
Trailer Direct 5845	Drive, Dual HCV's	AP, AP	Sensor A & B
	Trailer, Trailer – B-Train	AP, AP	Sensor C & D
Trailer Direct 5846	Drive	LC	Sensor A
	Steer	DS	Sensor B
	Trailer, Trailer – B-Train	AP, AP	Sensor C & D
Trailer Direct 5847	Drive	AP	Sensor A
	Trailer	DS	Sensor B
5849	Drive	DS	Sensor A
	Steer	Calculated	n/a
Trailer Direct 5850	Drive, Hide Steer	AP	Sensor A
	Trailer	AP	Sensor B
Trailer Direct 5851	Drive	AP	Sensor A
	Trailer	AP	Sensor B
Trailer Direct 5852	Drive	AP	Sensor A
	Steer	AP	Sensor B
	Trailer	AP	Sensor C
Trailer Direct 5853	Drive	AP	Sensor A
	Steer	DS	Sensor B
	Trailer	AP	Sensor C
Trailer Direct 5854	Drive, Dual HCV's	AP, AP	Sensor A & B
	Trailer	AP	Sensor C
Trailer Direct 5855	Drive, Dual HCV's	AP, AP	Sensor A & B
	Trailer	AP	Sensor C
Trailer Direct 5856	Drive, Dual HCV's	AP, AP	Sensor A & B
	Steer	AP	Sensor C
	Trailer	AP	Sensor D
Trailer Direct 5857	Drive, Dual HCV's	AP, AP	Sensor A & B
	Steer	DS	Sensor C
	Trailer	AP	Sensor D
Trailer Direct 5860	Drive, Dual HCV's	AP, AP	Sensor A & B
	Trailer, Dual HCV's	AP, AP	Sensor C & D
Trailer Direct 5863	Drive	LC	Sensor A
	Steer	DS	Sensor B
	Trailer	AP	Sensor C
5864	Drive	AP	Sensor A
	Steer	DS	Sensor B
	Pusher Lift	AP	Sensor C
	Tag Lift	AP	Sensor D

3. Setting the QuickLoad's Sensor Configuration

The default sensor configuration for the QuickLoad Display is 5851. (See Table 7, above.) For any other configuration, you must set it yourself. The following gives the necessary background and steps to do this. First, it's a good idea to become familiar with the QuickLoad Display.



Below is a definition of the use of each button. The function and use of these buttons remain the same throughout all operations of the scale.

A. Front Panel Buttons

1. When the QuickLoad Display backlight is off, the first button push turns on the backlight, with no other effect.
2. Depressing the ESC key (with the backlight lit) changes the Weights Display to the Main Menu, depicted above. It changes all other menus and displays to the previous screen.

If you are on another menu, pressing the ESC key repeatedly will bring you to the Main Menu. Pushing it once more will bring you to the Weights Display.

If you are entering a number, depressing the ESC key clears the numeric entry without changing the scale's value.

3. The cursor location on the 5800 is indicated by the blinking line. In the QuickLoad Display images below, an **orange highlight** indicates the cursor location.
4. To change the cursor location, or to set a numeric value, depress the up or down arrow keys ▲ or ▼.
5. The instruction "Select [some menu item]" will appear frequently in the text that follows. To select a menu item, depress the ENTER key after setting the cursor to the specified line, that is, after making the specified line start blinking.
6. To enter a numeric value, depress the ENTER key after setting the value to the desired number.

B. Entering the Sensor Configuration

1. Depress <ESC> one or more times until the Main Menu appears, with VIEW WEIGHTS blinking.



2. Select SETUP,DIAG leading to next menu.
3. Select SYSTEM SETUP, leading to next menu.
4. Select SYS CONFIG, leading to next menu.
5. Select MODEL NUMBER, leading to next menu.



6. The screen pauses with the display, “USE CAUTION! PUSH ENTER TO CONTINUE.”
7. Depress <ENTER>, leading to the MODEL NUMBER menu, initially showing 5851.
8. Using the up/down arrows <▲▼>, scroll to the proper scale configuration identified from Table 7. In the example, this is 5834. The screen will briefly show Accepted to indicate its acceptance of the Model Number.
9. Press <ESC> repeatedly to return to the Main Menu or to the Weights Display.

VI. FOR FURTHER INFORMATION

Included in the Scale Kit:

901-0039-000 – Card, Sensor Configuration, AW5800, BOM Level

901-0041-000 – Card, Quickstart, AW5800, Generic

901-0054-000 – Card, AW5800, Operations, Calibration

901-0124-000 – Manual, QuickLoad, Operations and Calibration

Included in the Trailer-Direct or Two-Trailers-Direct Disconnect Kit:

901-0052-000 – Insert, AW5800, Trailer-Direct

901-0065-000 – Insert, AW5800, Two-Trailers-Direct

901-0100-000 – Insert, QuickLoad, Install Guide

Included in the QuickLoad Alarm Kit (p/n 1380):

901-0094-000 – QuickLoad Alarm Kit: Installation and Programming

Available from Air-Weigh Support:

901-0117-000 – Application Note, Calibrating The Lift Axle

LIMITED WARRANTY

For product failures due to material or manufacturing defects, Air-Weigh will replace or repair all components for up to 3 years from shipment date to the end-user Air-Weigh customer. These three-year components include: Displays, QuickLoads, Air Sensors, Power Cables, Air Sensor Assemblies, Air Sensor Harnesses, and all other associated external components. Air-Weigh assumes no responsibility for administering warranty claims directly with any third party end users. The responsibility of Air-Weigh under this warranty is limited to the repair, replacement, or credit of the defective part or assembly.

This warranty does not cover incidental or consequential damage to persons or property caused by use, abuse, misuse, or failure to comply with installation or operating instructions. This limited warranty does not apply to any product that has failed due to accident, abuse, alteration, installation not consistent with printed installation instructions, improper maintenance, improper operation, or as a result of system integration or installation not explicitly approved in writing by Air-Weigh.

Air-Weigh and its resellers shall have no responsibility or liability for damages if the purchaser or any other person alters the vehicle incorporating Air-Weigh products. This limited warranty shall not apply to any product that has been repaired or altered by anyone not employed by Air-Weigh or not operated in accordance with the manufacturer's printed material delivered with this product.

Air-Weigh hereby expressly disclaims any and all implied warranties of any type, kind of nature whatsoever, particularly any implied warranty of merchantability or fitness for a particular purpose not expressly stated by Air-Weigh in its printed material delivered with its products.

Some states do not allow the exclusion or limitation of incidental or consequential damages. If such laws apply, the limitations or exclusions contained in the terms and conditions of this Warranty may not apply. This warranty gives you specific legal rights and you may also have other rights, which vary state to state.

May be covered by U.S. Patent Nos. 5478974, 5780782, 7478001

Foreign Patent Nos. 260494, 677998, 2122766

Copyright © 2004, 2006, 2007, 2008, 2009, 2010, 2013 by Hi-Tech Transport Electronics, Inc. All rights reserved. Air-Weigh®, QuickLoad™, WireLink™, Weight Gauge™, and Hi-Tech Transport Electronics are trademarks or registered trademarks of Hi-Tech Transport Electronics, Incorporated. Other brand, product, or service names listed in this document are the trademarks or registered trademarks of their respective holders. Information contained in this literature was accurate at time of publication. Product changes may have been made after copyright dates that are not reflected.

PROCEDURE FOR WARRANTY CLAIMS

1. In the event Air-Weigh requests to examine product prior to disposition, OR for repairs or replacements, Air-Weigh requires a Return Material Authorization (RMA) number to be issued before the item is returned. Contact Customer Support Department at (888) 459-3247 for an RMA number. Please reference this RMA number in all correspondence.
2. Claimed items shall be shipped freight pre-paid to: Air-Weigh, Customer Support Department, 1730 Willow Creek Circle, Eugene, Oregon 97402, USA. The Air-Weigh RMA number shall appear on the outside of the return packaging.
3. Air-Weigh shall examine returned material within 30 days after receipt, or sooner if mutually agreed upon. If Air-Weigh determines that the part or assembly was defective in material or workmanship and within the warranty period, Air-Weigh will repair or replace the part or assembly and return freight pre-paid. In the event Air-Weigh determines that the part or assembly cannot be repaired or replaced and is within the warranty period, a credit not to exceed the purchase price will be issued to the Air-Weigh customer.
4. Air-Weigh Accounting will process a credit memo and notify the Air-Weigh customer by email or fax. The Air-Weigh customer will process a corresponding debit memo and notify Air-Weigh Accounting.
5. If the part or assembly received by Air-Weigh does not meet the requirements of the warranty program set forth above, at the Air-Weigh customer's request the part or assembly will either be discarded, returned freight collect, or repaired or replaced at the Air-Weigh customer's expense and returned freight collect.



1730 Willow Creek Circle • Eugene, Oregon 97402-9152 USA
P.O.Box 24308 • Eugene, Oregon 97402-0437 USA

Telephone (541) 343-7884 • Order Desk (888) 459-3444
Customer Support (888) 459-3247 • FAX (541) 431-3121
Hours of Operation: Mon-Fri, 7am – 5pm, Pacific Time

www.Air-Weigh.com