

QJYJ30-ZW Scissor Vehicle Lift Operation Manual

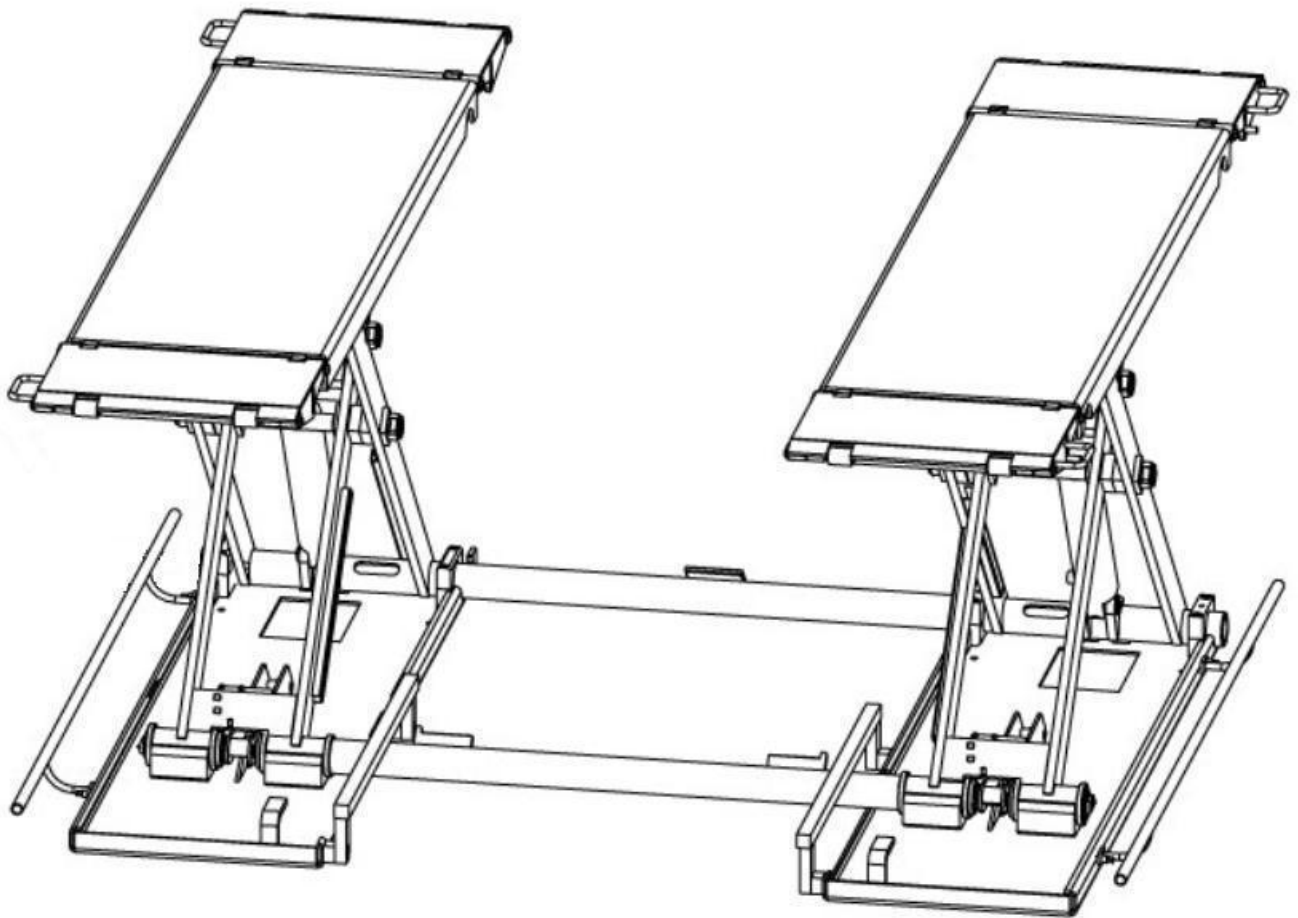

Instructions are part of the product, please place where you can always find for easy reference. Read the instructions carefully before the start of installation, operation and Tongrun lift and its distributors are not liable for any accidents caused by misuse, abuse, alterations on parts, which not authorized by them.

INDEX

1. Important safety instructions.....	1-2
1.1 Important notices	
1.2 Qualified personnel	
1.3 Danger notices	
1.4 Warning signs	
2. Overview of the lift.....	3-4
2.1 General descriptions	
2.2 Technical data	
2.3 Construction of the lift	
3. Installation instructions.....	4-8
3.1 Preparations before installation	
3.1.1 Tools and equipments needed	
3.1.2 List for parts checking	
3.1.3 Ground conditions	
3.2 Precautions for installation	
3.3 Installation	
3.4 Items to be checked after installation	
4. Operation instructions.....	9-11
4.1 Precautions	
4.2 Descriptions of control box	
4.3 Operating instructions	
5. Trouble shooting.....	12
6. Maintenance.....	13-14
7. Annex.....	15-24
Annex 1	Packing list of the whole lift
Annex 2	Overall diagram
Annex 3	Hydraulic working system
Annex 4	Wiring diagram
Annex 5	Diagram for air supply connection
Annex 6	Spare parts list
Annex 7	Separated drawings for the lift

IMPORTANT SAFETY INSTRUCTIONS

1.1 Important notices

- The lift is specially designed for lifting vehicles that weighs within its outmost lifting capacity. Users are not allowed to use it for any other purposes. Otherwise, Tongrun lift, as well as our sales agency, will not bear any responsibility for accidents or damages of the lift.
- Tongrun lift provide one-year's quality warranty for the whole machine. Personal or property damage directly or indirectly caused by improper installation or any abuse, the company does not undertake any responsibility.
- Please read this manual carefully before installation and operation, to avoid any property damage, or life injury caused by improper operation.
- Without our professional advice, users are not permitted to make any modification to the control unit or whatever mechanical unit.

1.2 Qualified personnel

- 1.2.1 Only these qualified staff, who have been properly trained, can operate the lift.
- 1.2.2 Electrical connection must be done by a competent electrician.
- 1.2.3 People who are not concerned are not allowed in the lifting area.

1.3 Danger notices

- 1.3.1 Do not install the lift on any asphalt surface.
- 1.3.2 Read and understand all safety warnings before operating the lift.
- 1.3.3 Do not leave the controls while the lift is still in motion.
- 1.3.4 Keep hands and feet away from any moving parts. Keep feet clear of the lift when lowering.
- 1.3.5 Only these properly trained personnel can operate the lift.
- 1.3.6 Do not wear unfit clothes such as large clothes with flounces, tires, etc, which could be caught by moving parts of the lift.
- 1.3.7 To prevent evitable incidents, surrounding areas of the lift must be tidy and with nothing unconcerned.
- 1.3.8 The lift is simply designed to lift the entire body of vehicles, with its maximum weight within the lifting capacity.
- 1.3.9 Always insure the safety latches are engaged before any attempt to work near or under the vehicle. Never remove safety related components from the lift. Do not use if safety related components are damaged or missing.
- 1.3.10 Do not rock the vehicle while on the lift or remove any heavy component from vehicle that may cause excessive weight shift.
- 1.3.11 Check at any time the parts of the lift to ensure the agility of moving parts and the performance of synchronization. Ensure regular maintenance and if anything abnormal occurs, stop using the lift immediately and contact our dealers for help.
- 1.3.12 Lower the lift to its lowest position and do remember to cut off the power source when service finishes.
- 1.3.13 Do not modify any parts of the lift without manufacturer's advice.
- 1.3.14 If the lift is going to be left unused for a long time, users are required to:
 - a. Disconnect the power source;
 - b. Lubricate the moving parts with hydraulic oil;
 - c. Empty the oil tank.

Warning: lifting machine is of high risk products. Improper installation and operation, or modification on the parts without authorization, are likely to cause damage to the operator, even resulting in death. Read the instructions carefully and strictly operate the lift according to the requirements.

1.4 Warning signs

safety notes!	safety notes!	safety notes!	notes!	notes!
				
Read operating and safety manual before using lift.	Proper maintenance and inspection is necessary for safe operation.	Do not operation a damaged lift.	Lift to be used by trained operator only!	Authorized personnel only in lift area.
notes!	notes!	warning!	warning!	warning!
				
Always use safety stands when removing or installing heavy components.	Please use the lift recommended by the vehicle manufacture.	Without the permission of the manufacturer or not following the requirement of the manual ,any changes in the machine part and in the usage scope is strictly forbidden.	Remain clear of lift when lowering vehicle.	Keep hands and feet clear of X and link of lift while raising and lowering.
warning!	warning!	warning!	warning!	warning!
				
Avoid excessive rocking of vehicle while on lift.	Keep the installation area free from obstacle, grease, machine oil, garbage and other impurities, keep cleaning.	Assistant support or pole under vehicle is forbidden while lowering.	Severe deviation of the center of gravity, leading to unstable vehicle inclining and falling out.	Position only one side of the vehicle is forbidden.
warning!	warning!	warning!	warning!	
				
Keep feet clear of lift while lowering!	Clear area if vehicle is in danger of falling.	The vehicle should be parallel with the table of lift.	Look out the voltage.	

OVERVIEW OF THE LIFT

2.1 General descriptions

QJYJ30-ZW scissor lift is equipped with the trailer-mounted control system which is convenient for speedy repair in outdoor. The scissor lift is suitable for hoisting small and medium-sized vehicles which is below 3.0 ton to conduct repair and maintenance of various types of vehicles.

Power unit is driven by hydraulic system. And hydraulic oil will be driven to the hydraulic cylinder by gear pump, which drive piston rod to lift vehicle. The machine is equipped with mechanical safety lock and both the left and right side of the bottom plate is fixed with a preventing overturn, this makes the machine safer.

Safety structure:

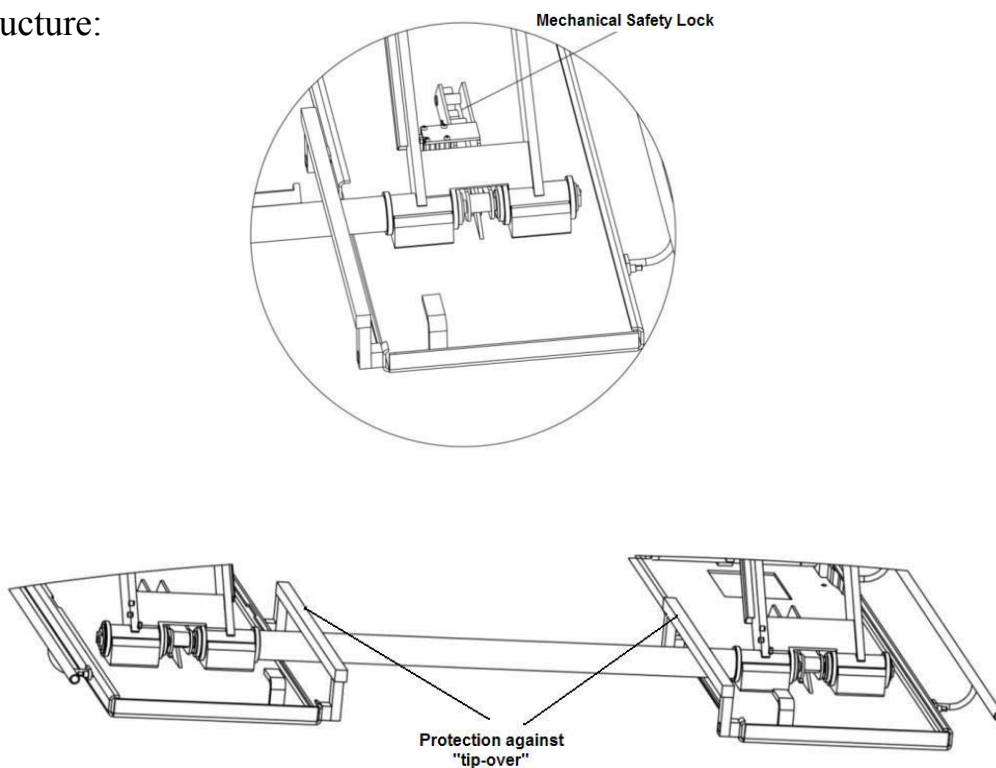

2.2 Technical data

Model	Lifting capacity	Lifting time	Fall time	Lifting height	Total weight	Power supply
QJYJ30-ZW	3000KG	<50s	>20s	1000mm	480KG	220V, Single-phase 380V, three-phase

2.3 Construction of the lift

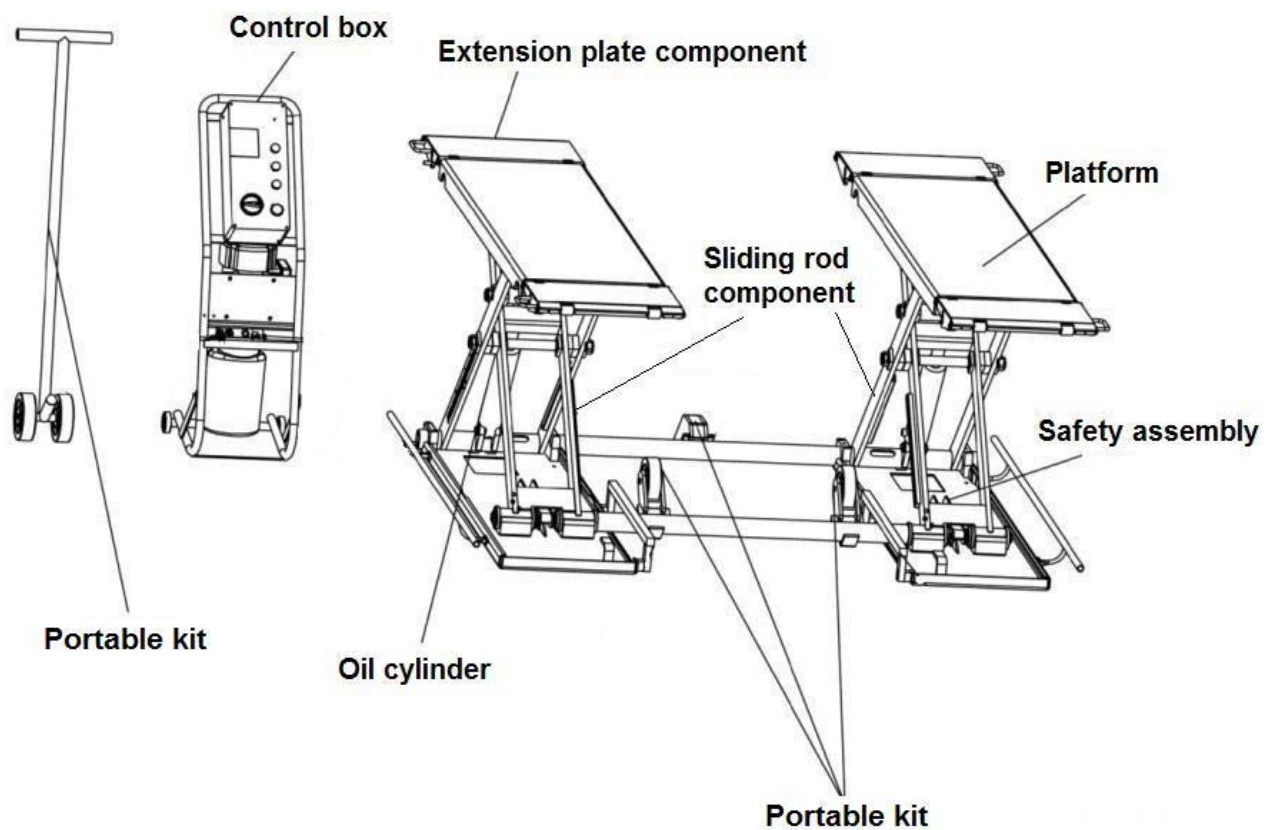

INSTALLATION INSTRUCTIONS

3.1 Preparations before installation

3.1.1 Tools and equipments needed

- Electrical drill
- Open wrenches
- Screw drivers
- Hammer

3.1.2 List for parts checking --- Annex 1(Packing list)

Open the package, refer to the attachment 1 (packing list), check all parts, if any parts missing happen, please contact the dealer or manufacturer immediately. In this case, you should not continue installation. Otherwise Tongrun lift and distributors are not liable.

3.1.3 Ground conditions

The lift should be fixed on a smooth and solid concrete ground with its strength more than 3000psi, tolerance of flatness less than 5mm and minimum thickness of 200mm. In addition, newly built concrete ground must undergo more than 28days' cure and reinforcement.

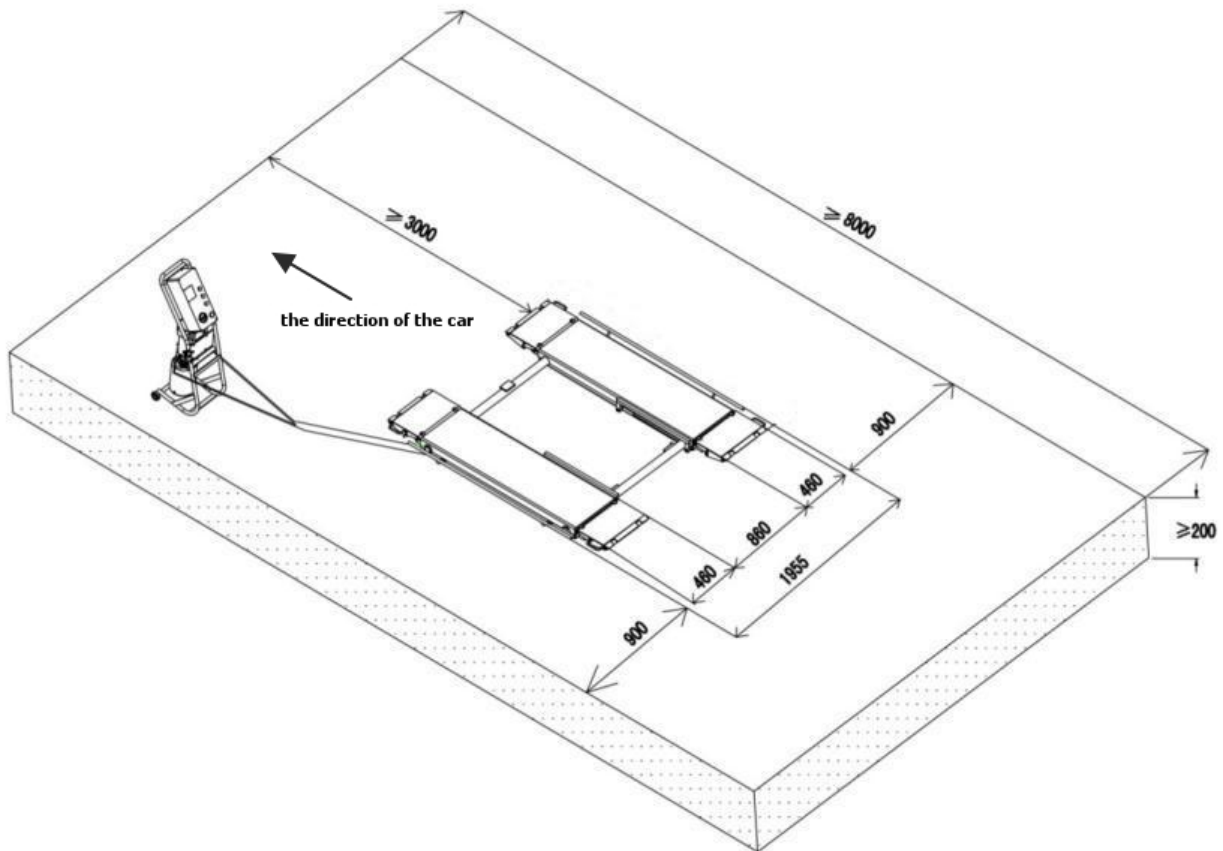

3.2 Precautions for installation

- 3.2.1 Joints of oil hose must be firmly connected in order to avoid leakage.
- 3.2.2 All bolts should be firmly screwed up.
- 3.2.3 Do not place any vehicle on the lift in the case of trial running.

3.3 Installation

- 3.3.1 Remove machine and pump station from the packing box, then drag them to specified place
- 3.3.2 Install the two feet protection fenders on the machine, as shown in the figure below.

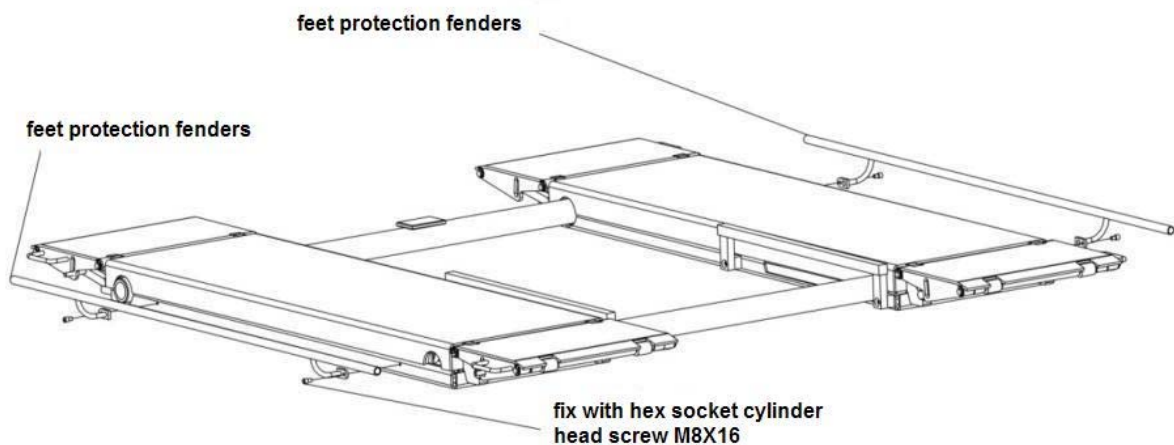

3.3.3 Identify the pipe and wires, as shown in the figure below.

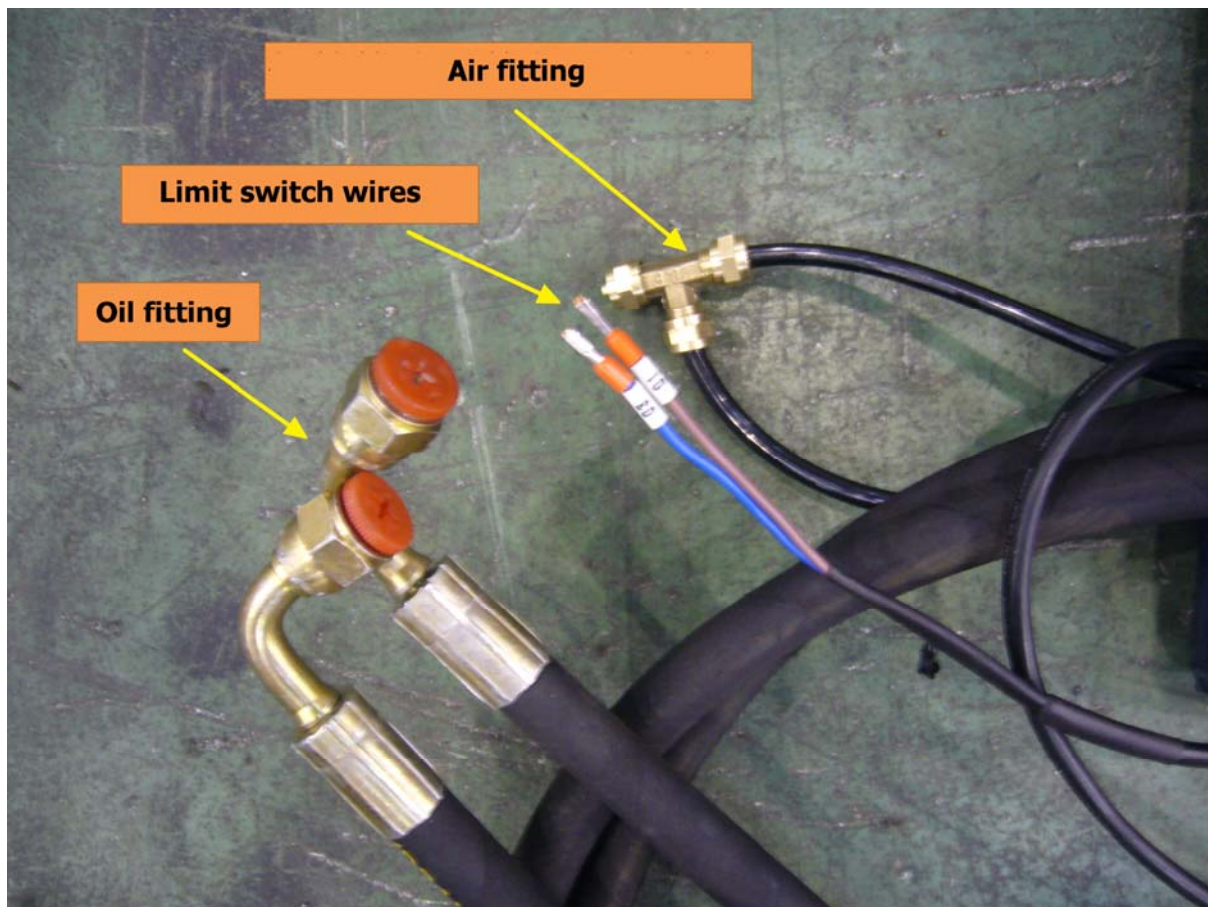

3.3.4 Connect two pieces of tubing to pumping stations, each side has 1 port, two pieces of tubing can be freely arranged on either side. As shown in the figure below.



3.3.5 Connect the limit switch wiring to the electrical box inside, as shown in the figure below: connect 01 wiring with 01 connecting column, connect 03 wiring with 03 connecting column

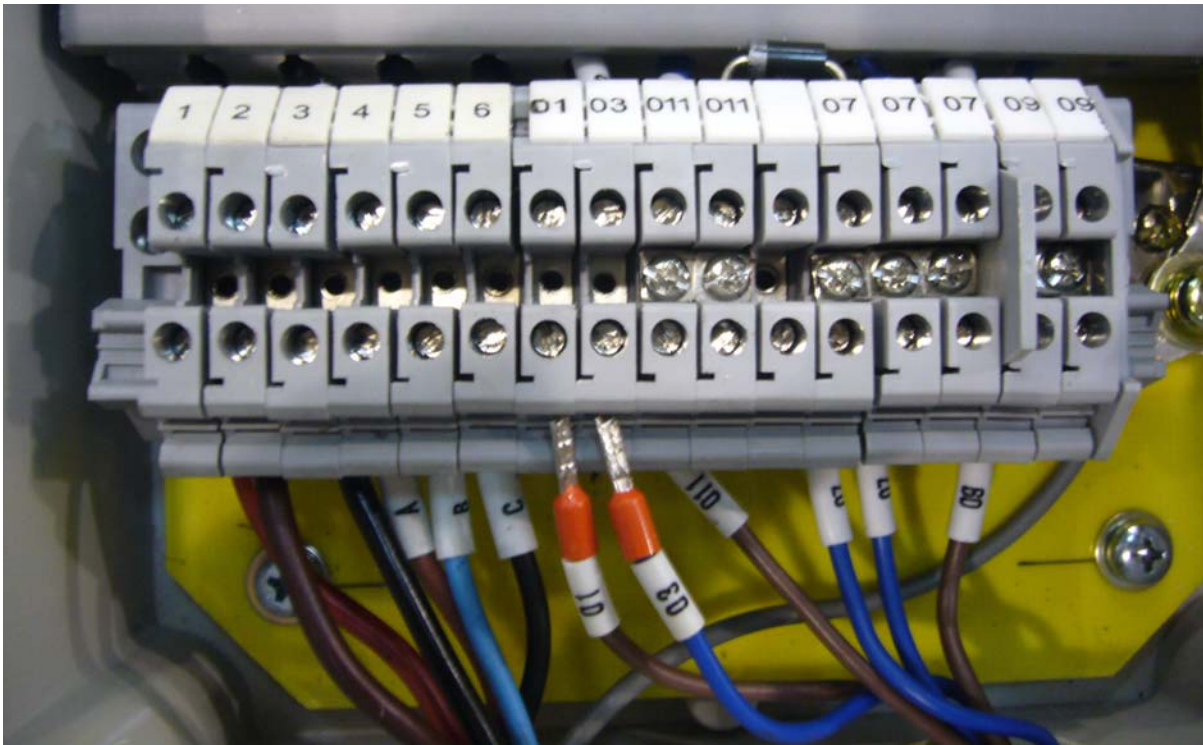

3.3.6 Connect the power supply plug in accordance with the electrical schematic diagram, then connect the compress air (the range of air pressure is between 1.0 and 1.5 kg/cm²) to air inlet of pump station oil-water separator, and then connect security lock pipe to the air outlet of pneumatic solenoid valve of pumping station.

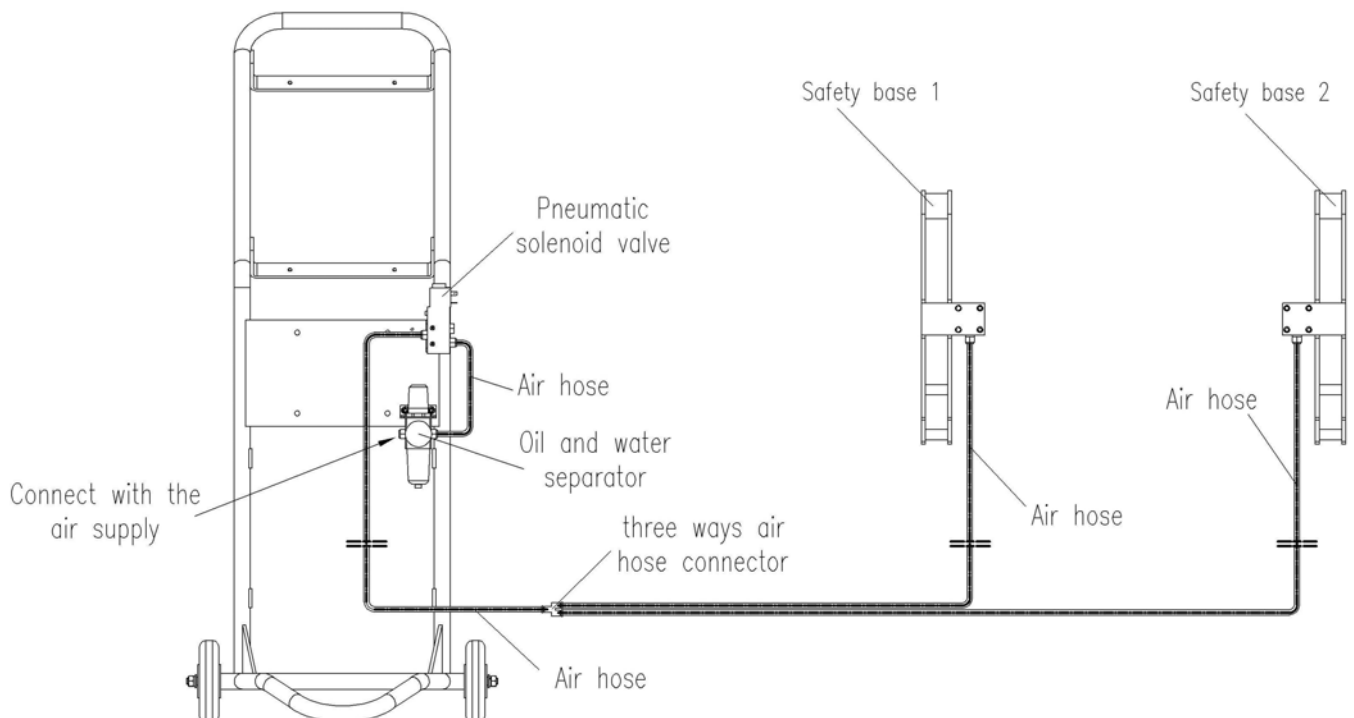

3.3.7 Connect the external power cord, and the power supply is connected.

3.3.8 Fill oil tank with hydraulic oil.

Inject enough 46# anti-wear hydraulic oil in oil tank, the distance between oil level and the top of oil tank should be in the range which is between 10 and 30 mm (stock rod which is on oil drum cove measures distance)

3.4 After the installation, check the following items:

- a. oil tubing be connected properly
- b. electrical parts be connected correctly
- c. no oil leaking in the valve of the pump station

OPERATION INSTRUCTIONS

4.1 Precautions

4.1.1 Check all the joints of oil hose. Only when there is no leakage, the lift can start work.

4.1.2 The lift, if its safety device malfunctions, shall not be used.

4.1.3 The machine shall not lift or lower an automobile if its center of gravity is not positioned midway of the rising platforms.

4.1.4 Operators and other personnel concerned should stand in a safety area during lifting and lowering process.

4.1.5 When platforms being raised to the desired height, switch off the power at once to prevent any wrong operation done by unconcerned people.

4.1.6 Make sure the safety locks of the lift are engaged before start working under the vehicle and no people under the vehicle during lifting and lowering process.

4.2 Descriptions of control box



4.3 Operation instructions

Raise the lift:

1. Make sure that you have read and understood the operation manual before operation.
2. Drive and park the vehicle midway between two platforms.
3. Place the four rubber pads under the prop-points of the vehicle and ensure car's gravity have fallen on the rubber pads.
4. Press the UP button on the control box until rubber pads have touched the prop-points of vehicle
5. Keep on pressing the UP button to lift the vehicle a bit higher from the ground and check again if the vehicle is in a safe position.
6. Having raised the vehicle to the required height, press the "lock" button to make the mechanical safety lock be engaged and then press the "emergency stop" and check again the stability of the vehicle before performing maintenance or repair work.

Lower the lift:

1. Open the emergency stop switch.
2. Press and hold DOWN button, the platform will raise a certain height, in order to open the insurance part, then the platform begin to descend.
3. The machine is equipped with safety warning device, it's normal to hear alarm voice throughout the descending process.
4. Drive away the car when platform be lowed to the minimum height.
5. Shut off the power.

Move the lift:

1. The lift platform rises around 500mm, install movable parts as shown in the figure below.

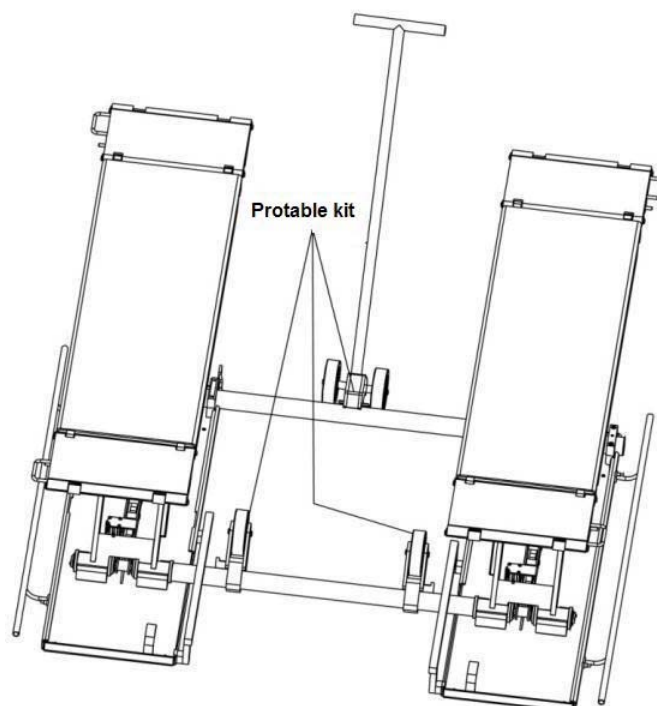

2. Minimize the height of lift platform.

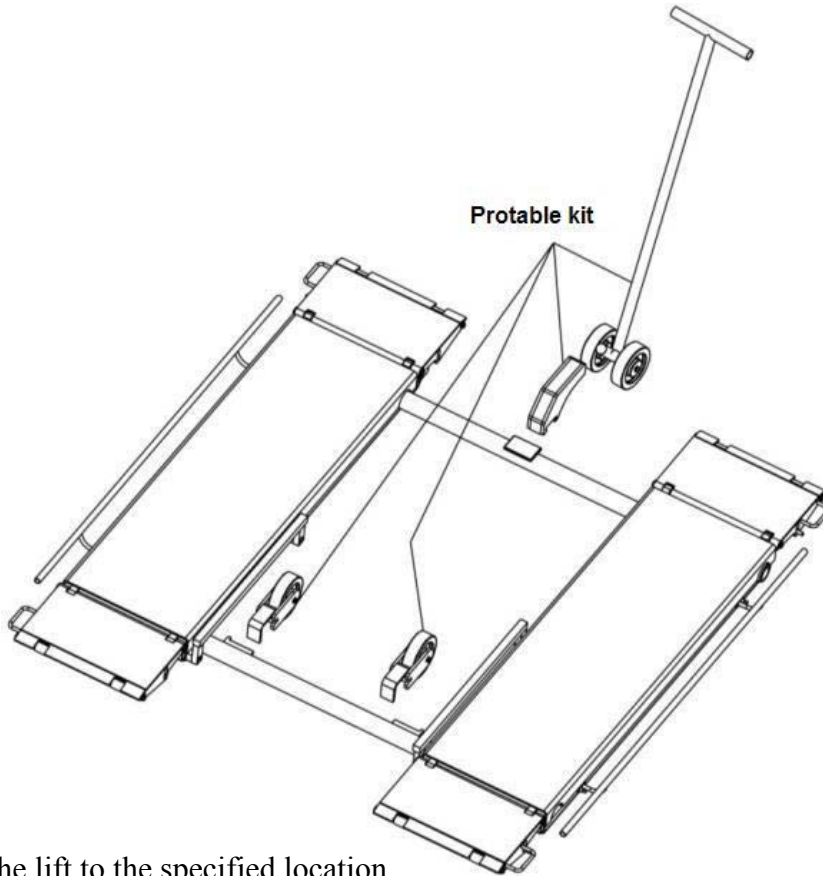

3. Move the lift to the specified location.

TROUBLE SHOOTING

ATTENTION: If the trouble could not be fixed by yourself, please do not hesitate to contact us for help .We will offer our service at the earliest time we can. By the way, your troubles will be judged and solved much faster if you could provide us more details or pictures of the trouble.

TROUBLES	CAUSE	SOLUTION
Motor does not run and will not raise	The motor is burnt	Replace it
	The wire connection is loose	Check and make a good connection
	Fuse is burned	Replace it
Motor runs but will not raise	The motor run reversely	Check the wire connection
	Oil level is too low	Add oil
	The relief valve is damaged	Fix or replace it
	The oil hose became loose or dropped off	Tighten it
Raising too slow	Oil level is too low	Add oil
	The overflow valve is not adjusted to the right position	Adjust it
	The lift is overloaded	Check the weight of the vehicle
	The oil filter is jammed	Clean or replace it
	The seal of the cylinder is abraded	Replace the seal
Platforms go down slowly after being raised	The oil hose leaks	Check or replace it
	Electrical unloading valve leaks	Clean or replace it
	The single valve leaks	Clean or replace it
	The oil cylinder is not tightened	Replace the seal
Lowering too slow	The hydraulic oil is dirty	Change the oil
	The oil hose jammed	Replace it
	Lowering restrictive valve is turned too low	Turn lowering restrictive valve up
Safety lock cannot be opened	The air pressure regulating valve is closed or too low	Adjust air pressure to 5kg/cm ²
	The Solenoid air valve is damaged	Replace it

MAINTENANCE

Easy and low cost routine maintenance can ensure the lift work normally and safely. You may choose the frequency of routine maintenance by consulting your lift's working conditions and time.

The following parts need to be lubricated:

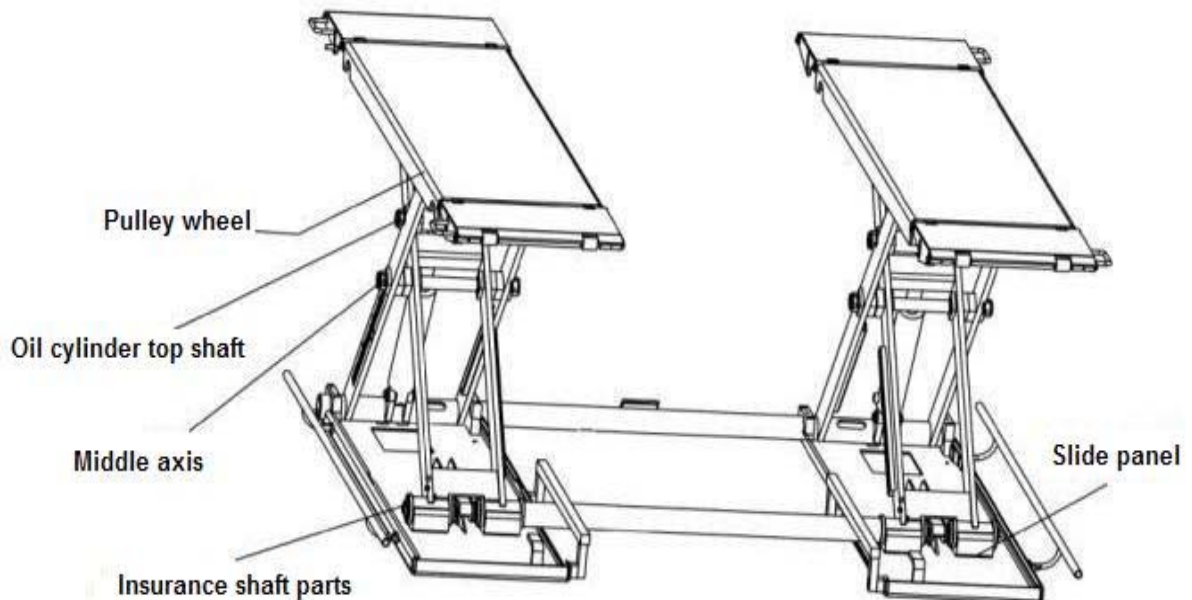

6.1 Daily checking items before operation

The user must perform daily check. Daily check of safety system is very important – the discovery of device failure before action could save your time and prevent you from great loss, injury or casualty.

- This machine should be constantly wiped and clean up ,and keep it clean. Before wiping, cut the power, ensure security.
- Check whether oil hose well connected. No leakage is allowed.
- Check the electric connections. Make sure all connections are in good condition.
- Check if safety teeth and safety block matched well or not.

6.2 Weekly checking items

- Check the flexibility of moving parts, and lubricate all pivot pins.
- Check whether the expansion bolts well anchored.
- Check the working conditions of safety parts.
- Check the amount of oil left in the oil tank. Oil is enough if the carriage can be raised to highest position. Otherwise, oil is insufficient.

6.3 Monthly checking items

- Check whether the expansion bolts well anchored.
- Check the tightness of the hydraulic system and screw firm the joints if it leaks.
- Check the lubrication and abrasion circumstance of moving parts.

6.4 Yearly checking items

- Check the lubrication and abrasion circumstance of moving parts.
- Empty the oil tank and check the quality of hydraulic oil.
- Wash and clean the oil filter.

6.5 Every three years or more than 5,000 routine maintenance items

- Replace the pin, bearings, tubing connector components.

ATTENTION: Strict maintenance of the machine according to the above requirements, the machine will keep work normally, and prevent accidents occurring to a large extent at the same time.

Annex

Annex 1, Packing List of the whole lift

- 1# platform
- 2# packaging wooden box of electric parts (including the following parts)

S/N	Name	Spec	Qty	Note
1	Cart parts	QJYJ30-ZW.8.1	1	
2	The control box	QJYJ30-ZW.14	1	Put the electrical box in the cart
3	Thin rubber mat	QJYJ020-02	4	
4	File		1	Including user's manual and certificate of approval
5	Wheel parts	QJYJ30-ZW.13	2	
6	Handle parts	QJYJ30-ZW.12.1	1	
7	Universal wheel fixing seat	QJYJ30-ZW.12.2	1	Fitted together
8	Handle seat	QJYJ30-ZW.12.3	1	
9	Universal wheel parts	QJYJ30-ZW.12.4	1	
10	Handle fixed axis	QJYJ30-ZW.12-01	1	Packed in one
11	Torsional spring latch	QJY245DS.9-06	2	
12	Flat gasket	GB97.1	2	
13	M8X16 Socket head screw	GB70.1	4	

Annex2, Overall diagram

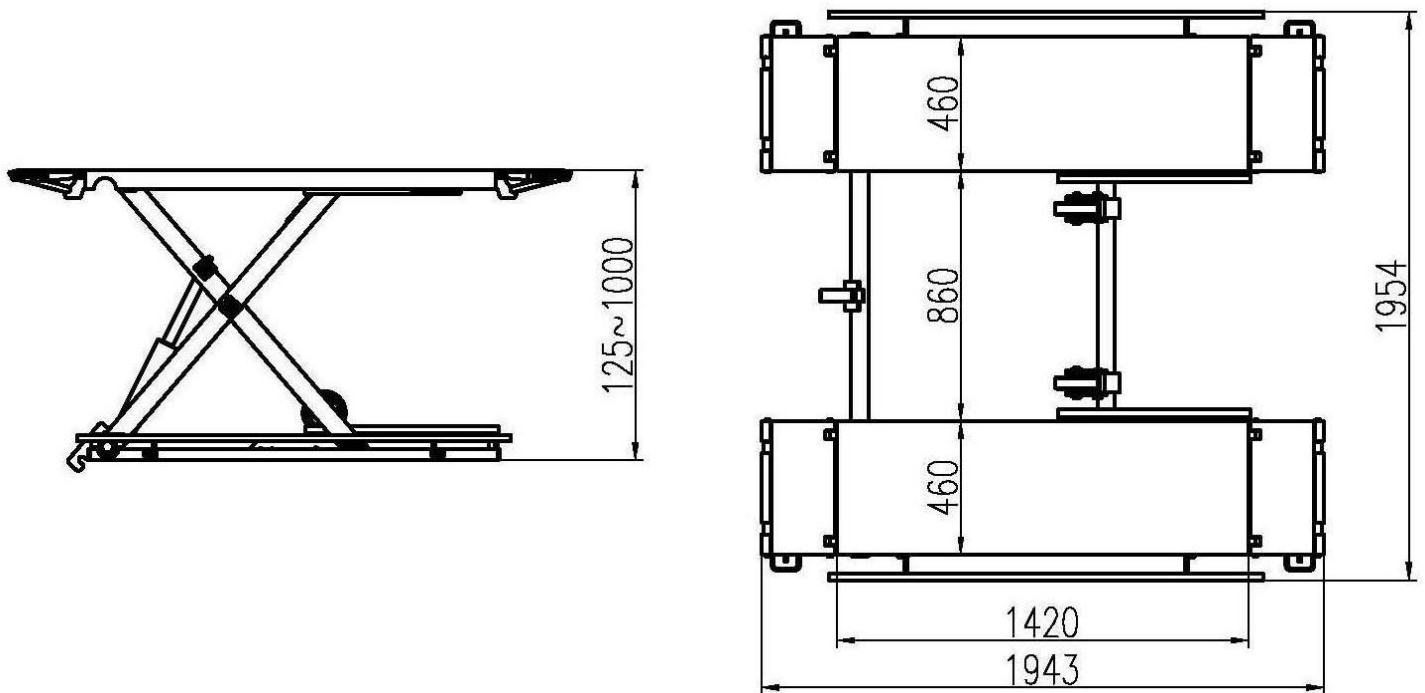

Annex 3, Hydraulic working system

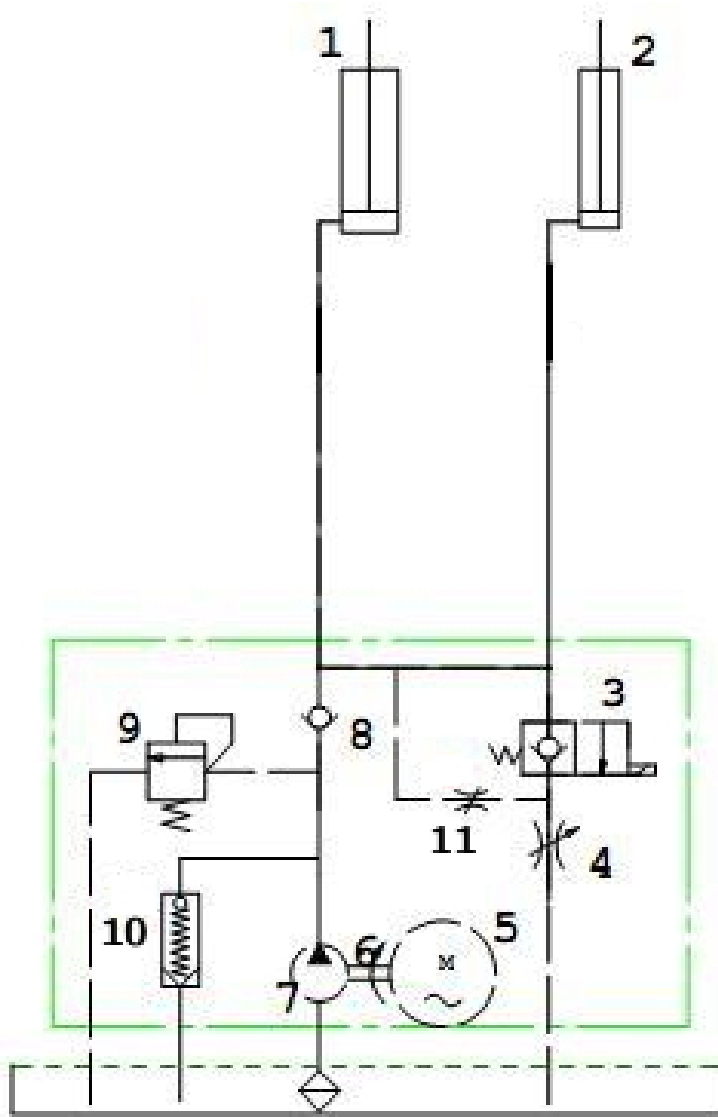

- 1、 Primary cylinder
- 2、 Secondary cylinder
- 3、 Electric magnet release valve
- 4、 Lowering throttle valve
- 5、 Power unit
- 6、 Coupling
- 7、 Gear pump
- 8、 One way valve
- 9、 Over-overflowing valve
- 10、 Cushion valve
- 11、 Emergent unloading valve

Annex4, Wiring diagram

Single-phase (220V)

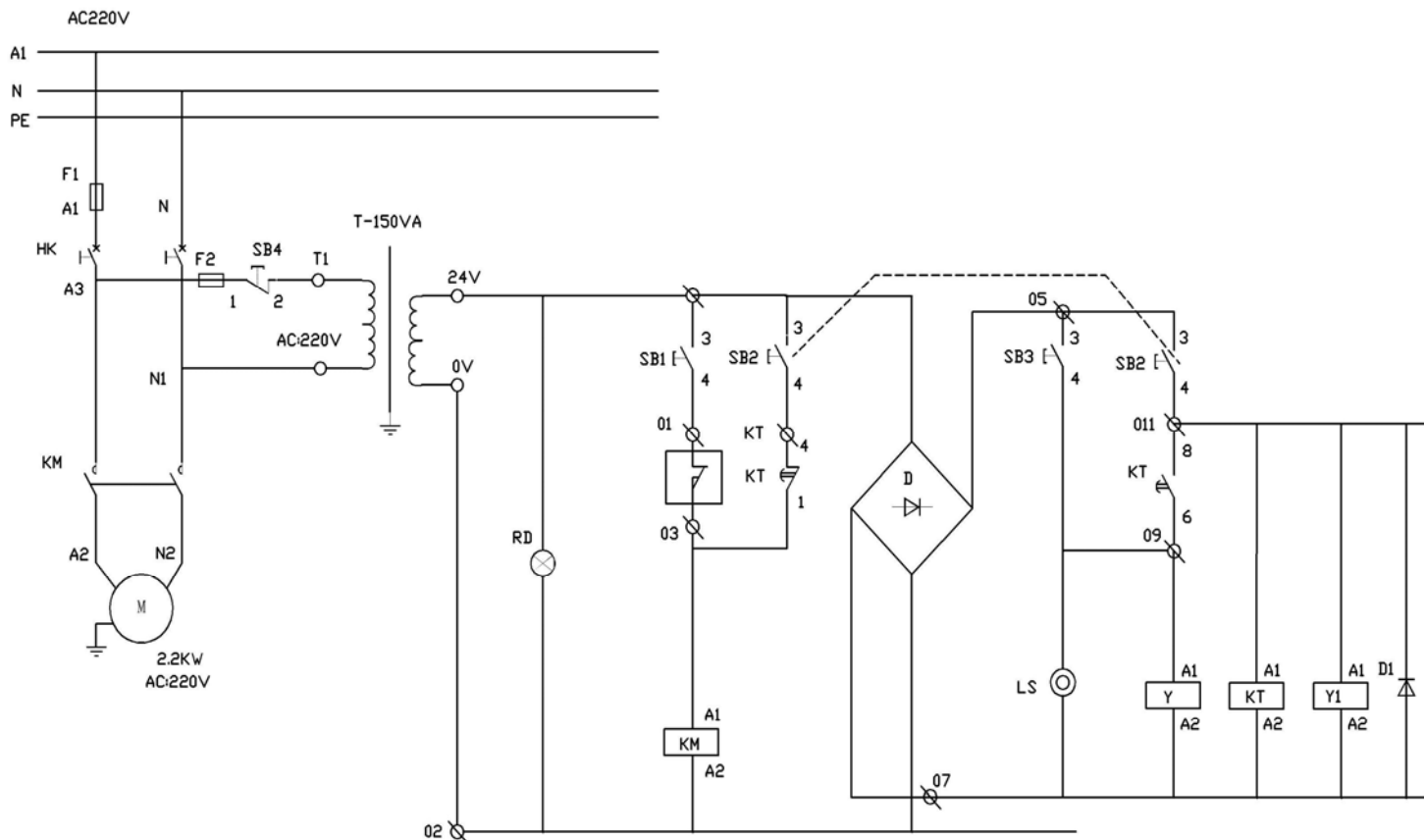

SB1~3--button

KM--contactor B16 AC:24V

T--transformers
AC: 220V/24V-26V

D--bridge rectifiers

LS--buzzer

Y, YA1--electromagnet
M--motor

HK--YMW26-20/3

SB4--STOP button

KT--DC:24V time relay
RD--lights

Three-phase (380V)

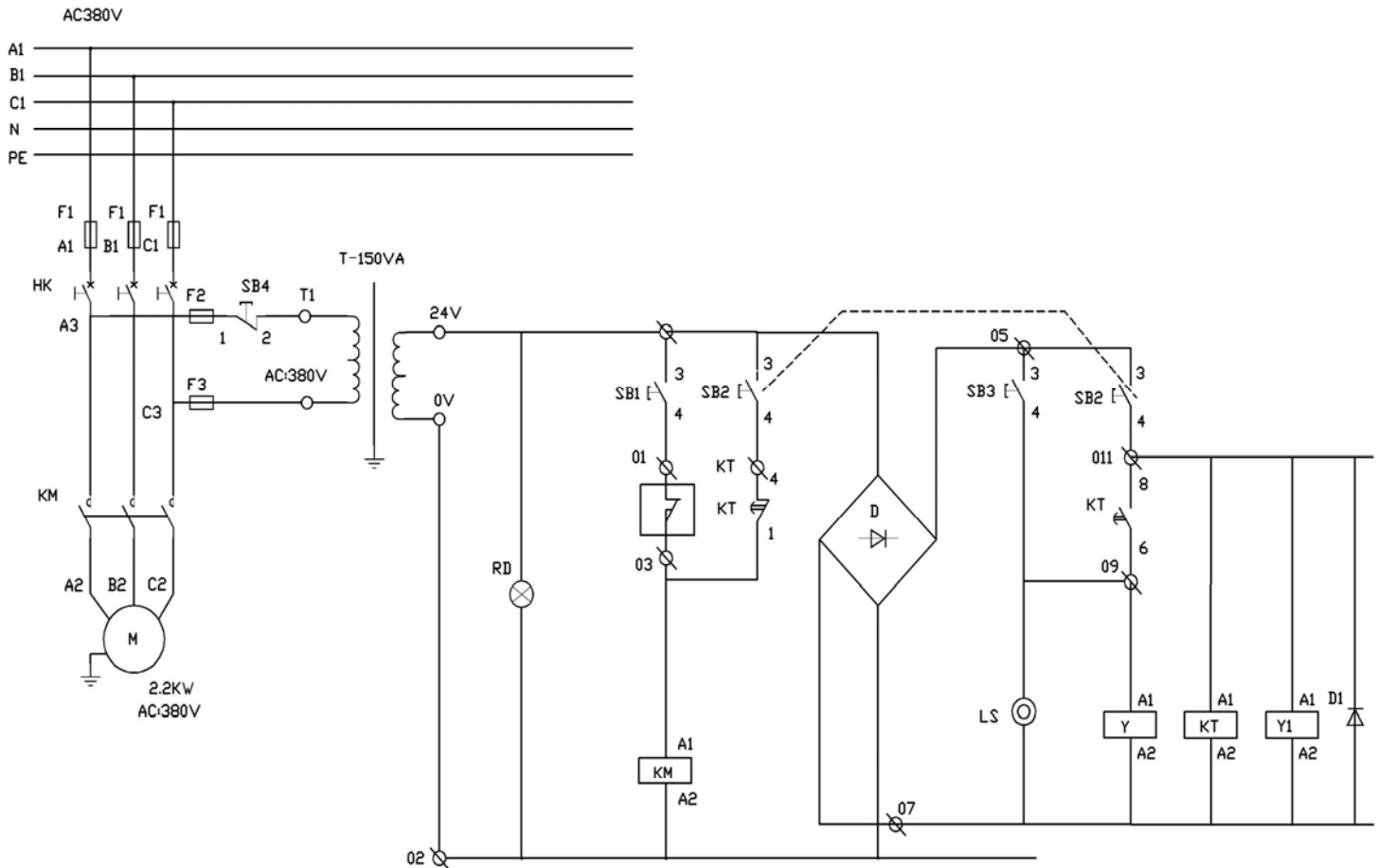

SB1~3--button

KM--contactor B16 AC: 24V

T--transformers

AC: 380V/24V-26V

D--bridge rectifiers

LS--buzzer

Y, YA1--electromagnet

M--motor

HK--YMW26-20/3

SB4--STOP button

KT-DC: 24V time relay



RD--lights

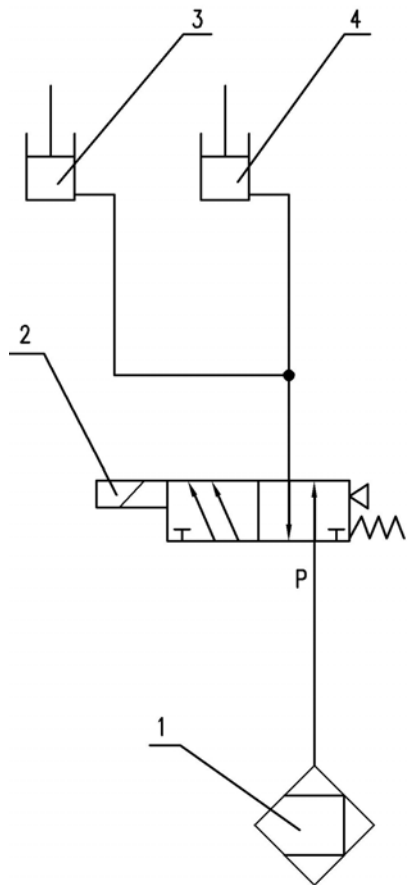





Annex5, Diagram for air supply connection





- 1. Air cleaner
- 2. Solenoid Directional Valve
- 3. Driving cylinder locking
- 4. Assistant cylinder locking

Annex 7, Spare parts list

S/N	Name	Spec	Unit	Qty/ set	Pictures
1	Power switch	YMW26GS-32/04 (220V) YMW26GS-20/04 (380V)	Pcs	1	
2	Button	YW1B-M1E20W	Pcs	1	
3	Button	YW1B-M1E10Y	Pcs	2	Same outlook as item2

S/N	Name	Spec	Unit	Qty/set	Pictures
4	Alarm lamp	AD115-22/DM	Pcs	1	
5	Power indicator	AD16-22D/S,AC DC24V	Pcs	1	
6	transformer	BK150,input 0-200-220-240V output 0-24-26V BK150,input 0-380-400-415V output 0-24-26V	Pcs	1	
7	AC contactor	TRC2-32/AC24-11 (220V) TRC2-18/AC24-11 (380V)	Pcs	1	
8	Time relay	JSZ6-2 24VDC 5S	Pcs	1	
9	Fuse wire	RT14-20 32A (220V)	Pcs	1	
		RT14-20 16A (380V)		3	
10	Fuse wire	RT14-20 2A (220V)	Pcs	1	Same outlook as item9
		RT14-20 2A (380V)		2	
11	Emergency stop button	LA135-01MXS/20B9 (R)	Pcs	1	

S/N	Name	Spec	Unit	Qty/s et	Pictures
12	Bridge rectifier	QL-3510	Pcs	1	
13	Diode	IN5408	Pcs	1	
14	Thermal relay	TRR2-10/17.5-30	Pcs	1	
15	Pneumatic valve	3V210-08	Pcs	1	

Annex 7, Separated drawings for the lift

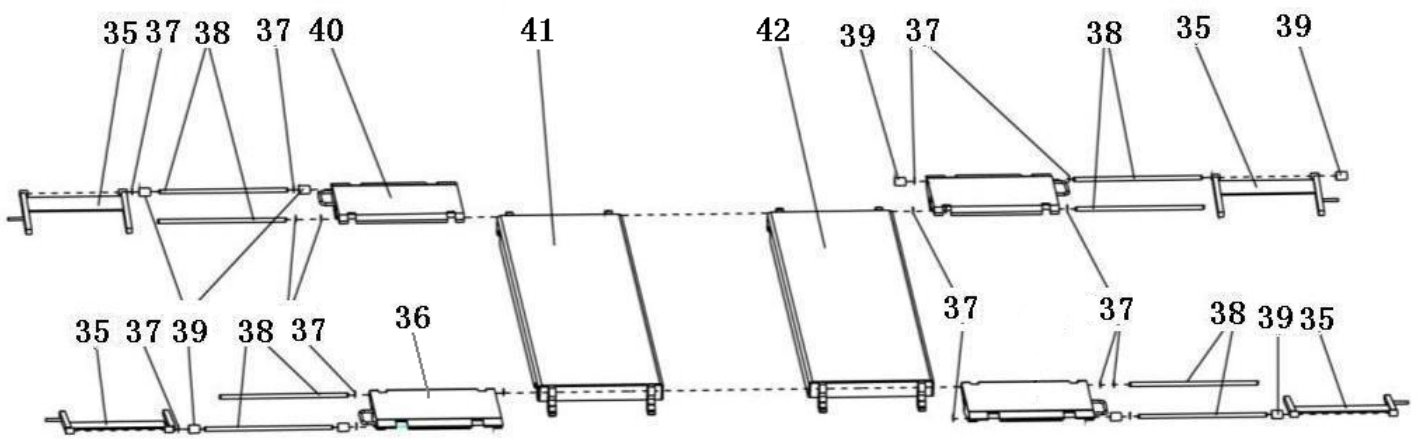
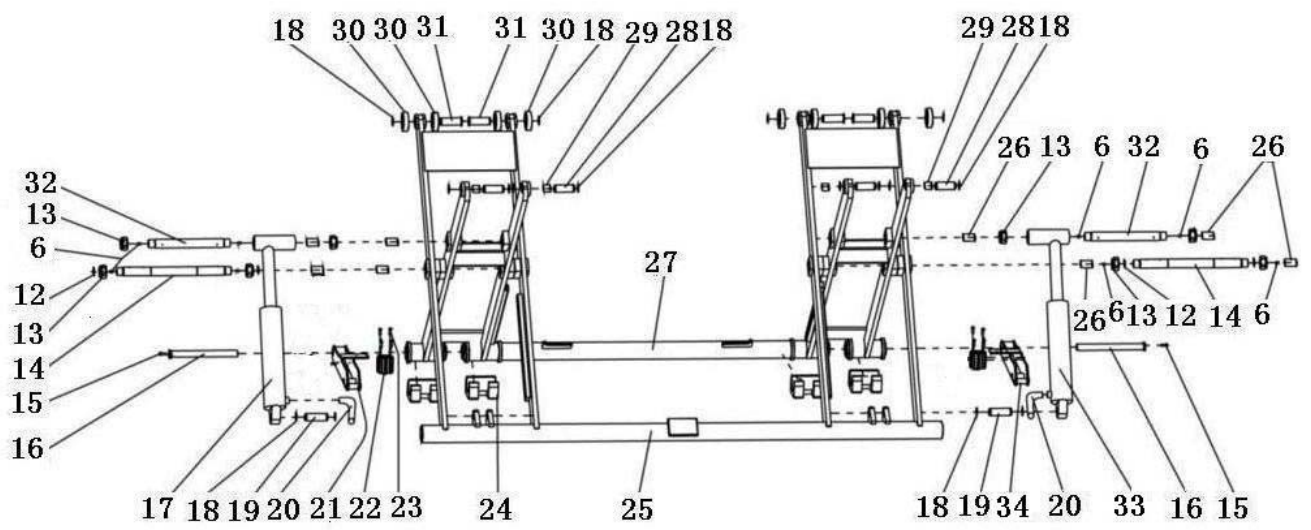
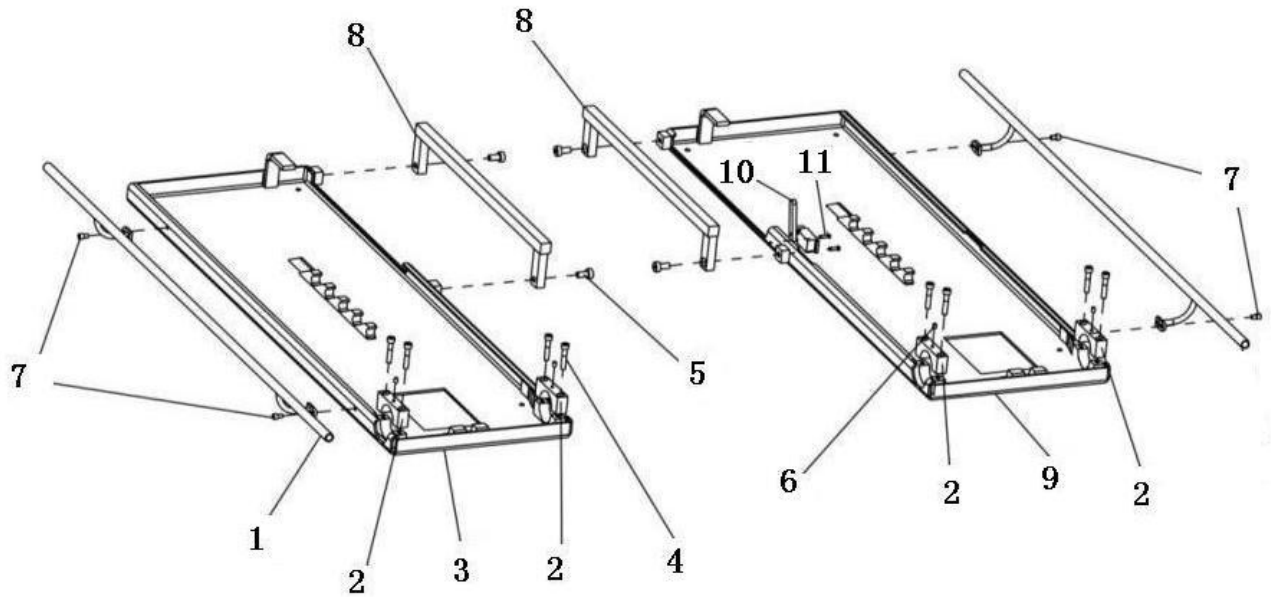

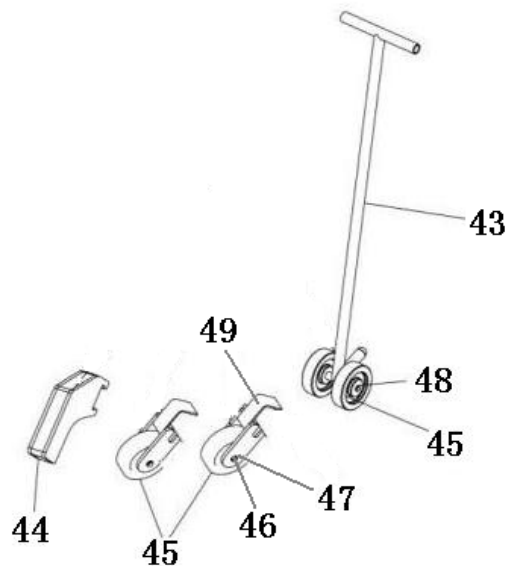

Product exploded diagram list

序号	图号	名称	数量
1	QJYJ30-ZW.11	Fence parts	2
2	QJYJ30-ZW-06	Fixed rod block	4
3	QJYJ30-ZW.5	Base parts 1	1
4	GB70.1	Socket head screw M10X50	8
5	GB70.1	Socket head screw M12X20	4
6	GB1155	Oil cup Φ6	12
7	GB70.1	Socket head screw M8X16	4
8	QJYJ30-ZW.9	Connecting rod	2
9	QJYJ30-ZW.6	Base parts 2	1
10	ME-8104	Travel limit switch	1
11	GB818	Cross recessed pan head screw M5X16	1
12	GB894.1	Axis check ring Φ30	4
13	GB889.1	Lock nut M27	8
14	QJYJ30-ZW-01	Medial axis	2
15	GB70.1	Socket head screw M6X16	2
16	QJYJ30-ZW.10	Insurance axis parts	2
17	QJYJ30-ZW.8-01	Oil cylinder parts 1	1
18	GB894.1	Axis check ring 25	16
19	QJYJ30-ZW-03	Cylinder fixed axis	2
20	QJY4040-XW.5-06	Tubing joint	2
21	QJYJ30-ZW.7.1	Insurance frame 1	1
22	QJYJ30-ZW.7-01	Air cylinder	2
23	GB70.1	Socket head screw M6X20	8
24	QJYJ30-ZW-05	Nylon slider	4
25	QJYJ30-ZW.3.1	Fixed rod parts	1

序号	图号	名称	数量
26	SF-2	Bush 3035	12
27	QJYJ30-ZW.4.1.	Sliding bar parts	1
28	QJYJ30-ZW-04	Platform fixed axis	4
29	SF-2	Bush 2520	4
30	QJYJ30-ZW.3-01	Pulley	8
31	QJYJ30-ZW.3-02	Pulley axis	4
32	QJYJ30-ZW-02	Cylinder head axis	2
33	QJYJ30-ZW.8-02	Oil cylinder parts 2	1
34	QJYJ30-ZW.7.2	Insurance holder 2	1
35	QJYJ30-ZW.1.4	Support rod parts	4
36	QJYJ30-ZW.1.3	Extend board parts 2	2
37	GB894.1	Axis check ring 15	16
38	QJYJ30-ZW.1-01	Extend board fixed axis	8
39	QJYJ30-ZW.1-02	Extend board roller	8
40	QJYJ30-ZW.1.2	Extend board part 1	2
41	QJYJ30-ZW.1.1	platform panel parts 1	1
42	QJYJ30-ZW.2.1	platform panel parts 2	1
43	QJYJ30-ZW.12.1	Moveable parts	1
44	QJYJ30-ZW-08	Moveable part connection block	1
45	QJYJ30-ZW.12-01	Moveable roller	4
46	QJYJ30-ZW.13-01	Wheel frame axis	2
47	GB97.1	Flat washer 20	6
48	GB91	Split pinΦ3.2X36	6
49	QJYJ30-ZW.13.1	Wheel frame parts	2