

BEFCO®

Operator's Manual

BABY-HOP

Pull Type Fertilizer Spreader

103-130, 106-130

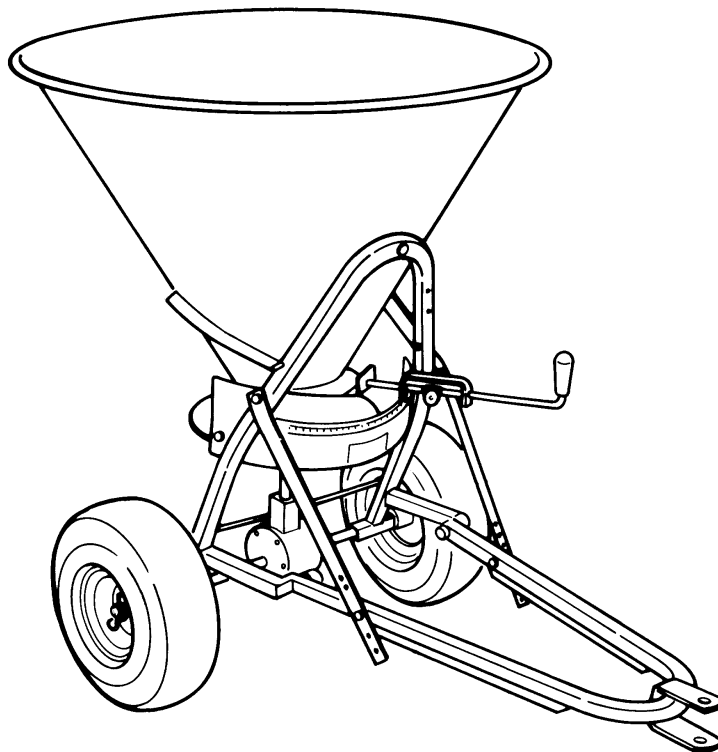

The operator's manual is a technical service guide and must always accompany the machine .

Manual 960-134B
Edition: October 2008

SAFETY

Take note! This safety alert symbol found throughout this manual is used to call your attention to instructions involving your personal safety and the safety of others. Failure to follow these instructions can result in injury or death.



*This symbol means:
ATTENTION!
BECOME ALERT!
YOUR SAFETY IS INVOLVED!*

Signal Words

Note the use of the signal words DANGER, WARNING and CAUTION with the safety messages. The appropriate signal words for each have been selected using the following guidelines:



DANGER: Indicates an imminently hazardous situation that, if not avoided, will result in death or serious injury.



WARNING: Indicates a potentially hazardous situation that, if not avoided, could result in death or serious injury, and includes hazards that are exposed when guards are removed. It may also be used to alert against unsafe practices.



CAUTION: Indicates a potentially hazardous situation that, if not avoided, may result in minor or moderate injury.

INDEX

1 - GENERAL INFORMATION	4
1.01 - General	4
1.02 - Model and Serial Number ID	4
1.03 - Assembly Instructions for Models 103 & 106	5
2 - SAFETY PRECAUTIONS	8
2.01 - Preparation	8
2.02 - Starting and Stopping	9
2.03 - Messages and Signs	9
3 - OPERATION	11
3.01 - Operational Safety	11
3.02 - Setup	12
3.03 - Pre-Operational Check	13
3.04 - Attaching to the Tractor	13
3.05 - Start Up	13
3.06 - Operating Techniques	14
3.07 - Uneven Terrain	16
4 - MAINTENANCE	17
4.01 - Maintenance Safety	17
4.02 - Service	18
4.03 - Transport	18
5 - REPAIR PROCEDURES	22
5.01 - Suggested Spare Parts	22
5.02 - Storage	22
6 - TROUBLESHOOTING	23
7 - PRE-DELIVERY CHECKLIST	24
8 - WARRANTY	25
PARTS MANUAL	29

1 - GENERAL INFORMATION

Thank you and congratulations for having chosen our implement. Your new fertilizer spreader is a technologically advanced machine constructed of high quality, sturdy components that will fulfill your working expectations.

Read this manual carefully. It will instruct you on how to operate and service your fertilizer spreader safely and correctly. Failure to do so could result in personal injury and/or equipment damage.

1.01 - General



CAUTION: Unless otherwise specified, all hardware is metric. Use only metric tools on metric hardware. Other tools that do not fit properly can slip and cause injury.



CAUTION: Right hand and left hand sides of the implement are determined by facing in the direction the implement will travel when going forward (see fig. 3).

1.02 - Model and Serial Number ID

Attached to the frame is an ID plate showing the model and serial number. Record your implement model and serial number in the space provided below. Your dealer needs this information to give you prompt, efficient service when you order parts.

BEFCO	1781 S. Wesleyan Blvd. — P.O. Box 6036 Rocky Mount, N.C. 27802 — U.S.A. Tel: 1.252.977.9920 Fax: 1.252.977.9718
MODEL:	<input type="text"/>
SERIAL:	<input type="text"/>
VERSION:	<input type="text"/>

Carefully read the Warranty section¹, detailing coverage and limitations of this warranty. **Warranty** is provided for customers who operate and maintain their equipment as

¹ See Chapter 8 - Warranty.

described in this manual. Warranty registration is accomplished by the dealer by completing and forwarding the **Warranty Registration** form to the Company, along with a copy of the dealer's invoice. It is in your best interest to insure that this has been done.

Warranty does not cover the following:

1. Cleaning, transporting, mailing and service call charges.
2. Normal wear items such as tires, bearings, etc.
3. Depreciation or damage caused by normal wear, accidents, improper maintenance, improper protection or improper use.
4. The use of non-original spare parts and accessories.

Your Authorized Company Dealer has genuine parts in stock. Only these approved replacement parts should be used.

This limited warranty covers defective material and workmanship. The cost of normal maintenance or repairs for accidents or improper use and related labor will be borne by the owner.

1.03 - Assembly Instructions for Models 103 & 106

NOTE: All hardware needed for assembly will be found in the hardware bag or on the machine.

Each unit is shipped with a hardware bag that consists of the following:		
Description	Model 103-130 Qty.	Model 106-130 Qty.
Stirrer guard (#3, fig. 2)	1	1
Guard (#14, fig. 2)	1	1
Shutter lever (#19, fig. 2)	1	1
Spreader disc (#46, fig. 2)	1	1
Mobile shutter (#48, fig. 2)	1	1
Air tire (#25 & 56, fig. 2)	2	2
Bolt bag contains the following:		
Stirrer (#4, fig. 2)	1	1
Threaded bushing (#7, fig. 2)	1	1
Cover (#60, fig. 2)	1	1
Carriage bolt M8X25 (#50, fig. 2)	2	2
Carriage bolt M8X40 (#8, fig. 2)	1	1
Bolt M8X16 (#16, fig. 2)	2	2
Bolt M8X40 (#15, fig. 2)	6	6
Bolt M6X30 (#5, fig. 2)	1	1
Bolt M6X45 (#26, fig. 2)	1	1
Nut M30 (#47, fig. 2)	1	1
Nut M8 (#10, fig. 2)	11	11
Lock nut M6 (#6, fig. 2)	2	2
Lock washer Ø8 (#59, fig. 2)	3	3
Flat washer Ø6 (#29, fig. 2)	4	4
Flat washer Ø8 (#9, fig. 2)	8	8
Flat washer Ø8 large band (#27, fig. 2)	3	3
Flat washer Ø20 (#31, fig. 2)	2	2
Shim Ø28 (#62, fig. 2)	2	2
Cotter pin Ø5 (#43, fig. 2)	1	1
Cotter pin Ø4 (#45, fig. 2)	2	2

NOTE: Assembly will be easier if all parts are loosely assembled before tightening the hardware.



CAUTION: Stand clear of bands when cutting as they could be under sufficient tension to cause them to fly loose. Take care in removing bands and wire. They often have extremely sharp edges and cut very easily.

To assemble the spreader do the following:

1. Locate the hopper (**see #2, fig. 2**), the mobile shutter (**#48, fig. 2**), the threaded bushing (**#7, fig. 2**) and the M30 nut (**#47, fig. 2**). Slide the threaded bushing (**#7, fig. 2**) through the bottom hole of the hopper (**#2, fig. 2**) and fasten the mobile shutter (**#48, fig. 2**) to it with the M30 nut (**#47, fig. 2**).
2. Fasten the guard (**#14, fig. 2**) onto the frame (**#11, fig. 2**) using the M8x16 bolts (**#16, fig. 2**), the Ø8 washers (**#9, fig. 2**) and M8 nuts (**#10, fig. 2**).
3. Slide the spreader disc (**#46, fig. 2**) and the hopper assembly over the outgoing shaft (**#44, fig. 2**) and use the M8x40 carriage bolt (**#8, fig. 2**), Ø8 large band washer (**#27, fig. 2**) and M8 nut (**#10, fig. 2**) to fasten the hopper to the frame (**#11, fig. 2**). Pin the spreader disc to the shaft with the cotter pin (**#43, fig. 2**).
4. Place stirrer (**#4, fig. 2**) and cover (**#60, fig. 2**) over the outgoing shaft (**#44, fig. 2**) and secure them using the M6x30 bolt (**#5, fig. 2**), the Ø6 washers (**#29, fig. 2**) and the M6 lock nut (**#6, fig. 2**).
5. Place the stirrer guard (**#3, fig. 2**) inside the hopper (**#2, fig. 2**) and fasten with the two M8x20 carriage bolts (**#50, fig. 2**), Ø8 large band washers (**#27, fig. 2**) and M8 nuts (**#10, fig. 2**) that connect the sides of the frame (**#11, fig. 2**) to the hopper (**#2, fig. 2**).
6. Slide the shutter lever (**#19, fig. 2**) into the slot of the mobile shutter (**#48, fig. 2**) and fasten to the guard (**#14, fig. 2**) with the adjustment knob (**#20, fig. 2**) and Ø8 washer (**#58, fig. 2**).
7. Assemble the wheels (**#25 & 56, fig. 2**) making sure that the side of the wheel hubs that has the hole is facing the inside of the spreader. Place the Ø28 shims (**#62, fig. 2**) on each side of the axle (**#28, fig. 2**) before inserting the wheels. Assemble the wheels (**#25 & 56, fig. 2**) on the axle (**#28, fig. 2**), followed by the Ø20 washers (**#31, fig. 2**) and secure them in place with the cotter pins (**#45, fig. 2**). On the right wheel (**#25, fig. 2**), insert the M6x45 bolt (**#26, fig. 2**) through the hole in the hub and axle, place the Ø6 washers (**#29, fig. 2**) on each side of the hub and secure it in place with the M6 lock nut (**#6, fig. 2**).
8. The towing hitch (**#51, fig. 2**) is attached to the frame with two hitch adjustment plates, one right (**#17, fig. 2**) and one left (**#18, fig. 2**). Attach the upper end of the hitch adjustment plate to the hole in the square tubing of the frame (**#11, fig. 2**) using the M8x40 bolts (**#15, fig. 2**). Use the M8x40 bolts (**#15, fig. 2**), the Ø8 washers (**#9, fig. 2**) and the M8 nuts (**#10, fig. 2**) to secure the lower end of the hitch adjustment plates (the one with the series of holes) to the towing hitch (**#51, fig. 2**). Select the hole which best fits the pulling units drawbar enabling the spreader to run parallel to the ground.

9. To attach hitch connection plates (#21 & #22, fig. 2), slide the round stock ends of these two plates through the tubes which are welded to the ends of the towing hitch (#51, fig. 2). Bolt the hitch connection plates (#21 & #22, fig. 2) to the outer end of the frame (#11, fig. 2) using M8x40 bolts (#15, fig. 2), Ø8 washers (#9, fig. 2) and M8 nuts (#10, fig. 2). Make sure that the two hitch connection plates (#22, fig. 2) are angled upwards and the stock ends are pointed inwards after assembly.
10. Tighten all hardware.

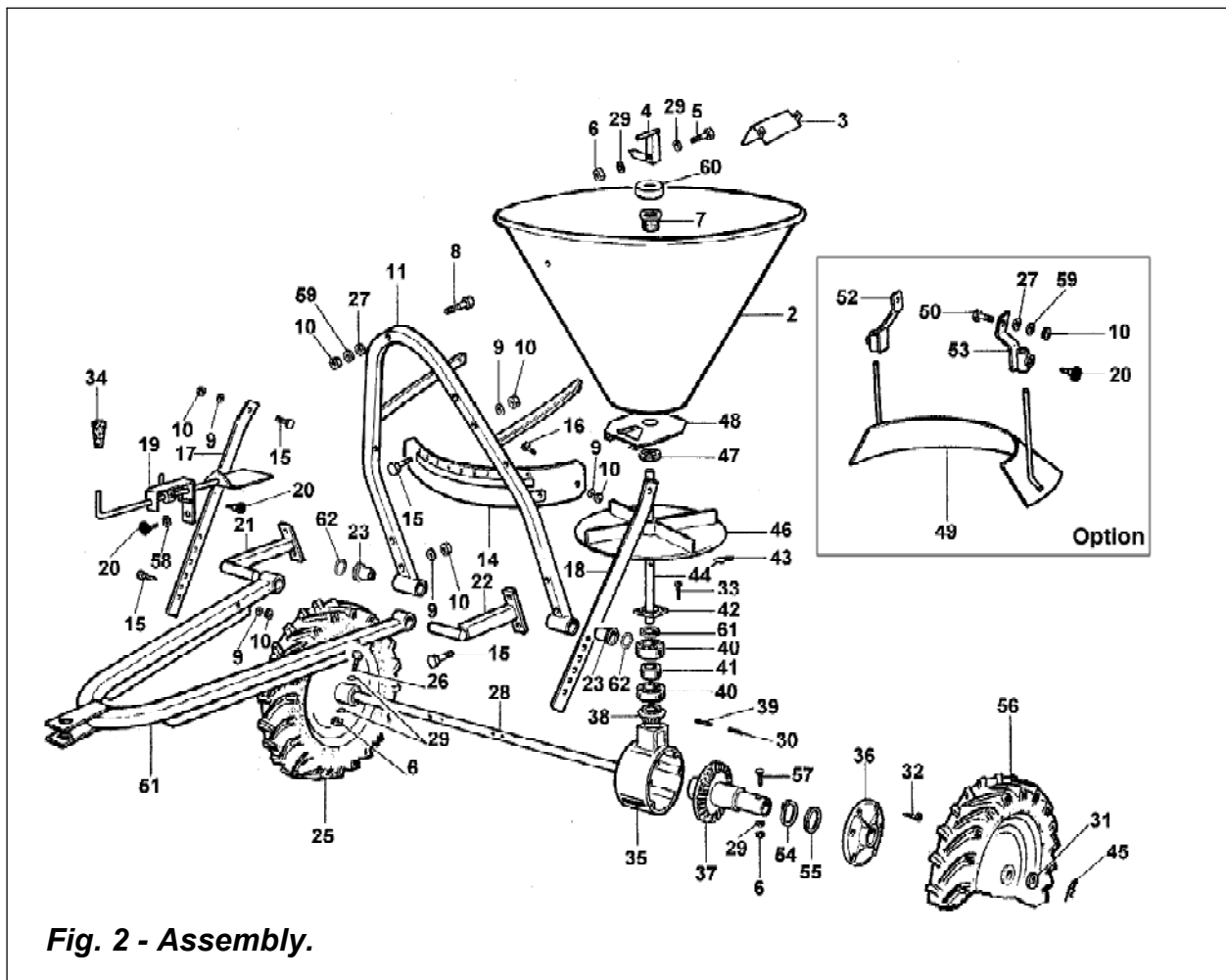

Fig. 2 - Assembly.

2 - SAFETY PRECAUTIONS

Safety is the primary concern in the design and manufacture of our products. Unfortunately our efforts to provide safe equipment can be wiped out by a single careless act of an operator.

In addition to the design and configuration of equipment, hazard control and accident prevention are dependent upon the awareness, concern, prudence and proper training of personnel involved in the operation, transport, maintenance and storage of equipment.

It is the operator's responsibility to read and understand all safety and operating instructions in the manual and to follow these.

Allow only properly trained personnel to operate the fertilizer spreader. Working with unfamiliar equipment can lead to careless injuries. Read this manual, and the manual for your tractor, before assembly or operating, to acquaint yourself with the machines. It is the spreader owner's responsibility, if this machine is used by any person other than yourself, is loaned or rented, to make certain that the operator, prior to operating, reads and understands the operator's manuals and is instructed in safe and proper use.

2.01 - Preparation



1. Before operating equipment read and understand the operator's manual and the safety signs (**see fig. 3**).
2. Thoroughly inspect the implement before initial operation to assure that all packaging materials, i.e., wires, bands, and tape have been removed.
3. Personal protection equipment including hard hat, safety glasses, safety shoes, and gloves are recommended during assembly, installation, operation, adjustment, maintaining and/or repairing the implement.
4. Operate the fertilizer spreader only with a tractor equipped with an approved Roll-Over-Protective-System (ROPS). Always wear your seat belt. Serious injury or even death could result from falling off the tractor.
5. Clear area of stones, branches or other debris that might be thrown, causing injury or damage.
6. Operate only in daylight or good artificial light.
7. Ensure fertilizer spreader is properly mounted, adjusted and in good operating condition.
8. Ensure that all safety shielding and safety signs are properly installed and in good condition.

2.02 - Starting and Stopping



1. Be sure that no one is near the tractor prior to startup or while it is working.
2. Be sure the tractor is in "Neutral" before starting engine.
3. Know how to stop the tractor quickly in case of an emergency.
4. After striking an obstacle, shut the tractor down and thoroughly inspect for damage before restarting.

2.03 - Messages and Signs



1. Read and adhere to all safety and operating decals on this machine (**see fig. 3**).
2. Before dismounting tractor: Stop engine, set brake and remove the key of unattended equipment.
3. Keep guards and shields in place and in good condition.
4. Do not use with bystanders in area.
5. Allow no riders on tractor or fertilizer spreader.
6. Allow moving parts to stop before repair.
7. Securely support fertilizer spreader before working underneath.

Additional warning and operating decals are available at no extra charge. Please specify model and serial number when ordering.

Fig. 3 - Safety decals; replace immediately if damaged.

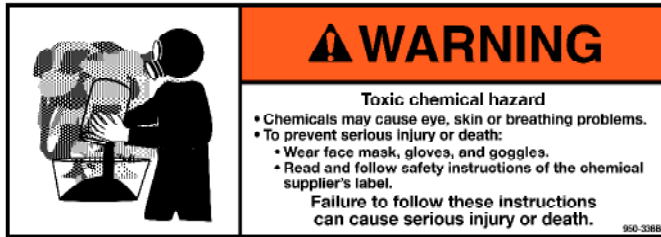

⚠ WARNING

Toxic chemical hazard

- Chemicals may cause eye, skin or breathing problems.
- To prevent serious injury or death:
 - Wear face mask, gloves, and goggles.
 - Read and follow safety instructions of the chemical supplier's label.

Failure to follow these instructions can cause serious injury or death.

950-338B



⚠ CAUTION

To avoid serious injury:

- Read Operator's Manual before operating, servicing or repairing equipment. Follow all safety rules and instructions. (Manuals are available from your selling dealer.)
- Never allow riders.
- Keep bystanders away from equipment during operation.
- Operate from tractor seat only.
- Keep all shields in place and in good condition.
- Lower equipment to ground, stop engine, remove key and set brake before dismounting tractor.
- Never allow children or untrained persons to operate equipment.
- If equipped, parking stands must be functional, kept in good repair, and stored on the unit. Park and store on a hard, level surface.



950-417B

right side

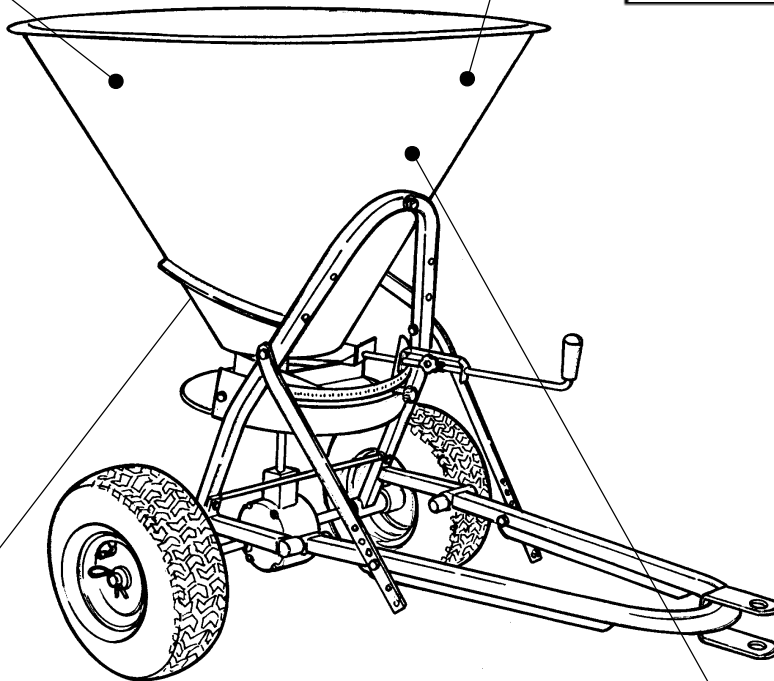
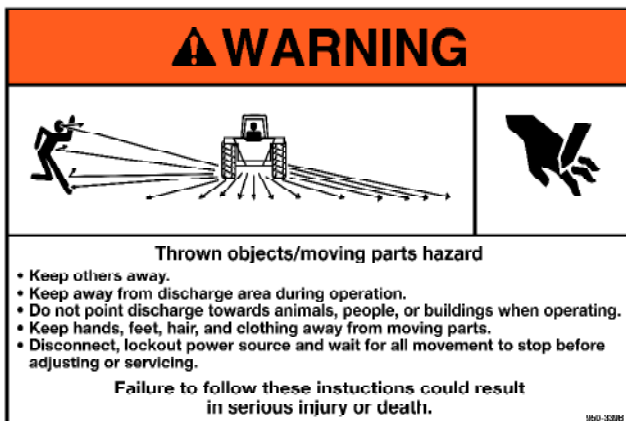
left side

⚠ WARNING

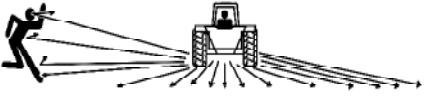
Thrown objects/moving parts hazard

- Keep others away.
- Keep away from discharge area during operation.
- Do not point discharge towards animals, people, or buildings when operating.
- Keep hands, feet, hair, and clothing away from moving parts.
- Disconnect, lockout power source and wait for all movement to stop before adjusting or servicing.

Failure to follow these instructions could result in serious injury or death.

950-338B



⚠ CAUTION

Avoid Injury:

- Do not load hopper until it has been properly attached to the transport unit.
- Do not disconnect spreader until material has been removed from unit.

060-341D

3 - OPERATION

The Baby-Hop ground driven fertilizer spreaders are designed and sized for lawn tractors, ATV's or other equipment without PTO.

Ideal for parks, gardens, greenhouses, nurseries, athletic fields, etc. The Baby-Hop may also be used as a salt spreader for snow or ice covered roads during winter months.

Spreaders can be used for broadcast spreading or may be used to spread prevalently to the left or to the right with a simple adjustment.

The rotating spreader disc is ground driven by the pneumatic tires which are attached to a drive axle that runs through a sealed gearbox (with tempered high carbon steel gears).

The Baby-Hop should be used to distribute granular fertilizers, seeds, sand and small granular salt. It is not designed for use with powder type material.

An optional deflector shield is available to regulate swath spread.

3.01 - Operational Safety



CAUTION: Our spreaders are designed considering safety as the most important target and are the safest available in today's market. Unfortunately, human carelessness can override the safety features built into our machines. Injury prevention and work safety, aside from the features on our spreaders, are very much due to the responsible use of the equipment. It must always be operated prudently following with great care, the safety instructions laid out in this manual.



1. The use of this equipment is subject to certain hazards which cannot be prevented by mechanical means or product design. All operators of this equipment must read and understand this entire manual, paying particular attention to safety and operating instructions, prior to using.
2. Do not operate the tractor and spreader when you are tired, sick or when using medication.
3. Keep all helpers and bystanders at least 50 yards from a spreader. Only properly trained people should operate this machine.
4. Accidents are most likely to occur with machines that are loaned or rented to someone who has not read the operator's manual and is not familiar with a spreader.
5. Always stop the tractor, set brake, shut off the tractor engine, remove the ignition key, and allow spreader moving parts to come to a complete stop before dismounting tractor. Never leave equipment unattended with the tractor running.

6. Never place hands or feet into hopper with tractor engine running or before you are sure all motion has stopped. Stay clear of all moving parts.
7. Do not allow riders on the spreader or tractor at any time. There is no safe place for riders.
8. Before backing up, look behind carefully.
9. Install and secure all guards and shields before starting or operating.
10. Keep hands, feet, hair and clothing away from moving parts.
11. Never operate tractor and spreader under trees with low hanging limbs. Operators can be knocked off the tractor and then run over.
12. Stop spreader immediately upon striking an obstruction. Turn engine off, remove key, inspect and repair any damage before resuming operation.
13. Stay alert for holes, rocks and roots in the terrain and other hidden hazards. Keep away from drop-offs.
14. Use extreme care and maintain minimum ground speed when transporting on hillside, over rough ground and when operating close to ditches or fences. Be careful when turning sharp corners.
15. Reduce speed on slopes and sharp turns to minimize tipping or loss of control. Be careful when changing directions on slopes. Do not start or stop suddenly on slopes. Avoid operation on steep slopes.
16. Inspect the entire machine periodically². Look for loose fasteners, worn or broken parts, and leaky or loose fittings.
17. Pass diagonally through sharp dips and avoid sharp drops to prevent "hanging up" tractor and spreader.
18. Avoid sudden starts and stops while traveling up or downhill.
19. Always operate down slopes; never across the face. Avoid operation on steep slopes. Slow down on sharp turns and slopes to prevent tipping and/or loss of control.
20. All remote control devices (cables, ropes, rods, flexible lines, etc.) should be positioned in a way to prevent maneuvers which could lead to accidents or damages.
21. Before loading the fertilizer in the hopper read carefully the instructions printed on the fertilizer canvas bag concerning the precautions to be taken in case of toxicity or corrosivity of the product. Before loading switch off the engine and remove the ignition key.
22. Load hopper with product only after the spreader has been properly attached to the tractor.

3.02 - Setup

Notice to dealer: Pre-delivery setup and service including lubrication is the responsibility of the authorized dealer. It is up to him to assure that the machine is in perfect condition and ready to be used. It is his responsibility to ensure that the customer is aware of all safety aspects and operational procedures for the spreader. He must also fill out the Pre-Delivery Checklist³ prior to delivering the spreader.

² See Chapter 4 - Maintenance.

³ See Chapter 7 - Pre-Delivery Checklist.

3.03 - Pre-Operational Check

Check each of the following, carefully, prior to engaging the equipment:

1. No wrappings or foreign objects are around the spreader.
2. All hardware is tight.
3. All safety shields and guards are in place and tightly attached.
4. No people or animals are in the work area.



DANGER: Shut off the tractor and remove the key before making adjustments, servicing or cleaning the machine.

3.04 - Attaching to the Tractor



CAUTION: Always ensure that the tractor tire pressure is correct according to the tractor operator's manual.



DANGER: Failure to ensure a secure coupling of the implement to the tractor can cause injury and damage to the implement or tractor.

To attach the spreader to the tractor do the following:

1. Slip the tractor drawbar hitch into the towing hitch. Secure the spreader hitch into the tractor drawbar with the pin.
2. Adjust the towing hitch (**see #51, fig. 2**) so that the spreading disc (**see #46, fig. 2**) is horizontal when operating.

3.05 - Start Up



CAUTION: Load hopper with product only after the spreader has been properly attached to the tractor.



WARNING: Chemicals may cause eye, skin or breathing problems. Always wear a face mask, gloves and goggles when filling hopper. Refer to chemical manufacturer's label for specific safety information.

Prior to start working do the following:

1. Make sure there are no obstructions.
2. Run machine under a no-load condition for a short while to assure that everything is functioning properly.
3. Adjust all settings for the desired quantity distribution and spread pattern.
4. Shift the transmission to a slow speed gear and start forward, increase the ground speed by shifting upward until the desired speed is obtained. Do not use in reverse unless absolutely necessary and only after careful observation of the area behind the spreader.



WARNING: Use a tractor with a cab and appropriate filters on the ventilation system or wear a breathing mask capable of filtering toxic powders to prevent inhalation of product.

Before starting to use, never forget that the **operator is responsible** for the following:

1. Safe and correct driving of the tractor and spreader.
2. To learn precise, safe operating procedures for both the tractor and the spreader.
3. To ensure all maintenance and lubrication has been performed on the spreader.
4. To have read and understood all safety aspects for the spreader in the operator's manual.
5. To have read and understood all safety decals on the spreader.
6. Checking the tractor tires for the proper pressure in accordance with the tractor operator's manual.
7. **Checking that all shields are on the machine and securely in place.**
8. Making sure the proper attire is worn. Avoiding loose fitting clothing which can become entangled. Wearing sturdy, tough-soled work shoes and protective equipment for eyes, hands, ears and head. Never operate tractor or implements in bare feet, sandals or sneakers.
9. Ensuring proper lighting is available, sunlight or good artificial lighting.

3.06 - Operating Techniques



DANGER: Never allow anyone within 50 yards of the spreader while the PTO is engaged. Product thrown from the spreader can cause serious injury or death.



DANGER: Never allow any person inside the hopper for any reason. Serious injury or death can result from someone becoming entangled in the agitator.

The quantity of material distributed per acre depends on the following factors:

1. Spreader ground speed.
2. Unit weight and size of the material to be spread.
3. Spreading width.
4. Position of the lever.

The working speed depends on ground conditions. Only a test run will enable you to gauge the optimal working speed for your conditions.

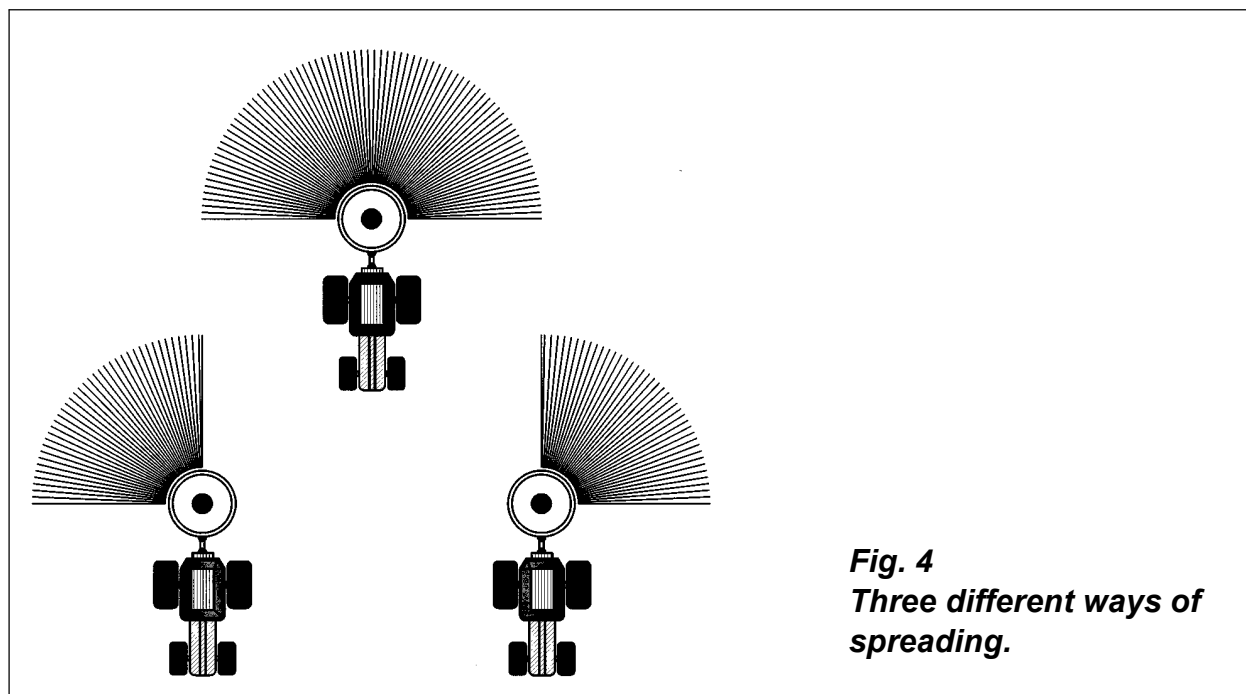

Fig. 4
Three different ways of spreading.

Spread adjustment

The Baby Hop's spreading is adjustable in three ways by:

1. Regulating the **spread pattern**.
2. Regulating the **amount of material to be spread**.
3. Regulating the **spreading width**.

To regulate the **spread pattern** slide (to the left or right) the lever (see #19, fig. 2) which is located under the hopper and runs through the slot in the disc shielding (see #14, fig. 2). This moves the spread pattern from 180° at position 0 (in the center), to either mostly 90° right with the lever shifted all the way to the left or mostly 90° left when shifted to the right completely (see fig. 4).

To regulate the **amount of material to be spread**, using the same lever as above (see #19, fig. 2), slide it in and out to regulate the size of opening at the bottom of the hopper. Use the scale located near the lever to gauge the size opening needed. Example: if it is determined that the appropriate opening desired is position #6, loosen the knob (see #20, fig. 2) so the blocking plate will slide. Push the lever in until the hole

is completely closed and move the blocking plate to position #6 and tighten the knob. To spread, pull the lever back until it stops in position #6.

To regulate the **spreading width**, ground speed is the most important factor, the faster the ground speed the further the material is thrown. An optional rear deflector (**see #49, fig. 2**) is available for additional regulation. Move the deflector up and down to change the spreading distance. The higher the position of the deflector the further the spread width, the lower the less distance the material travels.

In order to give a guide to the operator, **Table 3⁴** gives the amount of material distributed (lbs./1000 sq.ft) at two spreading widths (6.5 ft. and 13 ft.) versus the lever position.



CAUTION: For emergency reasons learn how to stop the tractor and spreader quickly.

3.07 - Uneven Terrain



WARNING: Be careful of roll-over when operating tractor and spreader over uneven ground.

The following precautions should always be observed when working on uneven terrain:

1. In extremely uneven terrain rear wheel weights, front tractor weights, and/or tire ballast should be used to improve stability.
2. Observe the type of terrain and develop a safe working pattern.
3. Whenever traction or stability is doubtful, first test drive over the terrain.
4. Operate the implement up and down steep slopes, not across slopes, to prevent the tractor from tipping. Avoid sudden stops and starts, and slow down before changing directions on a slope.
5. Pass diagonally through sharp dips and avoid sharp drops to prevent hanging up the tractor and implement.
6. Slow down on sharp turns and slopes to prevent tipping or loss of control.
7. Watch for holes, roots or other hidden objects. Do not use near the edge of a gully, ditch or stream bank.

⁴ See Table 3, page 21.

4 - MAINTENANCE



DANGER: Stop engine, lock parking brake and remove key before performing any service or maintenance.

Always use personal protection devices, such as a breathing mask capable of filtering toxic powders, safety glasses and gloves, when performing maintenance. Refer to chemical manufacturer's label for specific safety information.

Keep fingers out of slots to prevent injury.

4.01 - Maintenance Safety



1. Good maintenance is your responsibility.
2. Keep service area clean and dry. Be sure electrical outlets and tools are properly grounded. Use adequate light for the job at hand.
3. Make sure there is plenty of ventilation. Never operate the engine of the towing vehicle in a closed building. The exhaust fumes may cause asphyxiation.
4. Make no repair or adjustments with the tractor engine running. Before working on the machine, disengage the PTO, shut off the engine, set the brakes, and remove the ignition key.
5. Be certain all moving parts on attachment have come to a complete stop before attempting to perform maintenance.
6. Never work under equipment unless it is blocked securely.
7. Always use personal protection devices such as eye, hand and hearing protectors, when performing any service or maintenance.
8. Periodically tighten all bolts, nuts and screws and check that all cotter pins are properly installed to ensure unit is in a safe condition.
9. When completing a maintenance or service function, make sure all safety shields and devices are installed before placing unit in service.
10. Do not attempt to mount a tire unless you have the proper equipment and experience to do the job.
11. Inflating or servicing tires can be dangerous. Whenever possible, trained personnel should be called to service and/or mount tires.
12. After servicing, be sure all tools, parts and service equipment are removed.
13. Never replace hex bolts with less than grade five bolts unless otherwise specified, i.e. shear bolts⁵.

⁵ Refer to Table 1 - Torque Specifications, for head identification marking, page 20.

14. Where replacement parts are necessary for periodic maintenance and servicing, genuine replacement parts must be used to restore your equipment to original specifications. The company will not claim responsibility for use of unapproved parts and/or accessories and other damages as a result of their use.
15. Unauthorized modifications to the machine may impair the function and/or safety of the machine and reduce its life. If equipment has been altered in any way from original design, the manufacturer does not accept any liability for injury or warranty.

4.02 - Service

Before beginning work:

1. Apply a thick layer of grease to all exposed moving parts.
2. Apply a film of biodegradable oil in crevasses and corners in order to keep corrosive material from rusting areas that are difficult to clean.

After each use:

1. Be sure to thoroughly wash the machine without using excessive pressure especially on the moving parts. It is particularly important to wash the implement after using salt or fertilizer. This will help prevent the caustic chemicals in the salt and fertilizer from destroying the metal of the machine.
2. Carefully dry the machine.
3. Apply a thick layer of grease to all exposed moving parts.
4. Apply a film of biodegradable oil in crevasses and corners.

After seasonal use it is important to perform the following for prolonged storage:

1. Wash and dry the spreader carefully.
2. Inspect the spreader and replace worn or damaged parts. If corrosive material has eaten under the paint, clean off the area with a wire brush and touch-up with primer and paint.
3. Tighten all hardware.
4. Apply a thick layer of grease to all exposed moving parts.
5. Apply a film of biodegradable oil in crevasses and corners.
6. Cover the spreader from the elements in order to have it in perfect condition for the start of the next season.

NOTE: The gearbox has been filled with EP grade grease from the factory. The grease never needs replacing unless internal work is done to the gearbox.

4.03 - Transport









CAUTION: Do not tow tractor and spreader behind other vehicles. Use a properly equipped trailer with heavy tie-downs for towing operations.

Before transporting:

1. Always select a safe ground speed that is appropriate for the terrain.
2. Beware of traffic on public roads. Install a SMV (Slow Moving Vehicle) sign when traveling on roads or streets.
3. Reduce ground speed when turning and take care that the spreader does not strike obstacles such as trees, fences or buildings.

TABLE 1 - TORQUE SPECIFICATIONS

Metric (ISO) treaded bolts head marking	 Class 5.8	 Class 8.8	 Class 10.9	Inch (SAE) treaded bolts head marking	 Grade 2	 Grade 5	 Grade 8	Bolt size		Thread		N.m		ft-lb	
								mm	inch	mm	tpi				
M5	0.8	4	3	6	4	9	7	1/4"	20	7	5	11	8	16	12
M6	1	6	4	10	7	15	11	1/4"	28	8	6	13	10	19	14
M8	1.25	16	12	25	18	36	27	5/16"	18	15	11	24	17	33	25
M8	1	17	13	26	19	38	28	5/16"	24	17	13	26	19	37	27
M10	1.5	31	23	48	35	71	52	3/8"	16	27	20	42	31	59	44
M10	1.25	33	24	51	38	75	55	3/8"	24	31	23	47	35	67	49
M10	1	35	26	53	39	78	58	7/16"	14	43	32	67	49	95	70
M12	1.75	54	40	84	62	123	91	7/16"	20	48	36	75	55	106	78
M12	1.5	56	41	87	64	128	94	1/2"	13	66	48	102	75	144	106
M12	1.25	59	44	90	66	133	98	1/2"	20	75	55	115	85	163	120
M14	2	84	62	133	98	195	144	9/16"	12	95	70	147	109	208	154
M14	1.5	94	69	142	105	209	154	9/16"	18	106	79	164	121	232	171
M16	2	131	97	206	152	302	223	5/8"	11	132	97	203	150	287	212
M16	1.5	141	104	218	161	320	236	5/8"	18	149	110	230	170	325	240
M18	2.5	181	133	295	218	421	310	3/4"	10	233	172	361	266	509	376
M18	2	196	145	311	229	443	327	3/4"	16	261	192	403	297	569	420
M18	1.5	203	150	327	241	465	343	7/8"	9	226	167	582	430	822	606
M20	2.5	256	189	415	306	592	437	7/8"	14	249	184	642	473	906	668
M20	1.5	288	212	454	335	646	476	1"	8	339	250	873	644	1232	909
M22	2.5	344	254	567	418	807	595	1"	12	371	273	955	704	1348	995
M22	1.5	381	281	613	452	873	644	1-1/8"	7	480	354	1077	794	1746	1288
M24	3	444	327	714	526	1017	750	1-1/8"	12	539	397	1208	891	1958	1445
M24	2	488	360	769	567	1095	808	1-1/4"	7	677	500	1519	1120	2463	1817
M27	3	656	484	1050	774	1496	1103	1-1/4"	12	750	553	1682	1241	2728	2012
M27	2	719	530	1119	825	1594	1176	1-3/8"	6	888	655	1992	1469	3230	2382
M30	3.5	906	668	1420	1047	2033	1499	1-3/8"	12	1011	746	2268	1673	3677	2712
M30	2	1000	738	1600	1180	2250	1659	1-1/2"	6	1179	869	2643	1949	4286	3161
M36	4	1534	1131	2482	1830	3535	2607	1-1/2"	12	1326	978	2974	2194	4823	3557

When using lock washers with nuts, increase torque values by 5%

TABLE 2 - BABY HOP - TECHNICAL FEATURES

Series Baby-Hop						
Model	Hopper capacity	Carrying weight lbs.	Weight lbs.	Loading height	Width	Spreading width ft.
103-130	3.53 cu.ft.	226	62	39"	32"	3' - 20'
106-130	5.60 cu.ft.	362	84	44"	35"	3' - 20'

Optional equipment: The optional deflector shield (#49, fig. 2) is designed to reduce the spreading width so that the Baby-Hop can be used to spread salt on sidewalks, driveways, etc.

TABLE 3 - SWATH SPREADING PATTERNS (lbs./1000 sq.ft)

Lever position	Spreading width 6.5 feet		Spreading width 13 feet	
	2 mph	4 mph	2 mph	4 mph
1	6	4	3	2
2	12	6	6	3
3	19.5	10	10	5
4	28	14	14	7
5	37	18	19	9
6	46.5	23	23	11.5
7	56	28	28	14
8	65.5	33	33	16.5
9	77	39	38.5	19.5
10	-	44	-	22

5 - REPAIR PROCEDURES



CAUTION: All repair procedures must be done by authorized dealerships. It is not recommended that untrained individuals perform any repair work.

5.01 - Suggested Spare Parts

It is suggested that the following spare parts be kept on hand for the spreader at all times to prevent a minor problem from delaying work:

Description	Quantity
Spreader disc	1
Threaded bushing	1
Nylon bushing M21	2

5.02 - Storage

After seasonal use it is important to perform the following for prolonged storage:

1. Empty hopper of product before unhooking it from the tractor.
2. Wash and dry the spreader carefully.
3. Inspect the spreader and replace worn or damaged parts. If corrosive material has eaten under the paint, clean off the area with a wire brush and touch up with paint.
4. Tighten all hardware.
5. Grease or oil all areas indicated under Maintenance⁶.
6. Apply a thick layer of grease to all exposed moving parts.
7. Cover the spreader from the elements in order to have it in perfect condition for the start of the next season.
8. Do not permit children to play on or around the stored unit.
9. Do not park or store equipment where it will be exposed to livestock for long periods of time. Damage and livestock injury could result.
10. Make sure all parked machines are on a hard, level surface, and engage all safety devices.

⁶ See Chapter 4 - Maintenance.

6 - TROUBLESHOOTING



WARNING: Be sure tractor engine is off, parking brake is locked, and key is removed before making any adjustments.

PROBLEM	POSSIBLE CAUSE	SOLUTION
Non uniform spread pattern.	Opening lever not positioned correctly	Set lever and gate opening to the proper position (see Section 3.06 - Operating Techniques)
Spreader disc does not turn.	Drive wheel bolt missing or sheared. Spreader disc cotter pin missing or sheared. Broken ring or pinion gear.	Replace bolt. Replace cotter pin. Replace ring or pinion gear.
Narrow spread width.	Slow ground speed. Hopper too far backwards.	Increase ground speed. Position spreader so it runs level or inclined slightly forward toward the towing vehicle.

7 - PRE-DELIVERY CHECKLIST

To the dealer: Inspect the machine thoroughly after assembly to assure it is functioning properly before delivering it to the customer. The following checklist is a reminder of points to cover. Check off each item as it is found satisfactory or after proper adjustment is made.

- Gearbox oil level.
- Guards and shield properly fastened.
- Lubrication of grease fittings.
- All hardware properly tightened.
- All decals properly located and readable (**see fig. 3**).
- Blades properly installed, blade bolts and nuts tightened.
- Overall condition (touch up scratches, clean and polish).
- Test run, check for excessive vibration or overheating of bearings.
- Operator's Manual.

Review the Operator's Manual with the customer. Explain the following:

- Warranty.
- Safe operation and service.
- Correct machine installation and operation.
- Daily and periodic lubrication, maintenance and inspections.
- Troubleshooting.
- Operational procedures and storage.
- Parts and service.
- Fill out the Pre-Delivery Checklist and Warranty Registration form.
- Give customer the Operator's Manual and encourage the customer to read the manual carefully.

IMPORTANT: Warranty is not valid unless Pre-Delivery Checklist and Warranty Registration form in Operator's Manual is completed in detail and mailed to the Company.

Model Number: _____

Serial Number: _____

Delivery Date: _____

Dealer's Signature: _____

8 - WARRANTY

BEFCO's responsibility will be limited to substitution of the acknowledged defective merchandise to the same place of delivery as the previous one was supplied.

1. LIMITED WARRANTY

BEFCO, Inc. herein referred to as the Company, warrants its machines and related accessories, hereafter referred to as the Machine, to be free from defects in material and workmanship, for a period of twelve (12) months from the date of invoice to the first registered owner; this limited warranty does not apply to common wear items and excludes belts, shear pins, oil, grease, tires, tubes, hydraulic hoses, knives and PTO shafts.

Labor will be reimbursed at \$40.00 per hour based on BEFCO's time schedule.

Cost of transport to the servicing dealer is the responsibility of the customer.

Warranty coverage shall not be transferable from the first owner to any subsequent owner.

2. DISCLAIMER OF ALL OTHER WARRANTIES AND REMEDIES

Neither the Company nor any company affiliated with the Company makes any warranties, representations or promises, expressed or implied, as to the quality, performance or application of its products other than those set forth herein and does not make any implied warranty of merchantability or fitness.

The only remedies the purchaser has in connection with the breach, or performance of any warranty on the Company's Machine are those set forth herein. In no event will the dealer, the Company, or any company affiliated with the Company, be liable for:

- a. Injuries or damages of any kind or nature, direct, consequential or contingent to person or property.
- b. Any expenses incurred by the owner to repair, replace or rework any allegedly defective item.
- c. Any loss, cost, forfeiture or damages (including loss of profits; loss of crops; loss because of delay in field operations; any expenses or loss incurred for labor, supplies, substitute machine rental; liabilities of the owner to its customers or third persons; and all other consequential damages, losses, liabilities or damages for any other reasons) whether direct or indirect, and whether or not resulting from or contributed to by the default or negligence of the Company, its agents, employees and subcontractors which might be claimed as a result of the use or failure of the equipment delivered.

The Company's liability based on this limited warranty or any other applicable laws shall be limited to replacement or refund of the purchase price of the product.

The limited warranty extended herein gives you specific rights and you may also have other rights which vary from state to state. Neither the dealer nor the Company personnel has the authority to make any representation or to modify the terms and limitations of this warranty in any way.

Other than the limited warranty extended hereby there is no other expressed warranty in connection with the design, safety or use of any of the Company's products except as to title. All implied warranties are expressly disclaimed pursuant to the terms of this warranty.

3. CUSTOM WORK

If the Machine is used for commercial purposes such as custom work, the period warranted for the Machine is limited to six (6) months from the date of delivery to the first registered owner and does not cover any labor charges incurred.

4. RENTAL

If the Machine is used for rental purposes the period warranted for the Machine is limited to thirty (30) days from the date of delivery to the first registered owner and does not cover any labor charges incurred.

5. REGISTRATION

In order to qualify for coverage on this limited warranty, the product and name of the original purchaser must be registered with the Company by a completed Machine Pre-Delivery Checklist and Warranty Registration along with a copy of the dealer's invoice to the first registered owner to the Company within fourteen (14) days after the date of delivery to the original purchaser.

6. WARRANTY SERVICE

Warranty Service must be performed by a dealer authorized by BEFCO. If the warranty service requested is approved, the owner shall pay only for labor beyond the rate allowed, for overtime labor, and for any mileage charge for transporting the equipment to and from the dealer's shop. It is assumed that the dealer has the appropriate general and special tools to service the machine. Time required for replacement of knives, oil, grease and to remove excessive dirt from the Machine is not subject to reimbursement by the Company. The owner is required to clean the Machine before presenting it to the dealer for service work. The Machine must be delivered within thirty (30) days after failure date by the owner to the dealer to be eligible for warranty consideration.

7. UNAPPROVED SERVICE OR MODIFICATION

All obligations of the Company under this limited warranty shall be terminated if:

- a. Proper service and operation instructions as outlined in the Operator's Manual and on the instruction sticker on the Machine, are not followed.
- b. The Machine is modified or altered in any way not approved by the Company.
- c. The Company does not receive a copy of the dealers invoice to the first registered owner within fourteen (14) days from the date of delivery.
- d. The Company has not been paid in full, by the dealer, for the Machine.

8. ACCIDENTS AND NORMAL MAINTENANCE

This limited warranty covers defective material and workmanship. It does not cover depreciation or damage caused by normal wear, accidents, improper maintenance, improper protection or improper use. The costs of normal maintenance or repairs for accidents or improper use, and related labor will be borne by the owner.

9. REPLACEMENT PARTS

BEFCO, Inc. warrants replacement parts to be free from defect in material and workmanship for a period of thirty (30) days from the date of delivery to the original purchaser.

WARRANTY REGISTRATION

BEFCO, Inc.
P.O. Box 6036
Rocky Mount, NC 27802-6036

Tel: (252) 977.9920 - Fax: (252) 977.9718

Dealer	Acct. #	Retail Customer
Street	Country	Street
Town	State Zip	Town State Zip
Date of delivery	Invoice #	Phone
Model #	Serial #	
<p>Pre-Delivery Checklist:</p> <p><input type="checkbox"/> Oil in gearbox.</p> <p><input type="checkbox"/> Greased fittings.</p> <p><input type="checkbox"/> Safety guards in place.</p> <p><input type="checkbox"/> All hardware tight.</p> <p><input type="checkbox"/> Bolts torqued correctly.</p> <p><input type="checkbox"/> Attached unit to tractor. Yes/No.</p> <p><input type="checkbox"/> Field adjusted. Yes/No.</p> <p><input type="checkbox"/> Test run. Dry/Infield.</p> <p><input type="checkbox"/> Instruction decals.</p> <p><input type="checkbox"/> Operator's Manual.</p> <p>The machine described above, had been prepared for delivery according to the Pre-Delivery Checklist and the Customer has been instructed in its care and operation and the condition of warranty.</p>		<p>Tractor make: _____</p> <p>Model: _____; HP _____</p> <p>Type of operation: Private homeowner, Landscaping, Commercial maintenance, Golf Course, Municipality, Turf Farm, others: _____</p> <p>Approximate number of acres machine will be used on annually: _____</p> <p>I hereby acknowledge that: I have received and accepted delivery of the machine described. The equipment was checked thoroughly for loose or missing parts and has been adjusted in accordance with the Pre-Delivery Checklist. I have read and understand the nature and extent of the warranty and understand clearly that there were and are no other representations of warranties either expressed or implied, made by anyone. I have been advised on proper operation, maintenance and lubrication procedure of this equipment. I have been instructed on and do understand the application, limitation and capacities this equipment was designed and recommended for, all as described in the Operator's Manual and literature published by the Company.</p>
Inspected by: _____		
Date: _____		Date: _____
Dealer's Signature: _____		Customer's Signature: _____

This registration along with a copy of the invoice must be sent to BEFCO, Inc. within 14 days of date of purchase.

Sender:

Fold here

*Place stamp
here*

BEFCO, Inc.
Warranty Department
P.O. Box 6036
Rocky Mount, NC 27802-6036

Cut along this line



BEFCO[®]

Parts Manual

BABY-HOP

Pull Type Fertilizer Spreader

103-130, 106-130

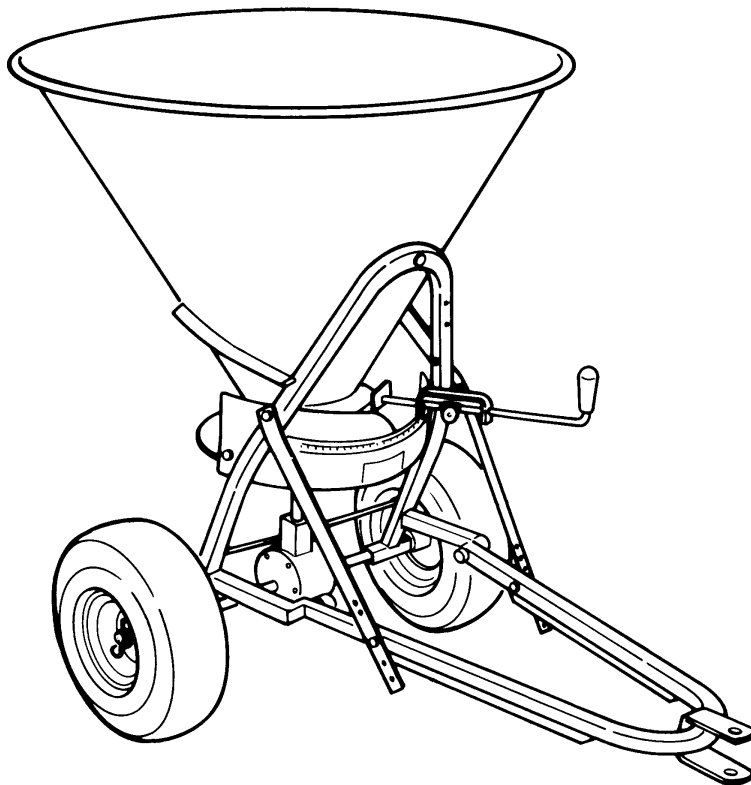

Ref.	Part #	Description	Qty.
2	501-618B	Hopper 103-130	1
	503-882B	Hopper 106-130	1
3	501-658B	Stirrer guard	1
4	501-619B	Stirrer	1
5	501-620B	Bolt M6x30	1
6	005-0165	Lock nut M6	3
7	502-028B	Threaded bushing	1
8	501-623B	Carriage bolt M8x40	1
9	001-5230	Flat washer Ø8	10
10	004-6545	Nut M8	13
11	501-624B	Frame 103-130	1
	503-883B	Frame 106-130	1
14	501-625B	Guard	1
15	501-626B	Hex bolt M8x40	8
16	004-6454	Hex bolt M8x16	2
17	501-628B	Right hitch adjustment	1
18	501-629B	Left hitch adjustment	1
19	501-630B	Shutter lever	1
20	501-631B	Adjustment knob Ø6x16	2
21	501-632B	Right hitch connection	1
22	501-633B	Left hitch connection	1
23	502-029B	Nylon bushing Ø21 103-130	2
	502-029B	Nylon bushing Ø21 106-130	4
25	501-999B	Air tire 13"x6" 103-130	1
	503-884B	Air tire 16"x8" 106-130	1
26	001-4862	Hex bolt M6x45	1
27	001-4514	Flat washer Ø8x24	3
28	502-032B	Axle 103-130	1
	503-682B	Axle 106-130	1
29	005-0166	Flat washer Ø6	5
30	502-034B	Roll pin Ø3x20	1
31	004-6555	Flat washer Ø20	2
32	502-035B	Self tapping screw NTC 3.9x25	6
33	502-036B	Self tapping screw NTC 3.9x16	4
34	501-639B	Adjustment knob	1
35	502-037B	Gearbox housing	1
36	502-038B	Gearbox cover	1
37	502-039B	Bevel gear	1
38	502-040B	Pinion gear	1
39	501-644B	Roll pin Ø5x20	1
40	501-645B	Bearing 6202	2
41	502-041B	Spacer	1
42	502-042B	Gearbox top cover	1
43	501-657B	Cotter pin Ø5	1
44	502-043B	Outgoing shaft	1
45	001-4871	Cotter pin Ø4	2
46	502-044B	Spreader disc	1
47	501-651B	Nut M30	1
48	501-652B	Mobile shutter	1
49	501-653B	Deflector shield (Option)	1
50	501-663B	Carriage bolt M8x25	2

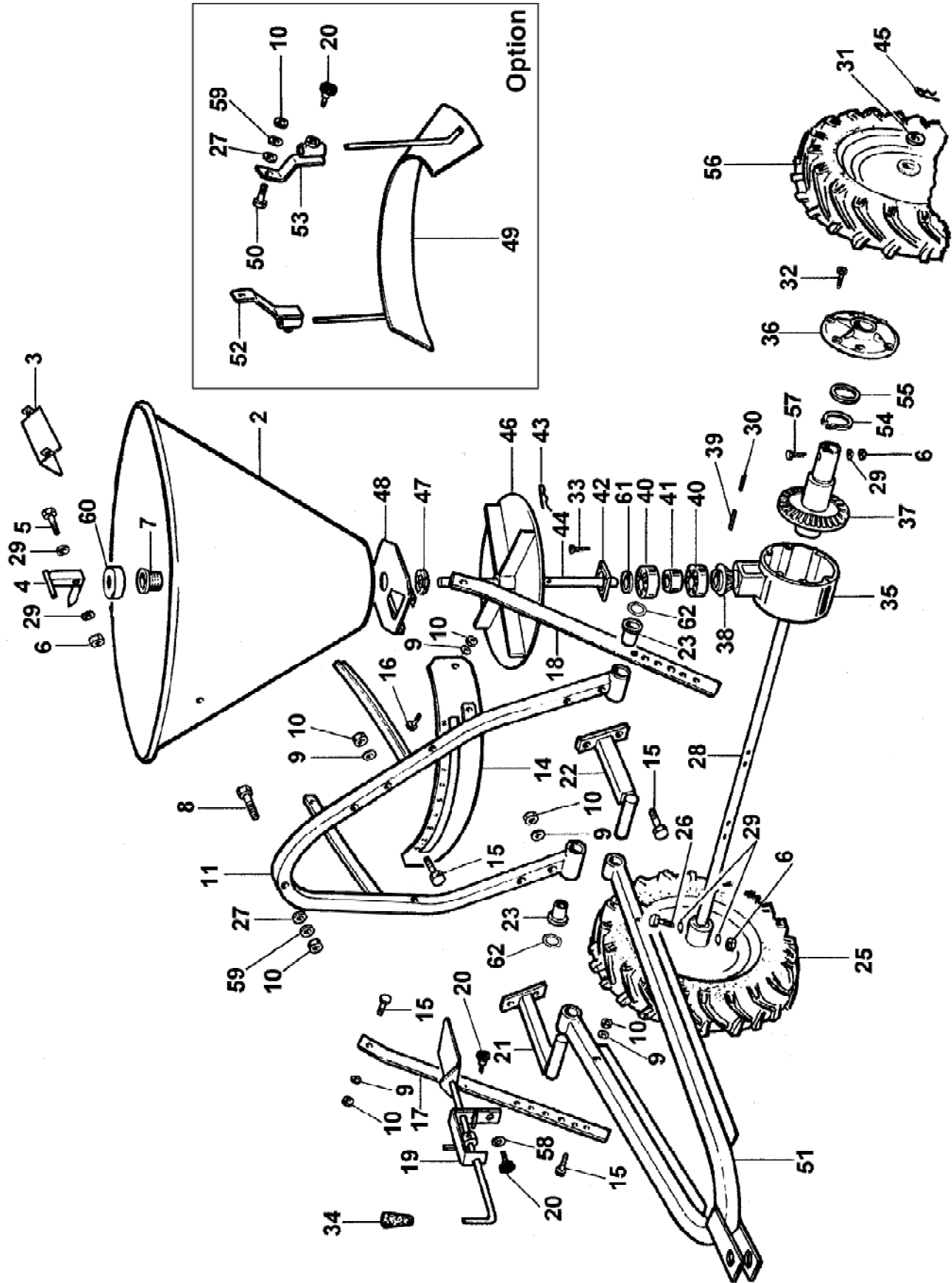

Ref.	Part #	Description	Qty.
51	501-655B	Towing hitch	1
52	502-045B	Right deflector connection	1
53	502-046B	Left deflector connection	1
54	001-0122	Outer snap ring Ø30	1
55	502-048B	Shim Ø30x0.5	1
56	501-999B	Air tire 13"x6" 103-130	1
	503-884B	Air tire 16"x8" 106-130	1
57	005-2418	Hex bolt M6x40	1
58	001-1209	Flat washer M6x18	1
59	000-3144	Lock washer Ø8	3
60	001-4810	Cover	1
61	001-4885	Oil seal 16.24.5	1
62	001-4873	Shim Ø28x0.3	2
	502-051B	Complete gearbox	1
	950-338B	Decal "WARNING - Toxic chemical hazard"	1
	950-339B	Decal "WARNING - Thrown objects, moving parts hazard"	1
	950-417B	Decal "CAUTION - To avoid serious injury"	1
	950-341B	Decal "CAUTION - Do not load hopper until unit has been properly attached"	1
	950-439B	Decal selector "1-10" large	1
	950-440B	Decal selector "1-10" small	1
	950-104B	Decal "B" logo medium	1
	950-381B	Decal "BEFCO INC" address	1
	950-375B	Decal "103"	1
	950-376B	Decal "106"	1
	960-134B	Operator's & Parts Manual Baby-Hop pull-type spreaders 103, 106	-

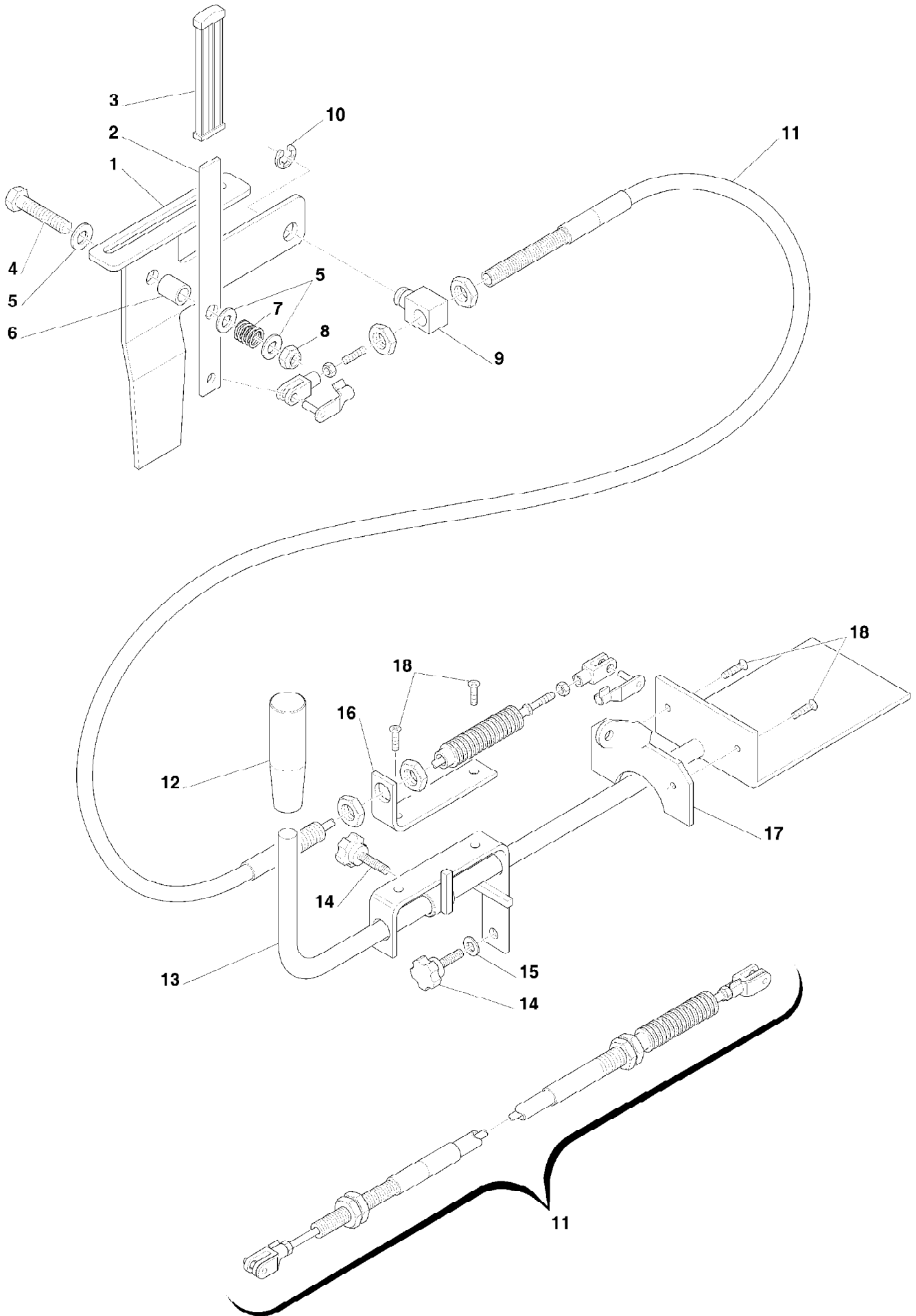

Ref.	Part #	Description	Qty.
1	001-4981	Support plate for remote control	1
2	001-4982	Remote control lever	1
3	001-4983	Flat grooved handle	1
4	001-4477	Bolt M10x60	1
5	000-2034	Flat washer Ø10	3
6	001-4988	Spacer	1
7	001-4989	Spring	1
8	001-5237	Locking nut M10	1
9	001-4990	Cable support	1
10	001-4991	Outer snap ring Ø10	1
11	001-4992	Cable	1
12	501-639B	Adjustment knob	1
13	001-4999	Flow control assembly	1
14	501-631B	Adjustment knob Ø6x16	2
15	001-1209	Flat washer Ø6x18	1
16	001-4993	Cable supporting plate	1
17	001-4994	Cable hitch plate	1
18	001-4998	Bolt M4x10	4
	009-9856	Remote gate control complete 103 & 106 (Option)	

Use only original spare parts

All rights reserved. It is unlawful to copy, reprint or use any of the information or details in this manual without the expressed written permission of the Company. Technical information provided in this manual is approximate, the Company reserves the right to modify or improve the models shown for technical or commercial purposes. Pictures in this manual do not necessarily show the machine as delivered.

BEFCO[®]

P.O. Box 6036

Rocky Mount, NC 27802-6036

Tel.: 252.977.9920 - Fax: 252.977.9718

www.befco.com

