

# ALTER 500

## USER'S MANUAL

IGS Audio Igor Sobczyk  
3 Maja 76d, 41-400 Mysłowice, Poland  
e-mail: [igs@o2.pl](mailto:igs@o2.pl) ph: +48 601 597 592

[www.igsaudio.com](http://www.igsaudio.com)

Please read all of the following instructions and save them or later reference before attempting to connect this unit to the Power DC Supply.

### **COVERS**

**DO NOT** remove the covers or try to repair the module on your own. Refer servicing to qualified personnel only.

### **MOISTURE**

**DO NOT** expose the unit to rain or moisture. If the unit should become so exposed **TURN OFF** the device immediately.

### **HEAT**

**ALWAYS** site the unit away from sources of heat including direct sunlight and ensure adequate ventilation around the unit.

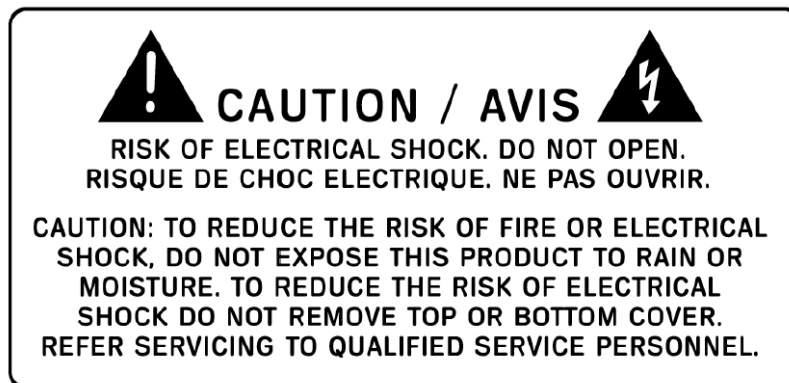

Copyright 2014. All rights reserved.

The information in this document is subject to change without notice.

IGS Audio makes no warranty of any kind with respect to the material in this document and shall not be liable for errors contained herein or for incidental or consequential damages related to the use of the material.

Manual revision: 1.0 (may 2014)



**Thank you for buying this IGS Audio product.**

Please read the information provided below very carefully before using your IGS unit.

### **Unpacking**

Your ALTER 500 has been carefully and meticulously tested and inspected before dispatch. Please check for any signs of transit damage. If any signs of mishandling are found please notify the carrier and your dealer immediately.

Your ALTER 500 packing should contain an ALTER 500 with IGS Audio tag (packed in ESD bag) and this manual with the Warranty and RoHS/CE/WEEE Declaration attached.

### **Compatibility and Power**

The ALTER 500 module is designed to be installed into an API™ 500 Series compatible rack and cannot function stand alone, requiring the power source supplied by the rack system. The current consumption of the ALTER 500 is rated at 120 miliampere per slot. Please check with the rack manufacturer that the design can meet this rating.

### **Mounting**

**WARNING!** Never plug or unplug any 500 series module with the power supply switched on. You may destroy your unit permanently!

The dimensions of all IGS Audio 500 series modules are compatible with API standard. When plugging your new unit to the 500-series rack, no unnecessary force is needed. However, please be careful and do not rush while pushing the unit into the rack sockets, to avoid damaging of the connectors and/or the PCBs of either the unit or the rack.

After the unit is placed in the rack, use the screws provided with your 500-series rack unit to make sure that the unit is safely placed.

When removing the unit from the rack, unscrew the front panel from the rack, and use your fingers to pull it out gently. Do not use any sharp objects (i.e. knives or screwdrivers) to prize it.

## IGS AUDIO ALTER 500 – mono FET Limiting Amplifier

The ALTER 500 is a FET compressor built to the 500 standard. The FET-type solution was used for the first time in its application in the legendary UREI 1176 compressor from the 70s.

The ALTER is a single-channel unit with stepped input and output controls. The Ratio switch has six positions, including two additional to the original 1176 1:1 and 2:1 settings. Slam Mode can be turned on with a separate switch, working regardless of the Ratio settings. Attack and release times can be set to Fast / Mid / Slow with 3-pole switches. The compressor is equipped with a relay bypass, achieved on the front panel. The input is balanced with a modern, low-noise op amp and the output with a Carnhill transformer. The circuit has two amp stages, between which is the output control. The stage amps are based on the discreet API2520 circuit. The level of gain reduction is shown by a 20 point led bar.

### Typical usage:

- ✓ Good for compressing instruments (guitar, bass, mono synth)
- ✓ Great vocal compressor
- ✓ Work well with single drum tracks and samples

Till this day no better vocal compressor has been designed! This is a professional device. Best results are achieved when recordings are made with a good microphone and low noise preamp. Notice

### Block diagram

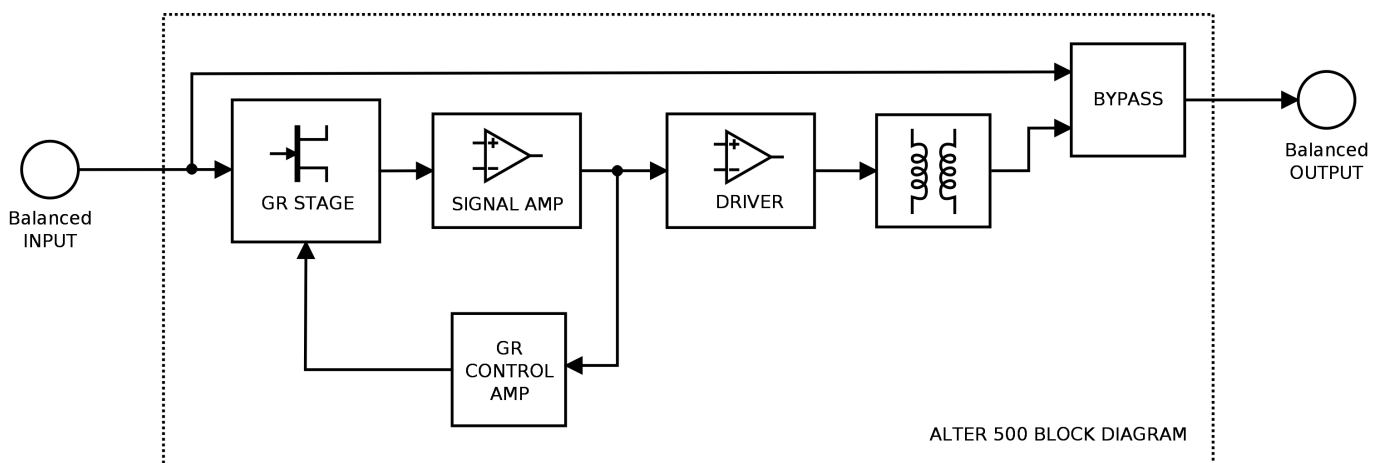

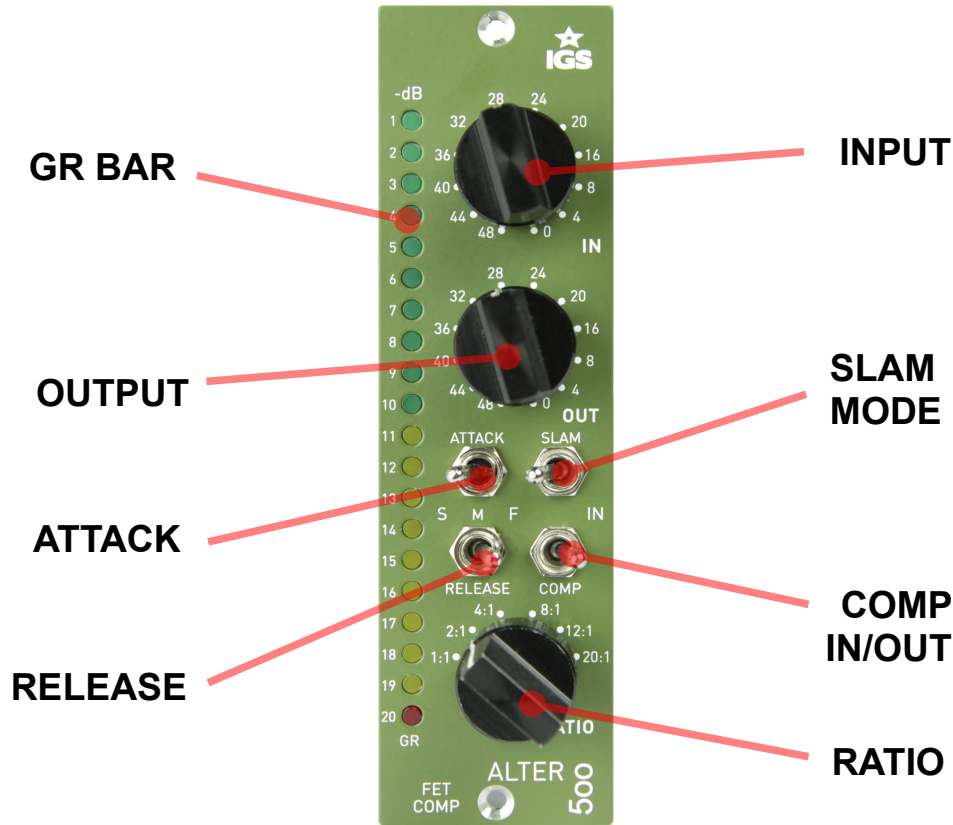

**GR BAR** Very fast LED indicator showing the compression level in the range from 0 to 20dB.

**INPUT** Input level and compression depth

**OUTPUT** Output level

**RATIO** Allows to adjust the compressor ratio. From 1:1 (line amp), through 4:1 (compressor) to 20:1 (limiter).

**ATTACK** Variable Attack - 3 ranges: 20us, 400us, 800us

**RELEASE** Amp recovery time. Range: 50ms, 600ms, 1.1 sec.

**SLAM MODE** Allows the enabling of "All-Buttons-On" mode.

**COMP IN/OUT** Enable Bypass relay device

## Getting started (for the beginners)

1. Connect the Alter 500 to your sound interface (one input and one output) with two symmetrical XLR wires,
2. Wait for about 1 minute to let the parameters stabilize,
3. Send your desired audio file to the selected output,
4. Activate the selected input channel on your local mixer,
5. Set the Input knob to about 36, Output knob to about 16,
6. Set attack to S,
7. Set release to S,
8. Set Ratio to 4:1,
9. Switch Slam off (down position),
10. Play the sound from your source,
11. Turn the Input switch until the compression is satisfying,
12. Turn the Output switch until the audio volume is right,
13. If you need harder compression set the Ratio to a higher setting,
14. To control transients use the Attack switch,
15. If you're looking for aggressive compression based on fast release, turn your Release knob clockwise,
16. Remember that the Bypass switch is a hard wire bypass,

## ALTER 500 main functions and technical specification:

- ✓ 500-series mono module
- ✓ All stepped manipulators
- ✓ Precise LED bar scale
- ✓ Carnhill output transformer
- ✓ 3 year warranty

Operating Level	+4dBu
Maximum Input	+20 dBu
Maximum Output	+22 dBu
Max Gain Reduction	20 dB
Maximum Gain	36 dB
Attack Time	20us, 400us, 800us
Release Time	50ms, 600ms, 1.1 sec.
Input impedance	10 kOhm
Output Impedance	600 Ohm
Frequency response	8Hz to 20kHz; +/- 0.1dB
Noise level dBA	-99dB
THD+N @0dBu	0.012%
Power consumption	2.5 Watts
Shipping weight	0.7kg
Dimensions	H 13,3cm x W 3,8 cm x D 15,8cm

## Troubleshooting

### My unit doesn't light up (LED bar is dark):

- Make sure that the signal source is properly connected to the module
- Adjust the input level (using the Input knob); insufficient input level might cause that the signal level is below the compressor threshold level
- Make sure that the COMP IN/OUT switch is in IN position

### The signal plays thru but there is no change in signal when i turn the knobs:

- Please check the COMP IN/OUT – it should be set to “In”.

### No signal plays thru the unit, regardless the settings at the front panel:

- Please check the cables connecting the rack and or the Power Supply

## **Warranty:**

**This device is declared to be free from defects in material and workmanship for a period of three years. Any device found defective within three years from the delivery date and returned to the factory, will be repaired, adjusted, or replaced and sent to the customer with no charge. The customer always pays the shipping cost to us. This warranty does not cover expendable items such as tubes or fuses. If the defect has been caused by a misuse or abnormal operation conditions, the repair will be billed at a nominal cost. The product should be returned in its original package, if this is possible, or packed in such a way that it is not damaged during the shipment. We are not to be held responsible for any damages during the shipment. 19" units shall always be packed in a box with support for the rack ears. All 500 series modules need to be secured in ESD bag and protected with foam. We will charge the customer €20 + VAT if the packing material needs to be replaced. If we find that the product works perfectly, the customer will be invoiced €50 + VAT to cover our costs of examination and handling plus the cost for returning the product to the customer.**

