

MP134E Q-522 Miniature Stage User Manual

Version: 1.0.0

Date: 24.02.2015

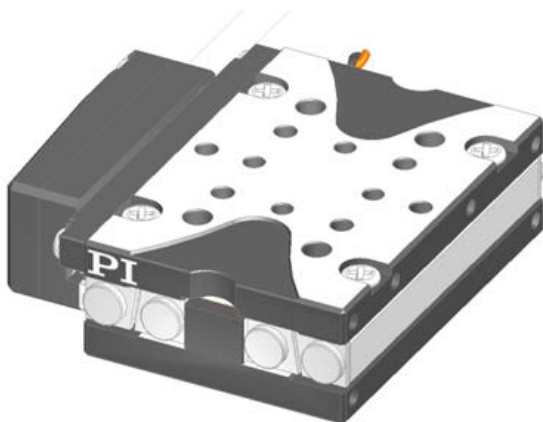

This document describes the following products:

- **Q-522.xyz**
Q-Motion Miniature Linear Stage,
Piezoelectric Inertia Drive

x: Travel range

0 = 6.5 mm

1 = 13 mm

2 = 26 mm

y: Equipment with a sensor

0 = without sensor

4 = with sensor

z: Suitable for vacuum

0 = suitable to 0.1 hPa

U = suitable to 10^{-9} hPa



Physik Instrumente (PI) GmbH & Co. KG is the owner of the following trademarks: PI®, PIC®, PICMA®, PLine®, PIFOC®, PiezoWalk®, NEXACT®, NEXLINE®, NanoCube®, NanoAutomation®, Picoactuator®, PInano®

© 2015 Physik Instrumente (PI) GmbH & Co. KG, Karlsruhe, Germany. The text, photographs and drawings in this manual are protected by copyright. With regard thereto, Physik Instrumente (PI) GmbH & Co. KG retains all the rights. Use of said text, photographs and drawings is permitted only in part and only upon citation of the source.

Original instructions

First printing: 24.02.2015

Document number: MP134E, KSch, version 1.0.0

Subject to change without notice. This manual is superseded by any new release. The latest release is available for download (p. 3) on our website.



Contents

1	About this Document	1
1.1	Goal and Target Audience of this User Manual	1
1.2	Symbols and Typographic Conventions	1
1.3	Definition	2
1.4	Figures	2
1.5	Other Applicable Documents	3
1.6	Downloading Manuals	3
2	Safety	5
2.1	Intended Use	5
2.2	General Safety Instructions	5
2.3	Organizational Measures	6
2.4	Measures for Handling Vacuum-Compatible Products	6
3	Product Description	7
3.1	Model Overview	7
3.2	Product View	10
3.3	Product Labeling	12
3.4	Scope of Delivery	13
3.5	Accessories	13
3.6	Suitable Electronics	14
3.7	Technical Features	15
3.7.1	Linear Encoder (Sensor)	15
3.7.2	Reference Point Switch	15
3.7.3	ID Chip	15
4	Unpacking	17
5	Installation	19
5.1	General Notes on Installation	19
5.2	Mounting the Q-522 on a Surface and Connecting It to a Protective Earth Conductor	21
5.3	Setting Up a Multi-Axis System	24
5.4	Affixing the Load to the Q-522	26
5.5	Connecting the Q-522 to the Electronics	29
5.5.1	Connecting the Q-522 to the Drive Electronics	29
5.5.2	Connecting the Q-522 to the Controller	30

6	Start-Up and Operation	33
6.1	General Notes on Start-Up and Operation	33
6.2	Starting Up the Stage	36
6.2.1	Starting Up the Q-522.x0z with the E-870 Drive Electronics	37
6.2.2	Starting Up the Q-522.x4z with the E-871 Controller	39
7	Maintenance	41
7.1	General Notes on Maintenance	41
7.2	Performing a Maintenance Run	41
7.3	Cleaning the Q-522	41
8	Troubleshooting	43
9	Customer Service	45
10	Technical Data	47
10.1	Specifications	47
10.1.1	Data Table	47
10.1.2	Maximum Ratings	48
10.1.3	Ambient Conditions and Classifications	48
10.2	Operating Time	49
10.3	Dimensions	50
10.3.1	Q-522.00z	50
10.3.2	Q-522.04z	51
10.3.3	Q-522.10z	52
10.3.4	Q-522.14z	53
10.3.5	Q-522.20z	54
10.3.6	Q-522.24z	55
10.4	Pin Assignment	56
10.4.1	Q-522.xy0 (Vacuum-Incompatible)	56
10.4.2	Q-522.xyU (Vacuum-Compatible)	57
11	Old Equipment Disposal	59
12	EC Declaration of Conformity	61

1 About this Document

In this Chapter

Goal and Target Audience of this User Manual	1
Symbols and Typographic Conventions	1
Definition	2
Figures	2
Other Applicable Documents	3
Downloading Manuals	3

1.1 Goal and Target Audience of this User Manual

This manual contains information on the intended use of the Q-522.

It assumes that the reader has a fundamental understanding of basic servo systems as well as motion control concepts and applicable safety procedures.

The latest versions of the user manuals are available for download (p. 3) on our website.

1.2 Symbols and Typographic Conventions

The following symbols and typographic conventions are used in this user manual:

CAUTION



Dangerous situation

If not avoided, the dangerous situation will result in minor injury.



- Actions to take to avoid the situation.

NOTICE



Dangerous situation

If not avoided, the dangerous situation will result in damage to the equipment.

- Actions to take to avoid the situation.

INFORMATION

Information for easier handling, tricks, tips, etc.

Symbol/Label	Meaning
1.	Action consisting of several steps whose sequential order must be observed
2.	
➤	Action consisting of one or several steps whose sequential order is irrelevant
▪	List item
p. 5	Cross-reference to page 5
RS-232	Labeling of an operating element on the product (example: socket of the RS-232 interface)
	Warning sign on the product which refers to detailed information in this manual.

1.3 Definition

Term	Explanation
Load capacity	Maximum load capacity in the vertical direction when the stage is mounted horizontally. The contact point of the load is in the center of the platform.
Linear encoder	The linear encoder is an incremental sensor for capturing changes in position. Signals from the sensor are used for axis position feedback. After switching on the controller a reference point definition must be performed before absolute target positions can be commanded and reached.

1.4 Figures

For better understandability, the colors, proportions and degree of detail in illustrations can deviate from the actual circumstances. Photographic illustrations may also differ and must not be seen as guaranteed properties.

1.5 Other Applicable Documents

The devices and software tools which are mentioned in this documentation are described in their own manuals.

Description	Document
E-870.10, E-870.11, E-870.21, E-870.41 Piezomotor / PiezoMike Drive Electronics, OEM Board, 1 to 4 Channels	E870T0001 Technical Note
E-870.1G, E-870.2G, E-870.4G Piezomotor / PiezoMike Drive Electronics, Bench-Top, 1 to 4 Channels	E870T0002 Technical Note
E-871.1A1 PIShift Controller, 1 Channel, Linear Encoder	PZ241E User Manual
PIMikroMove	SM148E Software Manual

1.6 Downloading Manuals

INFORMATION

If a manual is missing or problems occur with downloading:

- Contact our customer service department (p. 45).

INFORMATION

For some products (e.g. Hexapod systems and electronics that are delivered with a CD), access to the manuals is password-protected. The password is stored on the CD. Availability of the manuals:

- Password-protected manuals: FTP download directory
- Freely available manuals: PI website
- Follow the corresponding instructions for downloading.

Download freely accessible manuals

1. Open the website <http://www.pi-portal.ws>.
2. Click **Downloads**.
3. Click the corresponding product category.
4. Go to the corresponding product code.
The available manuals are displayed.
5. Click the desired manual and save it on the hard disk of your PC or on a data storage medium.

Download password-protected manuals

1. Insert the product CD in the PC drive.
2. Switch to the Manuals directory on the CD.
3. In the Manuals directory, open the Release News (file including **releasenews** in the file name).
4. Find the user name and the password in the section "User login for software download" in the Release News.
5. Open the FTP download directory (<ftp://pi-ftp.ws>).
 - Windows operating systems: Open the FTP download directory in Windows Explorer.
6. Log in with the user name and the password from the Release News.
7. In the directory of the corresponding product, go to the Manuals sub-directory.
8. Copy the desired manual to the hard disk of your PC or to a data storage medium.

2 Safety

In this Chapter

Intended Use	5
General Safety Instructions	5
Organizational Measures.....	6
Measures for Handling Vacuum-Compatible Products	6

2.1 Intended Use

The Q-522 is a laboratory device as defined by DIN EN 61010-1. It is intended to be used in interior spaces and in an environment which is free of dirt, oil, and lubricants.

In accordance with its design and realization, the Q-522 is intended for single-axis positioning, adjusting and shifting of loads at different velocities in interval operation. The Q-522 uses a PIShift piezomotor as a drive. When at rest, the drive is self-locking, requires no current, generates no heat, and maintains its position.

The Q-522 can be mounted in any orientation. The specifications of the Q-522 apply to horizontal mounting (p. 47).

The Q-522 is **not** intended for applications in areas in which a failure would present severe risks to human beings or the environment. For further information on the operating conditions of the Q-522, see "Technical Data" (p. 47).

Some models of the Q-522 are equipped with a linear encoder for direct position measurement.

The intended use of the Q-522 is only possible when completely mounted and connected. The Q-522 must be operated with suitable electronics (p. 14). The electronics is not included in the scope of delivery of the Q-522.

2.2 General Safety Instructions

The Q-522 is built according to state-of-the-art technology and recognized safety standards. Improper use can result in personal injury and/or damage to the Q-522.

- Only use the Q-522 for its intended purpose, and only use it if it is in a good working order.
- Read the user manual.

- Immediately eliminate any faults and malfunctions that are likely to affect safety.

The operator is responsible for the correct installation and operation of the Q-522.

2.3 Organizational Measures

User manual

- Always keep this user manual available by the Q-522. The latest versions of the user manuals are available for download (p. 3) on our website.
- Add all information given by the manufacturer to the user manual, for example supplements or Technical Notes.
- If you pass the Q-522 on to other users, also turn over this user manual as well as other relevant information provided by the manufacturer.
- Only use the device on the basis of the complete user manual. Missing information due to an incomplete user manual can result in minor injury and property damage.
- Only install and operate the Q-522 after having read and understood this user manual.

Personnel qualification

The Q-522 may only be installed, started up, operated, maintained and cleaned by authorized and appropriately qualified personnel.

2.4 Measures for Handling Vacuum-Compatible Products

When handling the vacuum version of the stage, attention must be paid to appropriate cleanliness. At PI, all parts are cleaned before assembly. During assembly and measurement, powder-free gloves are worn. Afterwards, the stage is cleaned once again by wiping and shrink-wrapped twice in vacuum-compatible film.

- Only touch the stage with powder-free gloves.
- If necessary, wipe the stage clean after unpacking.

3 Product Description

In this Chapter

Model Overview	7
Product View	10
Product Labeling.....	12
Scope of Delivery	13
Accessories	13
Suitable Electronics.....	14
Technical Features	15

3.1 Model Overview

Classification of the Q-522 models

Twelve standard versions of the Q-522 stage are available. They differ in terms of the following features:

- Travel range
- Dimensions
- Equipment with a linear encoder
- Suitability for operation in vacuum

Model	Travel range	Dimensions	Linear encoder present	Vacuum suitability (to 10^{-9} hPa)
Q-522.000	6.5 mm	22 mm × 22 mm × 10 mm	No	No
Q-522.040	6.5 mm	32 mm × 22 mm × 10 mm	Yes	No
Q-522.100	13 mm	22 mm × 32 mm × 10 mm	No	No
Q-522.140	13 mm	32 mm × 32 mm × 10 mm	Yes	No
Q-522.200	26 mm	22 mm × 42 mm × 10 mm	No	No
Q-522.240	26 mm	32 mm × 42 mm × 10 mm	Yes	No
Q-522.00U	6.5 mm	22 mm × 22 mm × 10 mm	No	Yes
Q-522.04U	6.5 mm	32 mm × 22 mm × 10 mm	Yes	Yes
Q-522.10U	13 mm	22 mm × 32 mm × 10 mm	No	Yes

Model	Travel range	Dimensions	Linear encoder present	Vacuum suitability (to 10 ⁻⁹ hPa)
Q-522.14U	13 mm	32 mm × 32 mm × 10 mm	Yes	Yes
Q-522.20U	26 mm	22 mm × 42 mm × 10 mm	No	Yes
Q-522.24U	26 mm	32 mm × 42 mm × 10 mm	Yes	Yes

Detailed model names

Order number	Product name
Q-522.000	Q-Motion Miniature Linear Stage, 6.5 mm Travel Range, without Position Sensor, for Open-Loop Operation, 1 N Push/Pull Force, Dimensions 22 × 33 × 10 mm (W × L × H), Piezoelectric Inertia Drive
Q-522.040	Q-Motion Miniature Linear Stage, 6.5 mm Travel Range, Linear Encoder, 1 nm Resolution, 1 N Push/Pull Force, Dimensions 22 × 33 × 10 mm (W × L × H), Piezoelectric Inertia Drive
Q-522.100	Q-Motion Miniature Linear Stage, 13 mm Travel Range, without Position Sensor, for Open-Loop Operation, 1 N Push/Pull Force, Dimensions 22 × 33 × 10 mm (W × L × H), Piezoelectric Inertia Drive
Q-522.140	Q-Motion Miniature Linear Stage, 13 mm Travel Range, Linear Encoder, 1 nm Resolution, 1 N Push/Pull Force, Dimensions 22 × 33 × 10 mm (W × L × H), Piezoelectric Inertia Drive
Q-522.200	Q-Motion Miniature Linear Stage, 26 mm Travel Range, without Position Sensor, for Open-Loop Operation, 1 N Push/Pull Force, Dimensions 22 × 33 × 10 mm (W × L × H), Piezoelectric Inertia Drive
Q-522.240	Q-Motion Miniature Linear Stage, 26 mm Travel Range, Linear Encoder, 1 nm Resolution, 1 N Push/Pull Force, Dimensions 22 × 33 × 10 mm (W × L × H), Piezoelectric Inertia Drive
Q-522.00U	Q-Motion Miniature Linear Stage, 6.5 mm Travel Range, without Position Sensor, for Open-Loop Operation, 1 N Push/Pull Force, Dimensions 22 × 33 × 10 mm (W × L × H), Piezoelectric Inertia Drive, Vacuum-Compatible to 10 ⁻⁹ hPa
Q-522.04U	Q-Motion Miniature Linear Stage, 6.5 mm Travel Range, Linear Encoder, 1 nm Resolution, 1 N Push/Pull Force, Dimensions 22 × 33 × 10 mm (W × L × H), Piezoelectric Inertia Drive, Vacuum-Compatible to 10 ⁻⁹ hPa

Order number	Product name
Q-522.10U	Q-Motion Miniature Linear Stage, 13 mm Travel Range, without Position Sensor, for Open-Loop Operation, 1 N Push/Pull Force, Dimensions 22 x 33 x 10 mm (W x L x H), Piezoelectric Inertia Drive, Vacuum-Compatible to 10 ⁻⁹ hPa
Q-522.14U	Q-Motion Miniature Linear Stage, 13 mm Travel Range, Linear Encoder, 1 nm Resolution, 1 N Push/Pull Force, Dimensions 22 x 33 x 10 mm (W x L x H), Piezoelectric Inertia Drive, Vacuum-Compatible to 10 ⁻⁹ hPa
Q-522.20U	Q-Motion Miniature Linear Stage, 26 mm Travel Range, without Position Sensor, for Open-Loop Operation, 1 N Push/Pull Force, Dimensions 22 x 33 x 10 mm (W x L x H), Piezoelectric Inertia Drive, Vacuum-Compatible to 10 ⁻⁹ hPa
Q-522.24U	Q-Motion Miniature Linear Stage, 26 mm Travel Range, Linear Encoder, 1 nm Resolution, 1 N Push/Pull Force, Dimensions 22 x 33 x 10 mm (W x L x H), Piezoelectric Inertia Drive, Vacuum-Compatible to 10 ⁻⁹ hPa

3.2 Product View

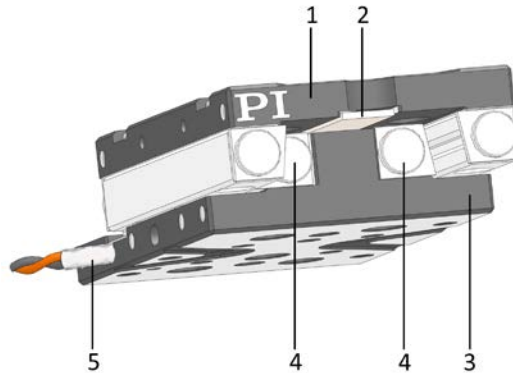

Figure 1: Example of model without linear encoder: Q-522.100 stage

- 1 Moving platform
- 2 Ceramic rail of the drive
- 3 Base body
- 4 Linear guiding
- 5 Cable exit for drive connection

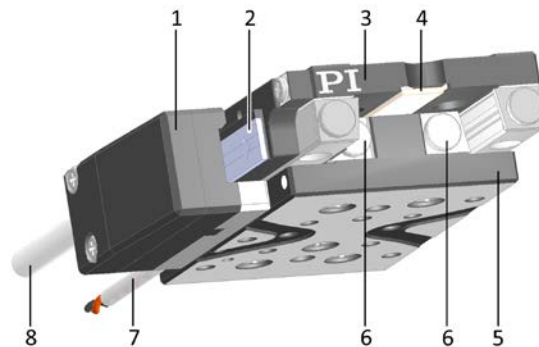

Figure 2: Example of model with linear encoder: Q-522.140 stage

- 1 Case of the linear encoder
- 2 Ruler of the linear encoder
- 3 Moving platform
- 4 Ceramic rail of the drive
- 5 Base body
- 6 Linear guiding
- 7 Cable exit for drive connection
- 8 Cable exit for sensor connection

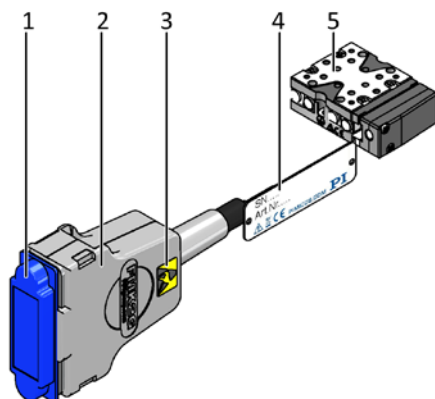

Figure 3: Example: Stage which is not suitable for operation in a vacuum, equipped with sensor

- 1 Only with vacuum-incompatible models with sensor: ESD protective cap
- 2 Connection for drive and sensor; with vacuum-incompatible models: Sub-D 15 (m) connector, with vacuum-compatible models: Sub-D 15 (f) connector
- 3 With vacuum-incompatible models with sensor: Warning sign "Electrostatic sensitive devices"
- 4 Type plate p. 12
- 5 Stage

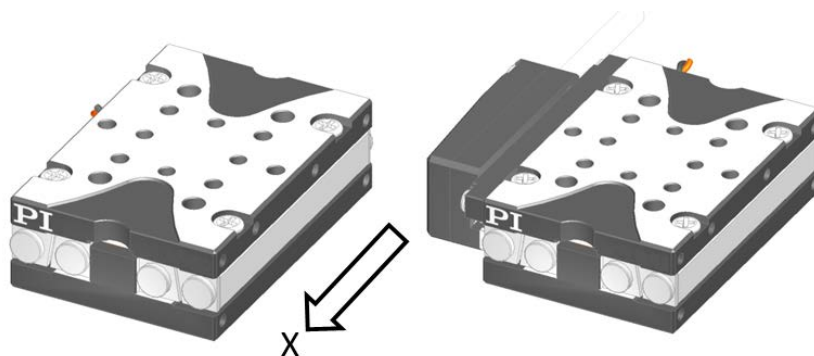

Figure 4: Direction of motion of the Q-522, shown using the Q-522.100 (left) and Q-522.140 with linear encoder (right) for examples

The arrow in the figure above shows the positive direction of motion.

3.3 Product Labeling

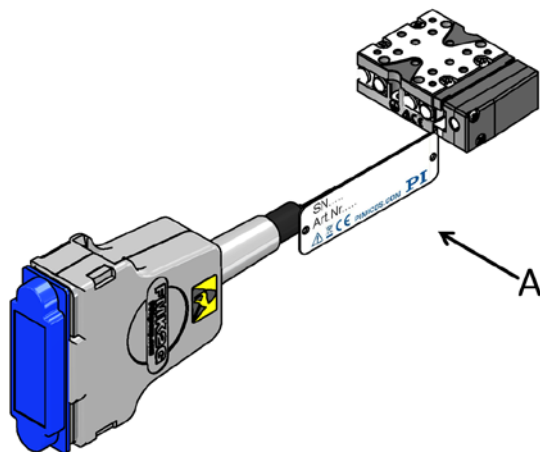

Figure 5: Type plate of the Q-522: Position of the product labeling (example view)

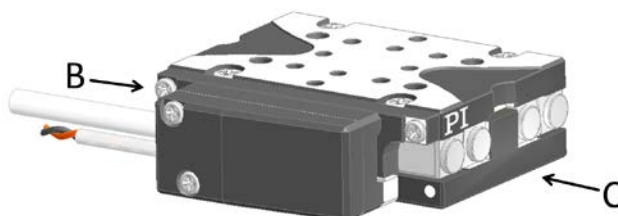





Figure 6: Q-522: Position of the product labeling (example view)

Position	Labeling	Description
A	113064246	Serial number (example), individual for each Q-522 Meaning of the places (counting from left): 1 = internal information, 2 and 3 = manufacturing year, 4 to 9 = consecutive numbers
A	Q-522.140	Product name (example), the places after the point refer to the model
A, B		Warning sign "Observe manual!"
A		Old equipment disposal (p. 59)

Position	Labeling	Description
A, B		CE conformity mark
A	WWW.PIMICOS.COM	Manufacturer's address (website)
A, C		Manufacturer's logo
B		Symbol for the protective earth conductor, marks the protective earth connection of the Q-522

3.4 Scope of Delivery

The Q-522 is delivered with the following components:

Item ID	Components
Q-522	Linear positioning stage as specified in the order (p. 7)
LPS-22.5006	Screw set for mounting the Q-522, consisting of: <ul style="list-style-type: none"> ▪ 2 1.5 m6 x 3 A2 dowel pins ISO 8734 ▪ 2 M2x6 A2 socket head cap screws ISO 4762
MP134E	Manual for Q-522 linear positioning stage
Only with models without sensor which are not suitable for operation in a vacuum:	
7202500042-0015	Adapter cable for connection to the E-870 drive electronics, Sub-D 15 (f) to Mini DIN 4 (m), 0.3 m
Only with models with sensor which are not suitable for operation in a vacuum:	
7202500043-0015	Y-adapter cable for connection to the E-871 controller, Sub-D 15 (f) to HD Sub-D 15 (m) and HD Sub-D 15 (f), 0.3 m

3.5 Accessories

- If you need accessories (e.g. vacuum feedthroughs), contact the customer service department (p. 45).

3.6 Suitable Electronics

Electronics		Suitable for	
Order number	Description	Stage without sensor Q-522.x00 Q-522.x0U	Stage with sensor Q-522.x40 Q-522.x4U
E-870.10	PIShift Piezomotor / PiezoMike Drive Electronics, 1 Channel, OEM Board	<input checked="" type="checkbox"/>	
E-870.11	PIShift Piezomotor / PiezoMike Drive Electronics, 1 Channel, OEM Board with Connector Strip	<input checked="" type="checkbox"/>	
E-870.1G	PIShift Piezomotor / PiezoMike Drive Electronics, 1 Channel, Bench-Top Device	<input checked="" type="checkbox"/>	
E-870.21	PIShift Piezomotor / PiezoMike Drive Electronics, 2 Channels, OEM Board with Connector Strip	<input checked="" type="checkbox"/>	
E-870.2G	PIShift Piezomotor / PiezoMike Drive Electronics, 2 Channels, Bench-Top Device	<input checked="" type="checkbox"/>	
E-870.41	PIShift Piezomotor / PiezoMike Drive Electronics, 4 Channels, OEM Board with Connector Strip	<input checked="" type="checkbox"/>	
E-870.4G	PIShift Piezomotor / PiezoMike Drive Electronics, 2 Channels, Bench-Top Device	<input checked="" type="checkbox"/>	
E-871.1A1	PIShift Controller, 1 Channel, Linear Encoder		<input checked="" type="checkbox"/>

➤ To order, contact our customer service department (p. 45).

3.7 Technical Features

3.7.1 Linear Encoder (Sensor)

Some models of the Q-522 are equipped with an optical linear encoder. For the encoder resolution, refer to the table in the "Specifications" section (p. 47).

Optical linear encoders measure the actual position directly (direct metrology). Therefore, errors occurring in the drivetrain, such as nonlinearity, backlash or elastic deformation, cannot influence the measurement of the position.

3.7.2 Reference Point Switch

The Q-522 models equipped with a sensor have an optical reference point switch.

The commands that use the reference signal are described in the user manual of the controller and/or in the corresponding software manuals.

3.7.3 ID Chip

Q-522 models with sensor contain an ID chip in the connector.

The following data are stored as parameters on the ID chip:

- Information on the stage: Type, serial number, date of manufacture, version of the hardware
- Settings for the sensor: Interpolation rate, corrections of hysteresis as well as of phase and offset, gain values

When switched on or rebooted, controllers from PI read the data from the ID chip.

For more information on the ID chip recognition, see the manual of the controller used.

4 Unpacking

NOTICE



Electrostatic hazard

The Q-522.x40 models (sensor present; not suitable for use in a vacuum) have a Sub-D 15 (m) connector for connection to the electronics.

Touching the pins of the connector can damage electrostatic- (also: ESD-) sensitive components of the Q-522. For this reason, the Q-522.x40 models are equipped with an ESD protective cap on the connector at the time of delivery.

- Remove the ESD protective cap from the connector only when you connect the Q-522 to the controller.

INFORMATION

When handling the vacuum version of the stage, attention must be paid to appropriate cleanliness. At PI, all parts are cleaned before assembly. During assembly and measurement, powder-free gloves are worn. Afterwards, the stage is cleaned once again by wiping and shrink-wrapped twice in vacuum-compatible film.

- Only touch the stage with powder-free gloves.
- If necessary, wipe the stage clean after unpacking.

1. Unpack the Q-522 with care.
2. If present, do **not** remove the ESD protective cap from the connector of the Q-522.
3. Compare the contents against the items covered by the contract and against the packing list.
4. Inspect the contents for signs of damage. If there is any sign of damage or missing parts, contact PI immediately.
5. Keep all packaging materials and the ESD protective cap in case the product needs to be returned.

5 Installation

In this Chapter

General Notes on Installation	19
Mounting the Q-522 on a Surface and Connecting It to a Protective Earth Conductor	21
Setting Up a Multi-Axis System	24
Affixing the Load to the Q-522.....	26
Connecting the Q-522 to the Electronics.....	29

5.1 General Notes on Installation

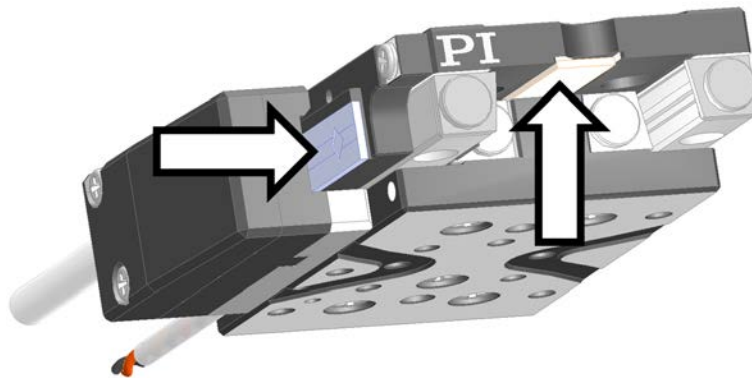

Figure 7: Accessible when the moving platform is driven out: Ceramic rail of the PIShift drive and, for models with sensor, ruler of the linear encoder, example Q-522.140

NOTICE



Damage from mechanical actions!

The ruler of the linear encoder is scratch-sensitive and can be damaged by mechanical actions, e.g. from pointed objects.

- Treat the ruler with extreme care.

NOTICE**Malfunction due to soiling!**

Any type of soiling, e.g. dust, oil, lubricant or condensation, will render the Q-522 inoperable.

- Keep the Q-522 free from dirt and condensation.
- Avoid touching the ceramic rail of the drive and the ruler of the linear encoder.

NOTICE**Electrostatic hazard**

The Q-522.x40 models (sensor present; not suitable for use in a vacuum) have a Sub-D 15 (m) connector for connection to the electronics.

Touching the pins of the connector can damage electrostatic- (also: ESD-) sensitive components of the Q-522. For this reason, the Q-522.x40 models are equipped with an ESD protective cap on the connector at the time of delivery.

- Remove the ESD protective cap from the connector only when you connect the Q-522 to the controller.

NOTICE**Heating up of the Q-522 during operation!**

The heat produced during operation of the Q-522 can affect your application.

- Install the Q-522 so that the application is not impaired by the dissipated heat.
- Ensure sufficient ventilation at the place of installation.
- Make sure that the complete bottom side of the Q-522 is in contact with the surface on which the Q-522 is mounted.

NOTICE**Unintentional changes in position with vertical mounting!**

If the load exceeds the self-locking of the drive when the stage is mounted vertically, unintentional changes in the position of the moving platform occur. Unintentional changes in position of the moving platform can damage the drive, the load or the environment.

- When the stage is mounted vertically, make sure that the installed load is lower than the self-locking of the drive.

NOTICE**Damage from unsuitable cables!**

Unsuitable cables can damage the electronics.

- Only use cables provided by PI for connecting the Q-522 to the electronics.

INFORMATION

For the reproducibility of the positioning to be optimal, all components must be affixed with zero-backlash.

- Make sure that stage and load are affixed with zero-backlash.

INFORMATION

When handling the vacuum version of the stage, appropriate cleanliness must be ensured.

- Only touch the stage with powder-free gloves.
- If necessary, wipe the stage clean.

INFORMATION

The positive direction of motion of the axis is given in the product view (p. 10).

5.2 Mounting the Q-522 on a Surface and Connecting It to a Protective Earth Conductor

NOTICE**Protruding screw heads!**

Protruding screw heads can damage the Q-522.

- Ensure that the screw heads do not protrude from counter-sunk holes so that they do not interfere with the stage motion.

NOTICE



Warping of the Q-522 due to mounting on uneven surfaces!

Mounting the Q-522 on an uneven surface can warp the Q-522. Warping reduces the accuracy.

- Mount the Q-522 on an even surface. The recommended evenness of the surface is $\leq 2 \mu\text{m}$.
- For applications with great temperature changes:
Only mount the Q-522 on surfaces that have the same or similar thermal expansion properties as the Q-522.

INFORMATION

The contact of the Q-522 with the protective earth conductor is made as follows:

- Two counter-sunk holes in the base body of the Q-522
- Suitable conductive screws (p. 13)
- Protective earth conductor connected to the surface on which the Q-522 is mounted

INFORMATION

- Observe the applicable standards for mounting the protective earth conductor.

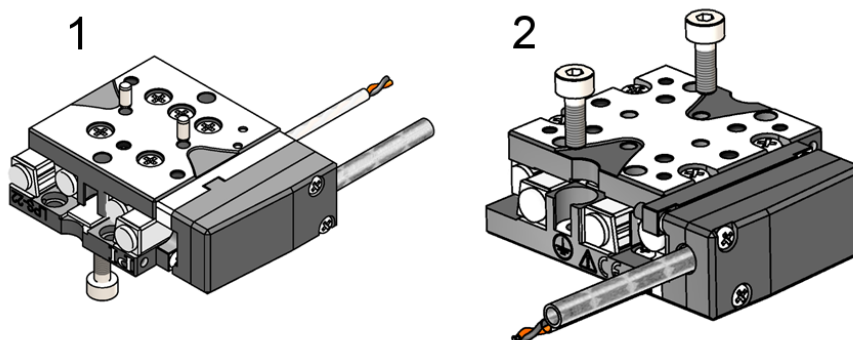

Figure 8: Example Q-522.04z, left: View from below; right: View from top

- 1 Two locating holes on the bottom side of the stage are used for alignment on a surface.
- 2 Two M2 screws are used to mount the stage on the surface.

Prerequisites

- ✓ You have read and understood the general notes on installation (p. 19).
- ✓ The Q-522 is disconnected from the electronics.
- ✓ You have provided a suitable surface (for the required position and depth of the holes for accommodating the screws and locating pins, see "Dimensions" (p. 50)):
 - The surface must be connected to the protective earth conductor.
 - Two locating holes with $\varnothing 1.5$ mm H7 and two M2 mounting holes are available in the surface.
 - The holes for accommodating the screws have to be sufficiently conductive to ensure the proper functioning of the protective earth conductor.
 - For applications with great temperature changes: The surface should have the same thermal expansion properties as the Q-522 (e.g. surface made of aluminum).
 - The evenness of the surface is ≤ 2 μm .
- ✓ You have accounted for the space required for a cable routing free of kinks and in accordance with regulations.

Tools and accessories

- LPS22.5006 screw set from the scope of delivery of the Q-522 (p. 13):
 - 2 1.5 m6 x 3 dowel pins ISO 8734
 - 2 M2x6 socket head cap screws ISO 4762
- Suitable tools for fastening the screws

Mount the Q-522 on a surface and connect it to a protective earth conductor

1. Align the Q-522 on the surface using the locating pins:
 - a) Introduce the two locating pins into the locating holes on the bottom side of the Q-522 (see figure above) or in the surface.
 - b) Place the Q-522 on the surface so that the locating pins are inserted into the corresponding locating holes on the other side.
2. Mount the Q-522 on the surface with two M2 screws.
 - a) Manually displace the moving platform of the Q-522 until one of the two counter-sunk holes in the base body is accessible.

- b) Introduce the screw into the counter-sunk hole.
 - c) Tighten the screw with a maximum torque of 35 Ncm.
 - d) Make sure that the screw head does not protrude from the counter-sunk hole.
 - e) Repeat the steps a) to d) for the other counter-sunk hole in the base body of the Q-522.
3. Make sure that the contact resistance at all connection points relevant for mounting the protective earth conductor is $<0.1 \Omega$ at 25 A.
 4. Check that the Q-522 fits on the surface without backlash.

5.3 Setting Up a Multi-Axis System

The Q-522 can be used in XY systems.

NOTICE



Impermissibly high load on the stages!

In an XY system, the stage for the Y-axis must be moved as well. Impermissibly high loads interfere with the motion and can damage the stages.

- Include the mass of the moved stage in the calculation of the load to be moved.
- For all stages in a multi-axis system: Do **not** exceed the maximum permissible load.
- For all stages in a multi-axis system, make sure that forces that act upon the moving platform in the respective direction of motion do **not** exceed the active push/pull force of the drive (p. 47).

INFORMATION

Any model of the Q-522 can be used as lower or upper stage.

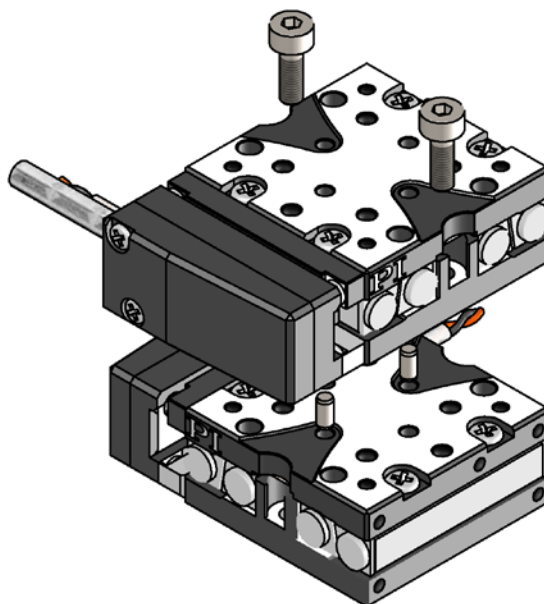

Figure 9: Example: Affixing a Q-522.04z on a Q-522.04z

Prerequisites

- ✓ You have read and understood the general notes on installation (p. 19).
- ✓ The stages are disconnected from the electronics.
- ✓ You have properly mounted the lower stage on a surface and connected it to a protective earth conductor (p. 21).
- ✓ You have accounted for the space required for a cable routing free of kinks and in accordance with regulations.

Tools and accessories

- LPS22.5006 screw set from the scope of delivery of the Q-522 (p. 13):
 - 2 1.5 m6 x 3 dowel pins ISO 8734
 - 2 M2x6 socket head cap screws ISO 4762
- Suitable tools for fastening the screws

Setting up a multi-axis system

1. Insert the two locating pins into the locating holes on the bottom side of the upper Q-522 or in the moving platform of the lower Q-522 (see figures above).
2. Place the upper Q-522 on the lower Q-522 so that the locating pins are inserted into the corresponding locating holes on the other side.
3. Affix the upper Q-522 to the lower Q-522 using two M2 screws:
 - a) Manually displace the moving platform of the upper Q-522 until one of the two counter-sunk holes in the base body is accessible.
 - b) Introduce the screw into the counter-sunk hole.
 - c) Tighten the screw with a maximum torque of 35 Ncm.
 - d) Make sure that the screw head does not protrude from the counter-sunk hole.
 - e) Repeat the steps a) to d) for the other counter-sunk hole in the base body of the Q-522.
4. Check that the upper Q-522 fits on the lower Q-522 without backlash.

5.4 Affixing the Load to the Q-522

NOTICE



Impermissibly high forces and torques!

Impermissibly high forces and torques that are applied to the moving platform can damage the Q-522.

- For affixing type and mass of the load, observe the maximum permissible forces according to the specifications (p. 47).
- Avoid tilting torques at the moving platform.

NOTICE



Screws that are too long!

The Q-522 can be damaged by screws that are too long.

- Note the depth of the mounting holes in the moving platform (p. 50).
- Only use screws of the correct length for the respective mounting holes.

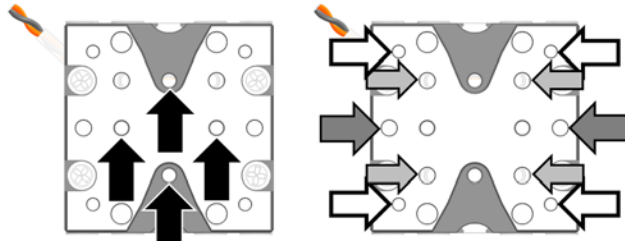

Figure 10: Q-522.00z

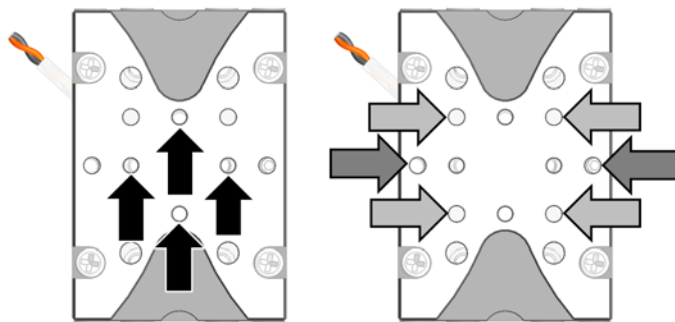

Figure 11: Q-522.10z

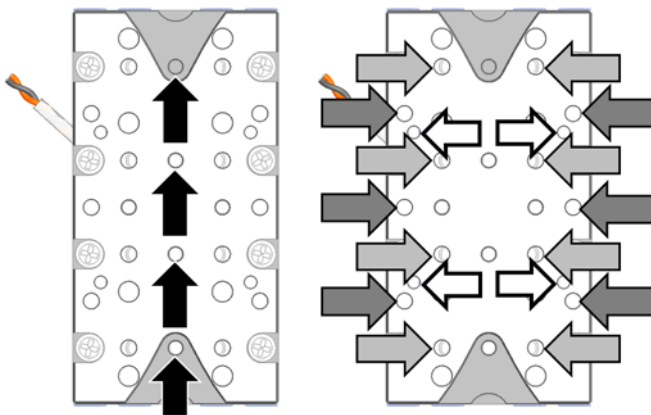

Figure 12: Q-522.20z

The arrows identify the following mounting holes in the moving platform of the Q-522:

For load alignment:

Black arrows: Locating holes \varnothing 1.5 mm H7, depth 2 mm

For affixing the load:

White arrows: M1.6 threaded holes, depth 2.5 mm

Light-gray arrows: M2 threaded holes, depth 2.6 mm

Dark-gray arrows: M2 threaded holes, depth 2.8 mm

Prerequisites

- ✓ You have read and understood the general notes on installation (p. 19).
- ✓ You have properly mounted the stage on a surface (p. 21) or on a Q-522 (p. 24).
- ✓ The stage is disconnected from the electronics.
- ✓ You have prepared the load so that it can be affixed to the moving platform (for the required position and depth of the holes for accommodating the screws and locating pins, see "Dimensions" (p. 50)):
 - The distance between the center of gravity of the load and the center of the moving platform is as small as possible in all directions.
 - At least four points are provided for affixing the load on the moving platform.
 - If you use locating pins for aligning the load: You have made two locating holes of $\varnothing 1.5$ mm H7 in the load for accommodating locating pins.

Tools and accessories

- Screws of suitable length (p. 50). Options:
 - M2 screws
 - Only Q-522.0yz and Q-522.2yz: M1.6 screws
- Suitable tools for fastening the screws
- Optional: 2 locating pins of suitable length, for locating holes with $\varnothing 1.5$ mm H7

Affixing the load to the Q-522

1. Align the load on the Q-522 so that the mounting holes in the load and the holes in the moving platform overlap.
If you use locating pins to align the load:
 - a) Insert the locating pins into the locating holes in the moving platform or the load.
 - b) Place the load on the moving platform so that the locating pins are inserted into the corresponding locating holes on the other side.
2. Affix the load using the screws.
 - Maximum torque for M1.6 screws: 17 Ncm
 - Maximum torque for M2 screws: 35 Ncm
3. Check that the load fits on the moving platform of the stage without backlash.

5.5 Connecting the Q-522 to the Electronics

The presence of a sensor defines the electronics to be used to operate the Q-522 (see also "Suitable Electronics" (p. 14)):

- Models without sensor (Q-522.x0z): E-870 drive electronics (p. 29)
- Models with sensor (Q-522.x4z): E-871 controller (p. 30)

INFORMATION

The Q-522 and the electronics can be delivered as a pre-configured system.

- If a connection assignment is given on the labels of the Q-522 and/or electronics, observe this assignment when connecting the Q-522.

5.5.1 Connecting the Q-522 to the Drive Electronics

INFORMATION

- For information regarding the connection of a vacuum-compatible Q-522, contact the customer service department (p. 45).

Prerequisites

- ✓ You have read and understood the general notes on installation.
- ✓ You have installed the E-870 drive electronics (p. 14).
- ✓ You have read and understood the user manual of the drive electronics.
- ✓ The drive electronics is switched off, i.e. **not** connected to the power source.

Tools and accessories

- If the drive electronics has a Mini-DIN 4 socket (models: E-870.x1, E-870.xG): 7202500042-0015 adapter cable, in the scope of delivery (p. 13)
- If the drive electronics has a connector strip (model E-870.10): Suitable adapter from Sub-D 15 (f) to the connector strip:
 - The pin assignment of the J10 connector strip (2x4 pin) can be found in the E870T0001 Technical Note.
 - If you need a suitable adapter, contact our customer service department (p. 45).

Connecting the Q-522.x00 to E-870 drive electronics with a Mini-DIN 4 socket

1. Connect the Q-522.x00 with the adapter cable:
 - Connect the Sub-D 15 (m) connector of the Q-522 with the connector of the adapter cable (Sub-D 15 (f)).
2. Connect the adapter cable with the drive electronics:
 - a) Connect the Mini-DIN 4 connector of the adapter cable with the Mini-DIN 4 socket of the drive electronics.
 - b) Take suitable measures to prevent the adapter cable from being accidentally disconnected.

Connecting the Q-522.x00 to E-870 drive electronics with a connector strip

- Connect the Q-522.x00 to the connector strip of the drive electronics using a suitable adapter.

5.5.2 Connecting the Q-522 to the Controller

INFORMATION

- For information regarding the connection of a vacuum-compatible Q-522, contact the customer service department (p. 45).

Prerequisites

- ✓ You have read and understood the general notes on installation.
- ✓ You have installed the E-871 controller (p. 14).
- ✓ You have read and understood the user manual of the controller.
- ✓ The controller is switched off, i. e. the power supply is **not** connected to the power socket via the power cord.

Tools and accessories

- Y adapter cable 7202500043-0015, in the scope of delivery (p. 13).

Connect the Q-522.x40 to the E-871 controller

1. Connect the Q-522.x40 with the Y adapter cable:
 - a) Remove the ESD protective cap from the Sub-D 15 (m) connector of the Q-522.
 - b) Connect the Sub-D 15 (m) connector of the Q-522 with the connector of the Y adapter cable (Sub-D 15 (f)).
2. Connect the Y adapter cable with the E-871 controller:
 - a) Connect the HD Sub-D 15 (m) connector for motor connection to the corresponding socket of the controller (see user manual of the controller).
 - b) Connect the HD Sub-D 15 (f) connector for sensor connection to the panel plug of the controller (see user manual of the controller).
3. Secure the connections with the integrated screws against accidental disconnection.

6 Start-Up and Operation

In this Chapter

General Notes on Start-Up and Operation	33
Starting Up the stage	36

6.1 General Notes on Start-Up and Operation

CAUTION



Risk of electric shock if the protective earth conductor is not connected!

If a protective earth conductor is not or not properly connected, dangerous touch voltages can occur on the Q-522 in the case of malfunction or failure of the system. If touch voltages exist, touching the Q-522 can result in minor injuries from electric shock.

- Connect the Q-522 to a protective earth conductor (p. 21) before start-up.
- Do **not** remove the protective earth conductor during operation.
- If the protective earth conductor has to be removed temporarily (e. g. in the case of modifications), reconnect the Q-522 to the protective earth conductor before starting it up again.

CAUTION



Burning from hot surface!

The surface of the Q-522 and its vicinity can heat up during operation. Touching the Q-522 and surrounding parts can result in minor injuries from burning.

- Cool the Q-522 so that the temperature of its surface and surrounding parts does **not** exceed 65 °C.
- If sufficient cooling is not possible: Make sure that the hot Q-522 and its surrounding parts **cannot** be touched.
- If sufficient cooling and protection against contact are not possible: Mark the danger zone in accordance with the legal regulations.

NOTICE**Overheating during continuous operation!**

The highest velocity is achieved at maximum operating frequency; however, the Q-522 can overheat during continuous operation as a result.

- Observe the recommended operating time according to the operating frequency in step mode (p. 49).
- Ensure sufficient ventilation at the place of installation.

NOTICE**Damage from collisions!**

Collisions can damage the stage, the load to be moved and the environment.

- Make sure that no collisions are possible between the stage, the load to be moved and the environment in the motion range of the stage.
- Do not place any objects in areas where they can get caught by moving parts.
- Stop the motion immediately if an electronics malfunction occurs.

NOTICE**Operating frequency too high!**

An operating frequency that is too high can cause damage to the Q-522.

- Only operate the Q-522 with controllers/drivers and original accessories from PI.
- Do **not** exceed the operating frequency range (p. 48) for which the Q-522 is specified.

NOTICE**Considerable wear due to high operating frequency!**

A high operating frequency in step mode can cause considerable wear on the mechanical system.

- When the E-870 drive electronics is used:
 - If necessary, reduce the values of the parameters **PIShift Steps per Second** (ID 0x1F000600) and **PIShift Frequency** (ID 0x1F000400) on the drive electronics, see documentation of the drive electronics.
- When the E-871 controller is used:
 - When the **PIShift Open-Loop Driving Mode** (ID 0x1F000702) parameter has a value of 0 (step mode) and motions in open-loop operation are initiated with the SMO command: The step frequency depends directly from the control value commanded with SMO and is limited by the value of the **Maximum Motor Output** (ID 0x9) parameter. If necessary, reduce the commanded control value and the value of the **Maximum Motor Output** parameter.
- Reduce the operating time with a high operating frequency (p. 49).
- Stop the motion immediately if an electronics malfunction occurs.

NOTICE**Operating voltage too high or incorrectly connected!**

Operating voltages that are too high or incorrectly connected can cause damage to the Q-522.

- Only operate the Q-522 with controllers/drivers and original accessories from PI.
- Do **not** exceed the operating voltage range (p. 48) for which the Q-522 is specified.
- Only operate the Q-522 when the operating voltage is properly connected; see "Pin Assignment" (p. 56).

NOTICE**Reduced lifetime of the piezo actuator due to permanently high voltage!**

The permanent application of a high static voltage to piezo actuators leads to a considerable reduction in the lifetime of the piezo ceramic of the stage.

- When the Q-522 is not used, switch off the electronics.

NOTICE**Destruction of the piezo actuators by electric flashovers!**

Using the Q-522 in environments that increase the electrical conductivity can lead to the destruction of the piezo actuators of the drive by electric flashovers. Electric flashovers can be caused by moisture, high humidity, liquids and conductive materials (e.g. metal dust). In addition, electric flashovers can also occur in certain air pressure ranges due to the increased conductivity of the air.

- Avoid operating the Q-522 in environments that can increase the electrical conductivity.
- Only operate the Q-522 within the permissible ambient conditions and classifications (p. 48).
- For operation in vacuum below 0.1 hPa:
Do **not** operate the Q-522 during evacuation.

NOTICE**Increased wear due to small working range!**

Using a small working range permanently increases the wear in this region.

- If possible: Select another part of the travel range for the working range in regular intervals.

6.2 Starting Up the Stage

The presence of a sensor defines the electronics to be used to operate the Q-522 (see also "Suitable Electronics" (p. 14)):

- Models without sensor (Q-522.x0z): E-870 drive electronics (p. 37)
- Models with sensor (Q-522.x4z): E-871 controller (p. 39)

INFORMATION

If the parameters of the electronics are not adapted to the Q-522 and the application (load, orientation of the Q-522), the Q-522 will either not move or not move satisfactorily.

- Only operate the Q-522 when the parameters of the electronics have been correctly set.
- Pay particular attention to the parameter settings for operating voltage and operating frequency.

INFORMATION

The PIShift drive develops noises in step mode. The noise development depends on the current step frequency.

6.2.1 Starting Up the Q-522.x0z with the E-870 Drive Electronics

INFORMATION

The values for the parameters of the E-870 drive electronics are listed in a table in this section (p. 38).

For optimum drive performance, the values of the following parameters should be identical:

- **PIShift Steps per Second** (ID 0x1F000600)
- **PIShift Frequency** (ID 0x1F000400)

Prerequisites

- ✓ You have read and understood the general notes on start-up and operation (p. 33).
- ✓ You have read and understood the documentation of the E-870 drive electronics (E870T0001 Technical Note or E870T0002 Technical Note).
- ✓ You have properly installed the stage (p. 19).
- ✓ The E-870 drive electronics has been properly installed, and all connections on the E-870 have been set up (see E870T0001 Technical Note or E870T0002 Technical Note).

Starting up the Q-522.x0z with the E-870 drive electronics

1. Make sure that the parameters of the E-870 drive electronics have been set correctly; for values, see table below (p. 38).
2. Provide the control signal required for operating the system. Details can be found in the E870T0001 or E870T0002 Technical Note.
3. If necessary: Adapt the **PIShift Steps per Second** parameter (ID 0x1F000600) and the **PIShift Frequency** parameter (ID 0x1F000400) to your application (see also "Operating Time" (p. 49)).

The following table lists the settings for the parameters of the E-870 drive electronics. Further information on the parameter settings is found in the "Operating Time" section (p. 49).

Parameter	Parameter in E-870 Drive Electronics	Value	Unit
Operating voltage, upper limit	<i>PIShift Upper Supply Voltage</i> ID 0x1F000000	48	V
Operating voltage, lower limit	<i>PIShift Lower Supply Voltage</i> ID 0x1F000100	0	V
Charging current during forward motion	<i>PIShift Forward Current</i> ID 0x1F000200	0.2	A
Charging current during backward motion	<i>PIShift Backward Current</i> ID 0x1F000300	-0.2	A
Operating frequency in step mode	<i>PIShift Frequency</i> ID 0x1F000400	20000	Hz
Duty cycle of the current source during the output of one period of the modified sawtooth signal in step mode	<i>PIShift Charge Cycle</i> ID 0x1F000500	1	-
Number of steps the stage moves per second at the set operating frequency.	<i>PIShift Steps per Second</i> ID 0x1F000600	20000	

6.2.2 Starting Up the Q-522.x4z with the E-871 Controller

INFORMATION

If you use the software included in the scope of delivery of the E-871 controller, the operating parameters can be loaded from the *PIMicosStages2.dat* stage database. The entries in the stage database are updated regularly.

- Download the PI Update Finder from the PI website (<http://www.update.pi-portal.ws>) and use it to update the *PIMicosStages2.dat* stage database on your PC.

For further information, see the user manual of the E-871 controller.

INFORMATION

For optimum drive performance in step mode, the **Maximum Motor Output** (ID 0x9) parameter in the *PIMicosStages2.dat* stage database takes a value of 15 kHz.

For further information, see "Operating Time" (p. 49) and user manual of the E-871 controller.

Prerequisites

- ✓ You have read and understood the general notes on start-up and operation (p. 33).
- ✓ You have properly installed the stage (p. 19).
- ✓ You have read and understood the user manual of the controller.
- ✓ You have read and understood the manual of the PC software.
- ✓ The controller and the required PC software have been installed. All connections on the controller have been set up (see user manual of the controller).

Starting up the Q-522.x4z with the E-871 controller

1. Start up the stage (see E-871 user manual).
The start-up comprises the following steps:
 - Selecting the stage type
 - Defining the reference point of the axis
 - Commanding first motions for testing

2. If necessary: Adapt the **Maximum Motor Output** (ID 0x9) parameter to your application (also refer to "General Notes on Start-Up and Operation" (p. 33) and "Operating Time" (p. 49)).

The E-871 user manual describes the start-up using the PIMikroMove program.

7 Maintenance

In this Chapter

General Notes on Maintenance.....	41
Performing a Maintenance Run.....	41
Cleaning the Q-522	41

7.1 General Notes on Maintenance

NOTICE



Damage due to improper maintenance!

Improper maintenance can lead to misalignment and failure of the Q-522.

- Only loosen screws according to the instructions in this manual.

7.2 Performing a Maintenance Run

The maintenance run must cover the entire travel range.

- Perform the maintenance run after every 10 million steps.

7.3 Cleaning the Q-522

Prerequisites

- ✓ You have disconnected the stage from the electronics.

Cleaning the stage

Only when the stage is **not** used in vacuum:

- When necessary, clean the surfaces of the stage with a cloth that is lightly dampened with a mild cleanser or disinfectant.

Only when the stage is used in vacuum:

- Only touch the stage with powder-free gloves.
- If necessary, wipe the stage clean.

8 Troubleshooting

Problem	Possible Causes	Solution
Functional impairment after system modification	<ul style="list-style-type: none"> ▪ Drive electronics or controller has been replaced ▪ The stage has been replaced 	<p>E-870 drive electronics from PI:</p> <ul style="list-style-type: none"> ➤ Adapt the parameters of the drive electronics in the E-870 Control PC program to the Q-522 (see "Starting Up the Q-522.x0z with the E-870 Drive Electronics" (p. 37) and Technical Note E870T0001 or E870T0002). <p>E-871 controller from PI:</p> <ul style="list-style-type: none"> ➤ Load the parameter set corresponding to the Q-522 model from the stage database. ➤ If necessary: Set the parameters on the controller in the PIMikroMove PC program so that they correspond to the application (load, orientation) of the Q-522 model (see user manual of the controller).
No or limited motion	The cable is not connected correctly or is defective	<ul style="list-style-type: none"> ➤ Check the connecting cable(s)
	Excessive load	<ul style="list-style-type: none"> ➤ Reduce the load. Observe the information in the "Technical Data" section (p. 47). ➤ If the stage is mounted vertically, make sure that the installed load is lower than the self-locking of the drive.
	Parameters of the drive electronics incorrectly set	<ul style="list-style-type: none"> ➤ See the "Functional impairment after system modification" problem in this table.
	Operating voltage too low	<ul style="list-style-type: none"> ➤ Provide an operating voltage of 48 V.
	Unfavorable operating frequency for step mode	<ul style="list-style-type: none"> ➤ Adapt the operating frequency for the step mode (for details, see "Starting Up the Stage" (p. 36) and manual of the electronics used.
	Warped base body	<ul style="list-style-type: none"> ➤ Mount the Q-522 on an even surface. The recommended evenness of the surface is 2 µm.
	Unfavorable load mounting	<ul style="list-style-type: none"> ➤ Observe the maximum torque when affixing the load (p. 26). ➤ Keep the distance between the center of gravity of the load and the center of the moving platform as small as possible in all directions.
	Unsuitable ambient conditions	<ul style="list-style-type: none"> ➤ Only operate the Q-522 in a clean environment and within the permissible ambient conditions (p. 48).
	Wear of the drive	<ul style="list-style-type: none"> ➤ Replace the Q-522 and make sure that the operating parameters of the used electronics are adapted to the stage.

Problem	Possible Causes	Solution
	Drive is blocked	<ul style="list-style-type: none"><li data-bbox="691 432 1326 495">➤ Carefully release the blockage by manually moving the moving platform back and forth.<li data-bbox="691 501 1265 528">➤ Contact our customer service department (p. 45).

If the problem that occurred with your system is not listed in the table above or cannot be solved as described, contact our customer service department (p. 45).

9 Customer Service

For inquiries and orders, contact your PI sales engineer or send us an e-mail (info@pi.ws).

If you have questions concerning your system, have the following information ready:

- Product codes and serial numbers of all products in the system
- Firmware version of the controller (if present)
- Version of the driver or the software (if present)
- Operating system on the PC (if present)

The latest versions of the user manuals are available for download (p. 3) on our website.

10 Technical Data

In this Chapter

Specifications 47
 Operating Time..... 49
 Dimensions 50
 Pin Assignment..... 56

10.1 Specifications

10.1.1 Data Table

Preliminary Data	Q-522.040 / Q-522.04U	Q-522.140 / Q-522.14U	Q-522.240 / Q-522.24U	Q-522.x00 / Q-522.x0U	Unit
Motion and positioning	6.5 mm travel range, resolution 1 nm, UHV version Q-522.04U	13 mm travel range, resolution 1 nm, UHV version Q-522.14U	26 mm travel range, resolution 1 nm, UHV version Q-522.24U	6.5 mm to 26 mm travel range, open-loop, UHV versions Q-522.x0U	
Active axis	X	X	X	X	
Travel range	6.5	13	26	6.5 to 26	mm
Integrated sensor	Linear encoder	Linear encoder	Linear encoder	-	
Resolution	1	1	1	-	nm
Maximum velocity	10	10	10	10	mm/s
Mechanical properties					
Load capacity	10	10	10	10	N
Push / pull force	1	1	1	1	N
Length	22	32	42	22 to 42	mm
Width	32	32	32	22	mm
Height	10	10	10	10	mm
Drive properties					
Motor type	Piezoelectric inertia drive	Piezoelectric inertia drive	Piezoelectric inertia drive	Piezoelectric inertia drive	



Preliminary Data	Q-522.040 / Q-522.04U	Q-522.140 / Q-522.14U	Q-522.240 / Q-522.24U	Q-522.x00 / Q-522.x0U	Unit
Miscellaneous					
Operating temperature range	0 to 40	0 to 40	0 to 40	0 to 40	°C
Material	Aluminum	Aluminum	Aluminum	Aluminum	
Cable length	1	1	1	1	m
Connector	Sub-D	Sub-D	Sub-D	Sub-D	
Recommended controller	E-871	E-871	E-871	E-870	

Ask about custom designs!

The Q-522 stage series replaces the LPS-22 series.

10.1.2 Maximum Ratings

The Q-522 stage is designed for the following operating data:

Maximum Operating Voltage	Maximum Operating Frequency	Maximum Power Consumption
		
48 V	20 kHz	10 W

10.1.3 Ambient Conditions and Classifications

The following ambient conditions and classifications must be observed for the Q-522:

Area of application	For indoor use only
Maximum altitude	2000 m
Air pressure	Q-522.xy0: 1100 hPa to 0.1 hPa Q-522.xyU: 1100 hPa to 10 ⁻⁹ hPa

Relative humidity	Highest relative humidity 80 % for temperatures up to 31 °C, non-condensing Decreasing linearly to 50 % relative humidity at 40 °C, non-condensing
Operating temperature	0 °C to 40 °C
Storage temperature	-20 °C to 70 °C
Transport temperature	-20 °C to 70 °C
Maximum bakeout temperature for vacuum-compatible products	Q-522.xyU: 120 °C, for 12 hours, only in switched-off state
Overvoltage category (in acc. with EN 60664-1:2007 / VDE 0110-1)	II
Protection class (acc. to EN 61140 / VDE 0140-1)	I
Degree of pollution (acc. to EN 60664-1:2007 / VDE 0110-1)	1
Degree of protection (acc. to IEC 60529)	IP20

10.2 Operating Time

The operating time and the operating frequency in step mode affect the lifetime of the stage. In order to prevent overheating and high wear, the operating time with given operating frequency and 100 % duty cycle should not exceed the values given in the following table.

Operating frequency in Hz ¹	Operating time ² / 48 V, ±0.2 A
20000	10 s (max.)
10000	20 s (max.)
5000	60 s (max.)
≤ 1000	120 s (max.)

¹ For the relevant parameters see "Starting Up the Stage" (p. 36) and the user manual of the electronics used.

² With 100 % duty cycle without heat dissipation

10.3 Dimensions

10.3.1 Q-522.00z

Dimensions in mm

Signs that are used to separate decimal places:

- Depth and diameter of holes: Point
- All other dimensions: Comma

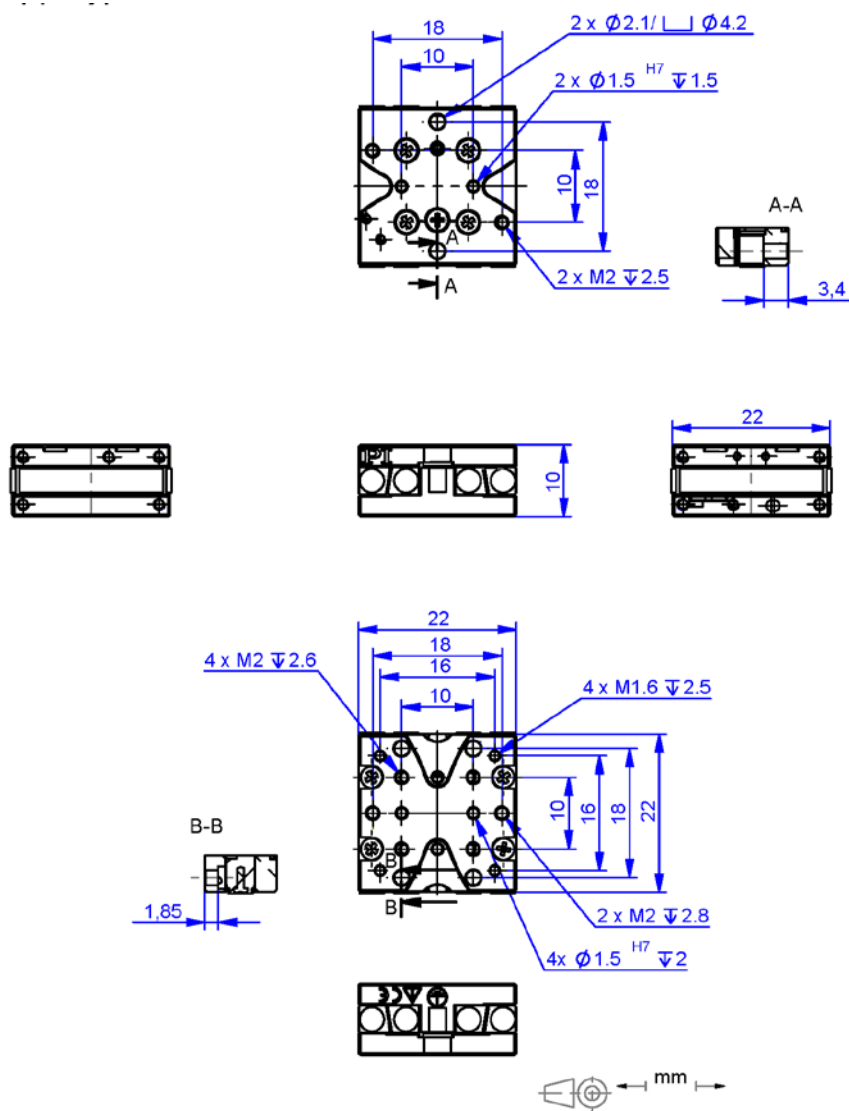

Figure 13: Q-522.00z

10.3.2 Q-522.04z

Dimensions in mm

Signs that are used to separate decimal places:

- Depth and diameter of holes: Point
- All other dimensions: Comma

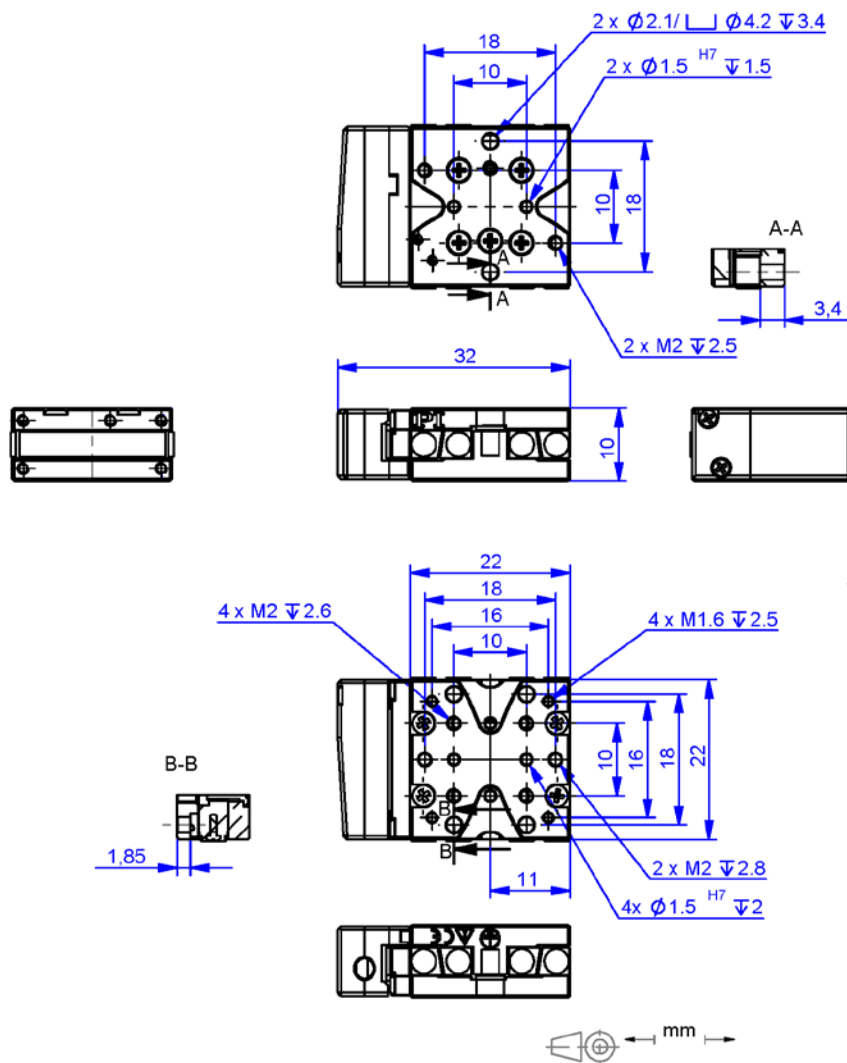

Figure 14: Q-522.04z

10.3.3 Q-522.10z

Dimensions in mm

Signs that are used to separate decimal places:

- Depth and diameter of holes: Point
- All other dimensions: Comma

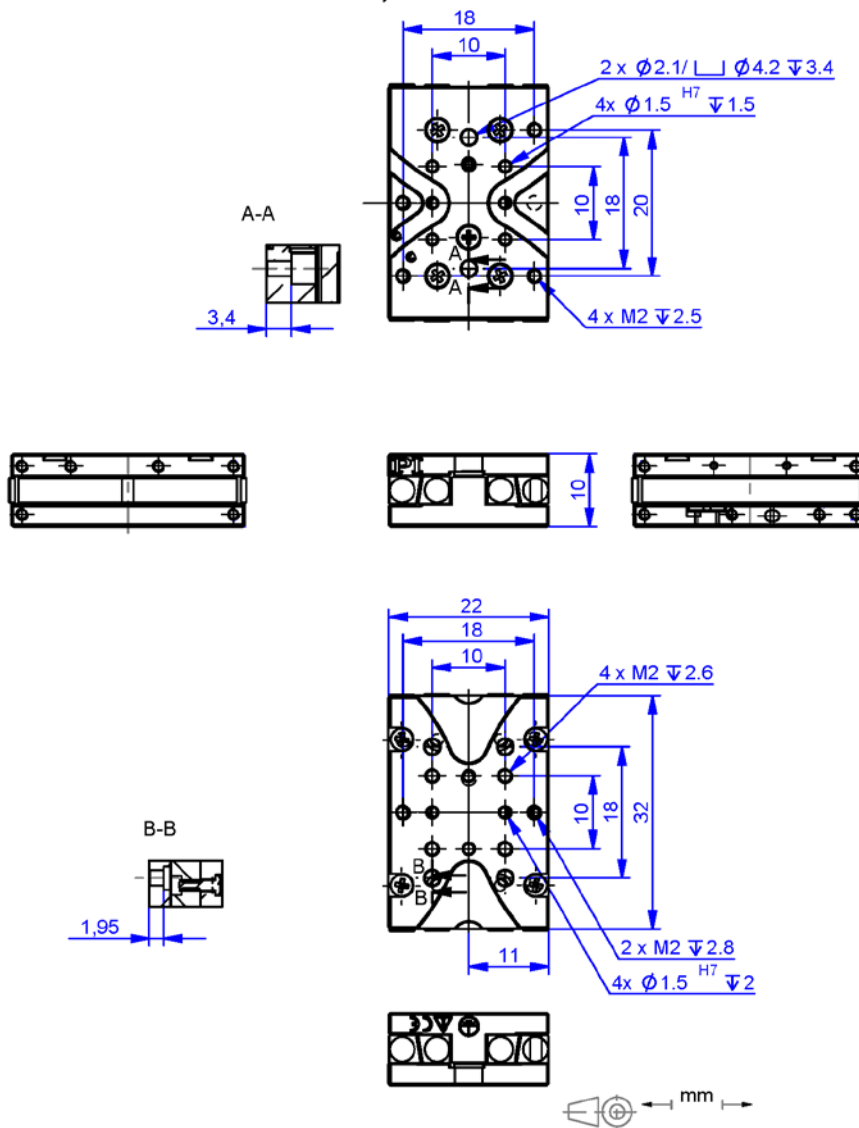

Figure 15: Q-522.10z

10.3.4 Q-522.14z

Dimensions in mm

Signs that are used to separate decimal places:

- Depth and diameter of holes: Point
- All other dimensions: Comma

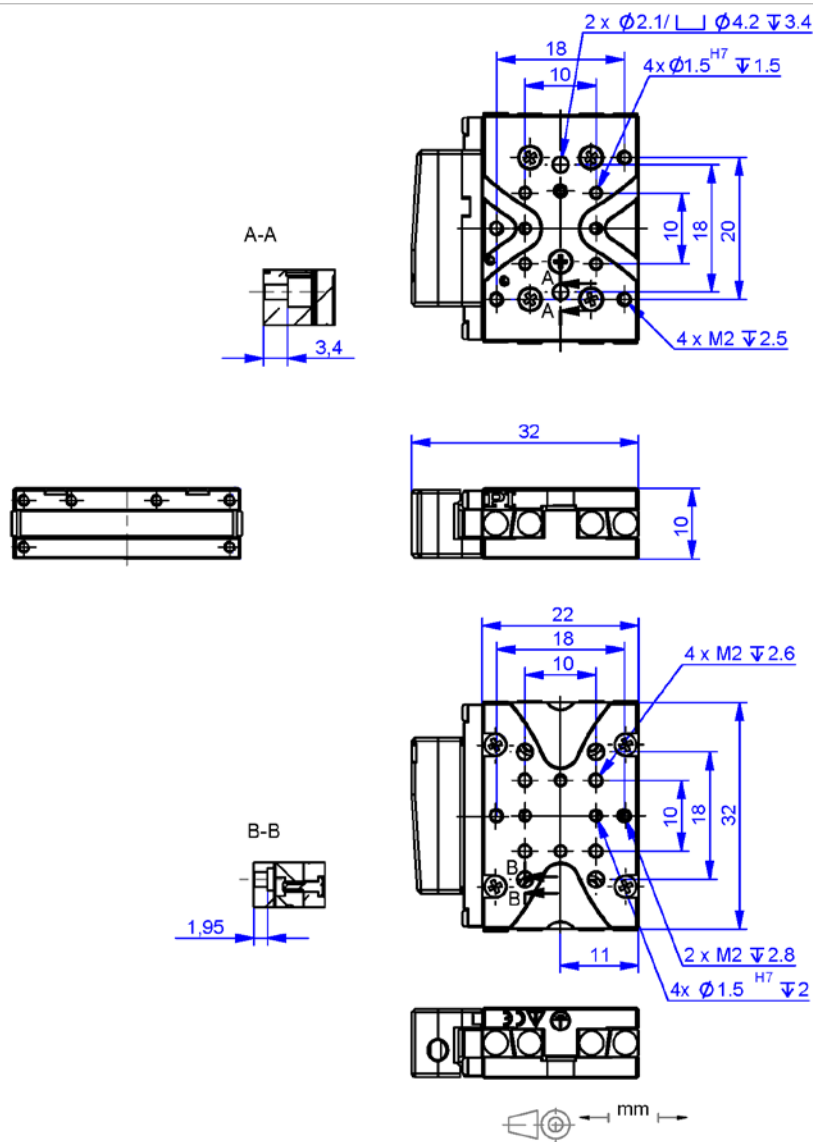

Figure 16: Q-522.14z

10.3.5 Q-522.20z

Dimensions in mm

Signs that are used to separate decimal places:

- Depth and diameter of holes: Point
- All other dimensions: Comma

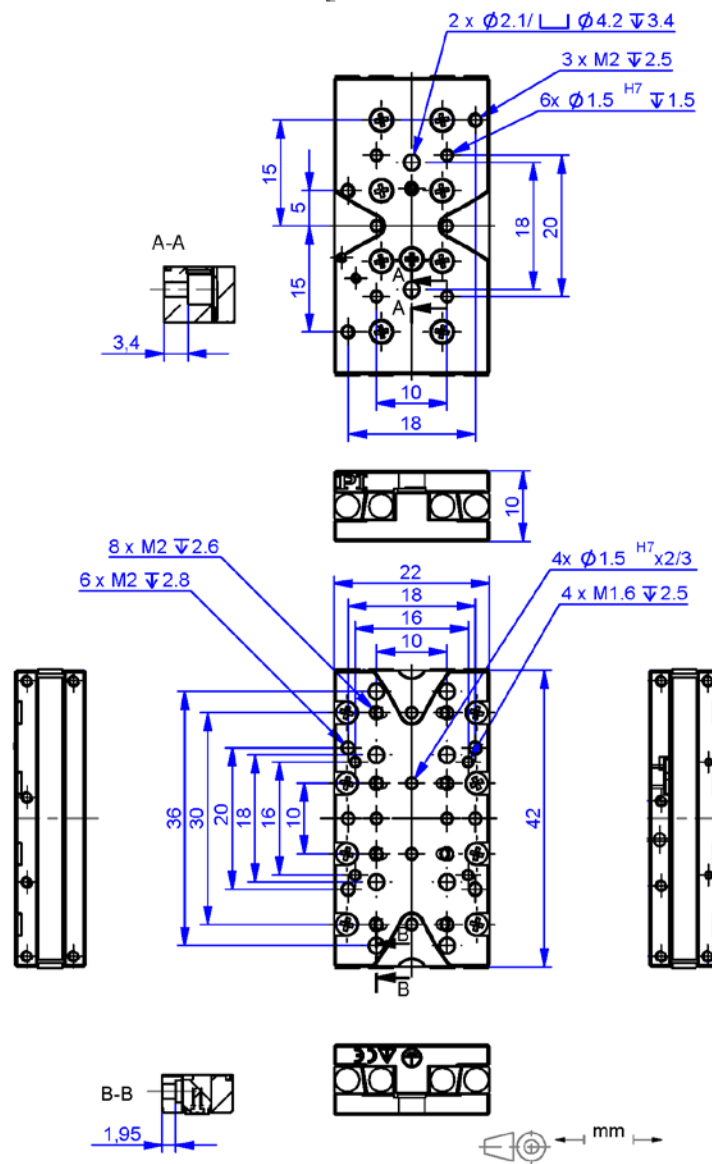

Figure 17: Q-522.20z

10.3.6 Q-522.24z

Dimensions in mm

Signs that are used to separate decimal places:

- Depth and diameter of holes: Point
- All other dimensions: Comma

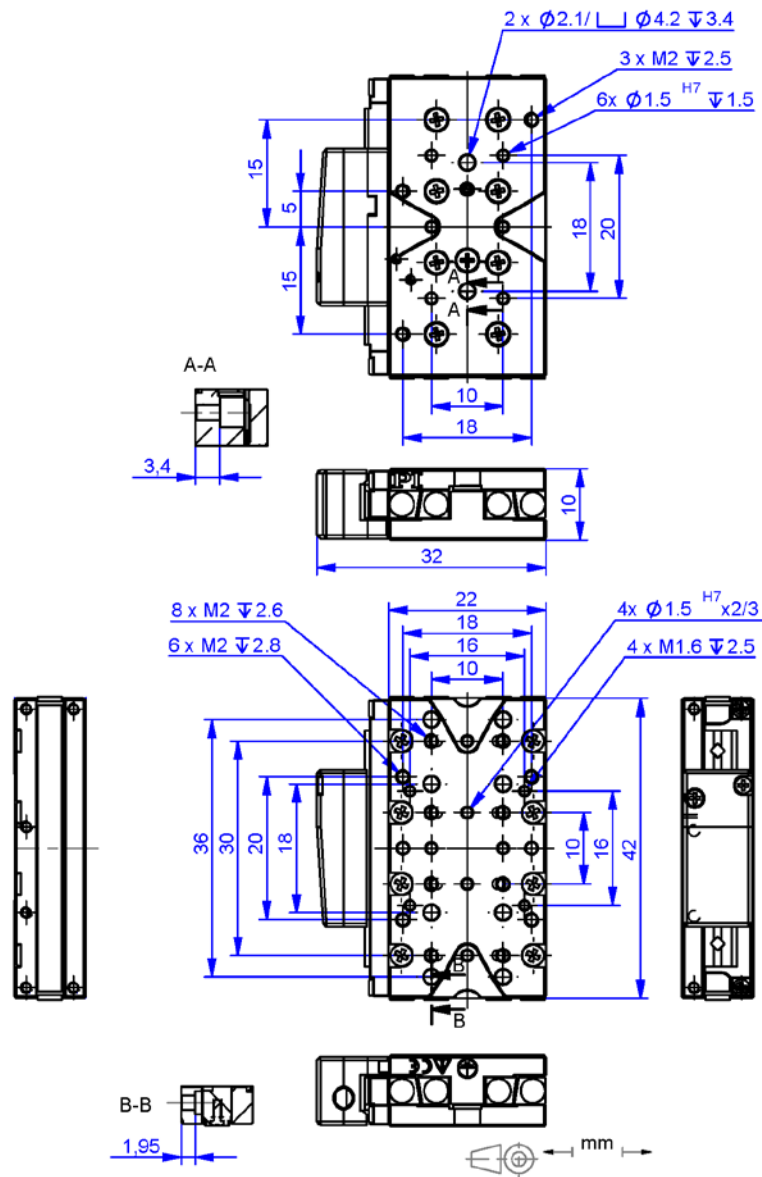

Figure 18: Q-522.24z

10.4 Pin Assignment

10.4.1 Q-522.xy0 (Vacuum-Incompatible)

Connector: Sub-D 15 (m)

The Sub-D 15 (m) connector transmits the signals of the drive and, for the models with sensor, in addition the signals of the sensor and of the ID chip.

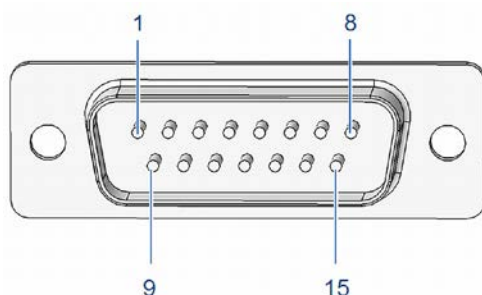

Figure 19: Sub-D 15 (m) connector

Pin	Signal ¹	Function	Direction
1	REF - ²	Reference signal differential (-)	Output
2	Motor (-)	Motor signal differential (-)	Input
3	Motor (+)	Motor signal differential (+)	Input
4	V _{DD} ²	Supply voltage (+5 V)	Input
5	-	-	-
6	ID chip data ²	ID chip data	Output
7	SIN - ²	Encoder A (-)	Output
8	COS - ²	Encoder B (-)	Output
9	Motor (-)	Motor signal differential (-)	Input
10	GND	GND	GND
11	Motor (+)	Motor signal differential (+)	Input
12	-	-	-
13	REF + ²	Reference signal differential (+)	Output
14	SIN + ²	Encoder A (+)	Output
15	COS + ²	Encoder B (+)	Output

¹ The "-" sign indicates that the corresponding pin has not been assigned.

² Only with models with sensor

The cable shield is connected to the connector shell.

10.4.2 Q-522.xyU (Vacuum-Compatible)

Connector: Sub-D 15 (f)

The Sub-D 15 (f) connector transmits the signals of the drive and, for the models with sensor, in addition the signals of the sensor and of the ID chip.

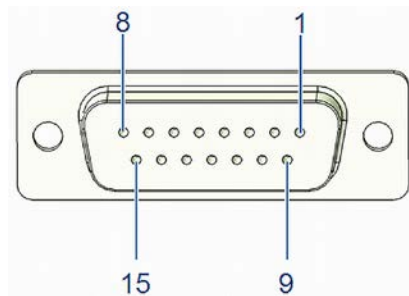

Figure 20: Sub-D 15 (f) connector

Pin	Signal ¹	Function	Direction
1	SIN - ²	Encoder A (-)	Output
2	REF + ²	Reference signal differential (+)	Output
3	COS - ²	Encoder B (-)	Output
4	V _{DD} ²	Supply voltage (+5 V)	Input
5	SH	Shield	Shield
6	-	-	-
7	-	-	-
8	Motor (+)	Motor signal differential (+)	Input
9	SIN + ²	Encoder A (+)	Output
10	REF - ²	Reference signal differential (-)	Output
11	COS + ²	Encoder B (+)	Output
12	GND	GND	GND
13	-	-	-
14	-	-	-
15	Motor (-)	Motor signal differential (-)	Input

¹ The "-" sign indicates that the corresponding pin has not been assigned.

² Only with models with sensor

The cable shield is connected to the connector shell.

11 Old Equipment Disposal

In accordance with the applicable EU law, electrical and electronic equipment may not be disposed of with unsorted municipal wastes in the member states of the EU.

When disposing of your old equipment, observe the international, national and local rules and regulations.

To meet the manufacturer's product responsibility with regard to this product, Physik Instrumente (PI) GmbH & Co. KG ensures environmentally correct disposal of old PI equipment that was first put into circulation after 13 August 2005, free of charge.

If you have old PI equipment, you can send it postage-free to the following address:

Physik Instrumente (PI) GmbH & Co. KG

Auf der Römerstr. 1

D-76228 Karlsruhe, Germany



12 EC Declaration of Conformity

For the Q-522, an EC Declaration of Conformity has been issued in accordance with the following European directives:

2006/95/EC, Low Voltage Directive

2004/108/EC, EMC Directive

2011/65/EU, RoHS Directive

The applied standards certifying the conformity are listed below.

Safety (Low Voltage Directive): EN 61010-1:2010

EMC: EN 61326-1:2013

RoHS: EN 50581:2012

