

WARNING

F-machine is designed to work on two different AC electrical systems, 240 volt / 50Hz & 110 volt / 50Hz. 240 volt is generally for Europe, Africa, Asia, Australia, New Zealand and most of South America, whereas 110 volt is for Japan, Taiwan, North America and some parts of northern South America.

Before operation, please make sure your electronics housing is set to the correct voltage for your region using the switch on the front panel of your electronics control unit (remove sticker to gain access & then replace sticker). NEVER ATTEMPT to operate the machine in the incorrect setting as this WILL cause immediate failure of the machine and could potentially cause a fire. Always use the appropriate power cable for the region you are operating in, making sure it has an earth connection.

Should you have any issues with your F-Machine or require spare parts, please contact your nearest F-Machine retailer or email us directly at sales@f-machine.com

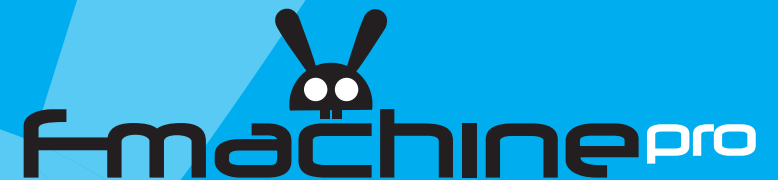

f-machinepro

WARNING: MOVING PARTS - RISK OF INJURY

Keep all objects away from moving parts during operation.
Ensure all nuts, bolts and clamps are sufficiently tight and read user manual fully prior to operation. Keep away from liquids.

Thanks for your purchase of the F-Machine Pro. 'F' stands for **Fun** (honest) and that is exactly what the F-Machine was designed for, FUN.

We have taken the utmost care in designing your F-Machine and we hope that it will service you and your friends for many years to come. Should you have any issues with your F-Machine or require spare parts, please contact your nearest F-Machine retailer or email us directly at sales@f-machine.com

F-Machine Pro Contents

In your F-Machine box you should have the following:

- 1 x main chassis including motor and fly lead
- 1 x power electronics housing with handheld speed controller
- 2 x legs with end caps
- 2 x leg T-pieces with rubber feet and plastic saddle junction
- 1 x thruster rod
- 1 x toy adaptor
- 1 x mains voltage power lead
- 1 x tool bag with necessary tools for maintenance
- 1 x small bottle of thread locking compound (use where necessary)
- 1 x manual (you're reading it)

WARNING

F-machine is designed to work on two different AC electrical systems, 240 volt / 50Hz & 110 volt / 50Hz. 240 volt is generally for Europe, Africa, Asia, Australia, New Zealand and most of South America, whereas 110 volt is for Japan, Taiwan, North America and some parts of northern South America.

Before operation, please make sure your electronics housing is set to the correct voltage for your region using the switch on the front panel of your electronics control unit (remove sticker to gain access & then replace sticker). NEVER ATTEMPT to operate the machine in the incorrect setting as this WILL cause immediate failure of the machine and could potentially cause a fire. Always use the appropriate power cable for the region you are operating in, making sure it has an earth connection.

Assembly of the F-Machine Pro

Take both legs and assemble to both T-pieces as per the diagram opposite (note the plastic saddle must be in place). Tighten as tight as possible (by hand) being careful not to break the plastic saddle.

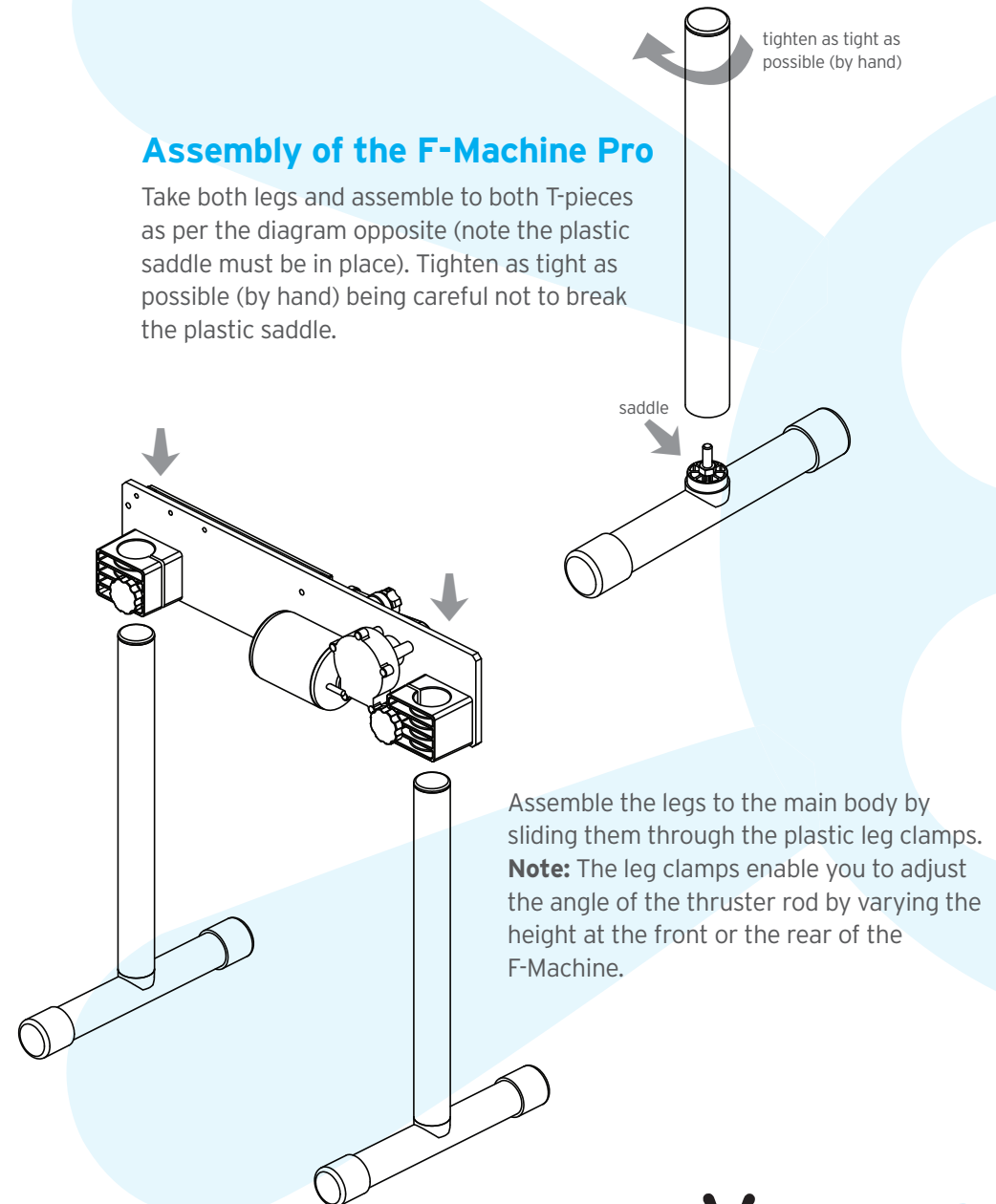

Assembly continued

Now take the toy adaptor and screw it onto the end of the thruster rod.

Slide the thruster rod into position through its dedicated clamp on the slider block.

Set the desired thrust rod length and tighten using the thumb wheel.

Note, to start with the thumb wheel & the rod/slider may be a tight fit, but once it is slid back & forth a few times it will loosen up. If it is very stiff, use some light oil such as WD40 to ease the initial connection.

Attach the motor power fly lead to the electronics output socket using the twist connector.

Attach the mains voltage adaptor lead to the power inlet socket on the electronics housing. Note: do not yet connect to a mains socket.

Operation of the F-machine Pro

WARNING: F-machine has external moving parts which could potentially cause injury if the operator is careless. Please read the following very carefully.

You are now ready to test the F-Machine. Make sure the F-Machine is turned off at both the main electronics housing and the remote control using the dedicated on/off switches.

Set the remote control to zero on the annotated speed control dial. Plug in the adaptor lead to a suitable mains voltage socket. You are now ready to start thrusting.

WARNING: Before switching on the main electronics housing using the on/off switch, ensure the following:

- the thruster rod is not likely to come into physical contact with anything it shouldn't
- the slider block is clear to oscillate on its slider rods without anything getting caught (be extra vigilant at all times as the slider block could potentially trap something valuable)
- the crank arm is free to rotate without hitting anything or catching anything

Note: remember the F-Machine is very powerful and extra care must be taken at ALL times during operation to prevent any damage to fingers. Also please be careful of long hair, loose clothing, bed linen or anything else which may get tangled in the moving parts, the F-Machine motor is very powerful and may cause injury.

Once you are happy the F-Machine is free to operate without making contact with anything it shouldn't, switch on the on/off switch on the remote control. The F-Machine is now live. Carefully turn the dial to your desired thruster speed (you can choose from any speed from zero to 240 rpm). Now watch in amazement as the thruster rams back and forth in its dominant thrusting manner.

There are many toys available for your F-Machine, most of which were originally designed for use with 'vac-u-loc' style harnesses; please check your nearest sex toy supplier for the appropriate toys for you and your friends to enjoy.

Adjusting the Thruster Depth

The F-Machine features 'fast-change', a revolutionary method of quickly changing the thruster travel via the crank arm. You can adjust the thruster's travel to any position from 1 to 6 inches. Undo the crank thumb wheel by turning approx. 180 degrees anti-clockwise (see diagram), slide to desired thrust depth & re-tighten making sure it's nice and tight & will not come loose during operation.

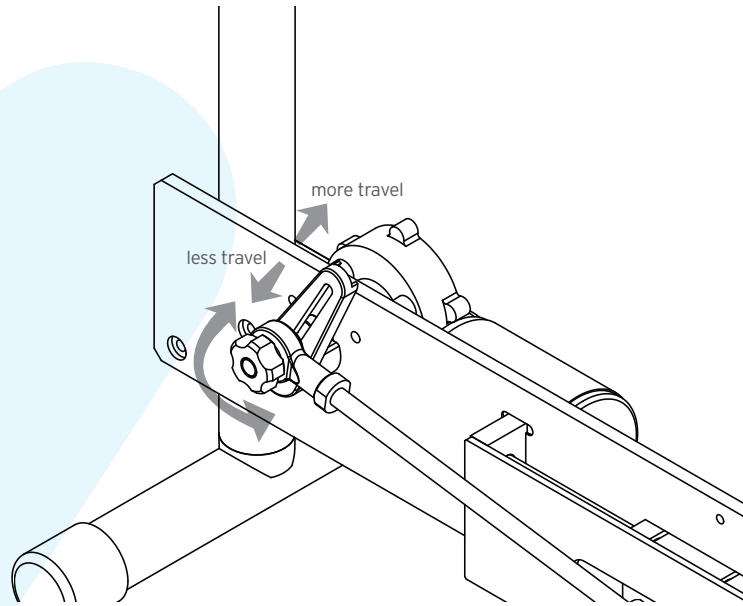

WARNING: Never attempt to adjust anything on the F-Machine whilst it is operating/moving. Always switch off the power at the hand controller and electronics control box, and disconnect from the mains power before making any adjustments.

Fault finding

F-Machine does not start

Check that nothing is jamming the slider block or crank shaft and that the crank and slider are free to move (power off).

Check for damage to the power lead OR to the remote control lead (replace where necessary). Note: the remote lead should only be replaced by a qualified electrician.

Check both switches are set to 'on' and that the speed control dial is not set to zero.

Check that the speed control knob on the remote is tight on its spigot and that the potentiometer is turning correctly.

Check that the motor retaining bolts are tight.

Check that both the motor power lead and the 240v/110v lead are firmly in their sockets in the electronics housing.

Check that the mains socket has power & that the power is switched on.

Check the fuses (replace where necessary).

If none of the above remedy the issue, please consult a qualified electrician or return the F-Machine to your F-Machine supplier for repair.

F-Machine works intermittently

Check that nothing is jamming the slider block or crank shaft and that the crank and slider are free to move (power off).

Check for damage to the power lead OR to the remote control lead (replace where necessary). Note: the remote lead should only be replaced by a qualified electrician.

Check the power lead is firmly in its socket in the electronics housing and that it is firmly plugged into the electrical wall socket.

Check that the motor fly lead is correctly connected to the outlet socket on the electronics housing.

If all above are correct, stop using the F-Machine and consult your supplier or a qualified electrician.

F-Machine makes a 'knocking' or other strange noise

Inevitably the F-Machine will make some noise during operation, however if that noise seems to be excessive compared to normal use then carry out the following (power off):

Check the crank arm is tight on the motor shaft.

Check the con-rod is tight both on the crank arm and on the slider block. Also check for excessive wear or play in these joints. Replace worn components as necessary.

Check the slider rods and blocks are held tight and are firmly fixed to the main body plate.

Check the slider block plastic slider bearings for play and replace if excessively worn.

Check the thruster rod is tight.

Rock the crank arm back and forth with the con rod disconnected and listen for knocking noises from the gearbox. If the noise comes from the gearbox then carefully remove the gearbox cover and re-grease the gearbox (only to be carried out by mechanically competent persons).

F-Machine makes a strange whirring noise

Check motor retaining bolts are tight.

Check gearbox for grease, re-grease where necessary (only to be carried out by mechanically competent persons).

General Safety Notes (Important)

Delivery

Immediately check the packaging and F-Machine for any damage which may have been caused in transit. Do not use a damaged F-Machine, consult your supplier.

Please dispose of the packing material sensibly & responsibly, recycling where appropriate.

The corrugated cardboard is constructed from recycled paper.

Electrical connection & other safety notes

Please READ the operating instructions before using the F-Machine for the first time.

Please observe the instructions contained in the Operating Instructions.

Please consider all warnings.

MAKE SURE that all power connections (extension cables and the connections between the F-Machine components) have been made properly and in accordance with the manufacturer's instructions. Before making or changing the connections, power off the F-Machine and unplug the mains connection plug.

If you have any doubts regarding the installation, operation or safety of the F-Machine, please REFER to the vendor.

DO NOT COVER the ventilation openings of the F-Machine .

Overheating causes damage and shortens the service life of the F-Machine.

Your F-Machine may be damaged if you place it under direct sunshine or close to a heater. Please abstain from using the product in very

hot or humid locations or in places where the temperature is likely to decrease below 5°C (41°F). DO NOT PLACE on or near the F-Machine any hot objects or items with open flame such as candles or any night lamps. The high temperature can melt plastic parts and cause a fire.

Never operate electrical F-Machines close to water. For example, operating F-Machines near a bathtub, washbasin, wet basement or swimming pool can cause fire or electric shock.

Do not allow your F-Machine to get wet. Never pour any liquids onto the F-Machine. Do not operate your F-Machine if any solid or liquid substance enters into it. This can cause electric shock and your F-Machine may be damaged. Have it checked immediately by qualified personnel.

Always place the F-Machine on a firm, flat and horizontal surface during operation. Never place or operate the F-Machine on soft furnishings.

Never operate the F-Machine on a raised surface (such as a table), where there is insufficient flat surface available or where it could be knocked over and cause injury or damage to property.

Never leave an F-Machine plugged in unattended. Keep out of the reach of minors and away from animals.

Never deliberately jam the crank arm or slider mechanism.

Your F-Machine is a grounded product (Class I) and it must certainly be connected to a grounded socket.

The socket into which you plug in the AC power cable or the adaptor must be within easy reach.

Turn off your F-Machine with the ON/OFF switches and then unplug it in order to disconnect it from mains. Do not use defective power sockets. Make sure that the plug is firmly inserted into the power socket. If the plug remains loose, then it can cause fire due to arcing. Refer to an electrician to have your power socket replaced.

Make sure that the power cable is not stepped on and that there is no bending at the plug sections, plug heads and F-Machine output point.

Use only the add-ons/accessories specified by the manufacturer.

Use only together with the bases, tripods, brackets or stands specified by the manufacturer or sold along with the product.

Unplug the power cable during thunderstorms or when you will not use your F-Machine for a long period of time.

Consult authorised service personnel for service requirements. Never attempt to repair the F-Machine yourself. Opening the electronics control housing can expose you to dangerous voltages or other hazardous situations. Service is required in situations such as damage to the power cable of the F-Machine or its plug, water spills or substances falling into the F-Machine, if the F-Machine is subjected to rain or moisture, it does not operate normally or it is dropped.

Wipe the F-Machine clean with a soft and dry cloth. Wipe dust gently with a soft cloth. Stubborn stains can be cleaned with a cloth slightly moistened with soap and lukewarm water. Never use solvents such as thinners or gasoline for cleaning. Unplug the AC power cable from the socket when cleaning the F-Machine. Otherwise, there is the risk of electric shock.

Do not short circuit, dismantle or modify your F-Machine.

Dispose of the F-Machine in accordance with the local laws and regulations in order to protect our environment.

Do not dispose of your F-Machine with regular household waste. Observe local laws and regulations for disposal.